

Flow rate

- From 0.009 ml/h to 2.14 l/h

Pressure

- Up to 50 bar

Liquid ends

- PVC, stainless steel
- Design for viscous products

DSD Technology®,
Reinventing
metering pumps

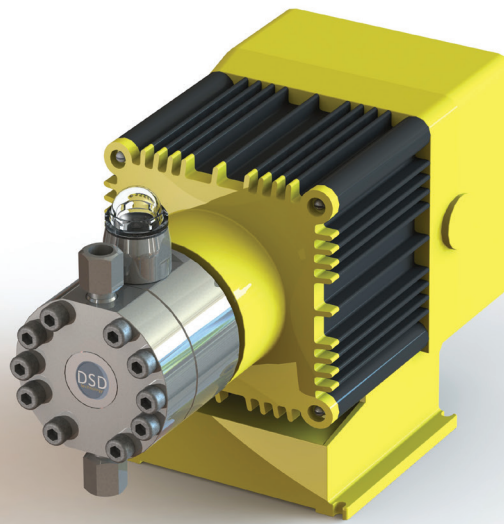

Electromagnetic dosing pump LMI C

Rigid diaphragm liquid end | DSD Technology®

- The performance of a plunger metering pump, the safety of a hydraulic diaphragm metering pump
- Optimised complete pump life cycle cost
- DSD Technology®: Milton Roy technology protected by 2 patents

TYPICAL APPLICATIONS

- **Boiler water treatment:** injection of phosphate, corrosion inhibitor
- **Water treatment:** proportional injection of chemicals
- **Laboratory / Pilot plant:** injections requiring micro flow rates, test procedures
- **Food-processing / wine-making industries:** injection of food additive, alcohol
- **Paper industry:** injection of bleaching agents

BENEFITS

- **Injection at very low flow rates:** from 0.009 ml/h
- **Wide injection range:** the flow rate is adjustable with a ratio from 1 to 200 for the C1 series, from 1 to 1,000 for the C7 series and from 1 to 58,824 for the C9 series
- **Max. rated pressure:** 50 bar for stainless steel, 25 bar for PVC
- **Environmental protection:** injection of highly concentrated products (REACH)
- **Dosing of high viscosity products:** 1,350 cP (XV stainless steel liquid end)
- **Easy to use:** 6 mWC suction head
- **Pressure adjustable on 6 levels (C7 and C9 series):** the pump's maximum pressure level can be adjusted to reduce pulsing in the discharge line, attenuate pump noise and optimise the service life of the mechanical elements
- **Safety:** unbreakable rigid diaphragm
- **Reduced operating and maintenance costs:** long service life diaphragm, few liquid end components
- **4-function compensation system:** continuous bleed, readmission, visual oil level indicator, oil tank
- **Compact footprint:** 11.5 cm floor-mounted, 12 kg
- **2-year warranty**

DSD : Dynamic Stiffness Diaphragm

Innovative Sustainability Together

 **MILTON ROY**
EUROPE

Technical features

Main characteristics

- Accuracy: $\pm 2\%$ over a range of 10 to 100% of the nominal flow rate
- Linear stroke frequency adjustment: while running or stopped.
C1 series: from 1 to 100 strokes/min, C7 series: from 5 to 100 strokes/min, C9 series: from 1 strokes/h to 100 strokes/min
- Linear stroke length adjustment: from 10% to 100% recommended
- Thrust: 400 N
- 100% strokes: 1.61 mm / 2.83 mm
- Temperatures of pumped fluids: stainless steel liquid ends: $-5\text{ }^{\circ}\text{C}$ to $+50\text{ }^{\circ}\text{C}$ as standard / PVC liquid end: $+10\text{ }^{\circ}\text{C}$ to $+50\text{ }^{\circ}\text{C}$
- Maximum ambient temperature: $+50\text{ }^{\circ}\text{C}$
- Protection: IP65
- Maximum viscosity: standard liquid ends: 45 cP / XV liquid end for viscous products: 1,350 cP
- Suction lift: 6 mWC primed
- Minimum discharge pressure: 2 bar
- Valves: double valve and double ball valve as standard

Available liquid ends (parts in contact with the liquid pumped)

	PVC LIQUID END	S.S. LIQUID ENDS
Liquid end body	PVC	316L
Check valve assembly	PVC	316L
Seats	Hastelloy C	316L
Balls	Hastelloy C	Hastelloy C
Diaphragm	PEEK	PEEK
Seals	PTFE	NA

Electrical characteristics

- Supply : 230 V and 115 V
- Frequency: 50 Hz to 60 Hz
- Automatic compensation of variations in the mains voltage and overvoltage protection

Performances

PLUNGER DIAMETER	PLUNGER STROKE LENGTH	FLOW RATE		MAX. PRESSURE	MAX. SUCTION PRESSURE	MAX. FREQUENCY	MIN. STROKE LENGTH	MAX. VISCOSITY (*)		MAX. POWER	CONNECTIONS
		10 bar	P max					Standard	XV Liquid End		
mm	mm	l/h	l/h	bar	bar	spm	%	mPA.s	mPA.s	watt	
XR47 and XV47 - S.S. liquid ends											
10	1.61	0.64	0.54	50	48	100	10	45	1350	420	1/4" NPT female
12		0.92	0.72	40	38				900		
14		1.22	1.04	25	23				630		
10	2.83	1.13	0.95	50	48	100	10	45	770	420	1/4" NPT female
12		1.61	1.27	40	38				500		
14		2.14	1.82	25	23				360		

(*) At the maximum viscosity, flow rate has to be derated by 10% for XV liquid end (viscous products)
1 mPa.s = 1 cP

PLUNGER DIAMETER	PLUNGER STROKE LENGTH	FLOW RATE		MAX. PRESSURE	MAX. SUCTION PRESSURE	MAX. FREQUENCY	MIN. STROKE LENGTH	MAX. VISCOSITY	MAX. POWER	CONNECTIONS
		10 bar	P max							
mm	mm	l/h	l/h	bar	bar	spm	%	mPA.s	watt	
CR47 - PVC liquid end										
10	1.61	0.64	0.61	25	23	100	10	45	420	1/4" Gas female
12		0.92	0.82							
14		1.22	1.04							
10	2.83	1.13	1.07	25	23	100	10	45	420	1/4" Gas female
12		1.61	1.44							
14		2.14	1.82							

Control modes (depending on the model)

- Manual control by linear adjustment of the stroke frequency and stroke length
- External pulse control by volt-free contact. The stroke frequency is then set by external pulses, for example from a water meter
- Direct external proportional control by 4-20 mA analogue signal (direct or indirect response). The amount of product injected is proportional to the level of the input signal in mA
- Remote on/off
- Possibility of connecting a level switch (optional accessory) to monitor the product transfer operation

Advanced configurations of the C9 series

- Integrated division / multiplication of control pulses (1 to 999)
- Batch accumulation dosing: if the «pulse multiplication» function is selected, batch dosing is accumulated. A batch is dosed each time the pump receives an external pulse. If the pump receives new pulses before a batch is complete, this function makes it possible to take these new pulses into account and deliver the corresponding amount of product. If this function is inactive, the new pulses are ignored
- Pulse width: programming of the pulse width (from 4 ms to 60 ms, in 4 ms increments) so that it is exactly right for the process
- Locking: protection of the pump's settings, avoiding erroneous operation

The C9 series can supply the following information as an output via a 8-pin connector:

- Pulses: the pump will supply a 100 ms pulse each stroke
- Remote alarm transfer
- Power supply (15 VDC) for connection of accessories

Coding | Standard & options

Standard

Electromagnetic dosing pump LMI C with DSD® Technology liquid end

C	LMI C with DSD® Technology liquid end - Series from 0.009 ml/h to 2.14 l/h						
	Control						
	1	Stroke frequency and stroke length manually adjustable					
	7	C1 features + external control by voltage-free contact. Low level function (option)					
	9	Programmable, microprocessor based pump. C7 features + proportional external control by 4-20 mA analog signal + integrated pulse divide/multiply functions					
	Plunger stroke - Please refer to the performance tables to select the stroke according the needed flow rate						
	A	1.61 mm					
	B	2.83 mm					
	Supply						
	1	115 V, US plug					
	3	230 V, CEE plug					
	5	230 V, UK plug					
	-	Liquid end separation					
		DSD liquid end type					
	CR	PVC liquid end					Max. pressure = 25 bar
	XR	316L S.S. liquid end					Max. pressure = 50 bar
	XV	316L S.S. liquid end for viscous products (special check valves)					Max. pressure = 50 bar
	Plunger diameter						
	10	Plunger Ø 10 mm					
	12	Plunger Ø 12 mm					
	14	Plunger Ø 14 mm					
	Connections						
		Threaded connections					
	P	Code CR (plastic): 1/4" Gas female Codes XR and XV (S.S.): 1/4" NPT female					
C	9	A	3	-	XR	10	P

Dimensions and packing

Dimensions (in mm)

LMI C DSD STAINLESS STEEL LIQUID ENDS: XR47 AND XV47

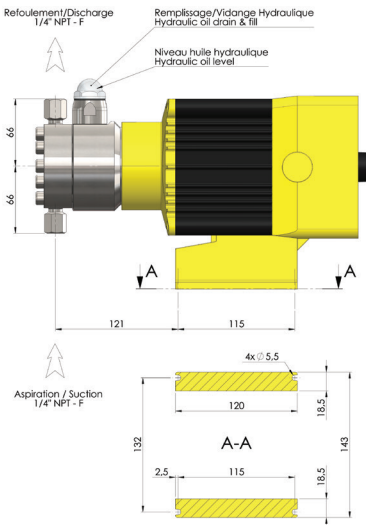

LMI C DSD PLASTIC LIQUID ENDS: CR47

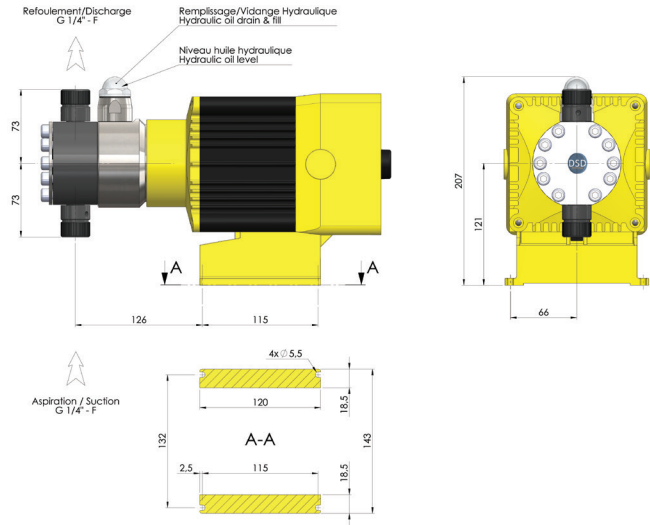

NET WEIGHT (*) kg	GROSS WEIGHT (*) kg	PACKING (mm) (L x W x H)
12	12.3	380 x 235 x 290

(*) Approximately. The overall dimensions are provided as an indication only.

Accessories

The LMI C-series pumps with DSD liquid end technology are delivered with the control cables required for their numerous operating configurations.



Milton Roy Europe proposes a wide range of accessories to complete the installation of your pump.



Spare parts

Milton Roy Europe advises you on the essential wear parts to be kept on hand in order to optimize the performance of your equipment.



Dosing stations

A turnkey solution

Compact and fully-featured, DOSAPACK® stations are ideal for the preparation, storage and injection of reagent solutions.



MILTON ROY EUROPE | INNOVATIVE SUSTAINABILITY TOGETHER

An outstanding team of engineers and technicians:

- Guides you in selecting the turnkey solution that best suits your needs
- Provides you personalized project management
- Advises you on the optimum installation of your equipment
- Consults with your specialists to develop specific products and anticipate your future requirements

A network of over 100 distributors and sales and service offices.
To find your local representative, visit our website:
www.miltonroy-europe.com

LMI DSD Technology liquid end - Ref. 160 5022 201N - 05/13
All rights reserved for modification without prior notice.
Picture for illustration purposes only - Printed in France.

Conception | mad'line | 02 35 50 04 04 | www.madline.fr | madline@madline.fr

