

General Purpose Clutches

FSR

Overrunning, Indexing, Backstopping Sleeve Bearing Supported, Sprag Clutches

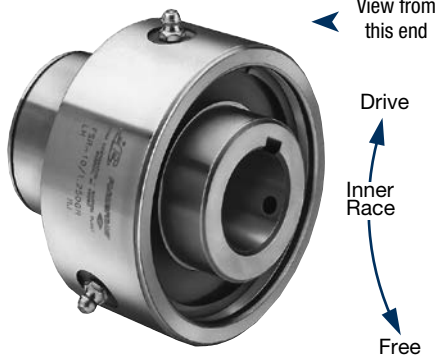

Right Hand rotation shown.
(Left Hand opposite.)

Specify direction of rotation when ordering.

There are eight sleeve-bearing clutch models suitable for general purpose applications—overrunning, indexing and backstopping. To provide maximum life and resistance to wear, all FSR model clutches incorporate Formchrome® sprags; models FSR-5 thru FSR-16 have the Formsprag “Free-action” sprag retainer. A keyseat and snap-ring groove

are provided to secure attached parts to the hub, which is ground as a mounting surface. Oil lubricated models have a Buna-N oil seal at each end of the clutch which provides positive lubricant sealing. They can be removed for free lubricant flow if clutch is operated in an oil bath.

The shaft must extend through the full length of the clutch and must be held to recommended limits because the sleeve-bearing in the outer race rides on the shaft.

The keyseat in the shaft must not extend into the sleeve-bearing area of the clutch. Refer to Bore Sizes/Shaft Tolerances chart on page 128.

For vertical mounting, contact Application Engineering.

FSR-3 through 16 clutches are shipped from the factory packed with Fiske Brothers Lubriplate Low-Temp grease.*

FSR-3 are grease lubricated for life.

Oil lubricated clutches are shipped without lubrication and require filling before use.

For further information see *Installation and Maintenance Bulletin No. 2217, P-222-8.*

Typical Mounting Arrangement

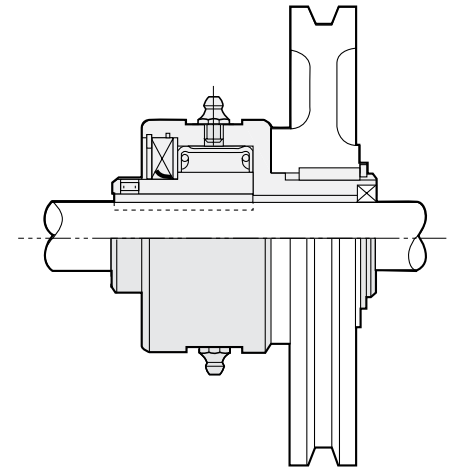

The Model FSR-3 is secured to the shaft by a .187 roll pin (furnished). Models FSR-5 and up are secured to the shaft by two set screws also furnished.

Specifications

Size	Torque Capacity lb.ft. (Nm)	Overrunning Speed Max. RPM		Resistance after run-in lb.ft. (Nm)	Keyseat in Hub (W) (output) in. (mm)	Lubrication (Grease) Required* oz (ml)	Shipping Weight lb. (kg)
		Inner Race	Outer Race				
3	40 (55)	1,950	900	.20 (.27)	1/8 x 1/16 (3.18 x 1.58)	Grease	1 (0.5)
5	110 (150)	1,950	900	.50 (.68)	3/16 x 3/32 (4.76 x 2.38)	.25 (7.4)	2 (0.9)
6	300 (408)	1,950	750	1.68 (2.28)	3/16 x 3/32 (4.76 x 2.38)	.375 (11.1)	3 (1.4)
8	450 (612)	1,650	600	2.80 (3.80)	1/4 x 1/8 (6.35 x 3.17)	.5 (14.8)	5 (2.3)
10	675 (918)	1,250	350	3.50 (4.75)	5/16 x 5/32 (7.93 x 3.96)	.5 (14.8)	6 (2.7)
12	1,350 (1836)	1,150	350	5.84 (7.90)	3/8 x 3/16 (9.52 x 4.76)	.75 (22.2)	9 (4.0)
14	1,600 (2176)	950	250	6.87 (9.30)	7/16 x 7/32 (11.11 x 5.54)	1 (29.6)	15 (6.8)
16	1,800 (2448)	950	250	6.87 (9.30)	1/2 x 1/4 (12.70 x 6.35)	1 (29.6)	15 (6.8)

Notes:

Check key and shaft stress before making final clutch selection since this may determine the maximum allowable drive torque capacity.

Specify direction of rotation when ordering.

* Oil lubricated designs are also available. Oil lubricated clutches are shipped without lubrication and require filling before use.

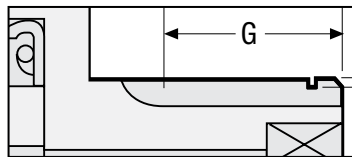
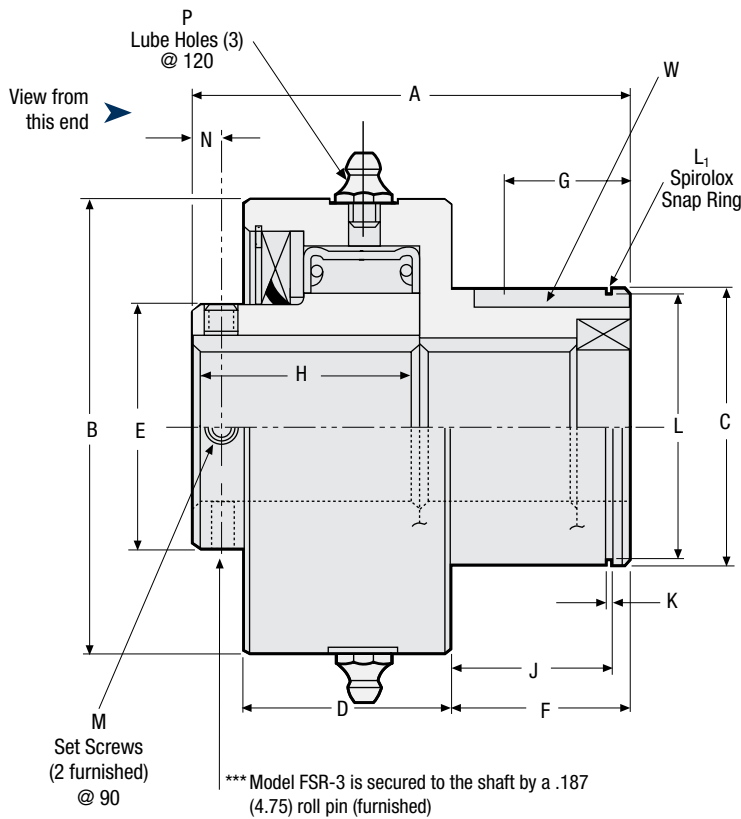

Optional Woodruff key seat in outer race is available

Bore sizes and keyseats[‡] inches (mm) (Metric bore also available)

Size	Bore Size	Keyseat	Bore Range	
			Min.	Max.
3	.375/.500 (9.52/12.70)	***	.375 (9.52)	.500 (12.70)
	.500 (12.70)	1/8 x 1/16 (3.18 x 1.59)	.500 (12.70)	.687 (17.45)
5	.625 (15.88)	3/16 x 3/32 (4.76 x 2.38)		
	.750 (19.05)	3/16 x 3/32 (4.75 x 2.38)	.750 (19.05)	.875 (22.22)
6	20mm	6 x 2.8mm [†]		
	.875 (22.22)	1/4 x 1/8 (6.35 x 3.18)		
8	25mm	8 x 3.8mm [†]	.688 (17.46)	1.125 (28.57)
	1.000 (25.40)	1/4 x 1/8 (6.35 x 3.18)		
10	1.125 (28.58)	5/16 x 5/32** (7.93 x 3.96)		
	30mm	8 x 3.8mm [†]	.875 (22.22)	1.375 (34.92)
12	1.250 (31.75)	5/16 x 5/32 (7.93 x 3.96)		
	1.375 (34.93)	5/16 x 5/32 (7.93 x 3.96)	1.125 (28.57)	1.625 (41.27)
14	1.500 (38.10)	3/8 x 3/16 (9.52 x 4.76)		
	40mm	12 x 3.3mm [†]		
16	1.625 (41.27)	7/16 x 7/32 (11.11 x 5.54)	1.375 (34.92)	1.875 (47.62)
	1.750 (44.45)	7/16 x 7/32 (11.11 x 5.54)		
16	45mm	12 x 3.3mm [†]		
	1.875 (47.62)	1/2 x 1/4 (12.70 x 6.35)	1.500 (38.10)	2.187 (55.55)
16	50mm	14 x 3.8mm [†]		
	2.000 (50.80)	1/2 x 1/4 (12.70 x 6.35)		

** 250 x .13 also available

‡ For Bore Sizes/Shaft Tolerances, see page 128.

Dimensions inches (mm)

Size	A	B	C	D	E	F	G	H	J	K	L	L1*	M	N	P
3	1.88 (47.62)	1.63 (41.27)	.875/.874 (22.23/22.20)	.69 (17.46)	.70 (17.78)	.81 (20.64)	.500 (12.70)	.94 (33.32)	.715/.720 (18.16/18.29)	.036/.056 (.91/1.42)	.841/.835 (21.36/21.21)	RS 87	—	.22 (5.54)	—
5	2.75 (69.85)	2.00 (50.80)	1.250/1.249 (31.75/31.72)	1.25 (31.75)	1.00 (25.40)	1.00 (25.40)	.562 (14.27)	1.63 (41.27)	.900/.905 (22.86/22.99)	.048/.068 (1.22/1.73)	1.206/1.198 (30.63/30.43)	RS 125	#8-36	.25 (6.35)	#10-32
6	3.19 (80.95)	2.88 (73.00)	1.375/1.374 (34.93/34.90)	1.56 (39.67)	1.38 (34.92)	1.31 (33.32)	.937 (23.80)	1.69 (42.85)	1.215/1.220 (30.86/30.99)	.048/.068 (1.22/1.73)	1.327/1.319 (33.70/33.50)	RS 137	#10-32	.18 (4.75)	.250-28
8	3.56 (90.50)	3.25 (82.55)	1.750/1.749 (44.45/44.42)	1.75 (44.45)	1.62 (41.27)	1.44 (36.50)	1.00 (25.40)	1.88 (47.62)	1.315/1.320 (33.40/33.53)	.056/.076 (1.42/1.93)	1.696/1.686 (43.08/42.82)	RS 175	.250-28	.25 (6.35)	.250-28
10	3.50 (88.90)	3.75 (95.25)	2.250/2.249 (57.15/57.12)	1.75 (44.45)	2.03 (51.59)	1.44 (36.50)	.94 (23.80)	1.81 (46.02)	1.340/1.345 (34.04/34.16)	.056/.076 (1.42/1.93)	2.182/2.170 (55.42/55.12)	RS 225	.250-28	.25 (6.35)	.250-28
12	3.88 (98.42)	4.44 (112.70)	2.500/2.499 (63.50/63.47)	1.94 (49.20)	2.38 (60.32)	1.44 (36.50)	1.19 (30.22)	2.13 (53.97)	1.311/1.321 (33.30/33.55)	.120/.130 (3.05/3.30)	2.391/2.379 (60.73/60.43)	RST-250	.312-24	.31 (7.92)	.250-28
14	4.38 (111.12)	5.50 (139.70)	2.875/2.874 (73.03/73.00)	2.19 (55.56)	3.00 (76.20)	1.75 (44.45)	1.34 (34.04)	2.25 (57.15)	1.625/1.630 (41.27/41.40)	.056/.076 (1.42/1.93)	2.787/2.775 (70.79/70.48)	RS 287	.312-24	.31 (7.92)	.250-28
16	4.38 (111.12)	5.50 (139.70)	3.250/3.249 (82.55/82.52)	2.19 (55.56)	3.00 (76.20)	1.75 (44.45)	1.44 (36.58)	2.25 (57.15)	1.650/1.655 (41.91/42.04)	.068/.088 (1.72/2.23)	3.156/3.144 (80.16/79.86)	RS 325	.312-24	.31 (7.92)	.250-28

* Spirolox snap ring not included.

† Contact Formsprag for keyseat information.