

AUTO-HINGE Flag Type

Wooden door, Aluminum door
Light steel door

300 series
1000 series
2000 series

Wooden door, Aluminum door
Light steel door, Steel door

100 series

Wooden door, Aluminum door
Steel door

200 series

Aluminum door, Stainless door
Steel door

700 series

Wooden door, Aluminum door
Light steel door, Steel door

PC series

Glass door

NK series



311S



1221



112



244-T



113-PC



733



NK153



AUTO-HINGE Flag Type

Door closer + hinge, All-In-One. Quiet and smooth operation is achieved by the hydraulic pressure mechanism and advanced spring technology. Simple design with fully adjustable self-closing feature offers aesthetic appearance and refined functionality to the door.

Butterfly Type (300 Series) P.3

- Small and slim, ideal for lightweight doors (indoor use).
- The butterfly design makes installation highly efficient.
- Non handed - Can be used for both right and left hand opening doors.



Flag Type (100 / 1000 / 2000 Series) P.3

- Designed with cutting edge technology from Nitto Kohki. Easy to install on all kinds of swing doors (regular rectangle doors, arch doors, etc).
- Variety of models available for different size and type of doors (wooden, aluminum, lightweight steel, steel and glass doors).



INDEX

Flag type series (Table of models with specifications)

Indoor use

Model number	Type of door	Door size applicable (mm)			Door weight (kg) (Max)	Closing force (N·m)	Stop mechanics	Stop angle	Max. Opening angle	Color	Page											
		Right hand opening	Left hand opening	W (Max)								H (Max)	D (Min)									
300 Series	Wooden door Aluminum door	311S (Available for both right and left)		800	2000	30	5.0	○	85°~180° (Free stop)	180° Left or right one side opening	Silver Bronze Ivory Gold	4										
		Empty hinge 310 (Available for both right and left)																				
1000 Series	Wooden door Aluminum door Light steel door	1111R	1111L	850	2000	30	7.9	○	85°	180° Left or right one side opening	Silver	5										
		1111SR	1111SL																			
		1121R	1121L																			
		1121SR	1121SL																			
		1111FR	1111FL								○	85°~180° (Free stop)										
		1121FR	1121FL																			
		1211R	1211L										○	85°								
		1211SR	1211SL																			
		1221R	1221L								○	85°										
		1221SR	1221SL																			
		1211FR	1211FL										○	85°~180° (Free stop)								
		1221FR	1221FL																			
		Empty hinge	1110R								1110L	-			-	-	-	-	-	-	Silver	5
			1120R								1120L											
1210R	1210L																					
1220R	1220L																					
2000 Series	Wooden door Aluminum door Light steel door	2211R	2211L	800	2000	30	30	-	-	-	180° Left or right one side opening	Silver	7									
		2211WR	2211WL																			
		2210R	2210L																			
		2210WR	2210WL																			
	100 Series	Wooden door Light steel door (122T for steel frame)	112R	112L	900	2100	40	10.0	○	85° and 150°	180° Left or right one side opening	Silver or Bronze	8									
			112SR	112SL																		
			122R-T	122L-T																		
			122SR-T	122SL-T																		
			113R	113L										60	15.0	○	85° and 150°					
			113SR	113SL																		
		Wooden door Aluminum door	113R TRISET	113L TRISET	1000	2200	80	20.0	○	85° and 150°												
			113SR TRISET	113SL TRISET																		
		100 Series	Wooden door Light steel door Steel frame	122R-AT	122L-AT	900	2100	40	10.0	○	85° and 150°	180° Left or right one side opening	Silver	12								
				122SR-AT	122SL-AT																	
Aluminum door Light steel door Partition door	132R		132L	60	15.0										○	85° and 150°						
	132SR		132SL																			
Steel door	143R-T		143L-T	-	-										-	-	-	-	-	-	-	
	143SR-T		143SL-T																			
	143R-AT		143L-AT																			
	143SR-AT		143SL-AT																			
100 Series	Wooden door Light steel door (120T for steel frame)	110R	110L	900	2100	40	-	-	-	-	-	-										
		120R-T	120L-T																			
		120R-AT	120L-AT																			
	Aluminum door Light steel door Partition door	130R	130L										60	-	-	-	-	-	-	-	-	
		140R-T	140L-T																			
		140R-AT	140L-AT																			
2000 Series	Heavy wooden door Aluminum door Steel door	234R	234L	1200	2100	40	120	22.6	○	85° and 150°	180° Left or right one side opening	Silver	16									
		234SR	234SL																			
		244R-T	244L-T																			
	Steel door	244SR-T	244SL-T											-	-	-	-	-	-	-	-	-
		230R	230L																			
		240R-T	240L-T																			



Drip-proof Type
700 series P.18

- Made in highly durable stainless steel with special sealing mechanism.
- Commercial grade, widely applicable for various locations including bathrooms, seashores etc.



Drip-proof Type
PC series P.20

- Drip-proof design, suitable for outdoor use or moist area.
- Adopts an actuator with unique temperature sensor, ensuring consistent closing speed all year round.



For glass doors
NK series P.26

- Suitable for glass doors 8 to 12mm thick



Outdoor use

Model number			Type of door	Door size applicable (mm)			Door weight (kg) (Max)	Closing force (N·m)	Stop mechanics	Stop angle	Max. Opening angle	Color	Page							
Right hand opening	Left hand opening	W (Max)		H (Max)	D (Min)															
700 Series	733R	733L	Aluminum door Stainless door Steel door	900	2100	40	120	15.0	-	-	180° Left or right one side opening	Shine gray	19							
	733SR	733SL							○	85° and 150°										
	Empty hinge 730R	730L							-	-										
100PC Series	113R-PC	113L-PC	Wooden door Aluminum door Light steel door	900	2100	30	40	15.0	-	-	180° Left or right one side opening	Silver	21							
	113SR-PC	113SL-PC							○	85° and 150°										
	133R-PC	133L-PC	Aluminum door Light steel door						-	-										
	133SR-PC	133SL-PC							○	85° and 150°										
	143R-T-PC	143L-T-PC	Steel door						-	-										
	143SR-T-PC	143SL-T-PC							○	85° and 150°										
	Empty hinge	110R-PC	110L-PC						Wooden door Light steel door	-				-	40	-	-	-	-	21
130R-PC		130L-PC	Aluminum door Light steel door	-	-	40	-	-	-	-	22									
140R-T-PC		140L-T-PC	Steel door	-	-	60	-	-	-	-	23									
200PC Series	234R-PC	234L-PC	Heavy wooden door Aluminum door Steel door	1200	2100	40	120	22.6	-	-	180° Left or right one side opening	Silver	24							
	234SR-PC	234SL-PC							○	85° and 150°										
	244R-T-PC	244L-T-PC	Steel door						-	-										
	244SR-T-PC	244SL-T-PC							○	85° and 150°										
	Empty hinge	230R-PC	230L-PC						Heavy wooden door Aluminum door Steel door	-				-	-	-	-	-	-	24
		240R-T-PC	240L-T-PC						Steel door	-				-	-	-	-	-	-	25

Glass door hinge

Indoor use

NK Series	NK153R-SC	NK153L-SC	Glass door	900	2100	8 10 12	60	15.0	-	-	180° Left or right one side opening	Shine gray	26
	NK153SR-SC	NK153SL-SC							○	85° and 150°			
	NK153R TRISET-SC	NK153L TRISET-SC		1000	2200	8 10 12	80	20.0	-	-			
	NK153SR TRISET-SC	NK153SL TRISET-SC							○	85° and 150°			
	Empty hinge NK150R-SC	NK150L-SC		-	-	-	-	-	-	-	-	-	

One set comes as a pair of hinges; a spring hinge and a damper hinge (except for empty hinges).
 The models including "R" in the model number are for the right-hand opening doors, and "L" are for the left-hand opening doors. The 300 series is non handed, can be used for both right-hand and left-hand opening doors.
 Choose left-hand or right-hand opening type when ordering.
 The models including "S" in the model number come with a hold stop function (with internal stop mechanism).
 The models with "T" or "AT" at the end of the model number have tap holes (M6) on the hinge leaf. Same model without tap holes are also available. (Example: 143R-T with tap holes, 143R without tap holes)
 The empty hinges come as a single set.

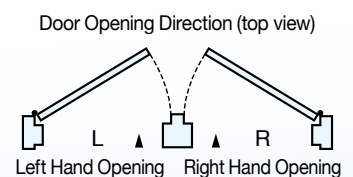

Installation procedure

300 series - P. 27, 1000 series - P. 28, 1000F series - P. 29, 2000 series - P. 30, 100/200/NK series - P. 31, 700 series - P. 32, PC series - P. 33

Mounting position / Handling precautions - P. 34

Extending comfort in many different scenes.

Nitto Kohki's Flag Type Auto Hinges

Suitable for all kinds of swing doors. Offers aesthetic appearance to the door.

Flag Type

300, 1000, 2000, 100, and 200 series

Simple design

The Auto Hinge is a door hinge with integrated door closer, providing the door a neat-looking. The simple and beautiful design matches different door styles.

Wide range of application

The Auto Hinge can be also used on the arch doors or doors without top jamb for which the common overhead door closers are not readily compatible.

Sufficient door-closing power

The 100 and 200 series incorporate two different springs (weak and strong) along with a clutch switching mechanism, exhibiting sufficient door-closing power even with its slim body.

Internal stop mechanism

The "S" models come with an automatic mechanism that stops and holds the door. With the 300 series, stops at any position from 85° to 180° (free stops). With the 1000 series, at any position from 85° to 180° (free stops) or at 85°. With the 100 and 200 series, at 85° and 150°.

Simple adjustment for closing speed

The door closing speed can be easily adjusted with a screwdriver.

Easy to install

The Auto Hinges are installed in exactly the same manner as conventional flag-type hinges. Installation can be done easily with minimal time and labor.

Outstanding durability

The Auto Hinge is designed and constructed as to undergo minimum friction, achieving outstanding durability and long life time.

Table of applicable door size:

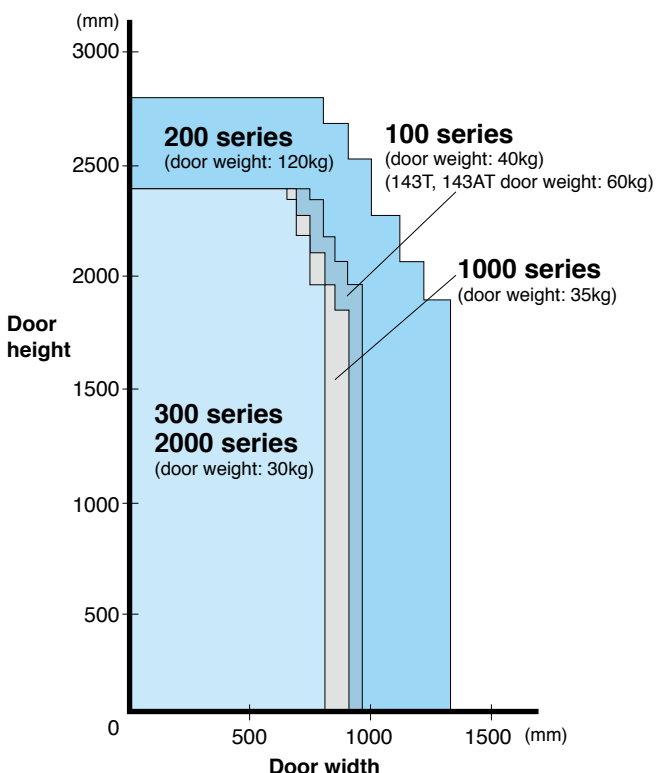

Spring hinge

(with an internal self-closing and stop mechanism)

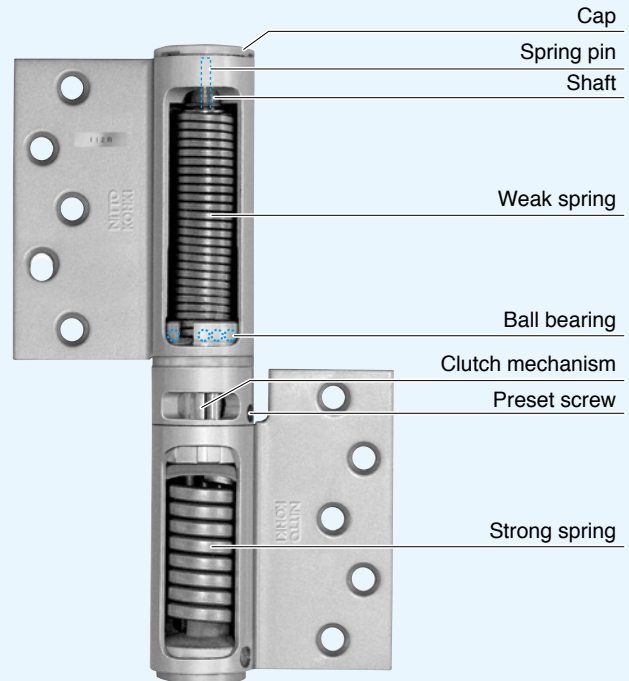

Damper hinge

(with an internal control mechanism for closing speed)

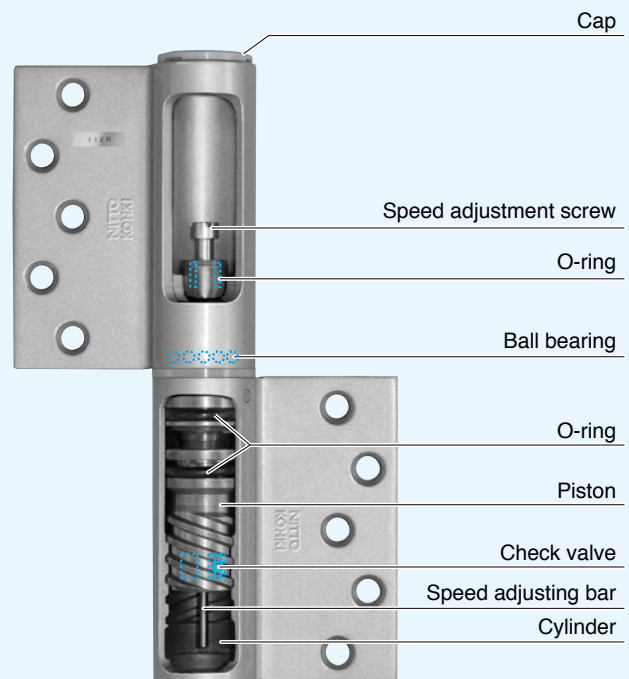

- Each model consists of a spring hinge and a damper hinge.
- This diagram represents the structure of the 100 series.

Model Number		Door Size Applicable (mm)			Door Weight (kg)	Closing Force (N·m)	Stop Mechanism	Location of Stop	Max. Opening Angle	Surface Color
		W	H	D						
311S		800(Max)	2000(Max)	30(Min)	30(Max)	5.0	○	85°~180°	180° Left or Right One-side Opening	Silver Bronze ivory gold
Empty Hinge	310					—	—	—		

● Available for both right-opening and left-opening doors.



EXTERNAL DIMENSIONS

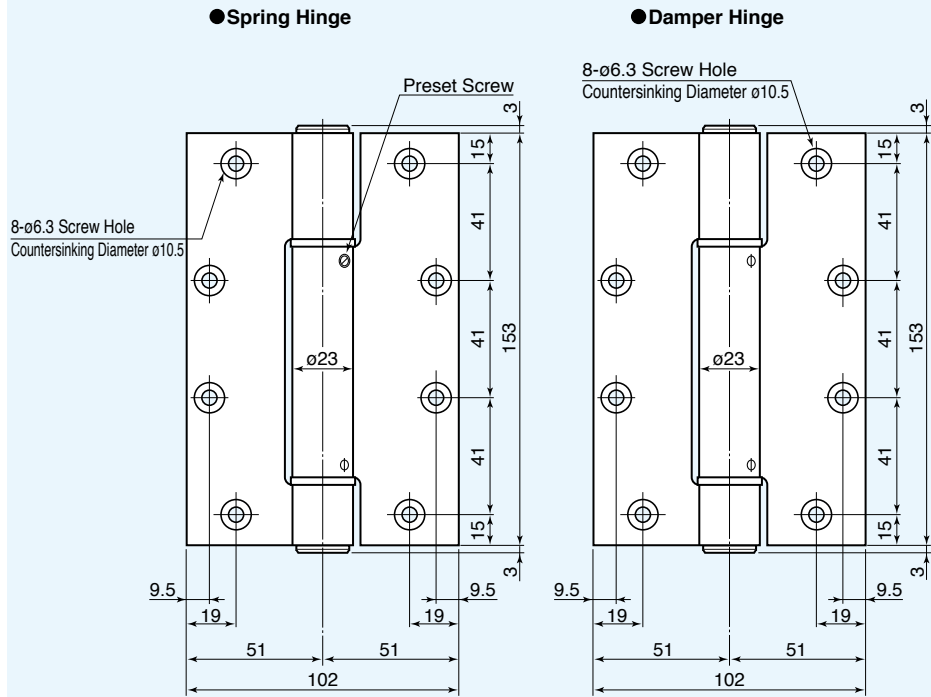

Remarks

1. Surface treatment: By baked coating of melamine resin.
2. If using on the wooden doors: The door must be made of hard wood such as lauan or harder.
3. The tapping screws supplied with the products for fitting are 25mm long. In case of using the hinges on the wooden frame, make sure that the frame is thicker than 25mm. In case of using on an aluminum or lightweight steel doors, prepare metal screws (M5 countersunk head screws).
4. Allow at least 3mm of space between the outer edge of door and the frame.

FITTING DIAGRAMS

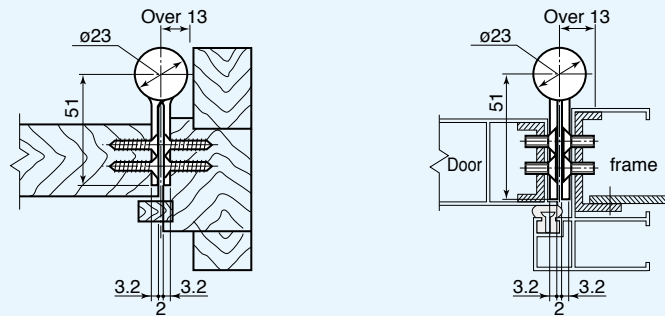

Wooden Doors

Aluminium Doors

1000series Model 1100

Model Number		Door Size Applicable(mm)			Door Weight (kg)	Closing Force (N·m)	Stop Mechanism	Location of Stop	Max. Opening Angle	Surface Color	
Right hand door	Left hand door	W	H	D							
1111R	1111L	850(Max)	2000(Max)	30(Min)	35(Max)	7.9	—	—	180° Left or Right One-side Opening	Silver	
1111SR	1111SL										85°
1121R	1121L										—
1121SR	1121SL									85°	
1111FR	1111FL									85°~180° (Free stop)	
1121FR	1121FL									—	
Empty Hinge	1110R	1110L	—	—	—	—	—	—	—	Silver	
	1120R	1120L								Bronze	

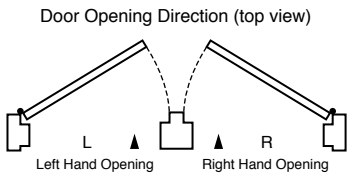

Remarks

1. The door and frame materials to which the hinge is to be fitted should be of hard wood such as lauan or harder.
2. The tapping screws supplied with the products for fitting are 25mm long. In case of using the hinges on the wooden frame, make sure that the frame is thicker than 25mm.
3. Allow at least 5mm of space between the outer edge of door and the frame.
4. Body material : Aluminum
Surface treatment :
Silver(anodic oxide coating)
Bronze(baked epoxy resin coating)

EXTERNAL DIMENSIONS

Left Hand Door

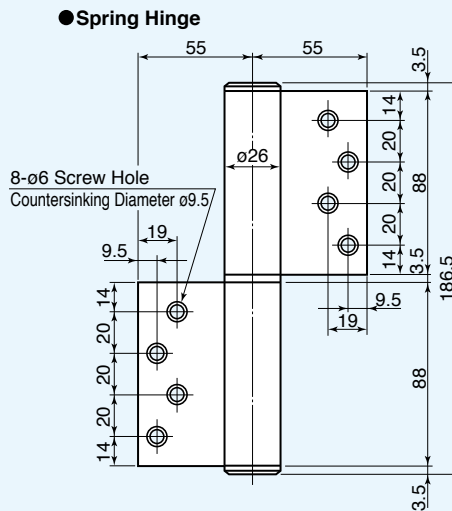

Right Hand Door

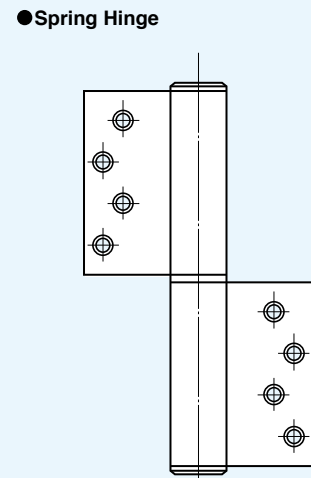

● Damper Hinge

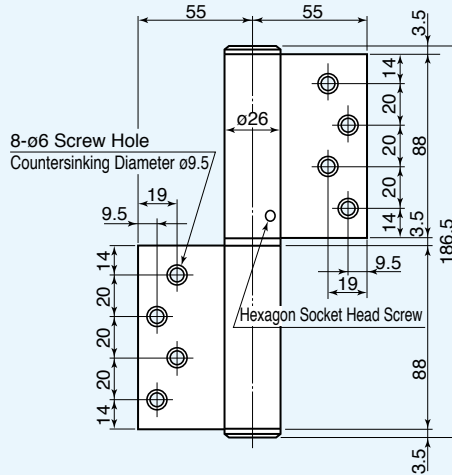

● Damper Hinge

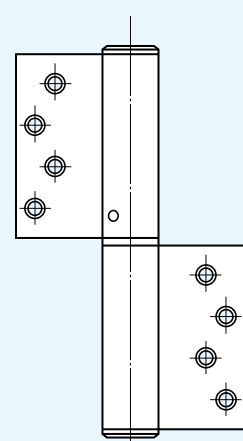

FITTING DIAGRAMS

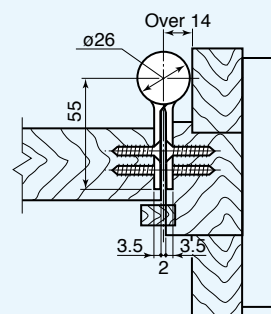
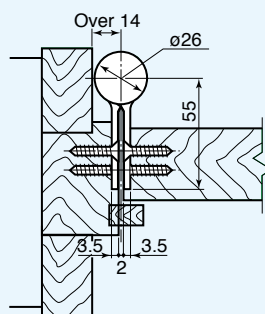

Model Number		Door Size Applicable(mm)			Door Weight (kg)	Closing Force (N-m)	Stop Mechanism	Location of Stop	Max. Opening Angle	Surface Color
Right hand door	Left hand door	W	H	D						
1211R	1211L	850(Max)	2000(Max)	30(Min)	35(Max)	7.9	—	—	180° Left or Right One-side Opening	Silver
1211SR	1211SL						○	85°		Bronze
1221R	1221L						—	—		Bronze
1221SR	1221SL						○	85°		Silver
1211FR	1211FL						○	85°~180° (Free stop)		Bronze
1221FR	1221FL						—	—		Silver
Empty Hinge	1210R	1210L	—	—	—	—	—	—	Silver	
	1220R	1220L							Bronze	



Door Opening Direction (top view)

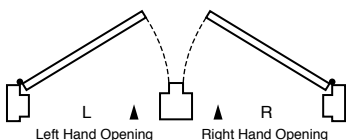

Remarks

1. For reinforcement purpose, put a steel plate of at least 2.3mm thick and 300mm long at the point of the door/frame that the hinge leaves will be fitted.
2. Use the screws included in package for installation.
3. Allow at least 5mm of space between the outer edge of door and the frame.
4. Body material : Aluminum
Surface treatment :
Silver(anodic oxide coating)
Bronze(baked epoxy resin coating)

EXTERNAL DIMENSIONS

Left Hand Door

● Spring Hinge

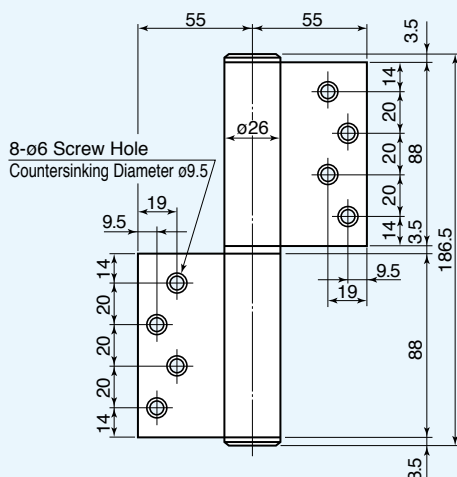

Right Hand Door

● Spring Hinge

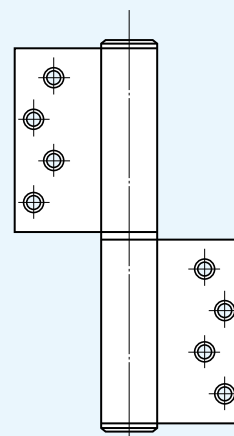

● Damper Hinge

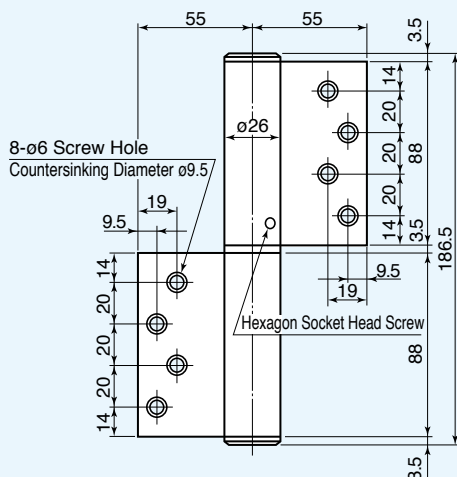

● Damper Hinge

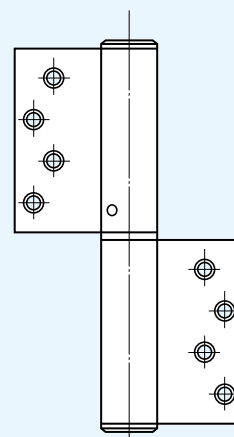

FITTING DIAGRAMS

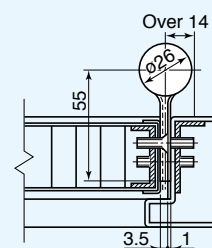
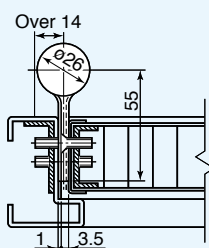

2000series Model 2200

Model Number		Door Size Applicable(mm)			Door Weight (kg)	Closing Force (N-m)	Stop Mechanism	Location of Stop	Max. Opening Angle	Surface Color	
Right hand door	Left hand door	W	H	D							
2211R	2211L	800(Max)	2000(Max)	30(Min)	35(Max)	—	—	—	180° Left or Right One-side Opening	Silver	
2211WR	2211WL										
Empty Hinge	2210R										2210L
	2210WR										2210WL

*The models including "W" in the model number are for the wooden doors, others for the aluminum / lightweight steel doors.



EXTERNAL DIMENSIONS

Left Hand Door

● Spring Hinge

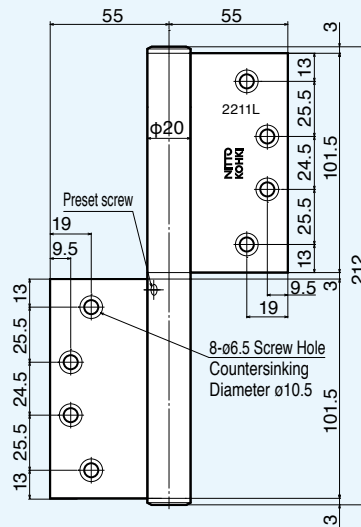

Right Hand Door

● Spring Hinge

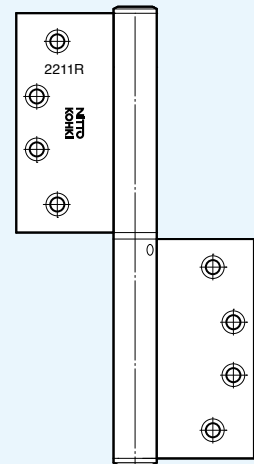

● Damper Hinge

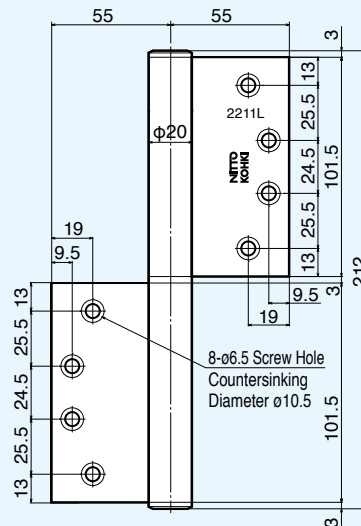

● Damper Hinge

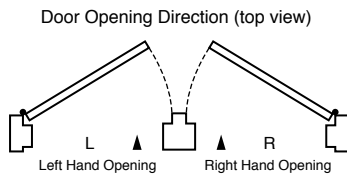
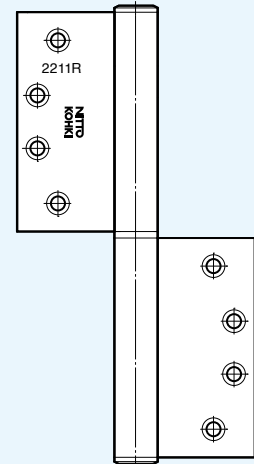

Remarks

- For reinforcement purpose, put a steel plate of at least 2.3mm thick and 300mm long at the point of the door/frame that the hinge leaves will be fitted for aluminum/light weight steel door and frame.
- The wooden door and frame materials to which the hinge is to be fitted should be of hard wood such as lauan or harder. And the tapping screws supplied with the products for fitting are 25mm long. In case of using the hinges on the wooden frame, make sure that the frame is thicker than 25mm.
- Allow at least 5mm of space between the outer edge of door and the frame.
- Body material : Aluminum
Surface treatment : Silver(anodic oxide coating)

FITTING DIAGRAMS

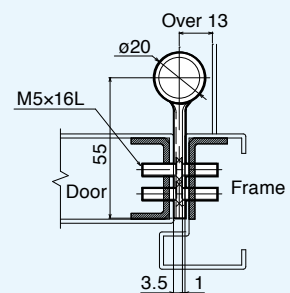
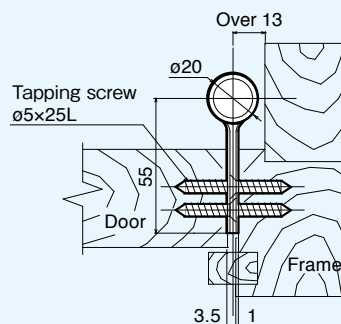

Model Number			Door Size Applicable(mm)			Door Weight (kg)	Closing Force (N-m)	Stop Mechanism	Location of Stop	Max. Opening Angle	Surface Color
Right hand door	Left hand door	W	H	D							
113R	113L	900(Max)	2100(Max)	30(Min)	60(Max)	15.0	—	—	180° Left or Right One-side Opening	Silver	
113SR	113SL										
Empty Hinge	110R										110L

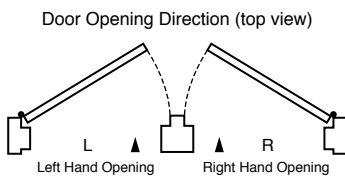

Remarks

1. The door and frame materials to which the hinge is to be fitted should be of hard wood such as lauan or harder.
2. The tapping screws supplied with the products for fitting are 25mm long. In case of using the hinges on the wooden frame, make sure that the frame is thicker than 25mm.
3. Allow at least 5mm of space between the outer edge of door and the frame.
4. The edge corner models are available too.
5. Surface treatment: By baked coating of melamine resin.
6. Always install a door stopper to prevent the door from opening more than 180°.

EXTERNAL DIMENSIONS

Left Hand Door

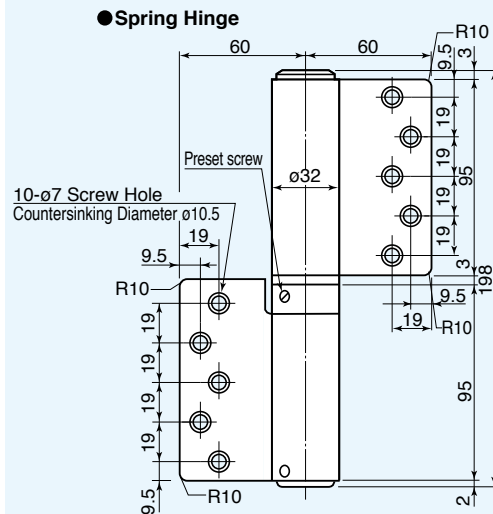

Right Hand Door

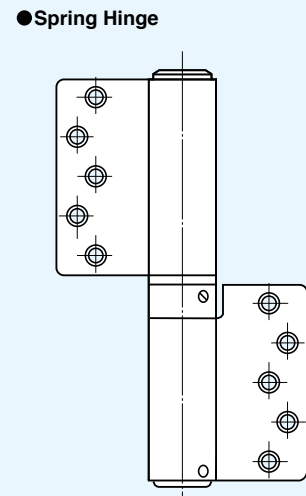

● Damper Hinge

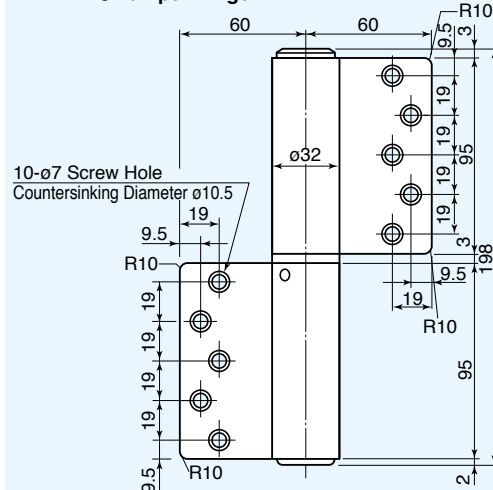

● Damper Hinge

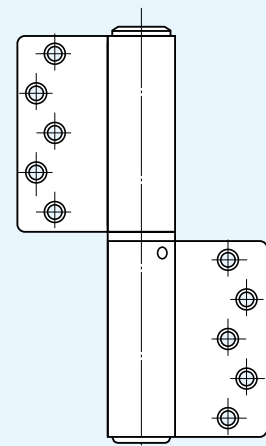

FITTING DIAGRAMS

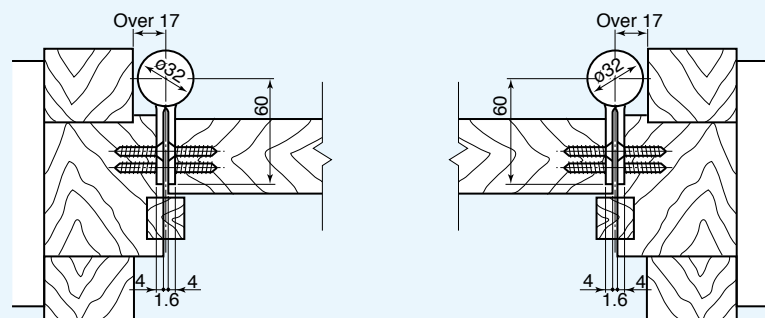

100series

Model 113 TRISET

Model Number		Door Size Applicable(mm)			Door Weight (kg)	Closing Force (N-m)	Stop Mechanism	Location of Stop	Max. Opening Angle	Surface Color
Right hand door	Left hand door	W	H	D						
113R TRISET	113L TRISET	1000(Max)	2200(Max)	30(Min)	80(Max)	20.0	—	—	180° Left or Right One-side Opening	Silver
113SR TRISET	113SL TRISET									
—		—			—		—		—	



EXTERNAL DIMENSIONS

Left Hand Door

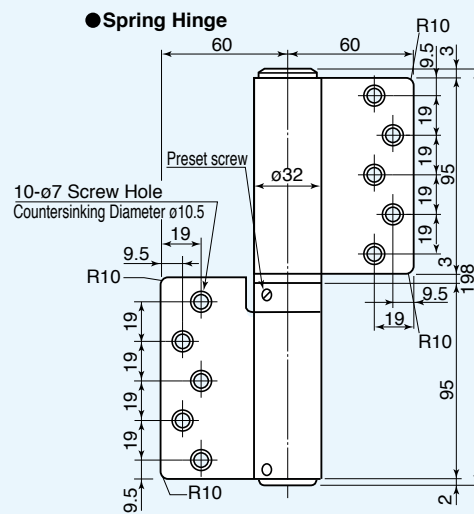

Right Hand Door

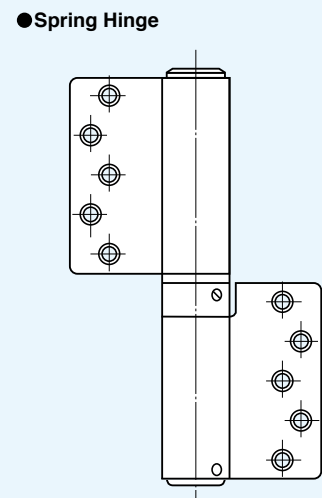

● Damper Hinge

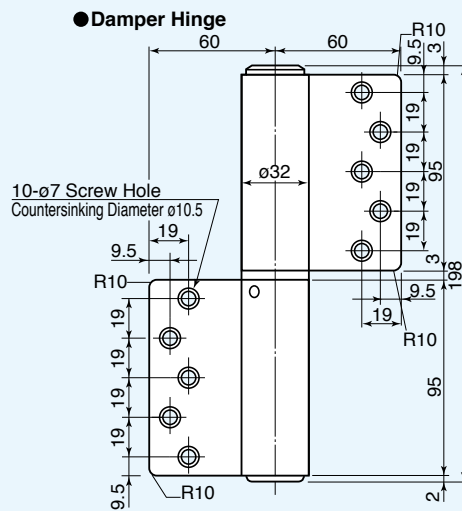

● Damper Hinge

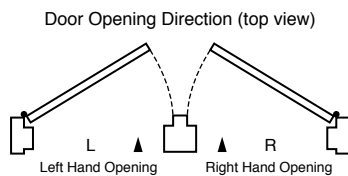
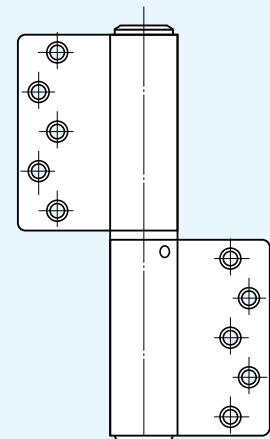

Remarks

1. The door and frame materials to which the hinge is to be fitted should be of hard wood such as lauan or harder.
2. The tapping screws supplied with the products for fitting are 30mm long. In case of using the hinges on the wooden frame, make sure that the frame is thicker than 30mm.
3. Allow at least 5mm of space between the outer edge of door and the frame.
4. The edge corner models are available too.
5. Surface treatment: By baked coating of melamine resin.
6. Always install a door stopper to prevent the door from opening more than 180°.

FITTING DIAGRAMS

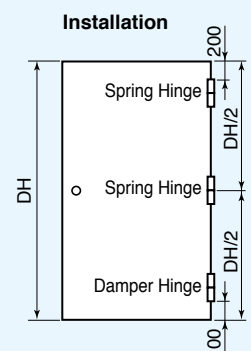
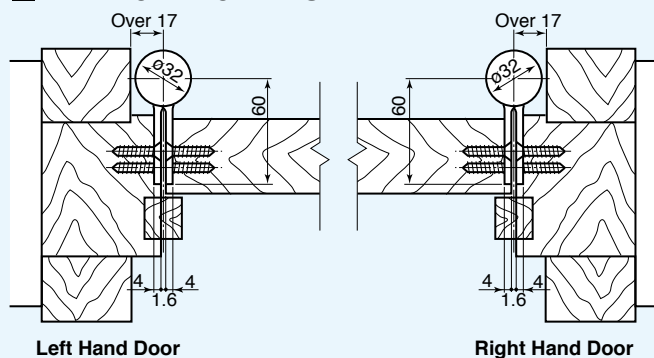

Model Number			Door Size Applicable(mm)			Door Weight (kg)	Closing Force (N·m)	Stop Mechanism	Location of Stop	Max. Opening Angle	Surface Color
Right hand door	Left hand door	W	H	D							
122R-AT	122L-AT	900(Max)	2100(Max)	30(Min)	40(Max)	10.0	—	—	180° Left or Right One-side Opening	Silver	
122SR-AT	122SL-AT						○	85° & 150°			
Empty Hinge	120R-AT					120L-AT	—	—			—



EXTERNAL DIMENSIONS

Left Hand Door

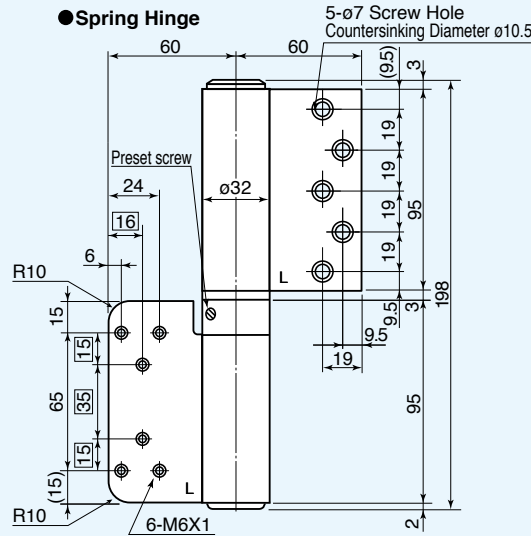

Right Hand Door

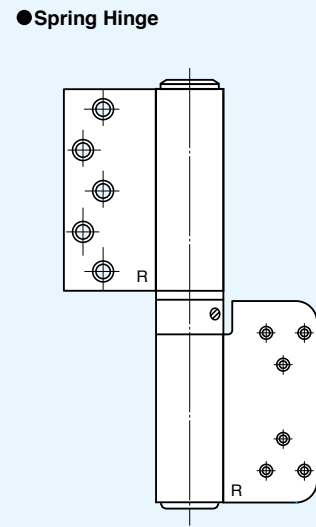

Damper Hinge

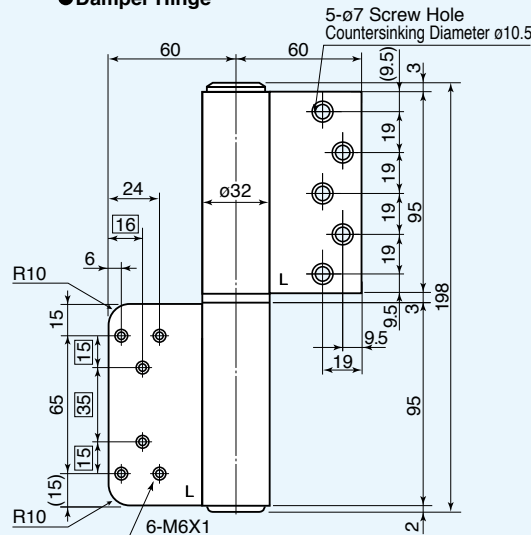

Damper Hinge

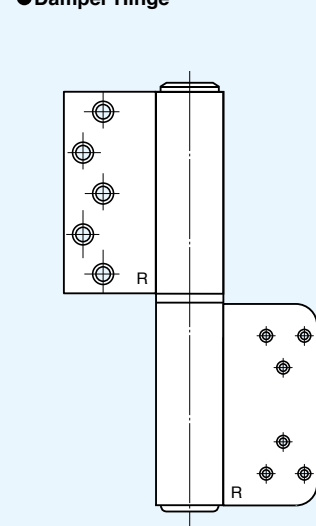

Door Opening Direction (top view)

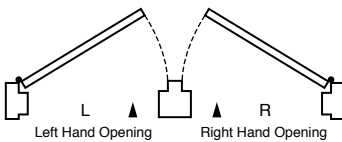

Remarks

- For reinforcement purpose, put a steel plate of at least 2.3mm thick and 300mm long at the point of the frame that the hinge leaves will be fitted.
- Use the M6 countersunk head screws for fitting. (Screws are not included). Refer to the dimensions in the square (□) when cutting the leaf. (Do NOT weld.)
- If using on the wooden doors: The door must be made of hard wood such as lauan or harder.
- Allow at least 5mm of space between the outer edge of door and the frame.
- Surface treatment: By baked coating of melamine resin.
- Always install a door stopper to prevent the door from opening more than 180°.

FITTING DIAGRAMS

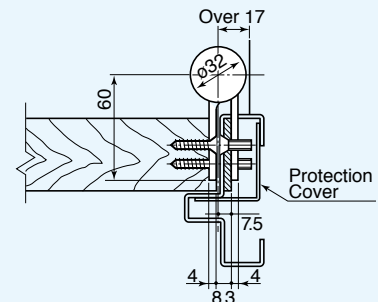
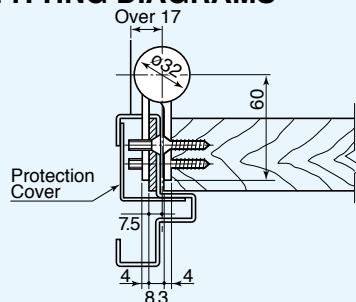

Model Number		Door Size Applicable(mm)			Door Weight (kg)	Closing Force (N-m)	Stop Mechanism	Location of Stop	Max. Opening Angle	Surface Color
Right hand door	Left hand door	W	H	D						
132R	132L	900(Max)	2100(Max)	30(Min)	40(Max)	10.0	—	—	180° Left or Right One-side Opening	Silver
132SR	132SL									
Empty Hinge	130R / 130L									



EXTERNAL DIMENSIONS

Left Hand Door

● Spring Hinge

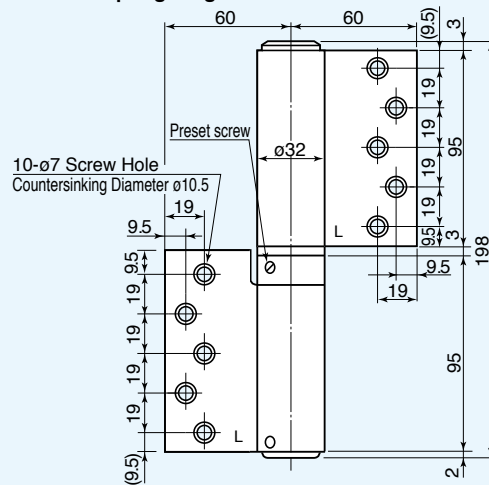

Right Hand Door

● Spring Hinge

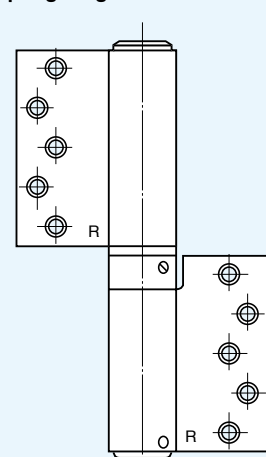

● Damper Hinge

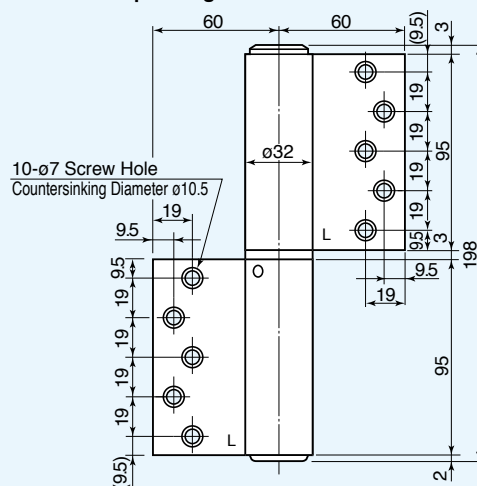

● Damper Hinge

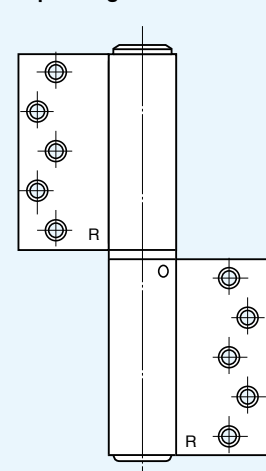

Door Opening Direction (top view)

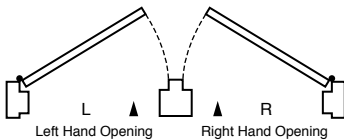

Remarks

1. For reinforcement purpose, put a steel plate of at least 2.3mm thick and 300mm long at the point of the door/frame that the hinge leaves will be fitted.
2. Use the screws included in package for installation.
3. Allow at least 5mm of space between the outer edge of door and the frame.
4. Surface treatment: By baked coating of melamine resin.
5. Always install a door stopper to prevent the door from opening more than 180°.

FITTING DIAGRAMS

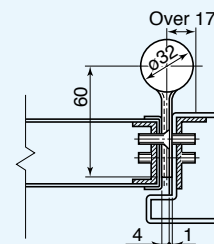
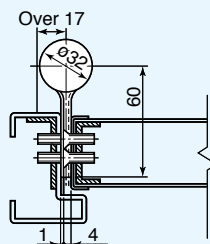

100series

Model 143T

Model Number			Door Size Applicable(mm)			Door Weight (kg)	Closing Force (N-m)	Stop Mechanism	Location of Stop	Max. Opening Angle	Surface Color	
Right hand door	Left hand door	W	H	D								
143R-T	143L-T	900(Max)	2100(Max)	30(Min)	60(Max)	15.0	—	—	180° Left or Right One-side Opening	Silver		
143SR-T	143SL-T										—	85° & 150°
Empty Hinge	140R-T / 140L-T										—	—

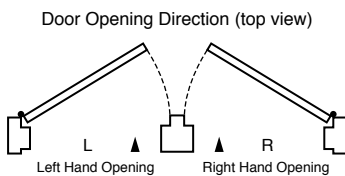

Remarks

1. For reinforcement purpose, put a steel plate of at least 2.3mm thick and 300mm long at the point of the door/frame that the hinge leaves will be fitted.
2. Use the M6 countersunk head screws for fitting. (Do NOT weld.) Screws are not included.
3. In case of applying to the fire protection door, use the model 143R-T or 143L-T without the stop function.
4. Allow at least 5mm of space between the outer edge of door and the frame.
5. Surface treatment: By baked coating of melamine resin.
6. Always install a door stopper to prevent the door from opening more than 180°.

EXTERNAL DIMENSIONS

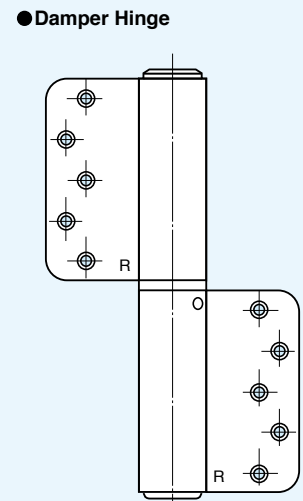
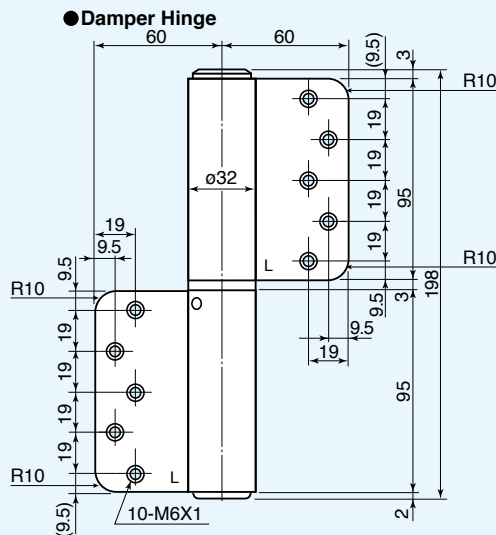
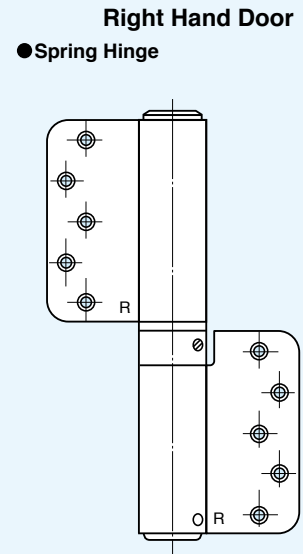
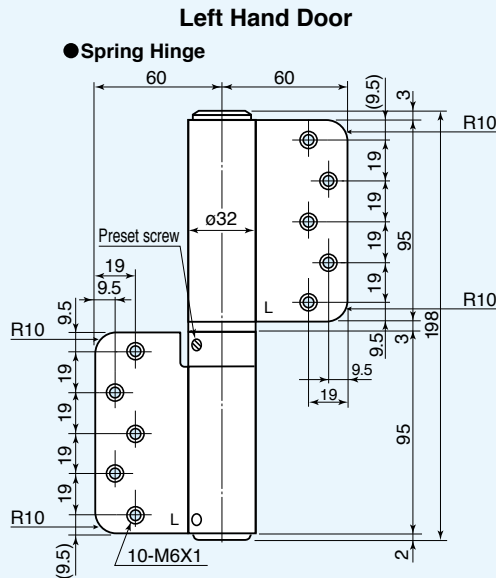

FITTING DIAGRAMS

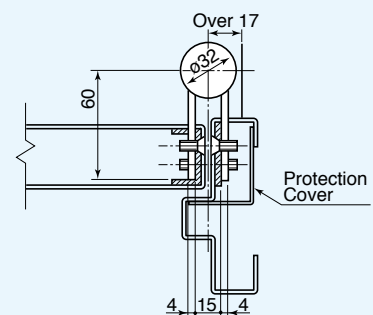
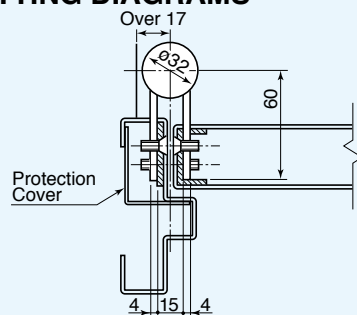

100series Model 143AT

Model Number		Door Size Applicable(mm)			Door Weight (kg)	Closing Force (N-m)	Stop Mechanism	Location of Stop	Max. Opening Angle	Surface Color
Right hand door	Left hand door	W	H	D						
143R-AT	143L-AT	900(Max)	2100(Max)	30(Min)	60(Max)	15.0	—	—	180° Left or Right One-side Opening	Silver
143SR-AT	143SL-AT									
Empty Hinge	140R-AT / 140L-AT					—	—	—		

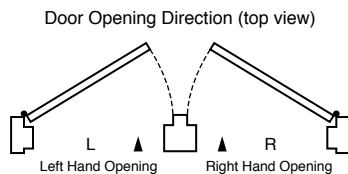

Remarks

- For reinforcement purpose, put a steel plate of at least 2.3mm thick and 300mm long at the point of the frame that the hinge leaves will be fitted.
- Use the M6 countersunk head screws for fitting. (Screws are not included.) Refer to the dimensions in the square (□) when cutting the leaf. (Do NOT weld.)
- In case of applying to the fire protection door, use the model 143R-AT or 143L-AT without the stop function.
- Allow at least 5mm of space between the outer edge of door and the frame.
- Surface treatment: By baked coating of melamine resin.
- Always install a door stopper to prevent the door from opening more than 180°.

EXTERNAL DIMENSIONS

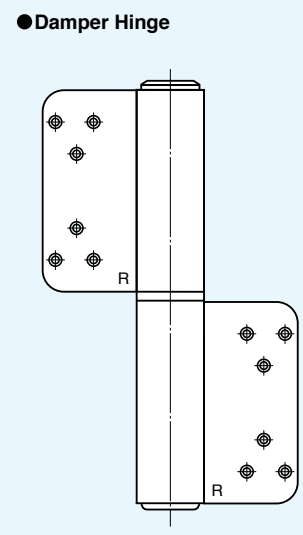
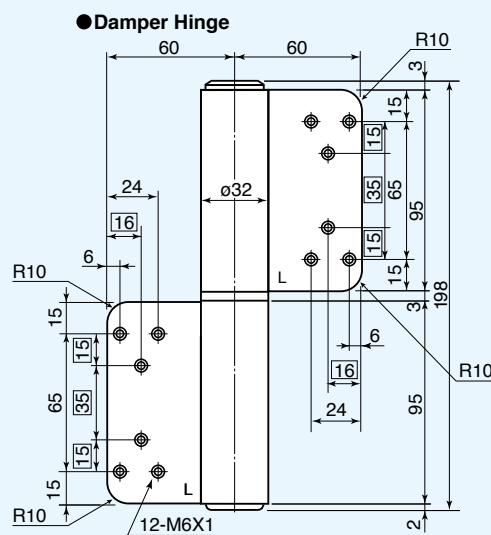
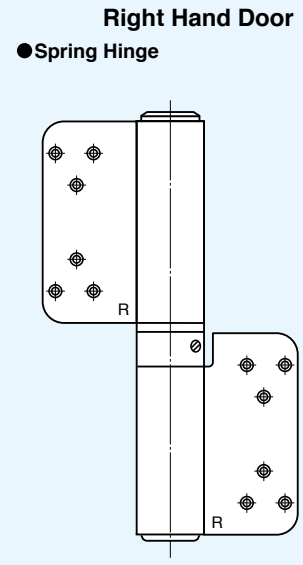
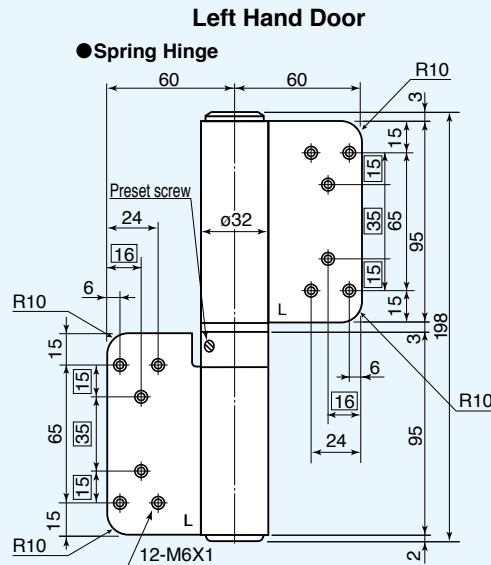

FITTING DIAGRAMS

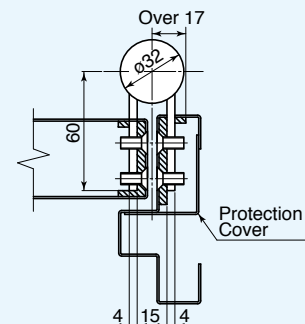
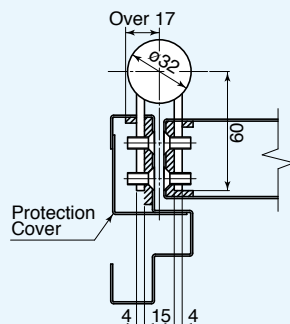

200 series

Model 234

Model Number			Door Size Applicable(mm)			Door Weight (kg)	Closing Force (N·m)	Stop Mechanism	Location of Stop	Max. Opening Angle	Surface Color
Right hand door	Left hand door	W	H	D							
234R	234L	1200(Max)	2100(Max)	40(Min)	120(Max)	22.6	—	—	180° Left or Right One-side Opening	Silver	
234SR	234SL										○
Empty Hinge	230R / 230L					—	—	—			



Door Opening Direction (top view)

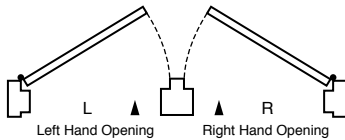

Remarks

1. For reinforcement purpose, put a steel plate of at least 3.2mm thick and 300mm long at the point of the door/frame that the hinge leaves will be fitted.
2. Use the M6x20 countersunk head screws for fitting. (Do NOT weld.)
3. Allow at least 5mm of space between the outer edge of door and the frame.
4. Surface treatment: By baked coating of melamine resin.
5. Always install a door stopper to prevent the door from opening more than 180°.

EXTERNAL DIMENSIONS

Left Hand Door

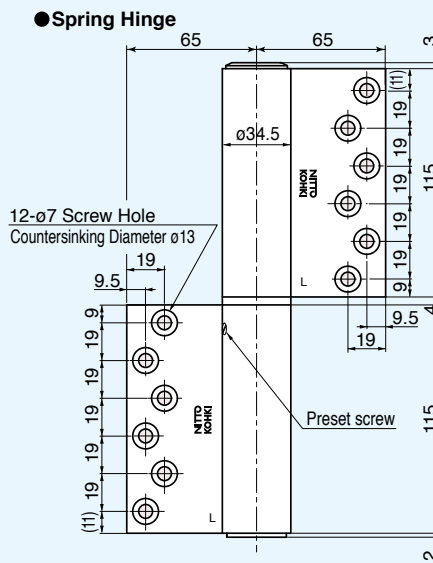

Right Hand Door

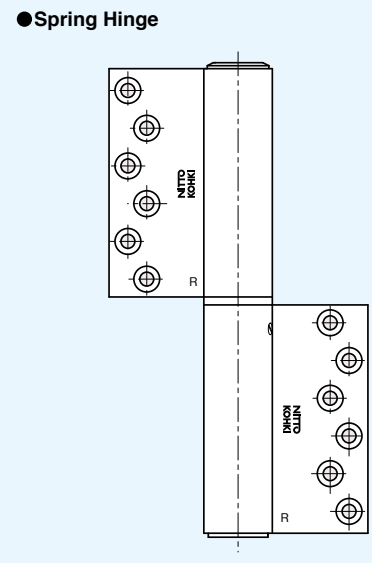

● Damper Hinge

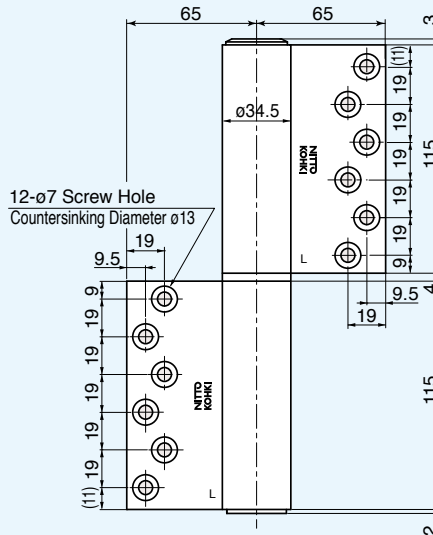

● Damper Hinge

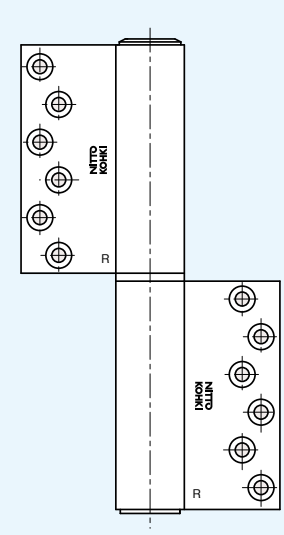

FITTING DIAGRAMS

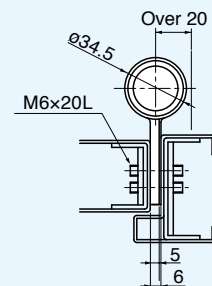
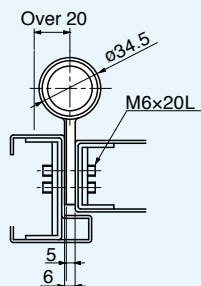

200 series Model 244T

Model Number			Door Size Applicable(mm)			Door Weight (kg)	Closing Force (N·m)	Stop Mechanism	Location of Stop	Max. Opening Angle	Surface Color
Right hand door	Left hand door	W	H	D							
244R-T	244L-T	1200(Max)	2100(Max)	40(Min)	120(Max)	22.6	—	—	180° Left or Right One-side Opening	Silver	
244SR-T	244SL-T										—
Empty Hinge	240R-T / 240L-T					—	—	—			



EXTERNAL DIMENSIONS

Left Hand Door

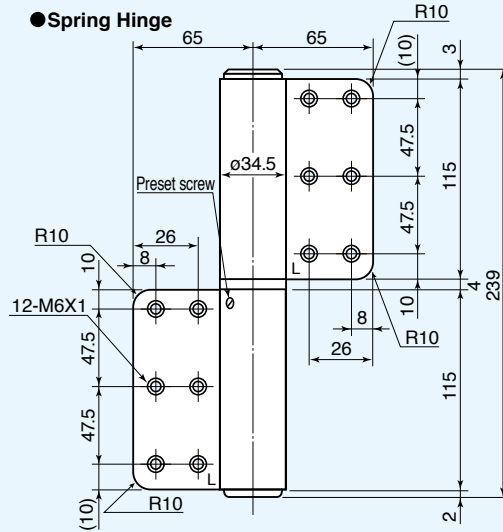

Right Hand Door

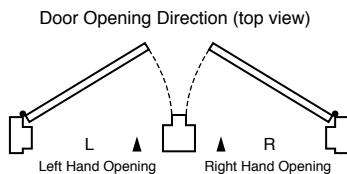
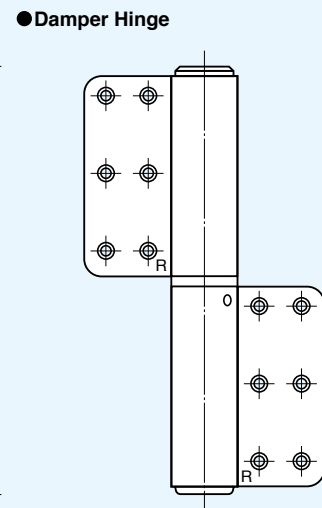
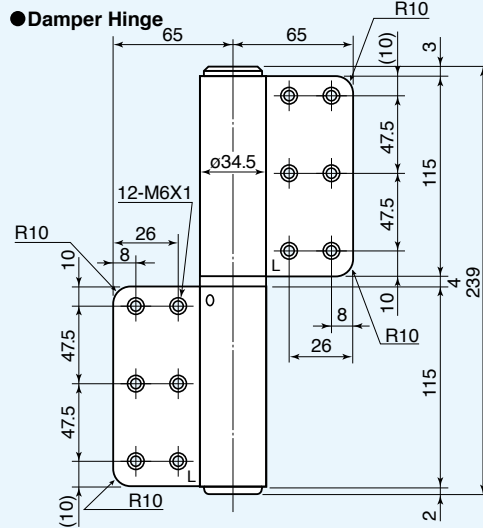
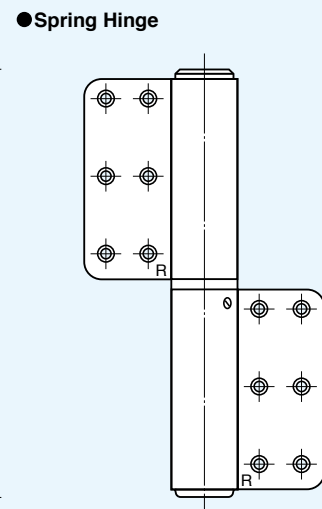

Remarks

1. For reinforcement purpose, put a steel plate of at least 3.2mm thick and 300mm long at the point of the door/frame that the hinge leaves will be fitted.
2. Use the M6 countersunk head screws for fitting. (Do NOT weld.) Screws are not included.
3. In case of applying to the fire protection door, use the model 244R-T or 244L-T without the stop function.
4. Allow at least 5mm of space between the outer edge of door and the frame.
5. Surface treatment: By baked coating of melamine resin.
6. Always install a door stopper to prevent the door from opening more than 180°.

FITTING DIAGRAMS

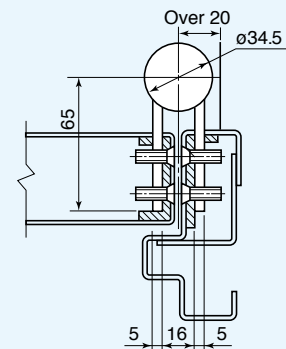
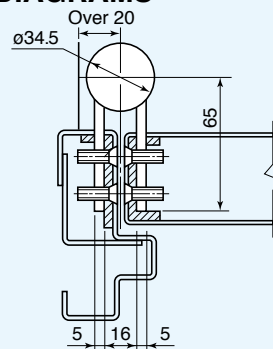

Employs special sealing technology and highly durable stainless steel.

Suitable for wide range of use, including in bathrooms and at seashores.

Offers beautiful and harmonized appearance with exterior/interior equipment.

Stainless steel, Flag Type

700 series

Simple design

The Auto Hinge is a door hinge with integrated door closer, providing the door a neat-looking. The simple and beautiful design matches different door styles.

Wide range of application

Suitable for wide range of service locations, including bathrooms, seashores and other outdoor environments.

Employs high-endurance stainless steel for rust, corrosion and stain resistance.

About three times corrosion-proof as the PC type Auto Hinge. (At least 500 hours tested in a salt spray)

Dew-proof by a special sealing structure

Achieves long life by special surface treatment.

About twice durable as the PC type Auto Hinge. (At least 200,000 open/close cycle tested)

Outstanding durability

The advanced low-friction structure achieves outstanding durability.

Internal stop mechanism

The "S" models come with an internal stop mechanism that stops and holds the door at 85° and 150°.

Simple adjustment for closing speed

The door closing speed can be easily adjusted with a screwdriver.

No need of adjusting the door-closing speed with temperature change

The 700 series adopts an actuator with unique temperature sensor.

You only need to set the ideal door closing speed at initial installation, and the closing speed stays consistent without being affected by the change in the ambient temperature.

Easy to install

The Auto Hinges are installed in exactly the same manner as conventional flag-type hinges. Installation can be done easily with minimal time and labor.

Compatible with the exterior products made of stainless steel.

Table of applicable door size for the 700 series:

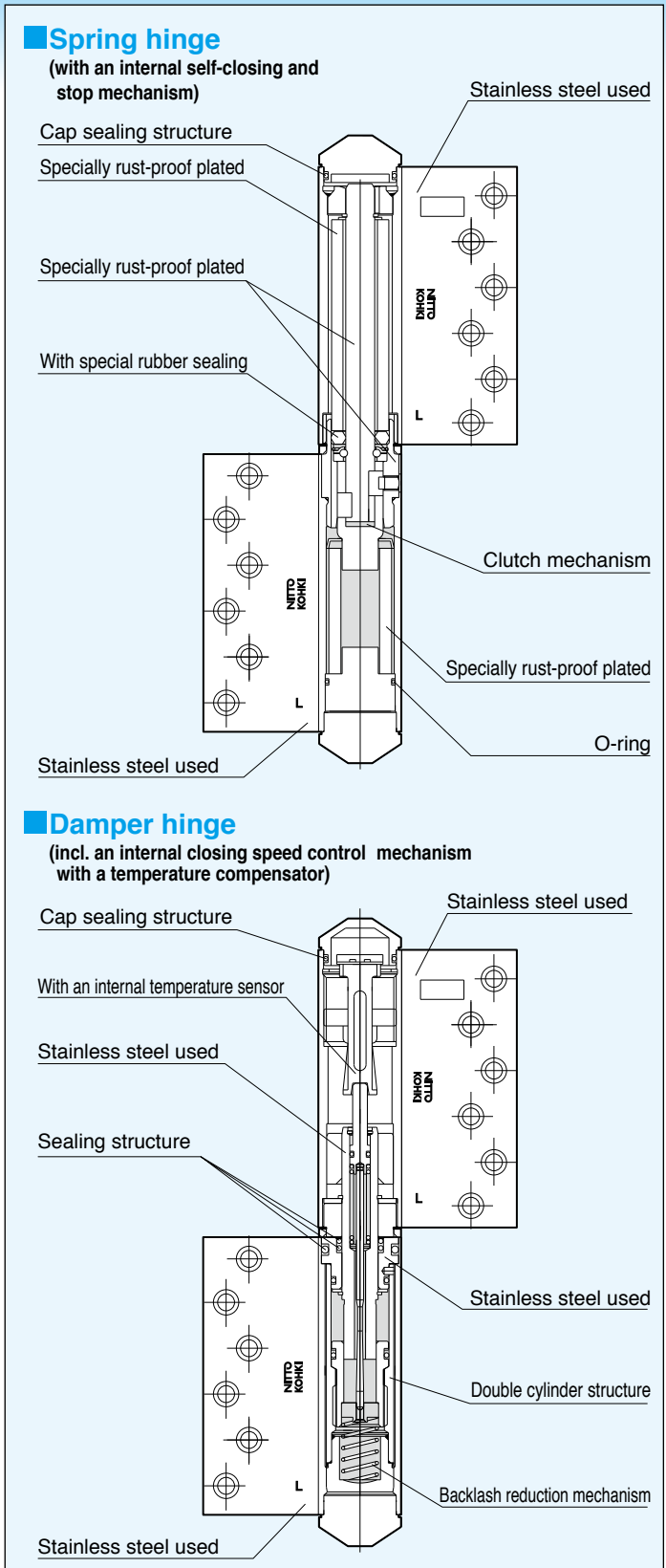
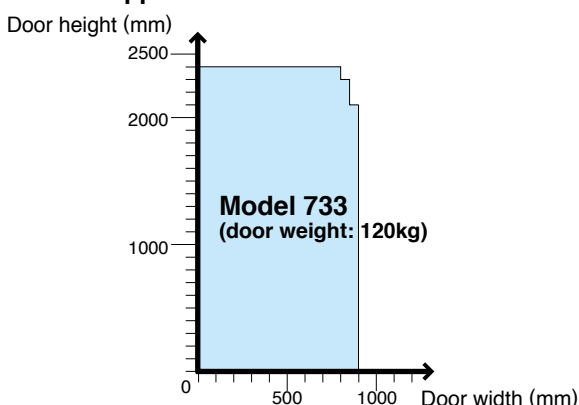

- Each model consists of a spring hinge and a damper hinge.
- This diagram represents the structure of the 700 series.

700series

Model 733

Model Number		Door Size Applicable(mm)			Door Weight (kg)	Closing Force (N-m)	Stop Mechanism	Location of Stop	Max. Opening Angle	Surface Color
Right hand door	Left hand door	W	H	D						
733R	733L	900(Max)	2100(Max)	40(Min)	120(Max)	15.0	—	85° & 150°	180° Left or Right One-side Opening	Shine gray
733SR	733SL									
Empty Hinge	730R / 730L									

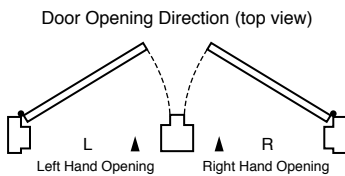

Remarks

1. Surface treatment: By baked coating of acrylic resin on the stainless steel.
2. For reinforcement purpose, put a steel plate of at least 3.2mm thick and 300mm long at the point of the door/frame that the hinge leaves will be fitted. Fix the steel plate directly on the framework.
3. M5x16 countersunk head screws are included.
4. Allow at least 5mm of space between the outer edge of door and the frame.
5. Always install a door stopper to prevent the door from opening more than 180°.
6. Avoid using them in sauna rooms.

EXTERNAL DIMENSIONS

Left Hand Door

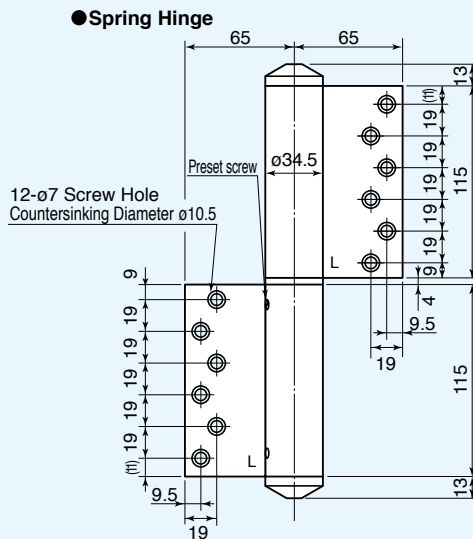

Right Hand Door

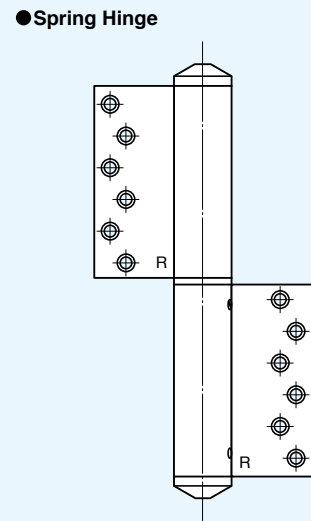

● Damper Hinge

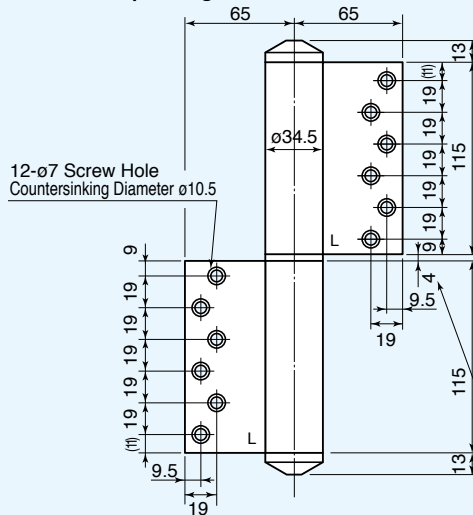

● Damper Hinge

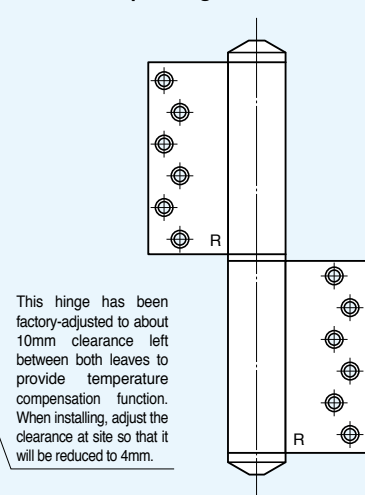

FITTING DIAGRAMS

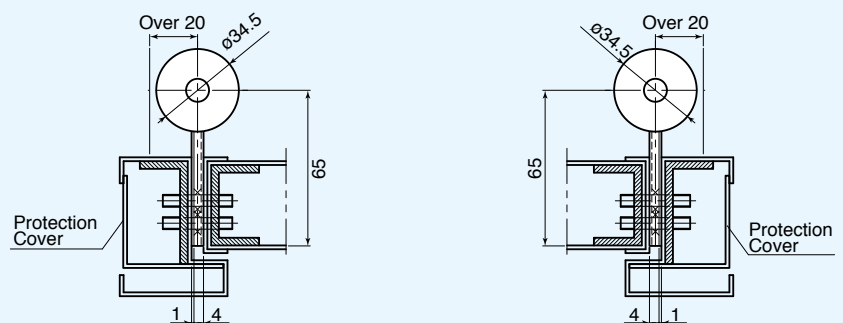

Consistent door closing speed at anytime

Various unique features (automatic temperature compensation and drip-proofing) in a slim body

Provides a neat-looking to the exterior doors.

Flag Type PC series

High reliability
in severe outdoor
environments.

Simple design

The Auto Hinge is a door hinge with integrated door closer, providing the door a neat-looking. The simple and beautiful design matches different door styles.

Drip-proof type withstanding outdoor use

Being drip-proof, the PC models can be used for entrance doors exposed to outside air and gate doors exposed directly to rain.

No need of adjusting the door-closing speed with temperature change

As the PC series has adopted the internal actuator with temperature sensor, you only need to set the ideal door closing speed at initial installation, and the closing speed stays consistent without being affected by the change in the ambient temperature.

Easy to set the door-closing speed

The door closing speed can be easily adjusted with a screwdriver.

Easy to install and handle

The PC series, as well as the other models (100/200/700 series), is installed in exactly the same manner as conventional flag-type hinges.

Outstanding durability

The Auto Hinge is designed and constructed as to undergo minimum friction, achieving outstanding durability and long life time.

Equipped with an internal stop mechanism

The models including "S" in the model number come with a hold stop function (with internal stop mechanism) and stop and hold the door at 85° and 150°.

Table of applicable door size for the PC series:

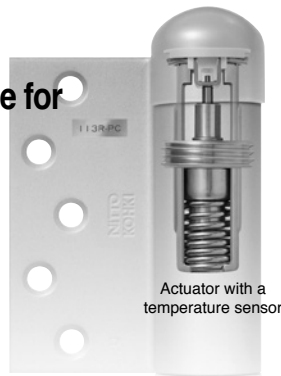
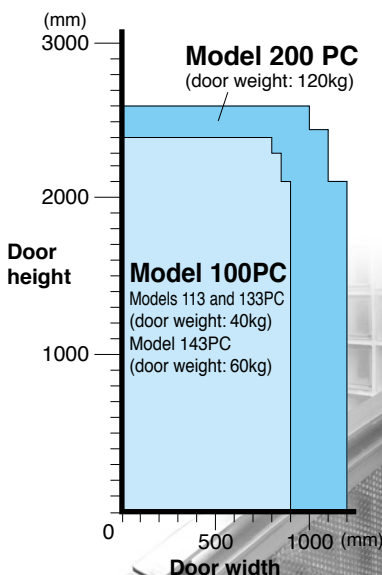

Spring hinge

(with an internal self-closing and stop mechanism)

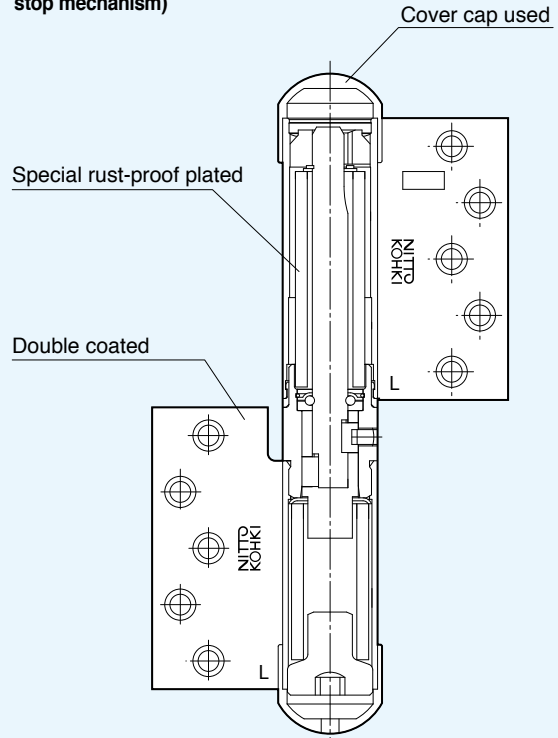

Damper hinge

(incl. an internal closing speed control mechanism with a temperature compensator)

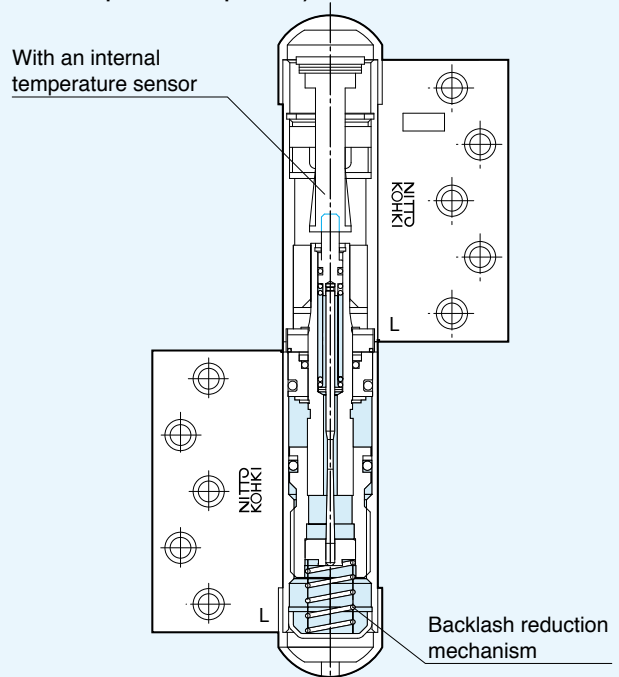

- Each model consists of a spring hinge and a damper hinge.
- This diagram represents the structure of the PC series.

Model Number			Door Size Applicable(mm)			Door Weight (kg)	Closing Force (N·m)	Stop Mechanism	Location of Stop	Max. Opening Angle	Surface Color
Right hand door	Left hand door	W	H	D							
113R-PC	113L-PC	900(Max)	2100(Max)	30(Min)	40(Max)	15.0	—	—	180° Left or Right One-side Opening	Silver * Black * Bronze	
113SR-PC	113SL-PC						○	85° & 150°			
Empty Hinge	110R-PC					110L-PC	—	—			—

※ Optional Color

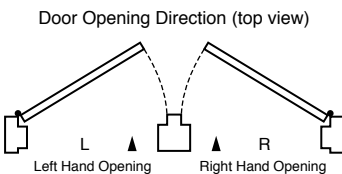

Remarks

1. Surface treatment: By baked coating of acrylic resin.
2. For reinforcement purpose, put a steel plate or a hard wooden plate (lauan or harder) of at least 2.3mm thick and 300mm long at the point of the door/frame that the hinge leaves will be fitted. Fix the plate directly on the framework.
3. The tapping screws supplied with the products for fitting are 25mm long. In case of using the hinges on the wooden frame, make sure that the frame is thicker than 25mm.
4. Allow at least 5mm of space between the outer edge of door and the frame.
5. Always install a door stopper to prevent the door from opening more than 180°.
6. Avoid using them in sauna rooms.

EXTERNAL DIMENSIONS

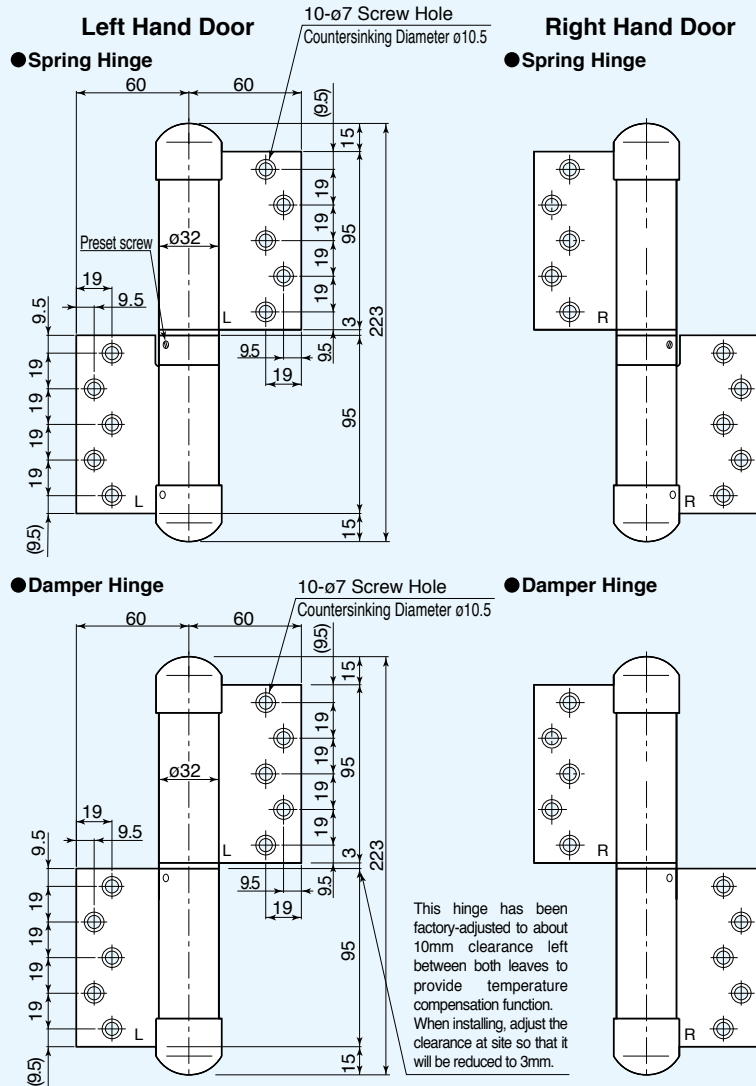

FITTING DIAGRAMS

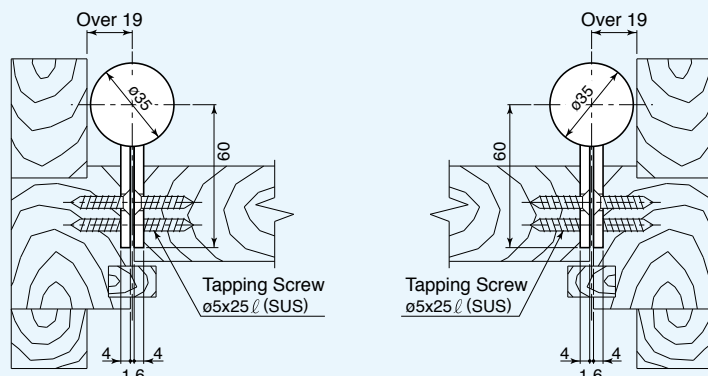

100PCseries Model 133-PC

Model Number			Door Size Applicable(mm)			Door Weight (kg)	Closing Force (N·m)	Stop Mechanism	Location of Stop	Max. Opening Angle	Surface Color
Right hand door	Left hand door	W	H	D							
133R-PC	133L-PC	900(Max)	2100(Max)	30(Min)	40(Max)	15.0	—	—	180° Left or Right One-side Opening	Silver * Black * Bronze	
133SR-PC	133SL-PC						○	85° & 150°			
Empty Hinge	130R-PC					130L-PC	—	—			—

※ Optional Color

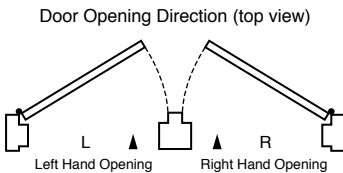

Remarks

1. Surface treatment: By baked coating of acrylic resin.
2. For reinforcement purpose, put a steel plate or a hard wooden plate (lauan or harder) of at least 2.3mm thick and 300mm long at the point of the door/frame that the hinge leaves will be fitted. Fix the plate directly on the framework.
3. M5x16 countersunk head screws are included.
4. Allow at least 5mm of space between the outer edge of door and the frame.
5. Always install a door stopper to prevent the door from opening more than 180°.
6. Avoid using them in sauna rooms.

EXTERNAL DIMENSIONS

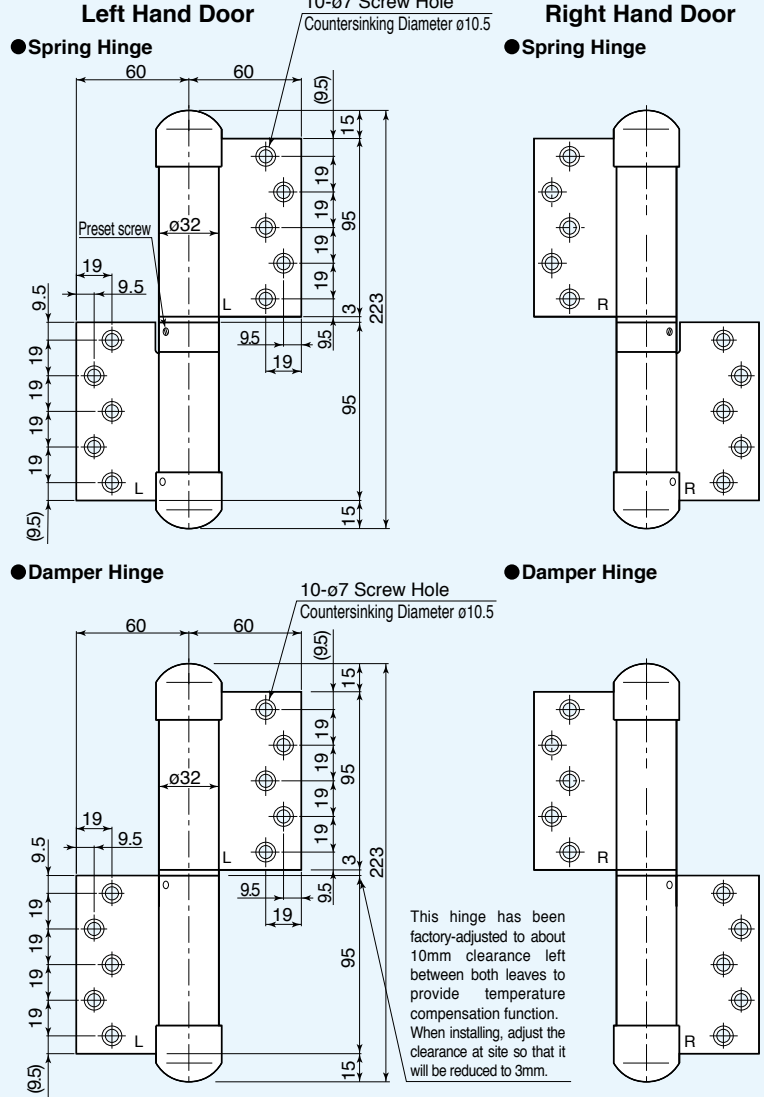

FITTING DIAGRAMS

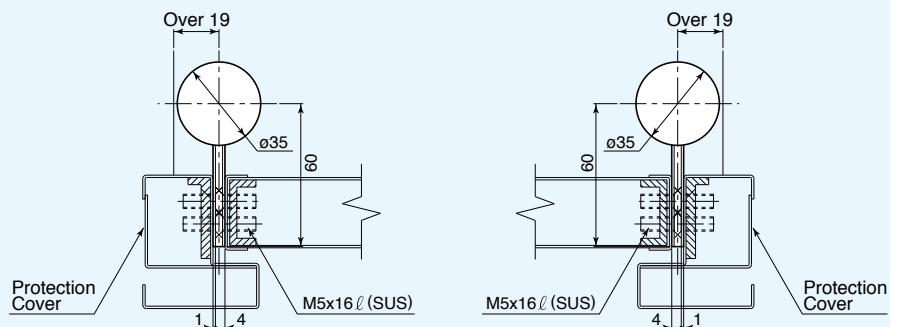

100PCseries Model 143T-PC

Model Number			Door Size Applicable(mm)			Door Weight (kg)	Closing Force (N·m)	Stop Mechanism	Location of Stop	Max. Opening Angle	Surface Color
Right hand door	Left hand door	W	H	D							
143R-T-PC	143L-T-PC	900(Max)	2100(Max)	30(Min)	60(Max)	15.0	—	—	180° Left or Right One-side Opening	Silver *Black *Bronze	
143SR-T-PC	143SL-T-PC						○	85° & 150°			
Empty Hinge	140R-T-PC / 140L-T-PC					—	—	—			

※ Optional Color



EXTERNAL DIMENSIONS

Left Hand Door

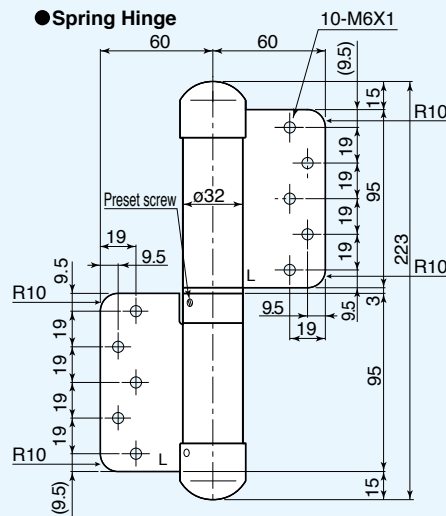

Right Hand Door

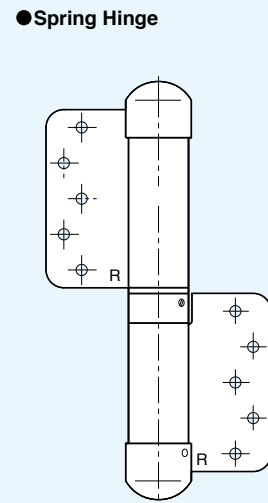

● Damper Hinge

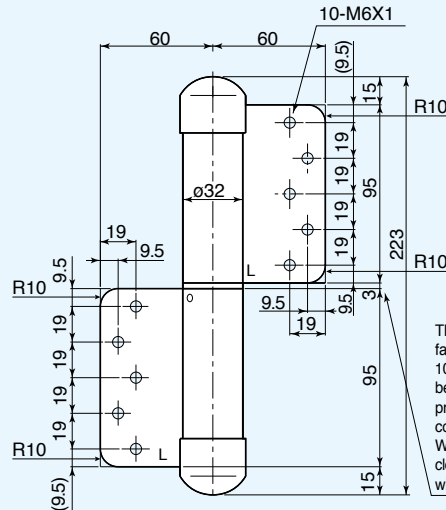

● Damper Hinge

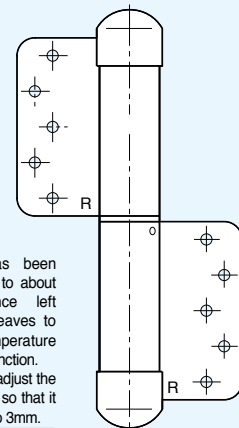

This hinge has been factory-adjusted to about 10mm clearance left between both leaves to provide temperature compensation function. When installing, adjust the clearance at site so that it will be reduced to 3mm.

FITTING DIAGRAMS

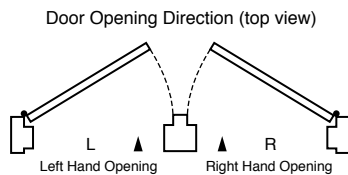
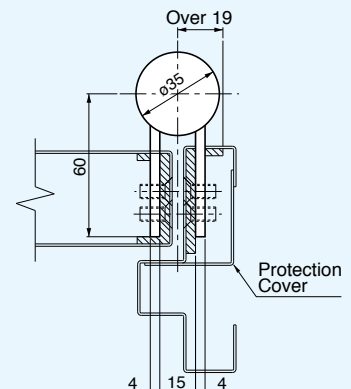
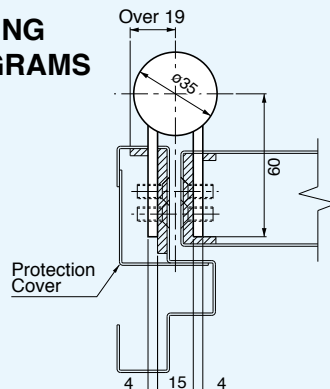

Remarks

1. Surface treatment: By baked coating of acrylic resin.
2. For reinforcement purpose, put a steel plate of at least 3.2mm thick and 300mm long at the point of the door/frame that the hinge leaves will be fitted.
3. Use the M6 countersunk head screws for fitting. (Do NOT weld.) Screws are not included.
4. Allow at least 5mm of space between the outer edge of door and the frame.
5. Always install a door stopper to prevent the door from opening more than 180°.
6. Avoid using them in sauna rooms.

200PC series Model 234-PC

Model Number			Door Size Applicable(mm)			Door Weight (kg)	Closing Force (N-m)	Stop Mechanism	Location of Stop	Max. Opening Angle	Surface Color
Right hand door	Left hand door	W	H	D							
234R-PC	234L-PC	1200(Max)	2100(Max)	40(Min)	120(Max)	22.6	—	—	180° Left or Right One-side Opening	Silver	
234SR-PC	234SL-PC										○
Empty Hinge	230R-PC / 230L-PC					—	—	—			

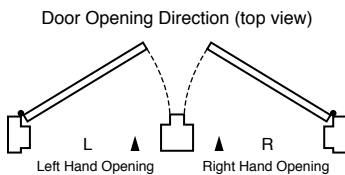

Remarks

1. Surface treatment: By baked coating of acrylic resin.
2. For reinforcement purpose, put a steel plate of at least 3.2mm thick and 300mm long at the point of the door/frame that the hinge leaves will be fitted. Fix the steel plate directly on the framework.
3. M6x20 countersunk head screws are included.
4. Allow at least 5mm of space between the outer edge of door and the frame.
5. Always install a door stopper to prevent the door from opening more than 180°.
6. Avoid using them in sauna rooms.

EXTERNAL DIMENSIONS

Left Hand Door

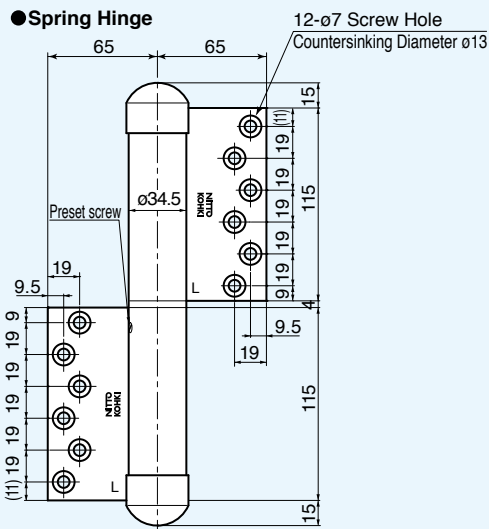

Right Hand Door

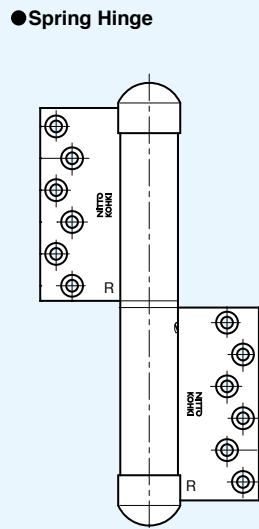

● Damper Hinge

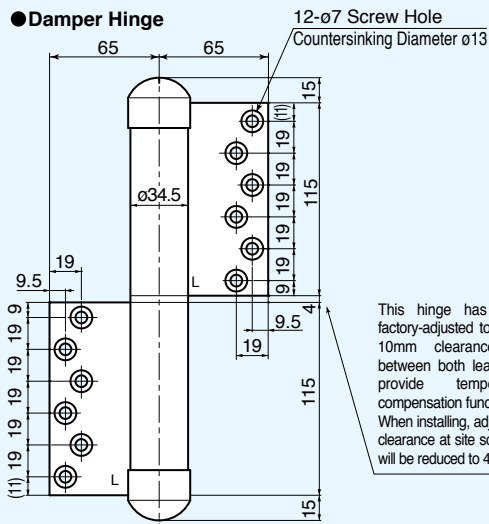

● Damper Hinge

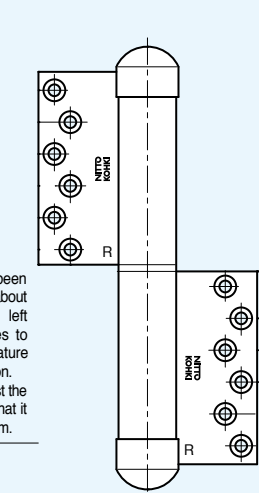

This hinge has been factory-adjusted to about 10mm clearance left between both leaves to provide temperature compensation function. When installing, adjust the clearance at site so that it will be reduced to 4mm.

FITTING DIAGRAMS

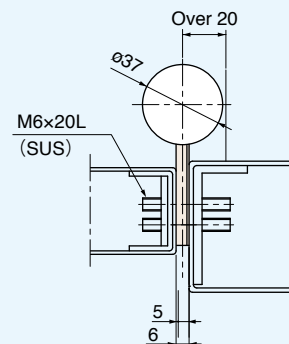
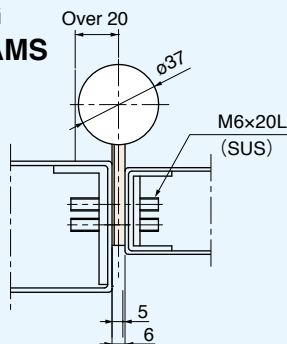

200PC series Model 244T-PC

Model Number		Door Size Applicable(mm)			Door Weight (kg)	Closing Force (N-m)	Stop Mechanism	Location of Stop	Max. Opening Angle	Surface Color		
Right hand door	Left hand door	W	H	D								
244R-T-PC	244L-T-PC	1200(Max)	2100(Max)	40(Min)	120(Max)	22.6	—	—	180° Left or Right One-side Opening	Silver		
244SR-T-PC	244SL-T-PC										○	85° & 150°
Empty Hinge	240R-T-PC / 240L-T-PC										—	—

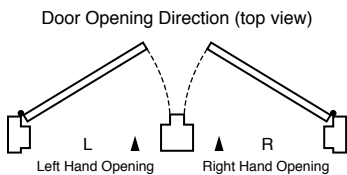

Remarks

1. Surface treatment: By baked coating of acrylic resin.
2. For reinforcement purpose, put a steel plate of at least 3.2mm thick and 300mm long at the point of the door/frame that the hinge leaves will be fitted.
3. Use the M6 countersunk head screws for fitting. (Do NOT weld.) Screws are not included.
4. Allow at least 5mm of space between the outer edge of door and the frame.
5. Always install a door stopper to prevent the door from opening more than 180°.
6. Avoid using them in sauna rooms.

EXTERNAL DIMENSIONS

Left Hand Door

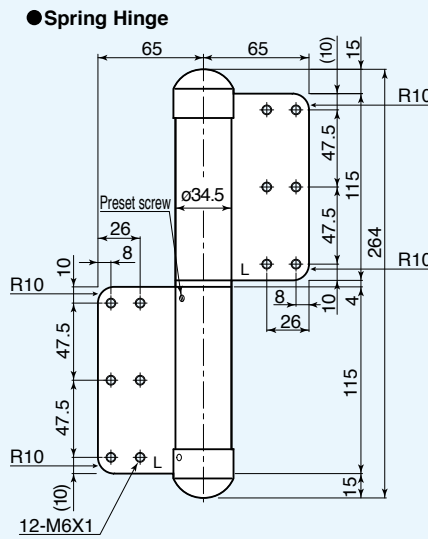

Right Hand Door

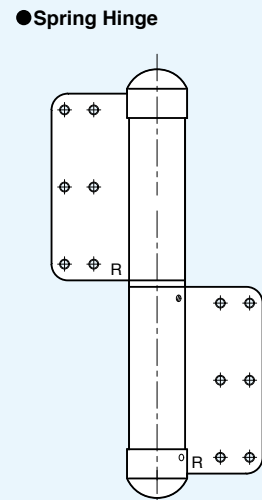

● Damper Hinge

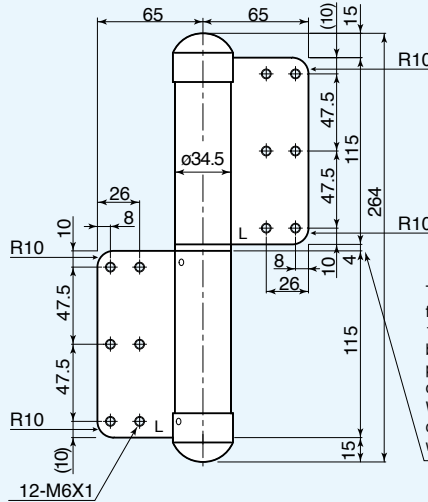

● Damper Hinge

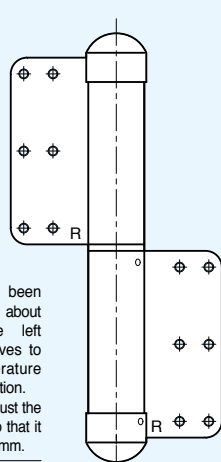

FITTING DIAGRAMS

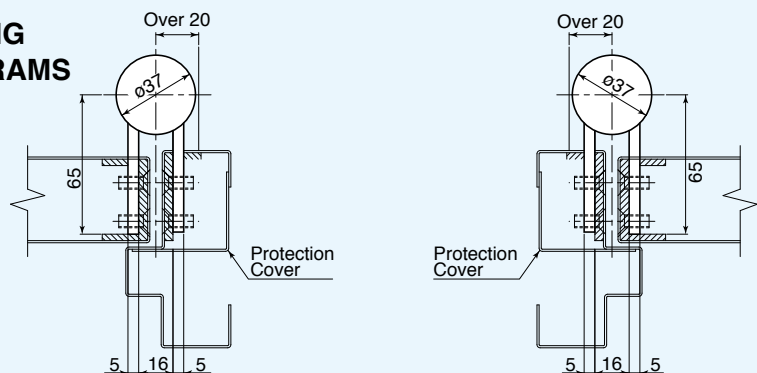

300 series

Installation procedure

- Set up the hinges after hanging the door.

Spring hinge

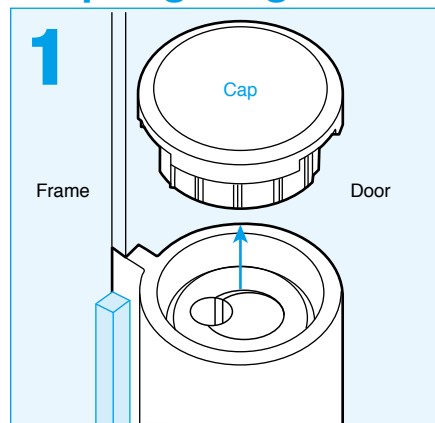

- Hang the door, then remove the cap.

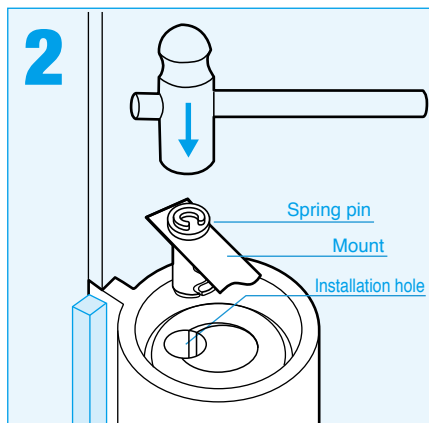

- Open the door by about 10° to 15°. Drive the supplied spring pin securely into the installation hole according to the mounting instruction. Place the cap back on the hinge.

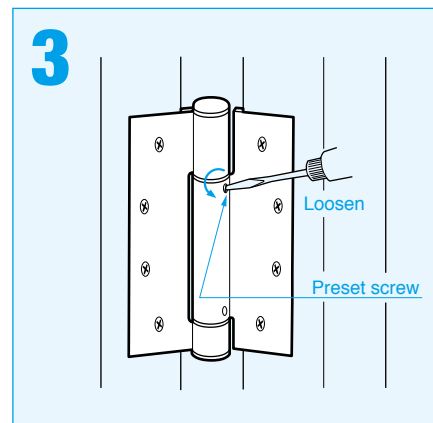

- Open the door by about 90°. Turn the preset screw counterclockwise by 3 to 4 turns, then make it stick out from the hinge surface by about 1mm.

Damper hinge

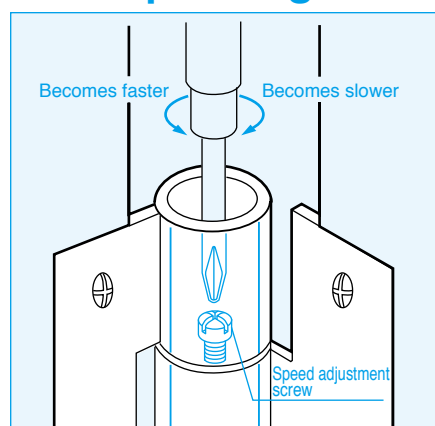

- Turn the speed adjustment screw according to the instructions given on the cap of the damper hinge, then adjust the door-closing speed. After finishing the adjustment, place the cap back on the hinge.

Cautions for installation

- Align the spring hinge and damper hinge carefully and make sure they are lined up straight.

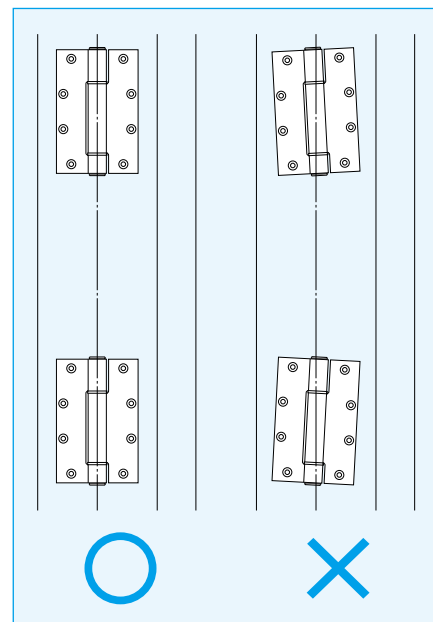

Removal of the door

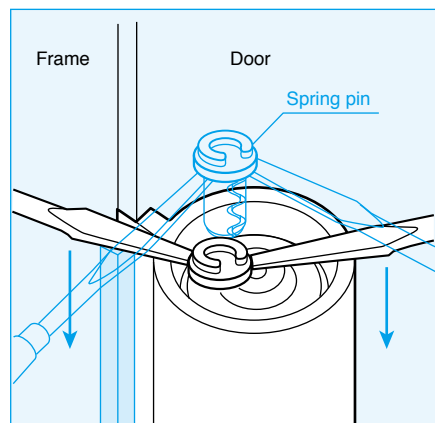

- ① Open the door by about 90°. Turn the preset screw clockwise by 3 to 4 turns. Make sure the preset screw is back to the original position as supplied from the factory.
- ② Close the door. The door should stop at about 5° position. Remove the spring pin as shown in the figure on the left. (Do not push or close the door before removing the spring pin.)
- ③ To make the spring work again, use a new spring pin.

1000 series

Installation procedure

- Set up the hinges after hanging the door.

*When hanging the door, align the notch on the shaft of the damper hinge with the hole in the door-side hinge body.

Spring hinge

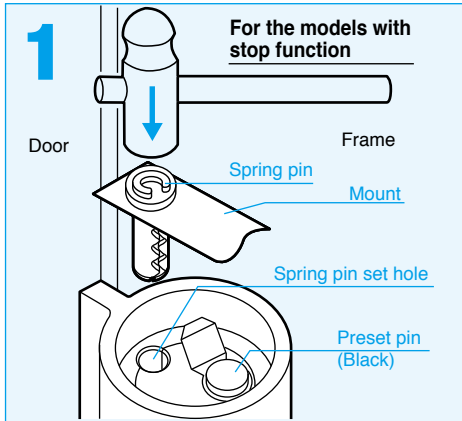

- Open the door by about 5° to 15°. Drive the spring pin (silver color) securely into the spring pin set hole according to the mounting instruction.

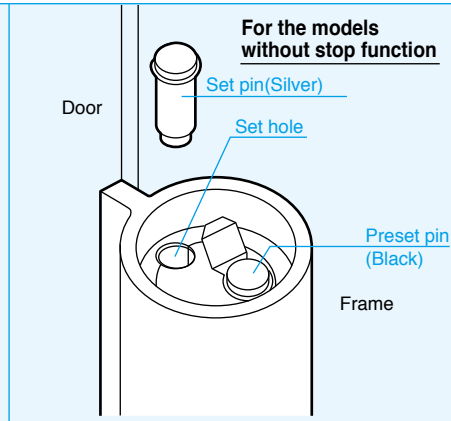

- Open the door by about 5° to 15°. Drive the set pin (silver) securely into the spring pin set hole according to the mounting instruction. The set pin is located inside the upper cap of the spring hinge.

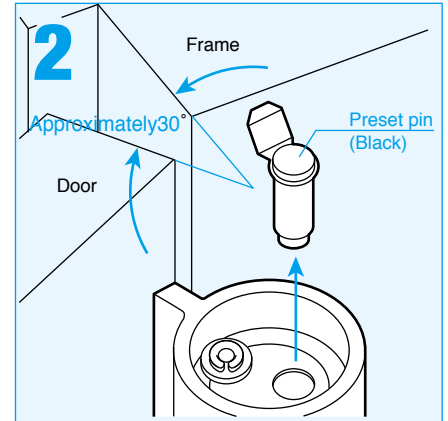

- Next, open the door by about 30°. Pull out the black pre-set pin.

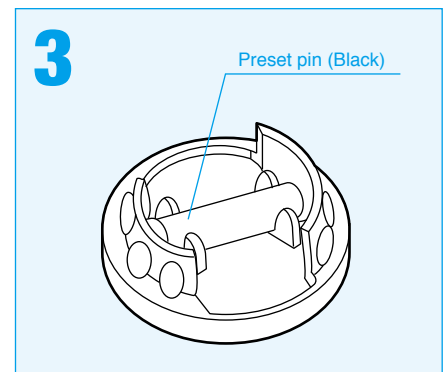

- Place the pre-set pin (black) into the cap and keep it there for future use.

Damper hinge

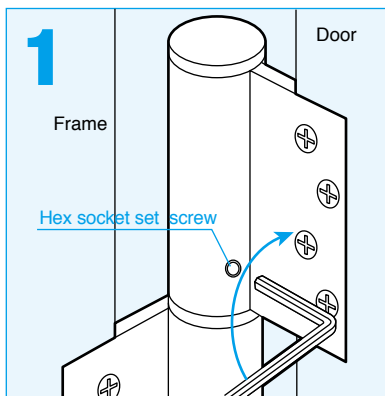

- Tighten the hex socket set screw located at the side of damper hinge with the supplied hex key.

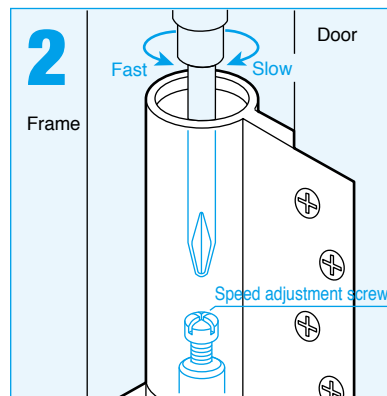

- Remove the cap. Turn the speed adjustment screw inside the damper hinge by screwdriver and adjust the door closing speed to the desired speed. Place the cap back to the hinge.

Removal of the door

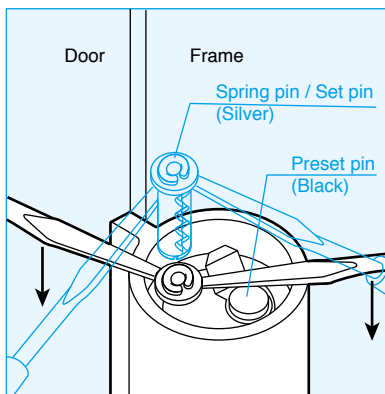

To remove the hinge from the door, follow all steps exactly backward as you installed it to the door.

- ① Loosen the shaft socket screw located at the side of damper hinge.
- ② Remove the cap from the spring hinge and take the stored pre-set pin from the cap. Open the door by about 30°. Drive the pre-set pin securely into the pre-set pin hole. (If the pre-set pin is not fixed securely, it may come out and cause the spring get loose.)
- ③ Close the door until about 5° position. Remove the spring pin as shown in the drawing on the left. Now you can take off the hinge.
- ④ It is dangerous to remove the fitting screws when the spring is still wound.

1000F series

Installation procedure

- Set up the hinges after hanging the door.

*When hanging the door, align the notch on the shaft of the damper hinge with the hole in the door-side hinge body.

Spring hinge

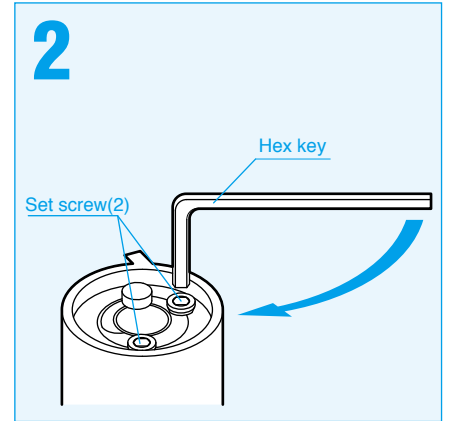
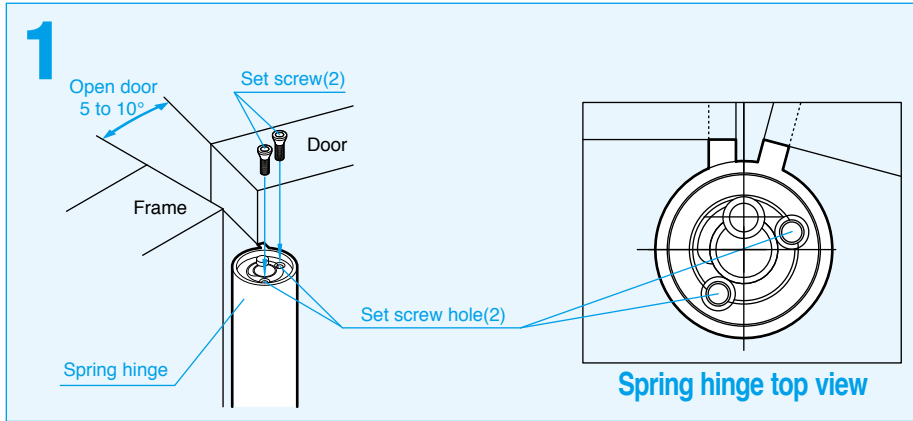

- Open the door by about 5° to 10°. Drive 2 pcs x set screws securely into the set screw holes according to the mounting instruction.
*Use the supplied set screws only.

- Tighten both set screws (M4) with the supplied hex key.

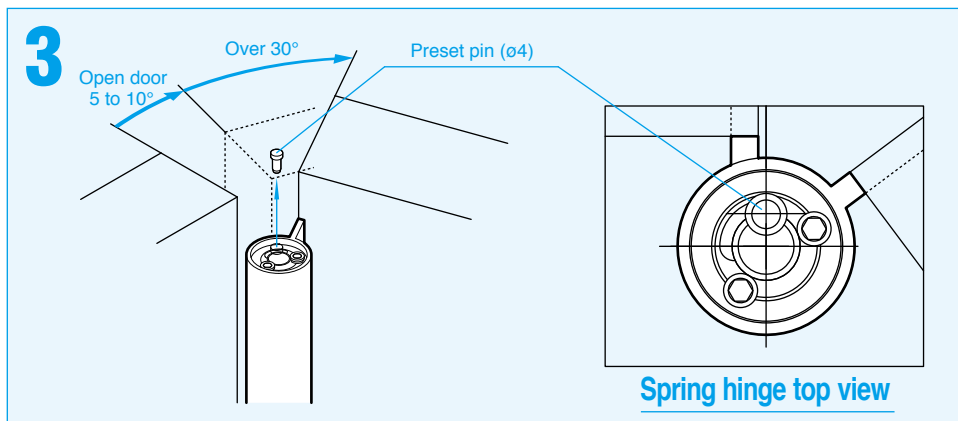

- Open the door further by additional 30° or more. Remove the pre-set pin as shown in the above figure.

Damper hinge

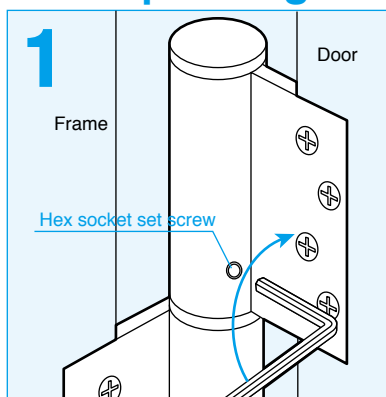

- Tighten the hex socket set screw located at the side of damper hinge with the supplied hex key.

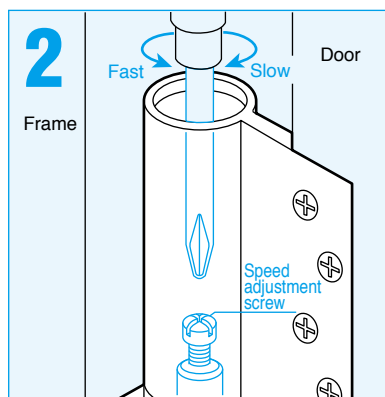

- Remove the cap. Turn the speed adjustment screw inside the damper hinge by screwdriver and adjust the door closing speed to the desired speed. Place the cap back to the hinge.

Caution

After setting, check the operation of the free stop function and confirm it works properly. Noise may be generated if the set screws (2 pcs) are loose. In such case, remove the cap from the spring hinge and tighten the set screws securely.

- If you want to use the product as regular door hinge without self-closing or stop functions, follow the instructions below.
 - ① Adjust the closing speed of the damper hinge to maximum fast.
 - ② Remove the cap from the spring hinge. Open the door by about 45° and insert the pre-set pin (stored in the cap) fully into the pre-set pin hole.
 - ③ Close the door to about 5° to 10° position. Loosen and remove the set screws (2 pcs.) with the hex key (M4).

*Contact Nitto Kohki or distributors near you to learn about a non-standard method of use and other questions.

2000 series

Installation procedure

- Set up the hinges after hanging the door.

*When hanging the door, align the notch on the shaft of the damper hinge with the hole in the door-side hinge body.

● Spring hinge

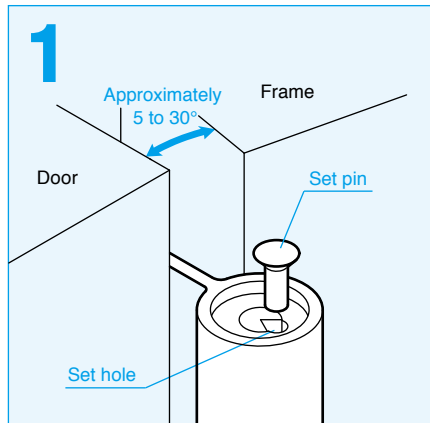

- Hang the door, then remove the cap. Open the door by about 5° to 30°.

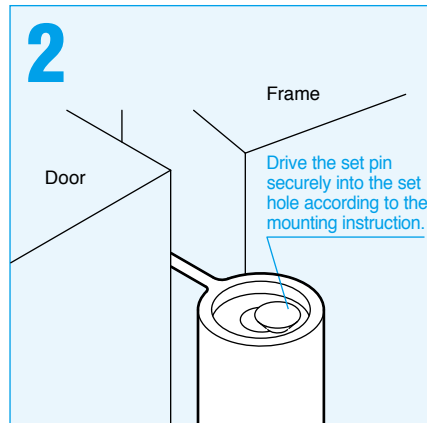

- Drive the supplied set pin securely into the installation hole according to the mounting instruction.

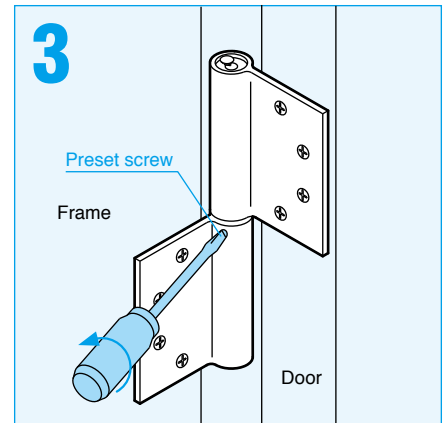

- Open the door by about 90°. Turn the preset screw counterclockwise, then make it stick out from the hinge surface.
- DO NOT operate the door before driving the set pin.
- After finishing the adjustment, place the cap back on the hinge.

● Damper hinge

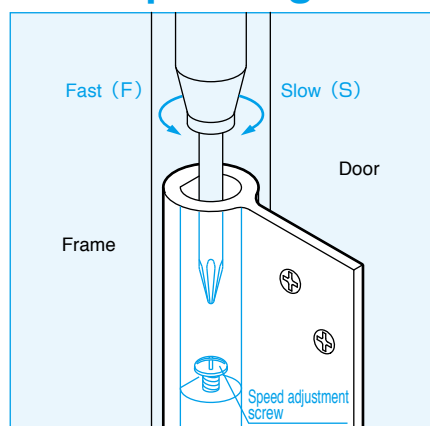

- Turn the speed adjustment screw according to the instructions given on the cap of the damper hinge, then adjust the door-closing speed. After finishing the adjustment, place the cap back on the hinge.

● Removal of the door

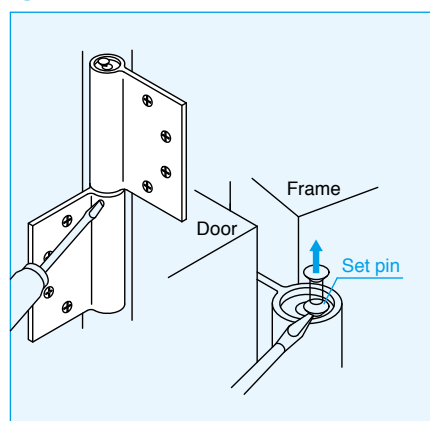

- ① Open the door by about 90°. Turn the preset screw clockwise. Make sure the preset screw is back to the original position as supplied from the factory.
- ② Close the door. The door should stop at about 15° position. Remove the spring pin as shown in the figure on the left.
- ③ The spring hinge becomes free and the door can be removed.

*Do not push or close the door before removing the spring pin. Failure to do so may cause an accident.

*It is dangerous to remove the fitting screw when the set pin is still wound.

*Be sure to release the spring force from the door before removing the door. Failure to do so may cause an accident.

100/200/NK series

Installation procedure

- Set up the hinges after hanging the door.

*When hanging the door, align the notch on the shaft of the damper hinge with the hole in the door-side hinge body.

Spring hinge

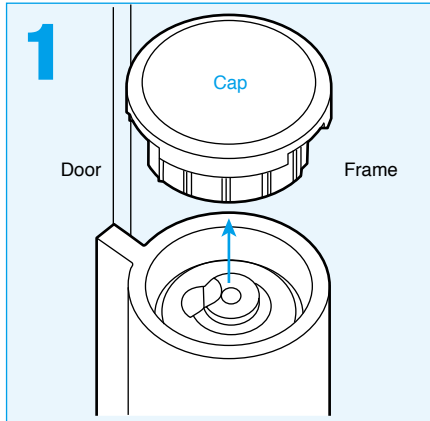

- Remove the cap.

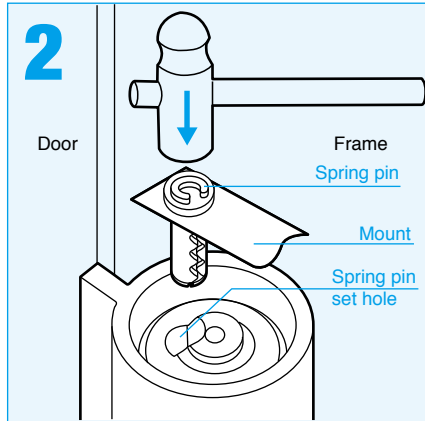

- Drive the spring pin.
- Open the door by about 10°. Align the spring pin with the installation hole and drive it securely according to the instructions given on the mount. Use the supplied spring pin only. Do not use any other screw as alternative.

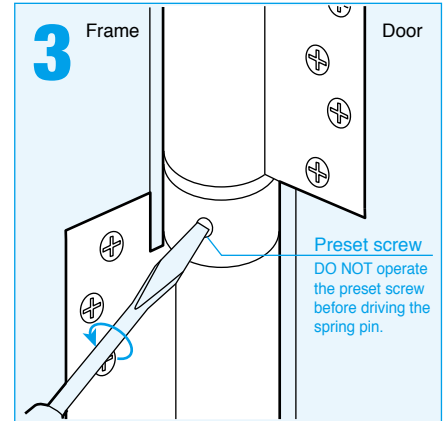

- Open the door by about 90°. Turn the preset screw counterclockwise by 3 to 4 turns, then make it stick out from the hinge surface by about 1mm. DO NOT operate the preset screw before driving the spring pin.

Damper hinge

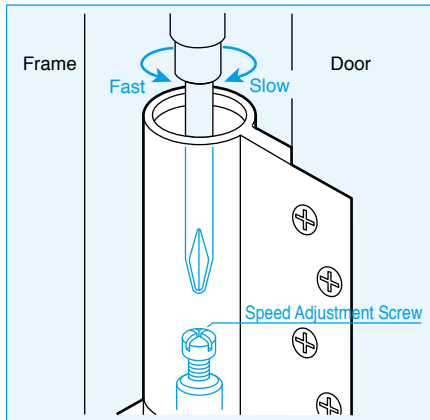

- Remove the cap. Turn the speed adjustment screw inside the damper hinge by screwdriver and adjust the door closing speed to the desired speed. Place the cap back to the hinge.

Removal of the door

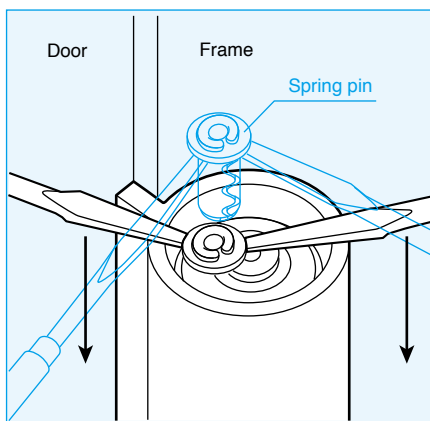

- ① Open the door by about 90°. Turn the preset screw clockwise by 3 to 4 turns. Make sure the preset screw is back to the original position as supplied from the factory.
- ② Close the door. The door should stop at about 5° position. Remove the spring pin as shown in the figure on the left. Carefully remove the door. (Do not push or close the door before removing the spring pin.)
- ③ When hanging the door again, make sure that the door is put back at the same angle as it was removed. (The angle to which the notch on the damper shaft is faced.)

700 series

Installation procedure

- Set up the hinges after hanging the door.

*When hanging the door, align the notch on the shaft of the damper hinge with the hole in the door-side hinge body.

Spring hinge

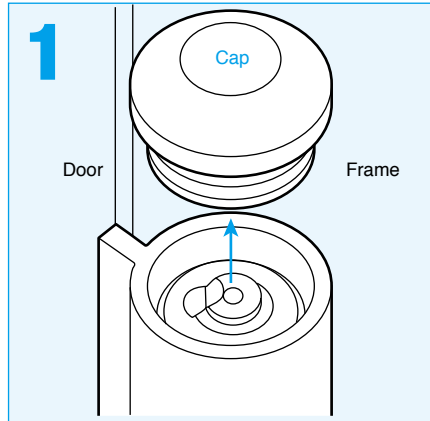

- Remove the cap.

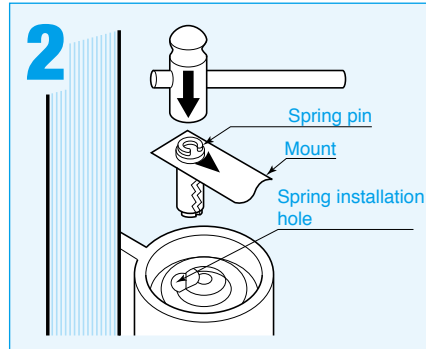

- Drive the spring pin.
- Open the door by about 10°. Align the spring pin with the installation hole and drive it securely according to the instructions given on the mount. Use the supplied spring pin only. Do not use any other screw as alternative.

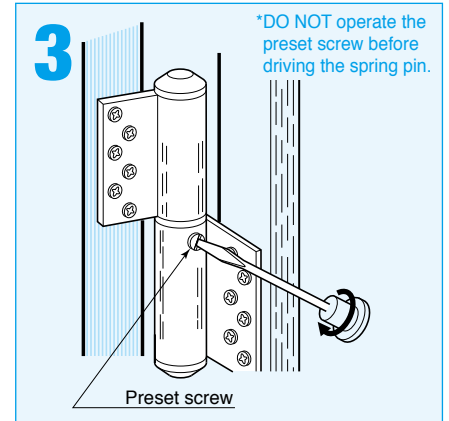

- Open the door by about 90°. Turn the preset screw counterclockwise by 3 to 4 turns, then make it stick out from the hinge surface by about 1mm. DO NOT operate the preset screw before driving the spring pin.

Damper hinge

How to hang the door

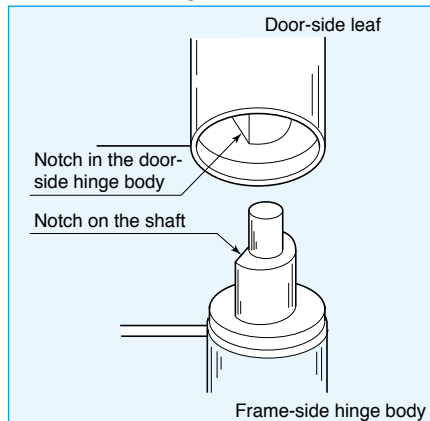

- Align the label on the cap with the notch on the shaft.
- Before installed, there is a gap between the door-side hinge body and the frame-side hinge body of the damper hinge. This gap will disappear as soon as once the door get hung, and the self-closing speed adjustment will become available. After hanging the door, confirm the gap is gone.
- Remove the cap. Turn the speed adjustment screw inside the damper hinge by screwdriver and adjust the door closing speed to the desired speed. Place the cap back to the hinge.

How to set the door-closing speed

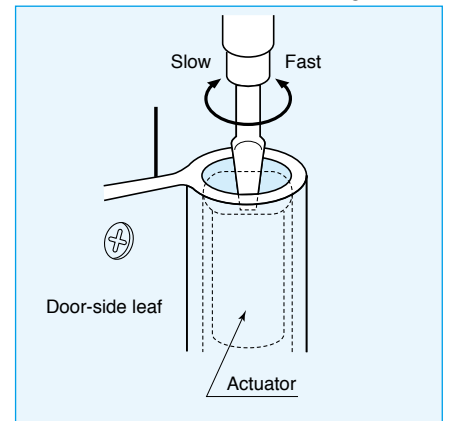

Removal of the door

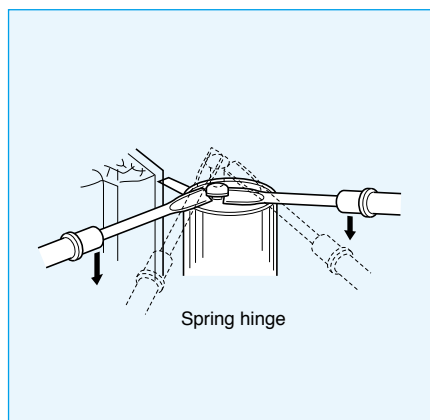

- ① Open the door by about 90°. Turn the preset screw clockwise by 3 to 4 turns. Make sure the preset screw is back to the original position as supplied from the factory.
- ② Close the door. The door should stop at about 5° position. Remove the spring pin as shown in the figure on the left. Carefully remove the door. (Do not push or close the door before removing the spring pin.)
- ③ When hanging the door again, make sure that the door is put back at the same angle as it was removed. (The angle to which the notch on the damper shaft is faced.)

*Contact Nitto Kohki or distributors near you to learn about a non-standard method of use and other questions.

*Should any hinge break, pull out the spring pin (refer to "Removal of the door") and turn the speed adjustment screw to the maximum fast. You can then use the hinge as a regular door hinge without self-closing/stop functions.

Installation procedure

- Set up the hinges after hanging the door.

*When hanging the door, align the notch on the shaft of the damper hinge with the hole in the door-side hinge body.

Spring hinge

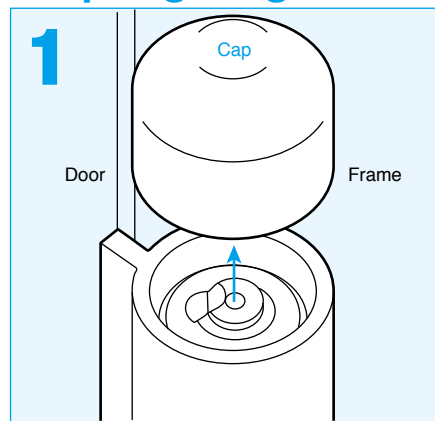

- Remove the cap.

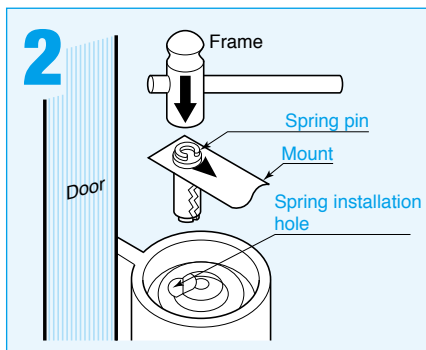

- Drive the spring pin.
- Open the door by about 10°. Align the spring pin with the installation hole and drive it securely according to the instructions given on the mount. Use the supplied spring pin only. Do not use any other screw as alternative.

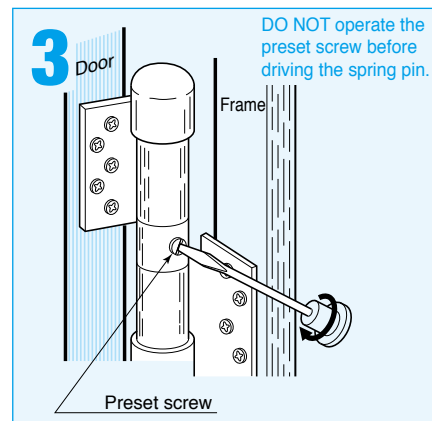

- Open the door by about 90°. Turn the preset screw counterclockwise by 3 to 4 turns, then make it stick out from the hinge surface by about 1mm. DO NOT operate the preset screw before driving the spring pin.

Damper hinge

How to hang the door

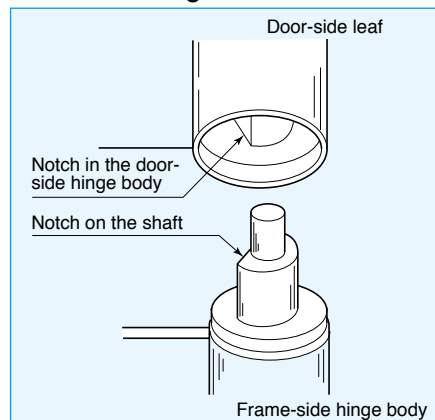

- Align the label on the cap with the notch on the shaft.
- Before installed, there is a gap between the door-side hinge body and the frame-side hinge body of the damper hinge. This gap will disappear as soon as once the door get hung, and the self-closing speed adjustment will become available. After hanging the door, confirm the gap is gone.

- Remove the cap. Turn the speed adjustment screw inside the damper hinge by screwdriver and adjust the door closing speed to the desired speed. Place the cap back to the hinge.

How to set the door-closing speed

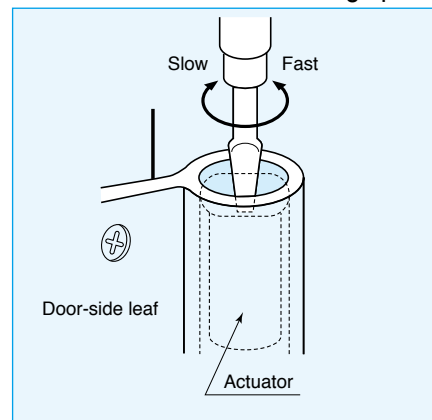

Removal of the door

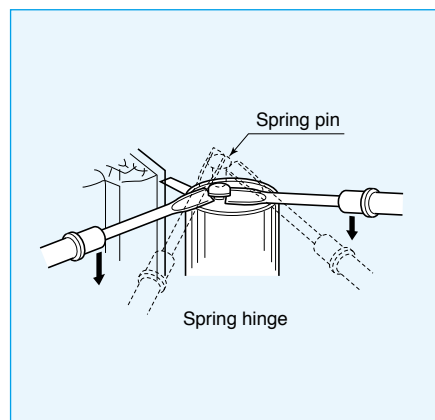

- ① Open the door by about 90°. Turn the preset screw clockwise by 3 to 4 turns. Make sure the preset screw is back to the original position as supplied from the factory.
- ② Close the door. The door should stop at about 5° position. Remove the spring pin as shown in the figure on the left. Carefully remove the door. (Do not push or close the door before removing the spring pin.)
- ③ When hanging the door again, make sure that the door is put back at the same angle as it was removed. (The angle to which the notch on the damper shaft is faced.)

*Contact Nitto Kohki or distributors near you to learn about a non-standard method of use and other questions.

*Should any hinge break, pull out the spring pin (refer to "Removal of the door") and turn the speed adjustment screw to the maximum fast. You can then use the hinge as a regular door hinge without self-closing/stop functions.

Auto Hinges

Mounting position for Flag Type Auto Hinges

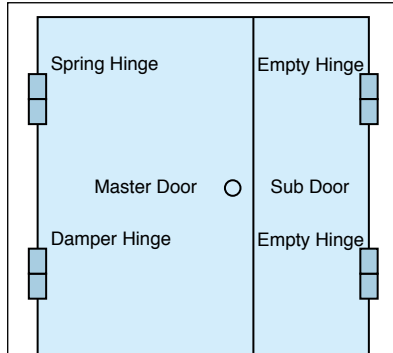

- In case the sub door does not require the self-closing function, you may use the empty hinges for the sub door so as to match the appearance with the master door.

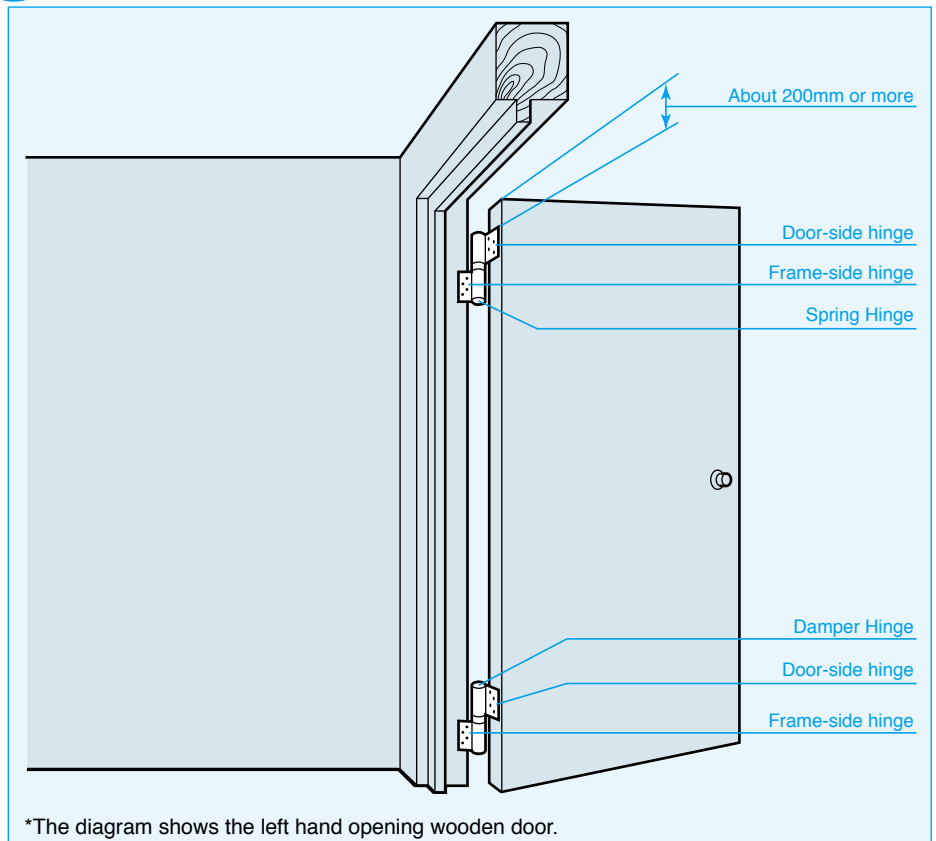

*The diagram shows the left hand opening wooden door.

Handling precautions

- Attach the hinge leaves in parallel with the door frame.

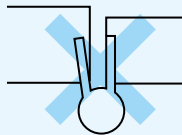

- Do not bend the hinge leaves.

- Do not hit or strike the hinge.

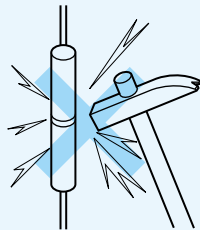

- Do not open the door more than 180°.

If the door is open more than 180°, it will damage the clutch mechanism and the door may stop opening/closing. To avoid this, always install a door stopper.

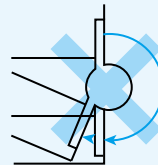

- Do not use the hinges in the place with high moisture or direct water splash. (Except PC and 700 series)water.

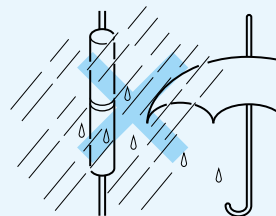

- Do not weld the hinge leaves.

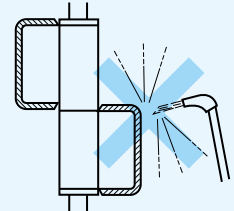

- Do not bend the hinge leaves. Also, do not use the hinges in the place exposed to extremely strong wind.

User-friendly technology

Door Closer

Auto Hinge & Sliding Door Closer

OTHER RELATED PRODUCTS

AUTO-HINGE

Center Hang Type

Concealed door hinge with self-closing function. Built into the door, offering clean exterior appearance. Excellent performance and durability, suitable for the fire proof doors.

- Concealed design, built into the bottom side of the door. Completely hidden inside the door, offering streamlined door appearance.
- Suitable for fire doors, smoke ventilations, air intake doors or regular swing doors.



Door Closer

Sliding Door Closer

Innovative solution adding self-closing feature to your sliding door. Also designed to assist in reducing the door opening resistance to achieve an easy and safe opening operation.

Horizontal model for bathroom
NSC-CB

Horizontal model
NSC-C

Incline model
DSC-C

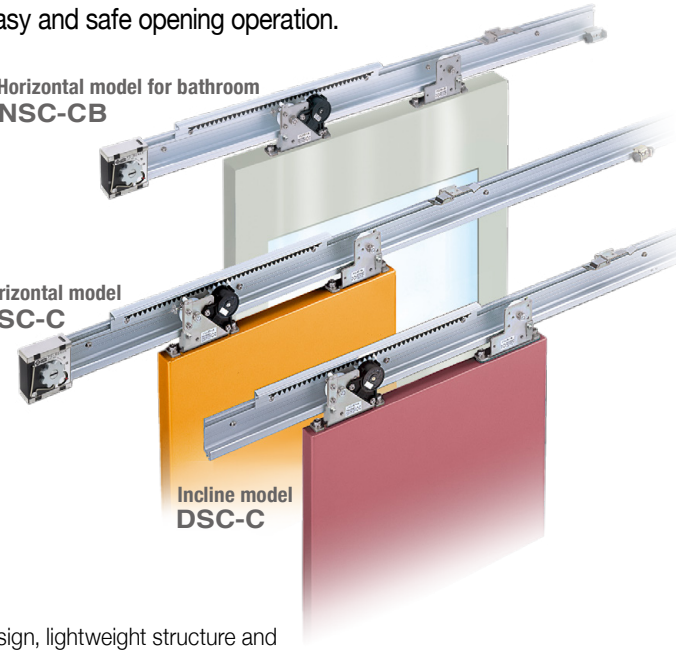

- Compact design, lightweight structure and long-life time are achieved by the unique endless viscosity resistance system (patented).
- Easy to adjust the door closing force and speed.

⚠ Safety precautions

- To avoid personal injury and other accidents, thoroughly read the precautions set forth in the "Instruction Manual" or "Catalog" and properly complete the installation and adjustment procedures before use.
- Ensure that the door closing speed is properly adjusted at all times. If it is set too fast, personal injury may be caused.

DISTRIBUTED BY

Focused on you

NITTO KOHKI CO., LTD.

DOOR CLOSERS Sales Dept :

8F, VORT Ueno, 4-7, Ueno 7-chome, Taito-ku,
Tokyo 110-0005, Japan
Tel : +81-3-5806-1030 Fax : +81-3-3843-5188
E-mail : Kentokyo@nitto-kohki.co.jp

Head Office:

9-4, Nakaikegami 2-chome, Ohta-ku,
Tokyo 146-8555, Japan

Web www.nitto-kohki.co.jp/e

