

CANTONI
MOTOR

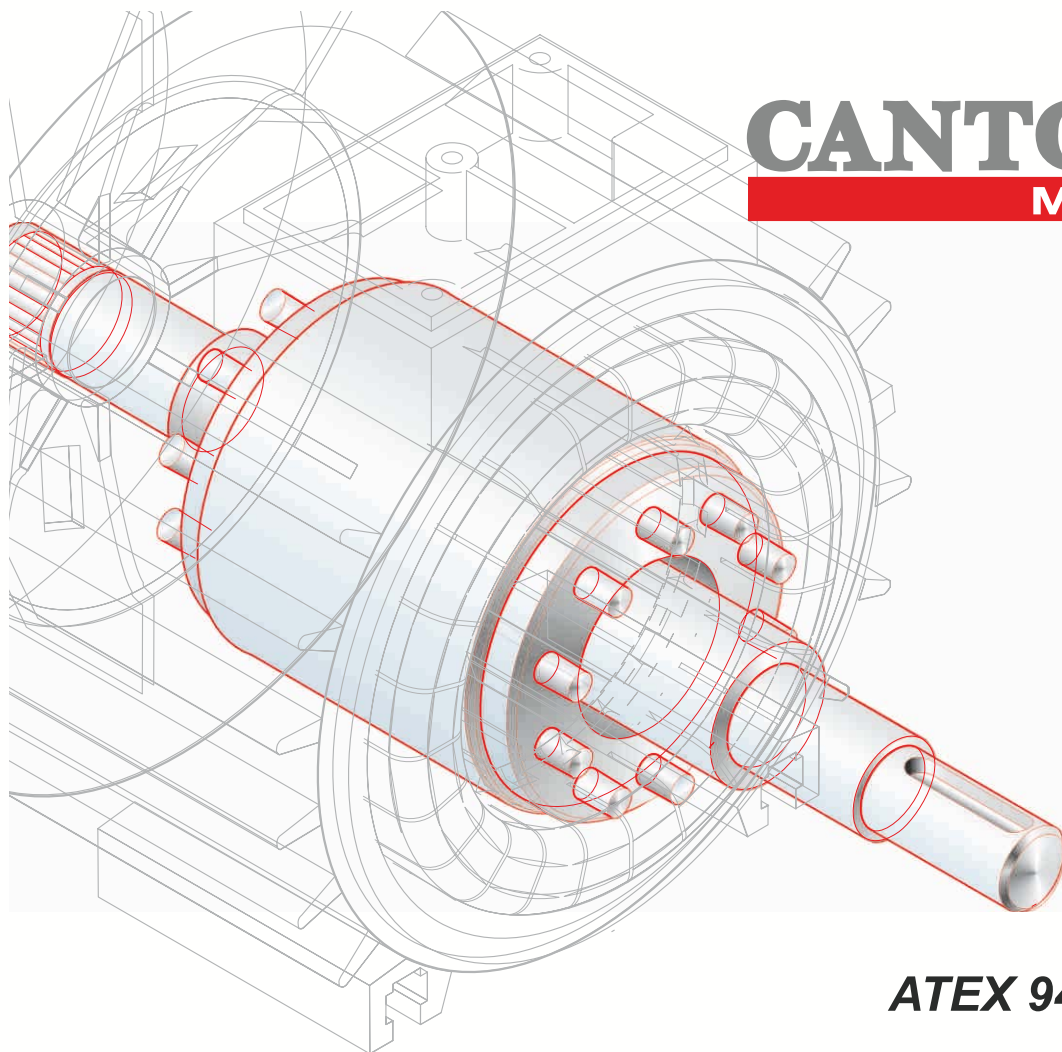

**Flame
Proof
Squirrel
Cage
Motors**

**according to
ATEX 94/9/EC Directive**

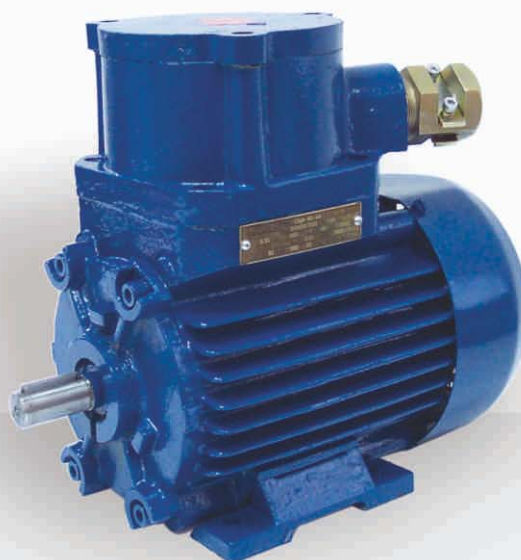

Cantoni[®]

GROUP

Cantoni Motor S.A.
3 Maja 28
43-400 Cieszyn, Poland
tel.: +48 33 813 87 00
fax: +48 33 813 87 01
motor@cantonigroup.com
www.cantonimotor.com

since 1950



since 1920
since 1878



since 1921



since 1954



The catalogue covers flame-proof motors intended for use in chemical industry.

The motors are adapted for operating in areas endangered by explosion, zone 1 and zone 2, category 2G, for use in potentially explosive atmospheres other than mines susceptible to fire-damp, for group IIA or IIB or IIB + H₂ (including hydrogen) or IIC.

The body of the motor is mechanically tough and does not allow to transfer the explosion outside the motor.

Temperature class for the motors is T5 or T4. It means that the maximum temperature of any part of the surface of the motor can not exceed +100°C.

Our motors are designed for long life and reliable operation.

IDENTIFICATION

Frame Size	ATEX Certificate	Flame-Proof Body Increased Safety Terminal Box	Type of Motor	Flame-Proof Body and Terminal Box	Type of Motor
80	KDB 04ATEX052X	II 2G Exde IIC T5 Gb	ECS(K,L,1)g 80	II 2G Exd IIB +H ₂ T5 Gb	CS(K,L,1)gb 80
90	KDB 04ATEX052X	II 2G Exde IIB +H ₂ T5 Gb	ECS(K,L,1)gb 90	II 2G Exd IIB +H ₂ T5 Gb	CS(K,L,1)gb 90
100	KDB 04ATEX052X	II 2G Exde IIB T5 Gb	ECS(K,L,1)gb 100	II 2G Exd IIB T5 Gb	CS(K,L,1)gb 100
112	KDB 04ATEX052X	II 2G Exde IIC T5 Gb	ECS(K,L,1)g 112	II 2G Exd IIC T5 Gb	CS(K,L,1)g 112
132	KDB 04ATEX052X	II 2G Exde IIC T5 Gb	ECS(K,L,1)g 132	II 2G Exd IIC T5 Gb	CS(K,L,1)g 132
160	KDB 04ATEX053X	II 2G Exde IIB T5 Gb	EcS(K,L)gb 160	II 2G Exd IIB T5 Gb	cS(K,L)gb 160
180	KDB 04ATEX053X	II 2G Exde IIC T5 Gb	EcS(K,L)g 180	II 2G Exd IIB T5 Gb	cS(K,L)gb 180
200	KDB 05ATEX183X	II 2G Exde IIC T5 Gb	EcS(K,L)g 200	II 2G Exd IIB T5 Gb	cS(K,L)gb 200
225	KDB 05ATEX183X	II 2G Exde IIB + H ₂ T5 Gb	EcS(K,L)gb 225	II 2G Exd IIB T5 Gb	cS(K,L)gb 225
250	KDB 05ATEX183X	II 2G Exde IIB + H ₂ T5 Gb	EcS(K,L)gb 250	II 2G Exd IIB T5 Gb	cS(K,L)gb 250
280	KDB 05ATEX183X	II 2G Exde IIB + H ₂ T5 Gb	EcS(K,L)gb 280	II 2G Exd IIB T5 Gb	cS(K,L)gb 280
315	KDB 04ATEX054X	II 2G Exde IIB T4 Gb	EcS(K,L)gb 315	II 2G Exd IIB T4 Gb	cS(K,L)gb 315

BEARINGS



Frame Size	3000 rpm		1500 rpm		1000 rpm		750 rpm	
	Drive End	Non Drive End	Drive End	Non Drive End	Drive End	Non Drive End	Drive End	Non Drive End
80	6204 2Z	6204 2Z	6204 2Z	6204 2Z	-	-	-	-
90	6205 2Z	6205 2Z	6205 2Z	6205 2Z	-	-	-	-
100	6206 2Z	6206 2Z	6206 2Z	6206 2Z	-	-	-	-
112	6306 2Z	6306 2Z	6306 2Z	6306 2Z	-	-	-	-
132	6308 2Z	6308 2Z	6308 2Z	6308 2Z	-	-	-	-
160	6309 2ZC3	6309 2ZC3	6309 2ZC3	6309 2ZC3	6309 2ZC3	6309 2ZC3	6309 2ZC3	6309 2ZC3
180	6311 2ZC3	6311 2ZC3	6311 2ZC3	6311 2ZC3	6311 2ZC3	6311 2ZC3	6311 2ZC3	6311 2ZC3
200	NU 312	6312 C3	NU 312	6312 C3	NU 312	6312 C3	NU 312	6312 C3
225	NU 313	6313 C3	NU 313	6313 C3	NU 313	6313 C3	NU 313	6313 C3
250	NU 315	6315 C3	NU 315	6315 C3	NU 315	6315 C3	NU 315	6315 C3
280	NU 315	6315 C3	NU 317	6317 C3	NU 317	6317 C3	NU 317	6317 C3
315	NU 315	6315 C3	NU 318	6318 C3	NU 318	6318 C3	NU 318	6318 C3

DESCRIPTION OF VERSION

- With ATEX Certificate, on request with GOST Certificate
- Continuous duty S1
- Voltage 400 V / 50 Hz, on request other voltage up to 750 V, frequency 60 Hz
- Ambient temperature -20°C +50°C (T5) Frame Size 80 - 132; on request -35°C
-20°C +40°C (T5) Frame Size 160 - 280; on request -30°C, -40°C, -50°C
-20°C +40°C (T4) Frame Size 315; on request -30°C, -40°C, -50°C
- According to standard 60079-0, 60079-1
- Insulation class F, on request class H
- Degree of protection IP 54 (80-132), IP 55 (160-315); on request IP 56, IP 65, IP 66



As part of our development programme, we reserve the right to alter or amend any of the specifications included in this catalogue without giving prior notice.

Totally Enclosed Motors
Insulation Class F

TECHNICAL DATA

Item	Frame Size	Rated Output		Rated Speed n_N [rpm]	Rated Torque T_N [Nm]	Efficiency η_N [%]	Power Factor $\cos \varphi_N$ [-]	Full load Current at 400V I_N [A]	Starting Torque Ratio T_L/T_N [-]	Starting Current Ratio I_L/I_N [-]	Breakdown Torque Ratio T_B/T_N [-]	Moment of Inertia J [kgm ²]	Weight (IMB3) m [kg]
		P_N [kW]	[HP]										
		2p=2 $n_s=3000$ rpm											
1.	802A	0,75	1	2770	2,6	75	0,86	1,7	2,4	4,9	3	0,0008	25,3
2.	802B	1,1	1,5	2785	3,8	79	0,86	2,3	3,2	6,2	3,2	0,001	26,6
3.	90S2	1,5	2	2845	5	79,1	0,82	3,3	2,9	5,5	3,1	0,0013	34,5
4.	90L2	2,2	3	2865	7,3	83,3	0,82	4,6	3,4	6,5	3,5	0,002	36,5
5.	100L2	3	4	2905	9,9	83,4	0,86	6	2,7	7,5	2,8	0,0048	48
6.	112M2	4	5,5	2875	13,3	85,4	0,90	7,5	2,1	6,2	2,3	0,0079	71
7.	132S2A	5,5	7,5	2920	18	87	0,88	10,4	2,4	7	3,2	0,015	96
8.	132S2B	7,5	10	2925	24,5	87,5	0,88	14,1	2,5	7,5	3,2	0,018	102
9.	160M2A	11	15	2925	36	88,5	0,89	20,2	2,1	5,7	2,5	0,04	150
10.	160M2B	15	20	2920	49	89,5	0,91	26,6	2,1	6	2,2	0,05	158
11.	160L2	18,5	25	2925	60	91,3	0,90	32,5	2,4	6,5	2,8	0,06	176
12.	180M2	22	30	2945	71	91,5	0,89	39	2,7	6,8	2,6	0,07	210
13.	200L2A	30	40	2960	97	92,9	0,89	52	1,9	6	2,3	0,15	285
14.	200L2B	37	50	2960	119	93,7	0,89	64	2,2	6,7	2,5	0,18	315
15.	225M2	45	60	2968	145	94,5	0,89	77	2,4	7	2,5	0,26	375
16.	250M2	55	75	2970	177	93,5	0,90	94	2	6,9	2	0,36	434
17.	280S2	75	100	2977	241	94	0,90	128	2,1	7,5	3,3	0,76	580
18.	280M2	90	125	2970	289	94,7	0,91	151	2	7	3,2	0,87	620
19.	315S2	110	150	2977	353	95,1	0,91	183	2,0	8,7	2,8	0,91	755
20.	315M2A	132	175	2975	424	95	0,91	220	2,1	8,5	2,8	0,98	795
21.	315M2B	160	220	2975	514	95,9	0,91	265	1,9	7,9	2,7	1,2	855
2p=4 $n_s=1500$ rpm													
22.	804A	0,55	0,75	1400	3,8	72,0	0,62	1,8	3,0	4,6	3	0,0016	25,3
23.	804B	0,75	1	1405	5,1	74	0,64	2,3	3,2	5,0	3,3	0,0019	26,7
24.	90S4	1,1	1,5	1405	7,5	75	0,8	2,6	2,1	4,5	2,6	0,0023	34,5
25.	90L4	1,5	2	1410	10,2	78	0,79	3,5	2,5	4,9	2,8	0,0028	36,5
26.	100L4A	2,2	3	1425	14,7	81	0,81	4,8	2,5	5,9	2,8	0,0058	47
27.	100L4B	3	4	1415	20,2	81	0,81	6,6	2,6	5,8	2,7	0,0065	50
28.	112M4	4	5,5	1435	26,6	85,1	0,84	8,1	2,6	6,3	3	0,0118	71
29.	132S4	5,5	7,5	1450	36,2	85,8	0,84	11	2,2	6,9	3,1	0,029	97
30.	132M4	7,5	10	1450	49,4	87	0,85	14,6	2,2	6,7	3,1	0,035	105
31.	160M4	11	15	1463	72	89,5	0,84	21,1	2,5	7,5	2,9	0,06	150
32.	160L4	15	20	1460	98	89,8	0,86	28	2,5	7,9	3,2	0,08	172
33.	180M4	18,5	25	1465	121	90,8	0,9	32,5	2,3	6,9	2,9	0,11	205
34.	180L4	22	30	1465	143	91,5	0,9	38,6	2,5	7,2	2,9	0,13	225
35.	200L4	30	40	1472	195	92,5	0,88	53	2,9	7,1	2,5	0,31	310
36.	225S4	37	50	1475	240	92,6	0,88	66	2,1	6,3	2,2	0,44	350
37.	225M4	45	60	1480	290	94	0,88	79	2,4	7	2,3	0,53	390
38.	250M4	55	75	1483	354	93,5	0,91	93	2,4	7,3	2,6	0,79	465
39.	280S4	75	100	1485	482	94,2	0,9	128	2,5	7,3	2,5	1,37	630
40.	280M4	90	125	1485	579	94,8	0,91	151	2,6	7,3	2,6	1,63	670
41.	315S4	110	150	1480	710	94,2	0,92	183	2,3	6,9	2,2	1,67	785
42.	315M4A	132	175	1487	848	94,9	0,90	223	2,3	7,6	2,5	1,84	825
43.	315M4B	160	220	1489	1026	95,4	0,86	281	2,7	8,5	2,4	2,27	865

Totally Enclosed Motors
Insulation class F

Item	Frame Size	Rated Output		Rated Speed	Rated Torque	Efficiency	Power Factor	Full load Current at 400V	Starting Torque Ratio	Starting Current Ratio	Breakdown Torque Ratio	Moment of Inertia	Weight (IMB3)
		P_N [kW]	[HP]										
2p=6 $n_s=1000$ rpm													
44.	100L6	1,5	2,0	962	14,9	81,4	0,74	3,6	1,9	4,6	2,3	0,009	47
45.	112M6	2,2	2,9	963	22	86,2	0,73	5,0	2,3	6,1	2,8	0,0177	75
46.	160M6	7,5	10	962	74	87,5	0,81	15,3	2,2	6,4	3	0,07	146
47.	160L6	11	15	960	109	88,2	0,82	22	2,2	6,7	2,8	0,1	173
48.	180L6	15	20	973	147	89	0,85	28,6	2,4	5,6	2,4	0,19	210
49.	200L6A	18,5	25	980	180	90,5	0,86	34,5	2,5	6,8	2,4	0,41	290
50.	200L6B	22	30	981	214	90,5	0,88	40	2,4	6,9	2,2	0,47	305
51.	225M6	30	40	982	292	91,9	0,88	54	2,1	6,3	2,2	0,76	365
52.	250M6	37	50	985	359	92,5	0,89	65	2,6	6,8	2,3	1,23	458
53.	280S6	45	60	985	436	93	0,87	80	2	6,5	2,3	1,35	555
54.	280M6	55	75	985	533	93,5	0,89	95	2,2	6,2	2,2	1,61	600
55.	315S6	75	100	985	727	93,5	0,89	130	2,3	6,6	2,2	2,16	785
56.	315M6A	90	125	984	873	93,7	0,88	158	2,5	6,8	2	2,29	815
57.	315M6B	110	150	985	1066	94,2	0,89	189	2,3	7,2	2,1	2,86	900
2p=8 $n_s=750$ rpm													
58.	160M8A	4	5,5	710	54	81	0,75	9,5	2,1	5,1	2,7	0,06	132
59.	160M8B	5,5	7,5	705	74,5	82,5	0,75	12,8	2,5	5,5	3,1	0,08	142
60.	160L8	7,5	10	708	101	83,5	0,78	16,6	2,7	5,7	3	0,1	162
61.	180L8	11	15	730	144	88,5	0,76	23,6	1,9	5,5	2,5	0,19	208
62.	200L8	15	20	733	195	89,5	0,83	29,1	2,2	5,5	2,1	0,45	290
63.	225S8	18,5	25	735	240	89,5	0,81	37	2	5,6	2	0,58	320
64.	225M8	22	30	735	286	90,4	0,8	44	2	5,2	1,8	0,68	350
65.	250M8	30	40	738	388	91,5	0,84	56	2,5	6,3	2,1	1,27	455
66.	280S8	37	50	737	479	92,8	0,83	69	2	5,3	1,8	1,47	575
67.	280M8	45	60	737	583	92,5	0,84	84	2,1	5,4	2	1,8	635
68.	315S8	55	75	735	715	92,7	0,81	106	2	5,3	1,9	2,16	785
69.	315M8A	75	100	737	972	93,2	0,82	142	2,5	6,2	1,9	2,29	810
70.	315M8B	90	125	737	1166	93,2	0,82	170	2,4	6,5	1,9	2,86	890

TECHNICAL DATA

FOOT MOUNTED MOTORS - IM B3

DIMENSION DRAWINGS

.CSg.

80 ÷ 132

- IM 1001
- IM 1011
- IM 1031
- IM 1051
- IM 1061
- IM 1071

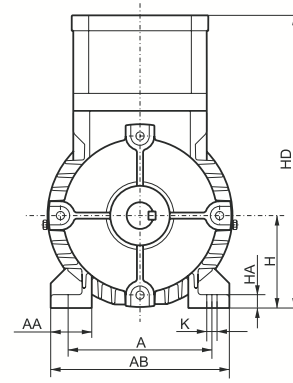
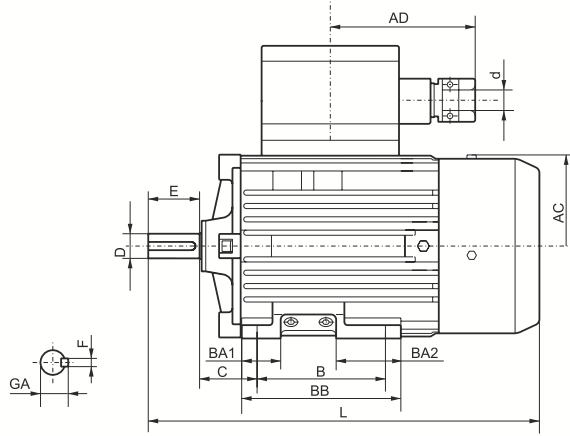

.cSg.

160 ÷ 180

- IM 1001
- IM 1011
- IM 1031
- IM 1051
- IM 1061
- IM 1071

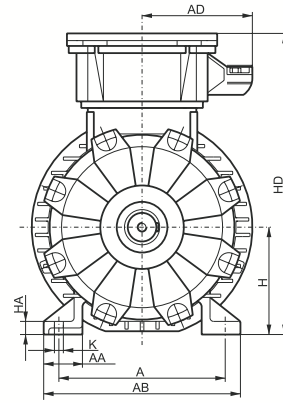
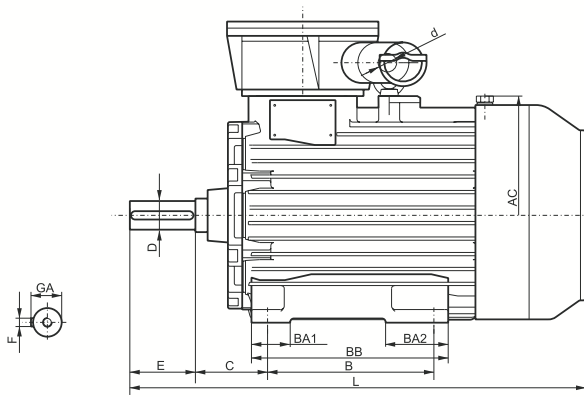

.cSg.

200 ÷ 315

- IM 1001
- IM 1011
- IM 1031
- IM 1051
- IM 1061
- IM 1071

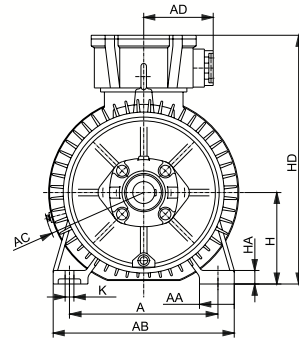
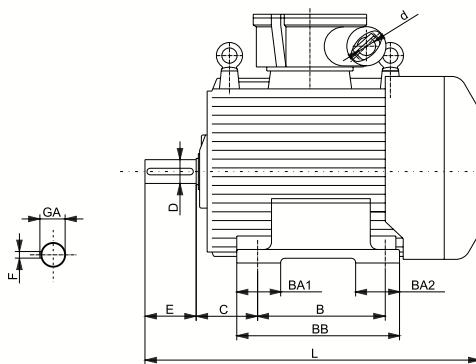

Frame	A	B	C	D	E	F h9	GA	H	HA	K	AA	AB	AC	AD	BA1	BA2	BB	HD	L	d
.CSg. 80.	125	100	50	19j6	40	6	21,5	80	12	10	40	165	190	145	38	38	130	274	310	8-17
.CSg. 90S.	140	100	56	24j6	50	8	27	90	13	10	40	174	190	145	38	63	155	291	380	8-17
.Csg. 90L.	140	125	56	24j6	50	8	27	90	13	10	40	174	190	145	48	48	170	311	430	8-17
.CSg.100L.	160	140	63	28j6	60	8	31	100	14	12	45	200	211	145	48	48	170	311	430	8-17
.Csg 112M.	190	140	70	28j6	60	8	31	112	14	12	54	230	240	150	50	50	174	376	475	8-17
.CSg 132S.	216	140	89	38k6	80	10	41	132	16	12	56	270	286	150	50	88	218	409	570	8-17
.Csg 132M.	216	178	89	38k6	80	10	41	132	16	12	56	270	286	150	50	88	218	409	570	8-17
.cSg. 160 M.	254	210	108	42k6	110	12	45	160	22	15	60	300	360	185	60	60	256	475	670	20-25
.cSg. 160 L.	254	254	108	42k6	110	12	45	160	22	15	60	300	360	185	60	60	300	475	710	20-25
.cSg. 180 M.	279	241	121	48k6	110	14	51,5	180	22	15	65	330	400	185	65	105	330	515	765	26-31
.cSg. 180 L.	279	279	121	48k6	110	14	51,5	180	22	15	65	330	400	185	65	105	330	515	765	26-31
.cSg. 200L.	318	305	133	55m6	110	16	59	200	32	19	80	400	465	190	105	105	388	600	810	32-37
.cSg. 225S.	356	286	149	60m6	140	18	64	225	34	19	85	445	510	190	115	120	385	645	860	32-37
.cSg. 225M2	356	311	149	55m6	110	16	59	225	34	19	85	445	510	190	115	120	385	645	830	32-37
.cSg. 225M4-8	356	311	149	60m6	140	18	64	225	34	19	85	445	510	190	115	120	385	645	860	32-37
.cSg. 250M2	406	349	168	60m6	140	18	64	250	37	24	95	495	550	190	120	120	445	690	915	38-43
.cSg. 250M4-8	406	349	168	65m6	140	18	69	250	37	24	95	495	550	190	120	120	445	690	915	38-43
.cSg. 280S2	457	368	190	65m6	140	18	69	280	40	24	100	560	620	190	140	170	500	765	1060	44-49
.cSg. 280S4-8	457	368	190	75m6	140	20	79,5	280	40	24	100	560	620	190	140	170	500	765	1060	44-49
.cSg. 280M2	457	419	190	65m6	140	18	69	280	40	24	100	560	620	190	140	170	500	765	1060	44-49
.cSg. 280M4	457	419	190	75m6	140	20	79,5	280	40	24	100	560	620	190	140	170	500	765	1060	44-49
.cSg. 315S2	508	406	216	65m6	140	18	69	315	46	28	105	610	625	190	140	185	550	815	1210	52-55
.cSg. 315S4-8	508	406	216	80m6	170	22	85	315	46	28	105	610	625	190	140	185	550	815	1240	52-55
.cSg. 315M2	508	457	216	65m6	140	18	69	315	46	28	105	610	625	190	140	185	550	815	1210	52-55
.cSg. 315M4-8	508	457	216	80m6	170	22	85	315	46	28	105	610	625	190	140	185	550	815	1240	52-55

FOOT/FLANGE MOUNTED MOTORS - IM B35
FOOT/FLANGE MOUNTED MOTORS - IM B34

.CSLg.

80 ÷ 132

- IM 2001
- IM 2011
- IM 2031
- IM 2051
- IM 2061
- IM 2071

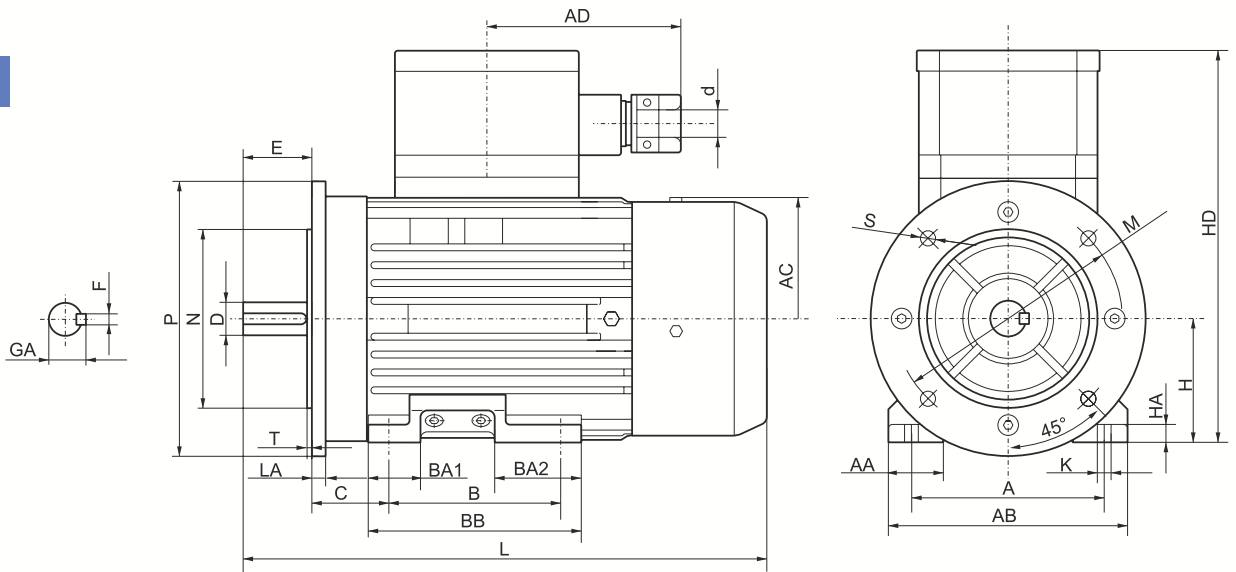

.CSL1g.

80 ÷ 132

- IM 2101
- IM 2111
- IM 2131
- IM 2151
- IM 2161
- IM 2171

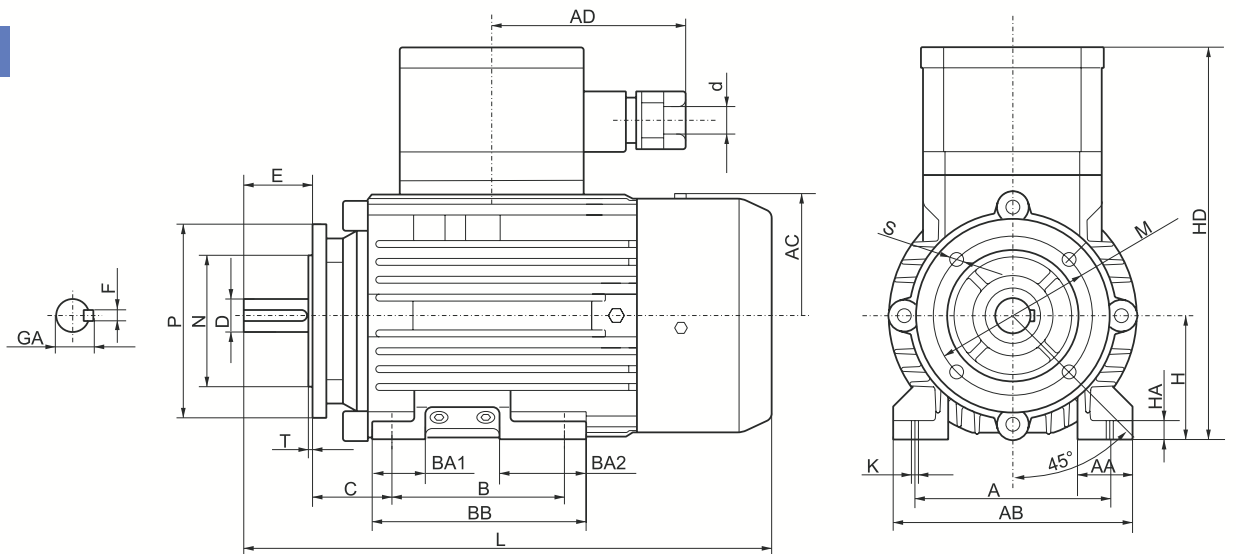

Frame	Fl.	A	B	C	D	E	Fh9	GA	H-0,5	HA	LA	M	Nj6	P	φ	no.	T	K	AA	AB	AC	AD	BA1	BA2	BB	HD	L	d
.CSLg. 80.	B5	125	100	50	19j6	40	6	21,5	80	12	15	165	130	200	12	4	3,5	10	40	165	190	145	38	38	130	274	310	8-17
.CSL1g. 80.	B14	125	100	50	19j6	40	6	21,5	80	12	15	100	80	120	M6	4	3	10	40	165	190	145	38	38	130	274	310	8-17
.CSLg. 90S.	B5	140	100	56	24j6	50	8	27	90	13	10	165	130	200	12	4	3,5	10	40	174	190	150	38	63	155	291	380	8-17
.CSL1g. 90S.	B14	140	100	56	24j6	50	8	27	90	13	10	115	95	140	M8	4	3	10	40	174	190	150	38	63	155	291	380	8-17
.CSLg. 90L.	B5	140	125	56	24j6	50	8	27	90	13	10	165	130	200	12	4	3,5	10	40	174	190	150	38	63	155	291	380	8-17
.CSL1g. 90L.	B14	140	125	56	24j6	50	8	27	90	13	10	115	95	140	M8	4	3	10	40	174	190	150	38	63	155	291	380	8-17
.CSLg. 100L.	B5	160	140	63	28j6	60	8	31	100	14	11	215	180	250	15	4	4	12	45	200	211	143	48	48	170	311	430	8-17
.CSL1g. 100L.	B14	160	140	63	28j6	60	8	31	100	14	11	130	110	160	M8	4	3,5	12	45	200	211	143	48	48	170	311	430	8-17
.CSLg. 112M.	B5	190	140	70	28j6	60	8	31	112	14	12	215	180	250	15	4	4	12	54	230	240	150	50	50	174	376	475	8-17
.CSL1g. 112M.	B14	190	140	70	28j6	60	8	31	112	14	12	130	110	160	M8	4	3,5	12	54	230	240	150	50	50	174	376	475	8-17
.CSLg. 132S.	B5	216	140	89	38k6	80	10	41	132	16	15	265	230	300	14,5	4	4	12	56	270	286	150	50	88	218	409	570	8-17
.CSL1g. 132S.	B14	216	140	89	38k6	80	10	41	132	16	15	165	130	200	M10	4	3,5	12	56	270	286	150	50	88	218	409	570	8-17
.CSLg. 132M.	B5	216	178	89	38k6	80	10	41	132	16	15	265	230	300	14,5	4	4	12	56	270	286	150	50	88	218	409	570	8-17
.CSL1g. 132M.	B14	216	178	89	38k6	80	10	41	132	16	15	165	130	200	M10	4	3,5	12	56	270	286	150	50	88	218	409	570	8-17

DIMENSION DRAWINGS

FOOT/FLANGE MOUNTED MOTORS - IM B35

.cSLg.

160 ÷ 180

- IM 2001
- IM 2011
- IM 2031
- IM 2051
- IM 2061
- IM 2071

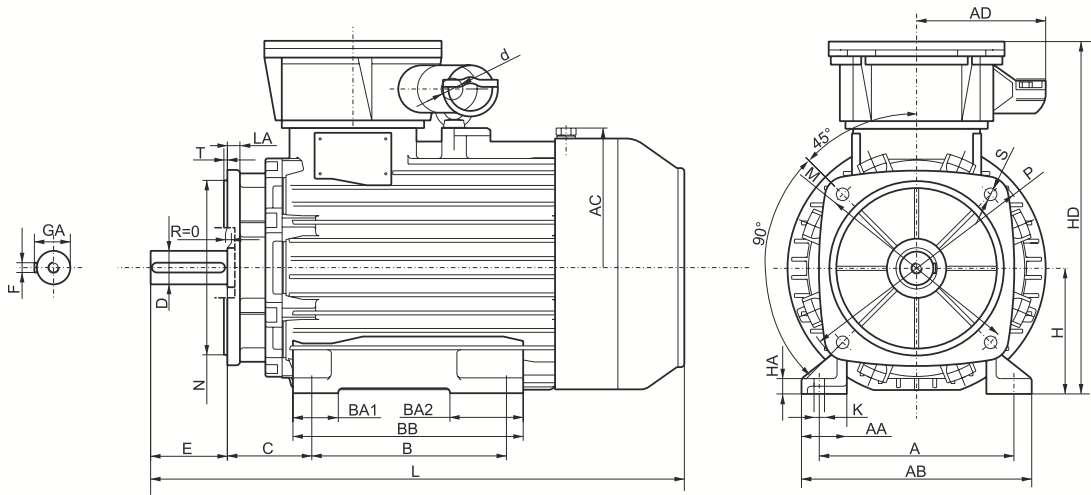

.cSLg.

200 ÷ 315

- IM 2001
- IM 2011
- IM 2031
- IM 2051
- IM 2061
- IM 2071

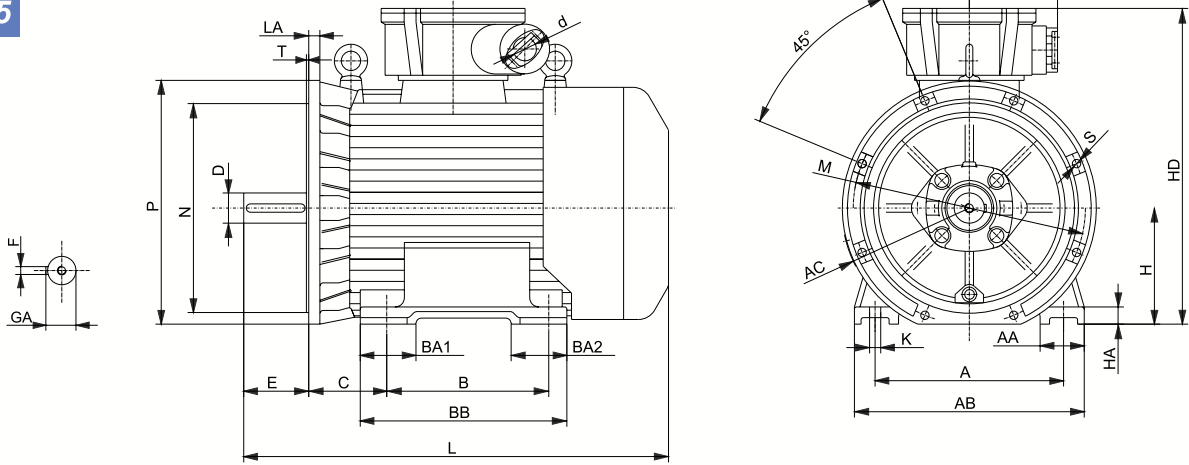

DIMENSION DRAWINGS

Frame	A	B	C	D	E	Fh9	GA	H-0.5	HA	K	LA	M	N	P	Φ	no.	T	AA	AB	AC	AD	BA1	BA2	BB	HD	L	d
.cSLg. 160M.	254	210	108	42k6	110	12	45	160	22	15	17	300	250j6	350	18	4	5	60	300	360	185	60	60	256	475	670	20-25
.cSLg. 160L.	254	254	108	42k6	110	12	45	160	22	15	17	300	250j6	350	18	4	5	60	300	360	185	60	60	300	475	710	20-25
.cSLg. 180M.	279	241	121	48k6	110	14	51,5	180	22	15	18	300	250j6	350	18	4	5	65	330	400	185	65	105	330	515	765	26-31
.cSLg. 180L.	279	279	121	48k6	110	14	51,5	180	22	15	18	300	250j6	350	18	4	5	65	330	400	185	65	105	330	515	765	26-31
.cSLg. 200L.	318	305	133	55m6	110	16	59	200	32	19	21	350	300j6	400	18	4	5	80	400	465	190	105	105	388	600	810	32-37
.cSLg. 225S.	356	286	149	60m6	140	18	64	225	34	19	22	400	350j6	450	18	8	5	85	445	510	190	115	120	385	645	860	32-37
.cSLg. 225M2	356	311	149	55m6	110	16	59	225	34	19	22	400	350j6	450	18	8	5	85	445	510	190	115	120	385	645	830	32-37
.cSLg. 225M.	356	311	149	60m6	140	18	64	225	34	19	22	400	350j6	450	18	8	5	85	445	510	190	115	120	385	645	860	32-37
.cSLg. 250M2	406	349	168	60m6	140	18	64	250	37	24	24	500	450j6	550	18	8	5	95	495	550	190	120	120	445	690	915	38-43
.cSLg. 250M.	406	349	168	65m6	140	18	69	250	37	24	24	500	450j6	550	18	8	5	95	495	550	190	120	120	445	690	915	38-43
.cSLg. 280S2	457	368	190	65m6	140	18	69	280	40	24	25	500	450j6	550	18	8	5	100	560	620	190	140	170	500	765	1060	44-49
.cSLg. 280S.	457	368	190	75m6	140	20	79,5	280	40	24	25	500	450j6	550	18	8	5	100	560	620	190	140	170	500	765	1060	44-49
.cSLg. 280M2	457	419	190	65m6	140	18	69	280	40	24	25	500	450j6	550	18	8	5	100	560	620	190	140	170	500	765	1060	44-49
.cSLg. 280M4	457	419	190	75m6	140	20	79,5	280	40	24	25	500	450j6	550	18	8	5	100	560	620	190	140	170	500	765	1060	44-49
.cSLg. 315S2	508	406	216	65m6	140	18	69	315	46	28	26	600	550js6	660	22	8	6	105	610	625	190	140	185	550	815	1210	52-55
.cSLg. 315S.	508	406	216	80m6	170	22	85	315	46	28	26	600	550js6	660	22	8	6	105	610	625	190	140	185	550	815	1240	52-55
.cSLg. 315M2	508	457	216	65m6	140	18	69	315	46	28	26	600	550js6	660	22	8	6	105	610	625	190	140	185	550	815	1210	52-55
.cSLg. 315M.	508	457	216	80m6	170	22	85	315	46	28	26	600	550js6	660	22	8	6	105	610	625	190	140	185	550	815	1240	52-55

FLANGE MOUNTED MOTORS - IM B5

.cSKg.

160 ÷ 180

- IM 3001
- IM 3011
- IM 3031

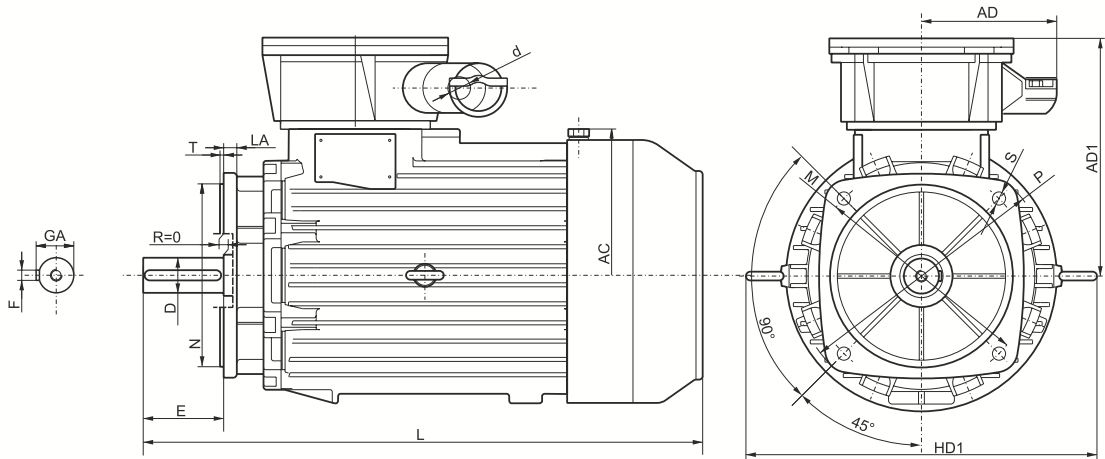

.cSKg.

200 ÷ 315

- IM 4001
- IM 4011
- IM 4031
- IM 3001
- IM 3011
- IM 3031

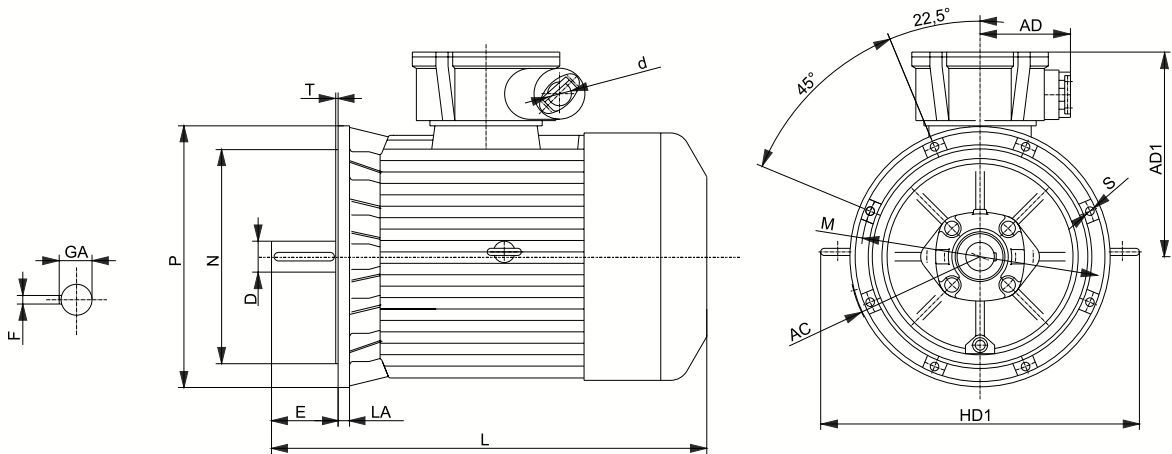

Frame	D	E	Fh9	GA	LA	M	N	P	Φ	S	T	AC	AD	AD1	HD1	L	d
									no.								
.cSKg. 160M.	42k6	110	12	45	17	300	250j6	350	18	4	5	360	185	315	440	670	20-25
.cSKg. 160L.	42k6	110	12	45	17	300	250j6	350	18	4	5	360	185	315	440	710	20-25
.cSKg. 180M.	48k6	110	14	51,5	18	300	250j6	350	18	4	5	400	185	335	480	765	26-31
.cSKg. 180L.	48k6	110	14	51,5	18	300	250j6	350	18	4	5	400	185	335	480	765	26-31
.cSKg. 200L.	55m6	110	16	59	21	350	300j6	400	18	4	5	465	190	400	560	810	32-37
.cSKg. 225S.	60m6	140	18	64	22	400	350j6	450	18	8	5	510	190	420	610	860	32-37
.cSKg. 225M2	55m6	110	16	59	22	400	350j6	450	18	8	5	510	190	420	610	830	32-37
.cSKg. 225M.	60m6	140	18	64	22	400	350j6	450	18	8	5	510	190	420	610	860	32-37
.cSKg. 250M2	60m6	140	18	64	24	500	450j6	550	18	8	5	550	190	440	670	915	38-43
.cSKg. 250M.	65m6	140	18	69	24	500	450j6	550	18	8	5	550	190	440	670	915	38-43
.cSKg. 280S2	65m6	140	18	69	25	500	450j6	550	18	8	5	620	190	485	770	1060	44-49
.cSKg. 280S.	75m6	140	20	79,5	25	500	450j6	550	18	8	5	620	190	485	770	1060	44-49
.cSKg. 280M2	65m6	140	18	69	25	500	450j6	550	18	8	5	620	190	485	770	1060	44-49
.cSKg. 280M4	75m6	140	20	79,5	25	500	450j6	550	18	8	5	620	190	485	770	1060	44-49
.cSKg. 315S2	65m6	140	18	69	26	600	550js6	660	22	8	6	625	190	500	770	1210	52-55
.cSKg. 315S.	80m6	170	22	85	26	600	550js6	660	22	8	6	625	190	500	770	1240	52-55
.cSKg. 315M2	65m6	140	18	69	26	600	550js6	660	22	8	6	625	190	500	770	1210	52-55
.cSKg. 315M.	80m6	170	22	85	26	600	550js6	660	22	8	6	625	190	500	770	1240	52-55

DIMENSION DRAWINGS

FLANGE MOUNTED MOTORS - IM B5
FLANGE MOUNTED MOTORS - IM B14

DIMENSION DRAWINGS

.CSKg.

80 ÷ 132

IM 3001
 IM 3011
 IM 3031

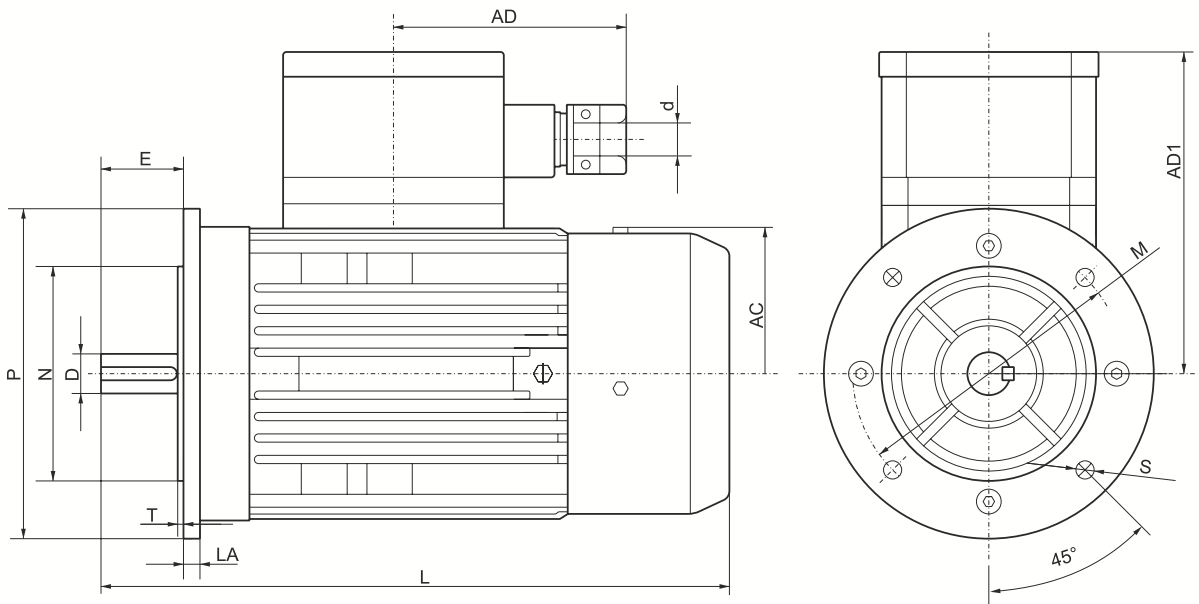
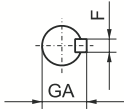

.CSK1g.

80 ÷ 132

IM 3601
 IM 3611
 IM 3631

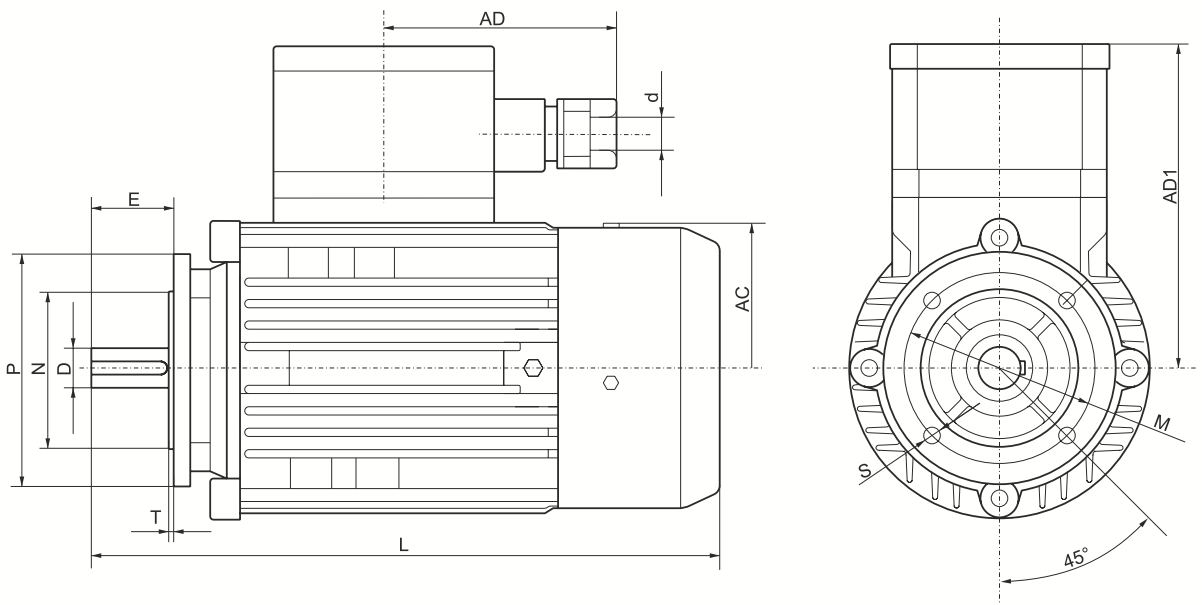
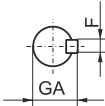

Frame	Fl.	D	E	Fh9	GA	LA	M	Nj6	P	Φ	S no.	T	AC	AD	AD1	L	d
.CSKg. 80.	B5	19j6	40	6	21,5	15	165	130	200	12	4	3,5	190	145	194	310	8-17
.CSK1g 80.	B14	19j6	40	6	21,5	15	100	80	120	M6	4	3	190	145	194	310	8-17
.CSKg. 90S.	B5	24j6	50	8	27	10	165	130	200	12	4	3,5	190	150	201	381	8-17
.CSK1g. 90S.	B14	24j6	50	8	27	10	115	95	140	M8	4	3	190	150	201	381	8-17
.CSKg. 90L.	B5	24j6	50	8	27	10	165	130	200	12	4	3,5	190	150	201	381	8-17
.CSK1g. 90L.	B14	24j6	50	8	27	10	115	95	140	M8	4	3	190	150	201	381	8-17
.CSKg. 100L.	B5	28j6	60	8	31	11	215	180	250	15	4	4	211	143	211	430	8-17
.CSK1g. 100L.	B14	28j6	60	8	31	11	130	110	160	M8	4	3,5	211	143	211	430	8-17
.CSKg 112M.	B5	28j6	60	8	31	12	215	180	250	15	4	4	240	150	264	470	8-17
.CSK1g 112M.	B14	28j6	60	8	31	12	130	110	160	M8	4	3,5	240	150	264	470	8-17
.CSKg 132S.	B5	38k6	80	10	41	15	265	230	300	14,5	4	4	286	150	277	570	8-17
.CSK1g 132S.	B14	38k6	80	10	41	15	165	130	200	M10	4	3,5	286	150	277	570	8-17
.CSKg 132M.	B5	38k6	80	10	41	15	265	230	300	14,5	4	4	286	150	277	570	8-17
.CSK1g 132M.	B14	38k6	80	10	41	15	165	130	200	M10	4	3,5	286	150	277	570	8-17



CANTONI MOTOR S.A.
3 Maja 28
43-400 Cieszyn, Poland
tel.: +48 33 813 87 00
fax: +48 33 813 87 01
motor@cantonigroup.com
www.cantonimotor.com

10/FP-ENVA