

GEAR

Nissei High Precision Gears

NISSEI CORPORATION'S QUALITY

We're always your best choice

Top class performance!



Three reasons why Nissei is chosen

1 Compact design with our original technique HRH

2 High precision gear grinded with CBN whetstone machine

3 High quality and mass production

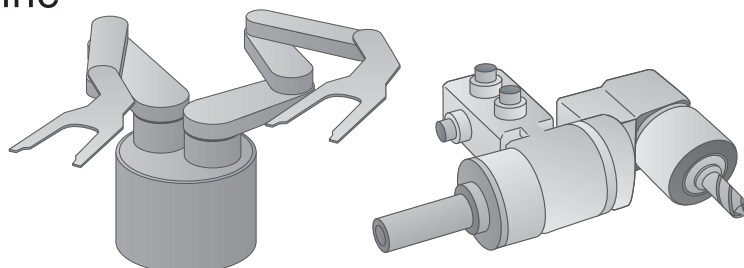
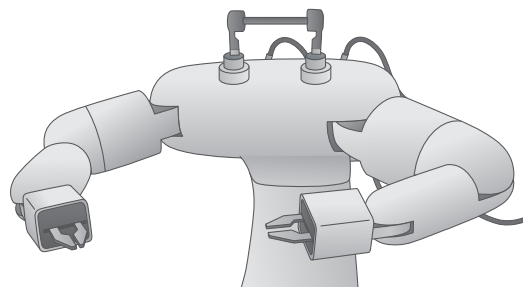
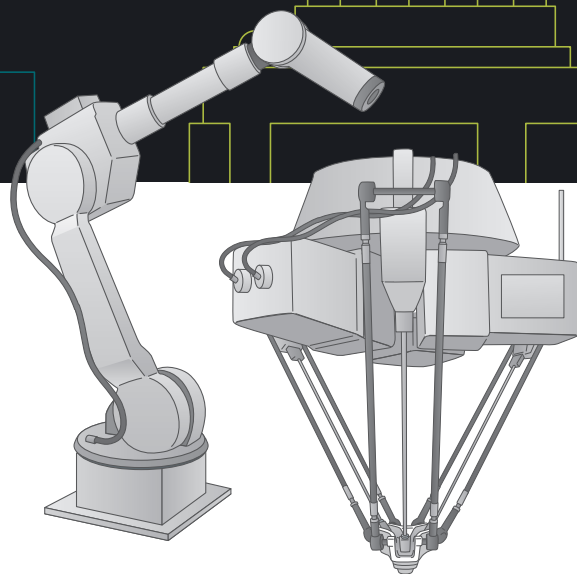

NISSEI focuses on high precision gear used in robots or machine tools.

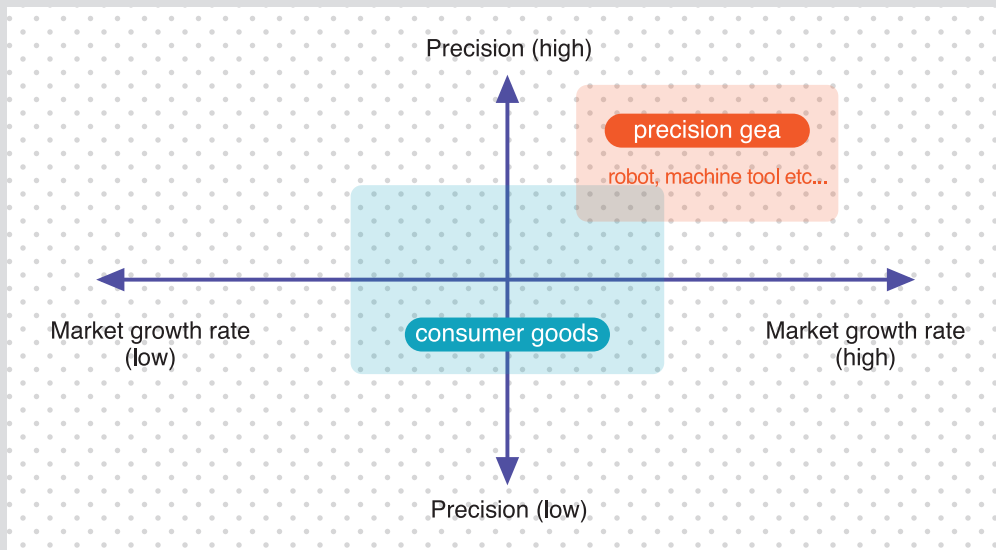

NISSEI's technology is the solution to your problems

Tasks	Higher Precision	Miniaturization	Thinner, and lighter	Enhancing Production Capacity	Unitization
NISSEI's Suggestion	Process optimization	High speed reduction gear	Whetstone and CBN gear grinding machine	Gear grinding machine facility and precision measuring instrument	Special ordered reduction gear
Design	○	○	○		○
Production Technology	○				○
Quality assurance			○	○	
Supply			○	○	○
	↓	↓	↓	↓	↓
	page 4		page 5		page 6

Task 1

Thinner, and lighter gear

Solution NISSEI's solution

1. We design the gear based on estimated heat-treatment strain
2. The strain is monitored throughout the in-company production of the heat-treatment process. The optimized process provides thinner gear.

Tooth bearing analysis (Bevel gears)

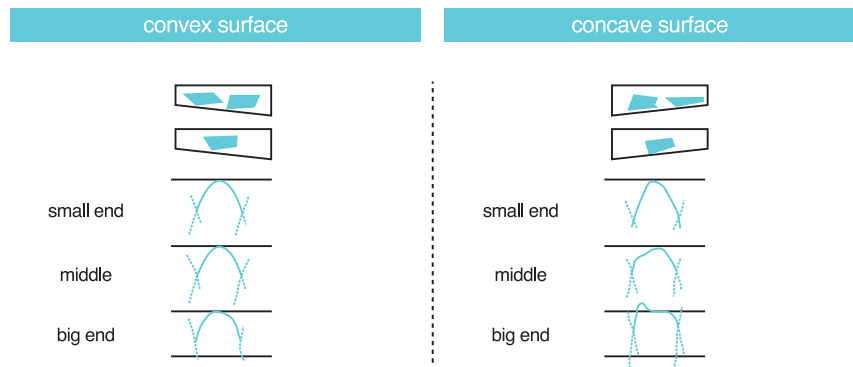

Task2

Miniaturized gear

Solution NISSEI's solution

1. Our originally developed HRH(High Ratio Hypoid) Gear enables a larger reduction ratio in one pair, making compact designs possible.

Hypoid gear	rapid rate	1/5 - 1/10
HRH	rapid rate	1/10 - 1/120

Reduction ratio

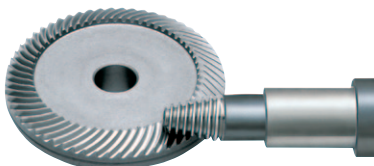
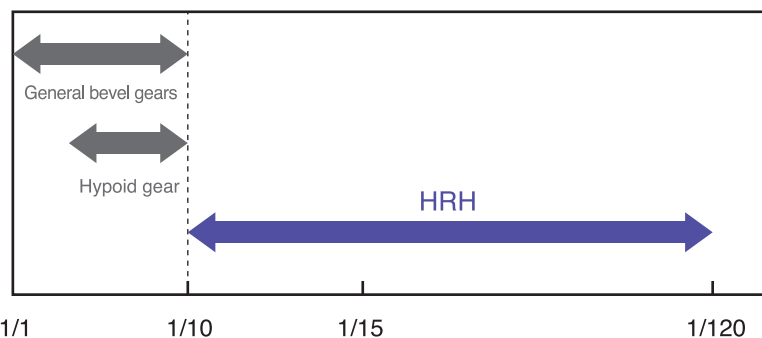

Task 3

Higher precision gear

Solution NISSEI's solution

- ➔ 1. For higher precision, finishing touches by whetstone gear grinding machines are available.
- ➔ 2. For customers who value cost and quality balance, finishing touches by our CBN gear grinding machine is recommended.

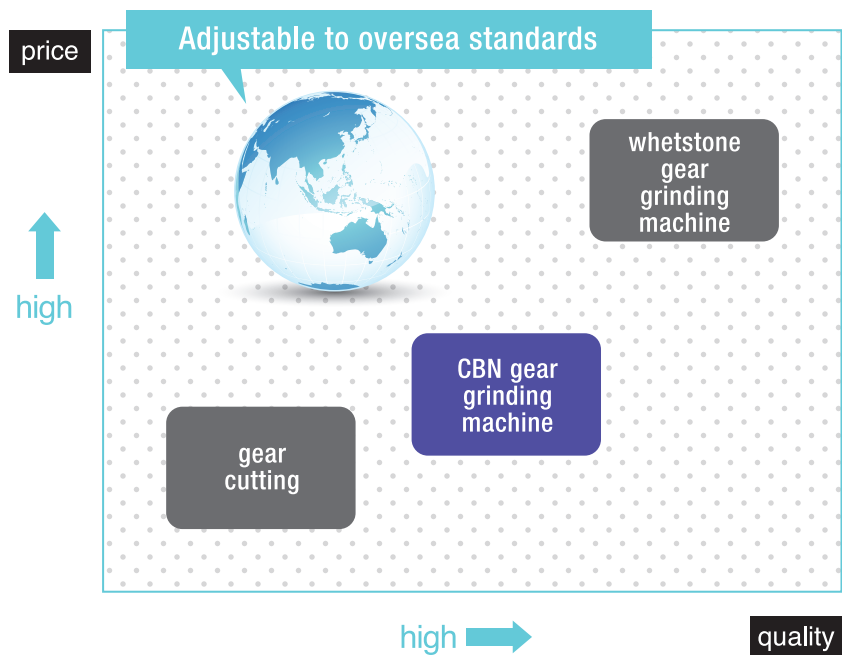

Precision of bevel gears (approximate)

unit: class

JIS	DIN	AGMA	gear surface
0	5 6	13 12	whetstone gear grinding machine
1	7	11	
2	8	10	CBN gear grinding machine
3	9	9	
4	10	8	gear cutting

*JIS: B1704 (old JIS)



Task 4

Enhancing Production Capacity

Solution NISSEI's solution

- ➔ 1. With plenty of gear grinding machinery and high precision measuring instruments, we handle from small to large lots.

● Bevel gear grinding machines	4
● Bevel CBN gear grinding machines	12
● 3D measuring instruments.	2

3D measuring instrument



Bevel gear grinding machine
(Gleason Corporation, Phoenix)



3D measuring instrument
(Carl Zeiss)

Task 5

Purchasing in Units

Solution NISSEI's solution

- ➔ 1. We have strong confidence in making specially ordered reduction gear for each customer.



unit
drawing

design
analysis

integrated
production
system

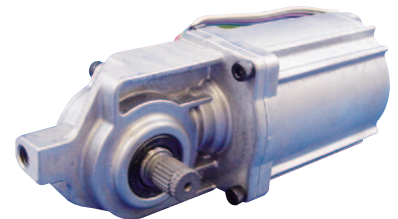

Combining our experience with gears, die casting, motors, we are able to produce specially adjusted reduction gear. NISSEI's original technology HRH enables efficiency and space-saving. CBN gear grinding machine can now be provided at a lower price, with the same high precision.

We also have suggestable gear motors for a range of machinery.

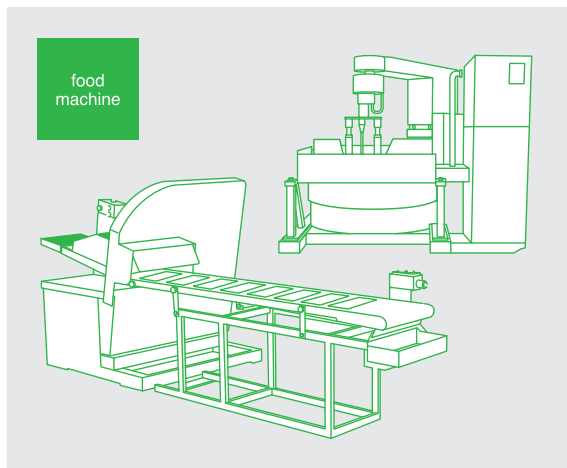
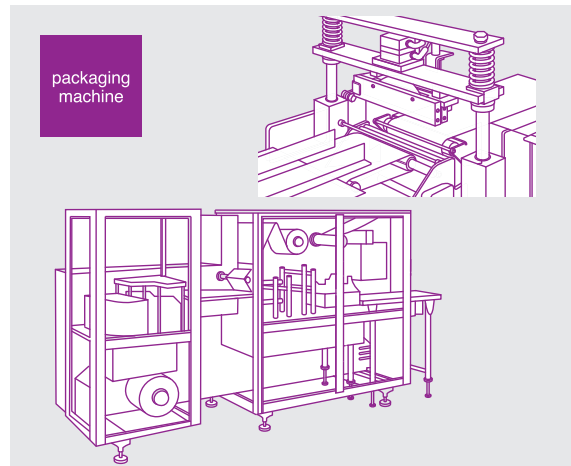
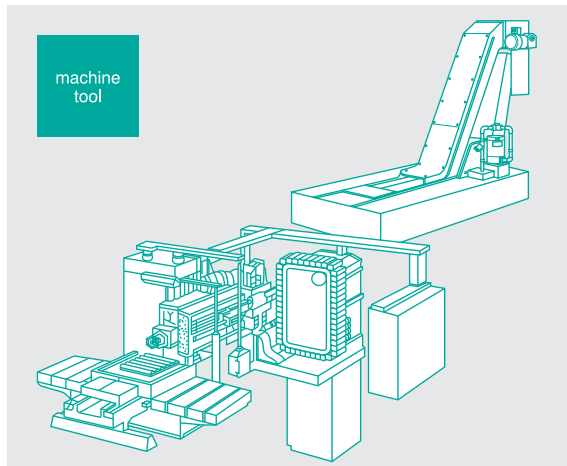

For information on prices and schedule, please contact as listed below.



【For customers in Hokkaido, Tohoku, and Kanto-Koshinetsu area】

<p>Tokyo office</p>	<p>ZIP 103-0011 2F Nihonbashi Odemanmachi Plaza building, 1-8 Odenma Nihonbashi Chuo-ku Tokyo, Japan TEL (+81)3-5695-5411 (Main) FAX(+81)3-5695-5418 Email tokyo@nissei-gtr.co.jp</p>
<p>Tohoku representative office</p>	<p>ZIP 980-0811 7F SE building 1-5-16 Ichiban-cho Aoba-ku Sendai city Miyagi, Japan TEL (+81)22-227-8885 FAX (+81)22-227-8887</p>

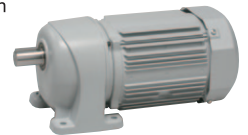

【For customers in Kinki, Chugoku, Shikoku, Kyushu and Okinawa area】

<p>Osaka office</p>	<p>ZIP 543-0072 1-18 Ikuyama-maemachi Tennoji ku Osaka city Osaka, Japan TEL (+81)6-6772-1900 (Main) FAX (+81)6-6772-0406 E-mail osaka@nissei-gtr.co.jp</p>
<p>Kyushu representative office</p>	<p>ZIP 812-0016 7F Nihonseimei Hakataminami building 1-3-1 Hakataekimae Hakata ku Fukuoka city Fukuoka, Japan TEL (+81)92-409-7385 FAX (+81)6-6772-0406</p>



【For customers in Tokai and Hokuriku area】

<p>Chubu office</p>	<p>ZIP 444-1297 1-1 Inoue Izumicho Anjo city Aichi, Japan TEL (+81)566-92-7410(Main) FAX (+81)566-92-7418 E-mail honbu@nissei-gtr.co.jp</p>
----------------------------	---



【For customers overseas】

<p>Oversea office</p>	<p>ZIP 444-1297 1-1 Inoue Izumicho Anjo city Aichi, Japan TEL (+81)566-92-5312(Main) FAX (+81)566-92-7002 E-mail oversea@nissei-gtr.co.jp</p>
------------------------------	---

GEAR

since 1955

Power Everywhere

Nissei is the all-embracing manufacturer
of transmission equipment including gear motor and gear



Company information

Company name — NISSEI CORPORATION

Capital — 3,475,000,000 JPY

Headquarter — Anjo city Aichi, Japan

Factory — Head factory Anjo minami factory Reduction gear factory #2

Listed Exchanges — Tokyo Stock Exchange, Second Section

Nagoya Stock Exchange, Second Section

Businesses — ·Reduction gear and variable speed gear : 550,000 gears per year

·Small fine-pitch gears (produced by order) : more than 18 million gears per year

Contact for precision gear inquiries

Sales department

■Development department

ZIP 444-1297

1-1 Inoue, Izumi-cho, Anjo-shi, Aichi, Japan

TEL (+81)566-92-5268(Main) FAX (+81)566-92-1159 Email gearsale@nissei-gtr.co.jp

■Overseas Sales department

ZIP 444-1297

1-1 Inoue, Izumi-cho, Anjo-shi, Aichi, Japan

TEL (+81)566-92-5312(Main) FAX (+81)566-92-7002 E-mail oversea@nissei-gtr.co.jp

Technical department

■Gear design section

ZIP 444-1297

2-15 Inoue, Izumi-cho, Anjo-shi, Aichi, Japan

TEL (+81)566-92-5253(Main) FAX(+81)566-92-5188 Email geartech@nissei-gtr.co.jp