

PS3 CONTROL UNIT

for 4-wire ribbon switches, edges and mats

Instruction use and maintenance

READ BEFORE ANY INSTALLATION

Cat 3 - PL e - Manual and automatic RESTART



IMPORTANT REMARKS ON SAFETY

Original instructions

The user is obliged to observe the new European international standards in order to make best use of the equipment for the safety of machines and plants to be protected. For this purpose it is necessary that a manager read this manual completely and follows the installation and setup of the system.

Please observe all the technical details and the suggestions reported in this manual without exception, and with strict compliance with local and national regulations to the safety of industrial machines.

This protecting system, is only a part of the entire safety equipment of the machine, the control unit described here, should be incorporated within the general electric circuit. The responsibility of the safety circuit is of the manufacturer of the machine and of the end user.

This documentation must accompany the product throughout its operating life. The people responsible must ensure that the maintenance staff, assistance and anyone is relevant to the use of the safety of the machine, have access to all the information provided by the manufacturer of these systems.

The GREIN company is not responsible for injury or damage resulting from failure to observe these directions in the use of its products.

Contents

GENERAL INFORMATIONS	pag. 4
WORKING PRINCIPLE	pag. 4
USAGE LIMITS	pag. 4
TERMS AND DEFINITIONS	pag. 4
TECHNICAL CARATTERISTICS	pag. 5
CONNECTIONS AND FUNCTIONS	pag. 6
WIRING CONNECTIONS	pag. 7
ARC SUPPRESSOR FOR PROTECTION OF RELAY CONTACTS	pag. 9
EDGES AND MATS SERIES WIRING CONNECTIONS	pag. 10
PS3 UNIT CONTROL - MECHANICAL FITTING	pag. 11
CALCULATION OF RESPONSE TIME	pag. 11
INDICATIONS	pag. 12
DIAGNOSTIC	pag. 12
SERVICE AND TEST	pag. 12
IMPOSTAZIONI E TEST	pag. 13
MAINTENANCE / SPARE PARTS	pag. 14
PACKING / HANDLING	pag. 14
STORAGE / DISPOSAL	pag. 14
PL / MTTF	pag. 15
DIMENSIONS	pag. 16
WARRANTY	pag. 17
CE DECLARATION OF CONRFORMITY	pag. 18

GENERAL INFORMATIONS

The PS3 unit control series are the controller for ribbon switches, edges and mats provided with four wire to meet category 3, Performance Level “e” according to EN ISO 13849.

The control circuit disables the internal relays when the sensor is pressed, if are cut the conductors, in case of interruption of the internal circuit of the sensor, if power failure, in case of a failure to the internal components of the safety circuit.

The PS3 control unit are provided with two safety contacts NO and one no safety NC contact.

The RESET can be automatic or manual.

If the reset is set to automatic, pressing the sensor will be deactivated the relay outputs.

When the sensor is no more pressed, the relay outputs will be automatically reactivated.

If the reset is set to manual, pressing the sensor will be deactivated the relay outputs.

When the sensor is no more pressed, to activate the relay outputs is necessary to press and release the restart pushbutton

The PS3 control unit is protected against shortcircuit, overload and polarity reversal.

The power supply available are: 24 Vdc, 24 - 115 - 230 Vca.

- WORKING PRINCIPLE

The internal circuitry of the sensing element can be intended as a normally open contact. If open, the sensor is not active and the internal relays are activated.

When the sensor is pressed, the internal circuit of the sensor is closed and the relays are deactivated.

An internal current limiting circuit provide the protection at internal control circuit when the sensor is activated.

- USAGE LIMITS

The system PS3 control unit and electrosensible element / elements is to be used in machinery and other mobile structures in order to protect people from physical damage.

For any questions, please refer to the actual Machinery Directive.

TERMS AND DEFINITIONS

OUTPUT OFF	state in which the output circuit is interrupted and does not permits the flow of current.
OUTPUT ON	state in which the output circuit is closed and permits the flow of current.
RESET	restart mode of the safety output (automatic or manual)
SENSING ELEMENT	edge, mat, bumper, ribbon switches, 4-wire with normaly open internal circuit, on which the application of a force permit the change of state of the output signal of the PS3 control unit.
SENSING ELEMENT ACTIVE	Sensor subject to an external force such as to determine the closing of the contact inside.
SENSING ELEMENT DEACTIVE	Sensor subject to an external force such as not to determine the closing of the contact inside.

TECHNICAL CHARACTERISTICS

GENERAL	
Safety Level	Type 3 - PL e - Cat. 3
Power Supply	24Vcc ± 10% PELV / 24-115-230 Vca ± 10%
Max current with sensor deactivated	55 mA
Max current with sensor activated	45 mA
Max current in the sensor	100 mA
Working Temperature	-5 ÷ 60 °C
Relative umidity	5 - 95%
IP	20
Weight	190 grams
Response Time	18 ms, restart 280 msec
Max controlled lenght for edges	60 m
Max controlled area for mats	15 m ²
Max controlled edges	equal to the max length of the single edge
Max controlled mats	equal to the max area of the single mat
Max lenght connections edge/control unit	250 m with copper cable - 0.35 mm ²
Max lenght connections mat/control unit	100 m with copper cable - 0.35 mm ²
SAFETY RELAY - OUTPUT CONTACT	
Contact material	AgSnO ₂
Working voltage	AC 230V; DC 300V
Max switching voltage	6A
Max constant current	2A
Max switching capability	1500VA
Mechanical service life	10 ⁷
Electrical service life	10 ⁶

LIST OF MODELS

DIN rail enclosure IP20		
ORDER CODE	MODEL	POWER SUPPLY
P-09	PS-3 / A1	24 Vca
P-10	PS-3 / A2	115 Vca
P-11	PS-3 / A3	230 Vca
P-12	PS-3 / A5	24 Vdc

IP56 enclosure		
ORDER CODE	MODEL	POWER SUPPLY
P-13	PS-3-56 / A1	24 Vca
P-14	PS-3-56 / A2	115 Vca
P-15	PS-3-56 / A3	230 Vca
P-16	PS-3-56 / A5	24 Vdc

CONNECTIONS AND FUNCTIONS

The tables below summarize the electrical characteristics and function of each input.

Characteristics of the module with DC power supply.

PS3		A5 24 Vdc			
Pin N	Function	Description	Type	Level	
1	+24V	Positive power supply	IN	+24Vdc +/- 10% 0.2A	
2	GND	0V power supply	IN	0V	
3	PE	ground	-	-	
4	Reset	Common RESET	OUT	0 - 24 Vdc	10mA
5	Automatic reset	Selection automatic RESET	IN	0 - 24 Vdc	10mA
6	Manual reset	Selection manual RESET	IN	0 - 24 Vdc	10mA
7	Input sensor A	Wire A input	IN	0 - 24 Vdc	10mA
8	Input sensor B	Wire B input	IN	0 - 24 Vdc	10mA
9	Input sensor C	Wire C input	IN	0 - 24 Vdc	10mA
10	Input sensor D	Wire D input	IN	0 - 24 Vdc	10mA
11	Relay output N.C.	NC Contact	OUT	0 - 230Vac	6A
12	Relay output N.C.	NC Contact	OUT	0 - 230Vac	6A
13	Relay output N.O.	Safety contact NO channel 0	OUT	0 - 230Vac	6A
14	Relay output N.O.	Safety contact NO channel 0	OUT	0 - 230Vac	6A
15	Relay output N.O.	Safety contact NO channel 1	OUT	0 - 230Vac	6A
16	Relay output N.O.	Safety contact NO channel 1	OUT	0 - 230Vac	6A

Characteristics of the modules with AC power supply.

PS3		A1 24 Vac - A2 110 Vac - A3 220 Vac			
Pin N	Function	Description	Type	Level	
1	24 -115 - 230 Vac	Power supply	IN	24 -115 - 230 Vac +/- 10% 0.2A	
2	24 -115 - 230 Vac	Power supply	IN	24 -115 - 230 Vac +/- 10% 0.2A	
3	PE	ground	-	-	
4	Reset	Common RESET	OUT	0 - 24 Vdc	10mA
5	Reset automatico	Selection automatic RESET	IN	0 - 24 Vdc	10mA
6	Reset manuale	Selection manual RESET	IN	0 - 24 Vdc	10mA
7	Sensore ingresso A	Wire A input	IN	0 - 24 Vdc	10mA
8	Sensore ingresso B	Wire B input	IN	0 - 24 Vdc	10mA
9	Sensore ingresso C	Wire C input	IN	0 - 24 Vdc	10mA
10	Sensore ingresso D	Wire D input	IN	0 - 24 Vdc	10mA
11	Relay output N.C.	NC Contact	OUT	0 - 230Vac	6A
12	Relay output N.C.	NC Contact	OUT	0 - 230Vac	6A
13	Relay output N.O.	Safety contact NO channel 0	OUT	0 - 230Vac	6A
14	Relay output N.O.	Safety contact NO channel 0	OUT	0 - 230Vac	6A
15	Relay output N.O.	Safety contact NO channel 1	OUT	0 - 230Vac	6A
16	Relay output N.O.	Safety contact NO channel 1	OUT	0 - 230Vac	6A

The contact status is referred to the control unit without power or with sensing element active.

Block Diagram of working principle

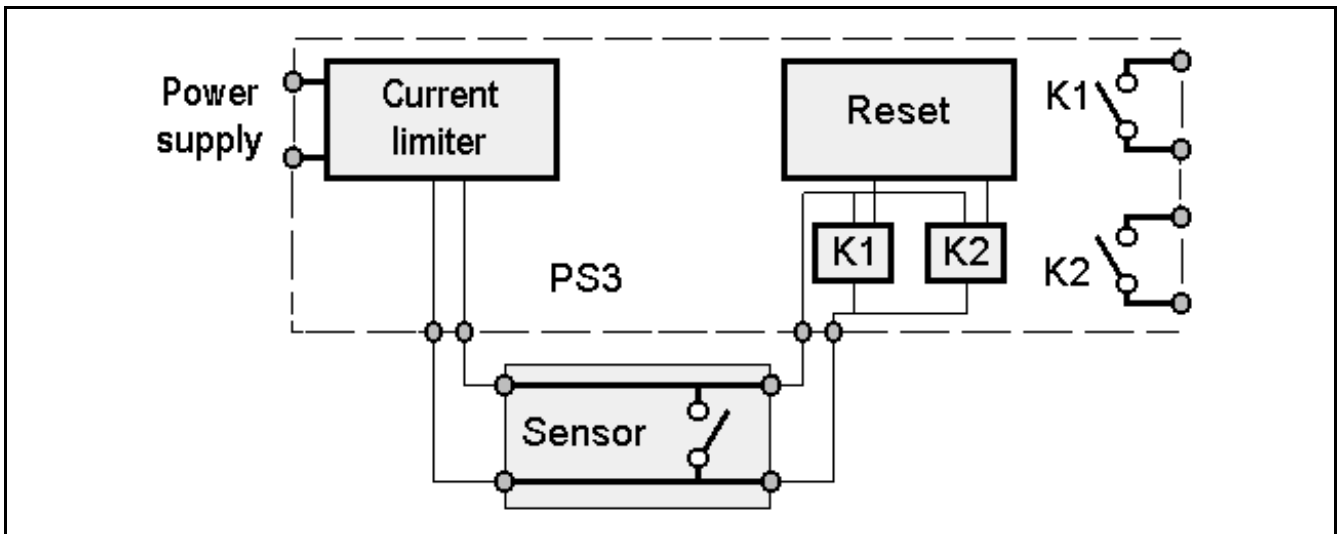

On the control module PS3 is available the automatic or manual reset.

Automatic: The force applied to the sensor deactivate the relays outputs. Removing the activation force on the sensor, the relays outputs will be automatically reactivated.

Manual: The force applied to the sensor deactivate the relays outputs. To reactivate the outputs is necessary to remove the activation force on the sensor, and press and release the manual restart pushbutton.

The following figures show the selection of the restart mode.

Reset connection	
<p>Terminal 4 - 5</p> <p style="text-align: center;">Automatic RESET</p> <p>To set the automatic RESET make a jumper on pins 4 and 5 as shown in the figure.</p>	<p>The diagram shows a terminal block with 8 pins. Pins 1, 2, 3, 4, 5, 6, 7, and 8 are labeled. A jumper is connected between pins 4 and 5. The terminal block is connected to POWER SUPPLY, RESET CONTROL, and IN SEN.</p>
<p>Terminal 4 - 6</p> <p style="text-align: center;">Manual RESET</p> <p>To set the manual RESET, insert between pin 4 and 6 a normally open pushbutton as shown in the figure.</p>	<p>The diagram shows a terminal block with 8 pins. Pins 1, 2, 3, 4, 5, 6, 7, and 8 are labeled. A normally open pushbutton is connected between pins 4 and 6. The terminal block is connected to POWER SUPPLY, RESET CONTROL, and IN SEN.</p>

The manual switch should be located out to dangerous zone. The operator should not be able to restart the machine if it is inside the dangerous zone.

WIRING CONNECTIONS

CONNECTION CABLES WARNING

- 1 - All the cables from sensor to the control module shall be separated from power .
- 2 - The PS3 power supply should be separated by power supply of the power equipment(i.e. inverters)
- 3 - If there is the possibility to damage the cables, take care to protect them against crushing or cutting.

EXAMPLE OF CONNECTION 1

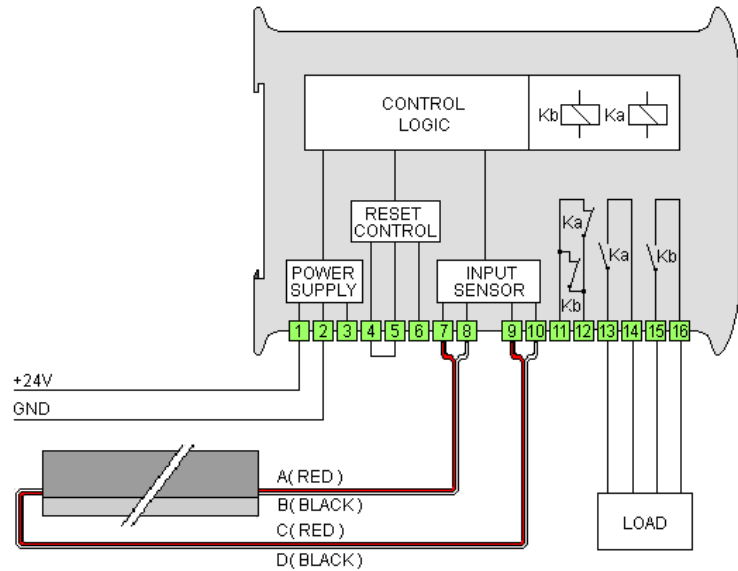

In this example the PS3 24Vdc control unit is connected to a safety edge.
The reset is automatic.

EXAMPLE OF CONNECTION 2

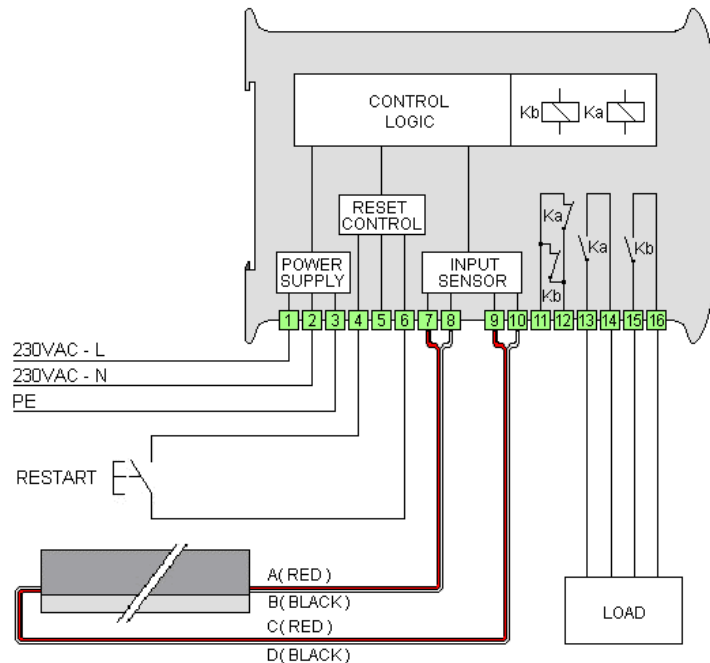

In this example the PS3 230 Vca control unit is connected to a safety edge.
The reset is manual (see the push button RESTART).

EXAMPLE OF CONNECTION 3

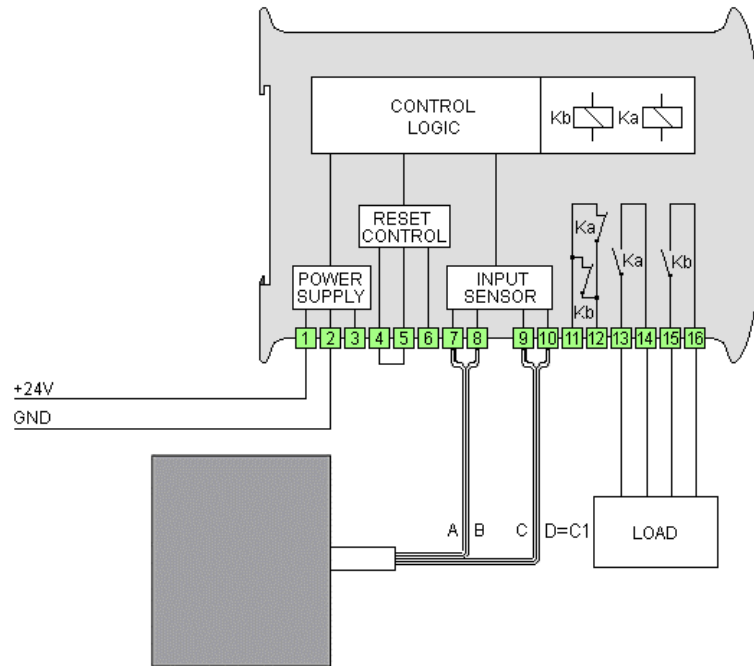

In this example of connection the PS3 24 Vdc control unit is connected to a safety mat. The reset is automatic.

ARC SUPPRESSOR FOR PROTECTION OF RELAY CONTACTS

Two noise filter (S1 and S2) must be connected across the coil K1 and K2 of the machinery control device, to avoid spikes on the relay contacts and increase their life.

S1 and S2 must be connected always and only in parallel to the load, must never be connected in parallel on the safety contacts of the relay outputs.

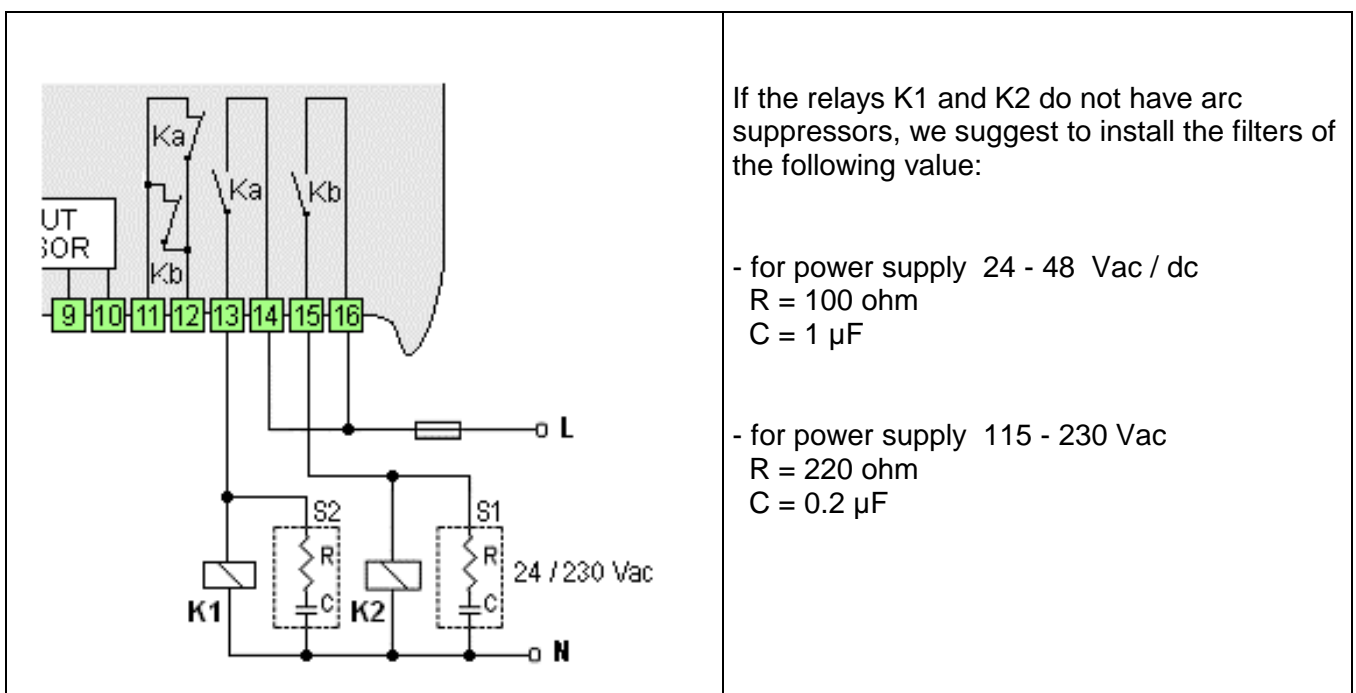

EDGES AND MATS SERIES WIRING CONNECTIONS

The figure below shows the terminals on the edge with their color and name. For the connection, refer to the examples in the "wiring connection" chapter.

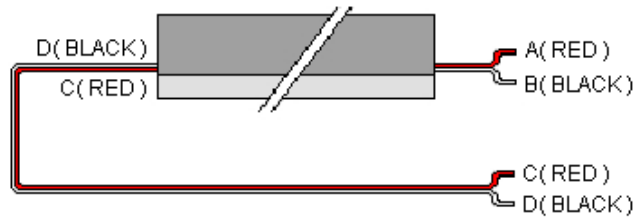

The figure below shows the edges series connections. See "TECHNICAL CARATTERISTICS" on page 5 for the max number of edges that can be connected in series.

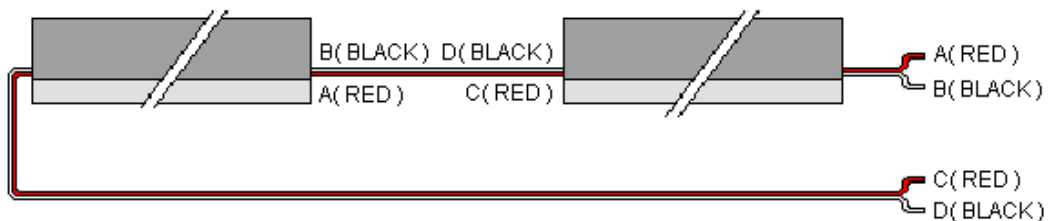

The figure below shows the terminals on the mat with their name. Regardless of the position of the cable outlet and the number of cables, the name of cables do not change.

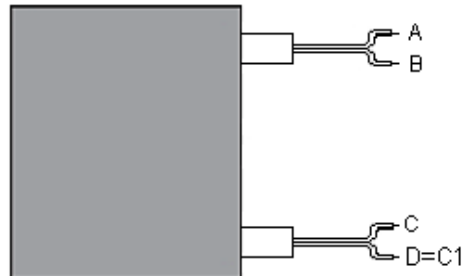

The figure below shows the mats series connections. See "TECHNICAL CARATTERISTICS" on page 5 for the max number of mats that can be connected in series.

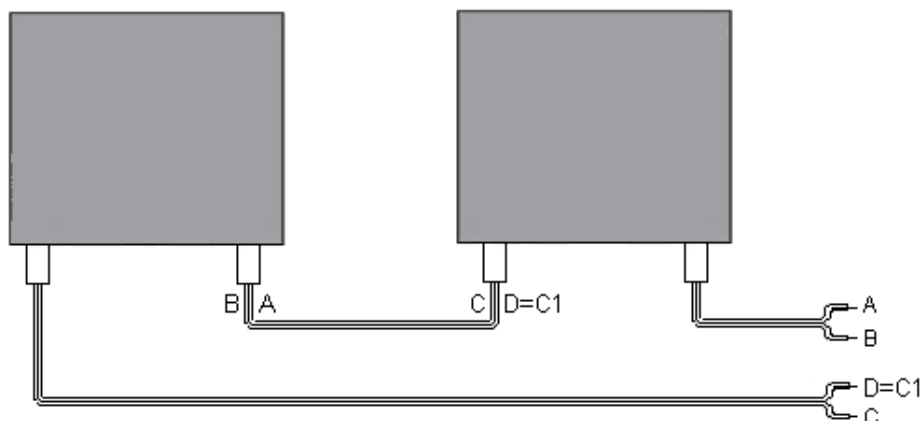

NOTE

With a multimeter setted on the continuity test, check that on edge or mat deactivated, between the terminals A-B and C-D there is a normaly open circuit. Otherwise, if the edge or mat is activated, between the terminals A-B and C-D there is a normaly close circuit.
In all case (edge or mat, activated or deactivated) between the terminals A-C and B-D there is always a short circuit.

PS3 CONTROL UNIT - MECHANICAL FITTING

The PS3 control unit in DIN enclosure, should be fixed properly following these guidelines:

- 1) In a control cabinet protected from dust / moisture with a minimum IP54 protection degree.
- 2) Fix it in a DIN rail 35 mm according to EN 50 022
- 3) Do not mount the PS3 control unit near sources of intense heat.
- 4) The PS3 control unit can be mounted in any position

The PS3 unit control in IP56 enclosure does not require compliance with the guidelines above. This module is equipped with a IP56 degree of protection.

CALCULATION OF RESPONSE TIME

The total response time is given by the sum of the response time of the control module PS3-AX and the response time of the sensitive element.

Total response time = PS3-Ax response time + sensor response time

The PS3 unit control response time is 18 ms, the sensitive element response time is to be obtained from the manual of use and installation of the edge or mat.

Example:

Calculation of the response time of the PS3 unit control and the GREIN safety mat.
In reference to the manual of the mat we obtain a response time of 60ms.

Total response time = PS3-AX response time + sensitive element response time
= 18 ms + 60ms = 78ms

INDICATIONS

The indications assume different roles depending on the state of the sensor, relays outputs and power supply.

POWER	YELLOW - Power On
--------------	-------------------

If the indicator is ON, the power supply is connected correctly.

SENSOR CLEAR	GREEN – Status of the sensor
---------------------	------------------------------

If the indicator is ON, the sensor is connected correctly and is deactivated,
If the indicator is OFF the sensor is activated or there is a mistake on the connections.

OUTPUT ON	GREEN - Relays Output State
------------------	-----------------------------

If the indicator is ON, the relays are active, otherwise the relays are deactivated.

DIAGNOSTIC

POWER	SENSOR CLEAR	OUTPUT ON	DESCRIPTION
ON	ON	ON	Power supply ON, sensor free, relays active. The control unit is working properly. To test the correct operation activate the sensor and verify the deactivation of the outputs relays and the indicators "SENSOR CLEAR" and "OUTPUT ON" are OFF.
ON	OFF	OFF	Power supply ON, sensing element activated or not properly connected. Turn off the control unit, check the cable connection and the sensor as reported in page 10-11. Give power to the PS3 control unit. If the problem is not solved, contact the GREIN customer service.
ON	ON	OFF	Power supply ON, sensor free, the relays outputs are deactivated. Turn off the control unit, check the reset circuit. The causes could be: automatic RESET, there is not the jumper between the inputs 4-5; manual RESET, error in the push button connection. After these checks power the PS3 control unit. If the problem is not solved, contact the GREIN customer service.
ON	BLINK	BLINK	Power supply ON, setting error of reset circuit. Turn off the control unit, check the reset connections, in function to the mode of choice reset. Possible causes could be, pushbutton connected normally closed instead of normally open or broken. After these checks power the PS3 control unit. If the problem is not solved, contact the GREIN customer service.
OFF	OFF	OFF	No power supply or intervention of internal protection against overload. Turn off the control unit, check the polarity, wait a few minutes to restoration of internal protection. After these checks power the PS3 control unit. If the problem is not solved, contact the GREIN customer service.

SERVICE AND TEST

Attention

Each repair operation should be performed only by GREIN authorized technicians.

Putting into service and tests at regular intervals

The installer that puts the equipment into service shall have all necessary information about the machine or the plant, of the installed PS3 control unit and of the sensing element (mat or edge).

The test shall cover the correct interaction of the PS3 unit control / sensing element and the control system of the power operated working equipment, the safe state and the construction in compliance with the equipment specific safety rules.

The test relevant information provided by the machine or plant manufacturer shall always be observed when testing.

The frequency of the periodic tests must be in accordance with the requirements of national law.

A distinction is made between the following types of test:

Testing prior to put a device into service for the first time and after modifications

A person authorized and qualified, should test the PS3 control unit , the sensing element connected to it, the first time it is put into service and all units involved in the safety function of the machinery. All changes on the configuration of the PS3 unit control , the sensing element connected to it and the components / units that affect the safety function must always be checked. For proper interaction with the PS3 control unit, the sensitive element connected to it must be checked that all the external components to it are tested.

Periodical tests

Periodical tests serve the purpose of systematically detecting and removing safety-relevant deficiencies (e.g. in the event of modification or manipulation) of the protective equipment of the machine or facility which occur after the machine/facility having been put into service. Type, scope and time intervals to be followed are listed in clause "SETTING UP AND TEST" and shall be determined and specified for each individual machinery. For all tests, must be complied with the requirements of national law. The test results shall be recorded in a report which is to be signed by the inspector.

The report shall be kept at the installation site of the machine or plant.

SETTING UP AND TEST

FINAL CHECK BEFORE STARTING

Before connecting the PS3 control unit to the power supply, ensure that:

- The value of the supply voltage is the same reported on the label;
- Check the connection cables between mat or edge and control unit;
- If necessary to increase the safety, set the manual reset.

If the above steps are correct, power the PS3. Check that the Power and Sensor Clear indicators are ON. If is set the automatic reset, the OUTPUT ON indicator is ON and the relays outputs are active.

If set the manual reset, press and release the RESTART pushbutton, the OUTPUT ON indicator will turn on and the relays outputs are active.

INITIAL AND PERIODICAL TEST

Hint:

to ensure higher safety level, perform these tests in manual reset.

Verifica giornaliera del dispositivo di protezione da parte del personale autorizzato

Check the following points:

- damage or wear of the sensitive element,
- damage or wear of the START pushbutton (if set the MANUAL RESET)
- damage or wear of the connection cables between the sensor and the control unit.

Power the PS3 control unit.

If set the manual reset, press the pushbutton to check the correct activation of the relays outputs.

Press the sensing element, check that the relays outputs are deactivated.

Release the sensing element, check according to the mode of reset the activation of the relays outputs. If all the above points are correct, the test can be considered concluded positively, if some point is not satisfied, check the problem ad possible solution as reported in the DIAGNOSTIC paragraph.

MAINTENANCE



The maintenance instructions must be read before any maintenance to the machine, the control unit and sensing element.



All machine parts removed for maintenance operations must be restored, if these parts are not properly attached, the device performance may be affected.

Periodically clean the mat or the edge to prevent dirt or other materials that could cause malfunctions. Evaluate, following the guidelines in the data-sheet of the mat or edge, the chemicals that could cause damage to the surface.

SPARE PARTS



Only parts approved by the manufacturer may be substituted; the use of unauthorized parts or if changes are made to the control unit edge or mat, the device performance may be affected.

PACKING AND UNPACKING



Always observe the standards and regulations regarding the prevention of accidents when handling the product.

PRODUCT PACKAGING

The shape, size and content of the package varies depending on the number of control units and, in the case of the presence of the sensitive element, the geometric conformations of this.

UNPACKING GUIDELINES

When unpacking the product, follow these guidelines:

- 1) Inspect the package to check for damaged or missing items;
- 2) Proceed with unpacking paying particular attention to the opening of the package, if you use the cutter be careful not damage the surface of the products;
- 3) If there are in the same packaging the sensitive elements, not extract them from the pack by pulling on the connection cables.

HANDLING GUIDELINES

To prevent damage or personal injury follow these guidelines when handling the product:

- 1) pay attention during handling of the product;
- 2) leave the product in its original packaging;
- 3) if supplied long edges packed in rolls, unpack them immediately and store straight.

STORAGE

If the product is not installed immediately after delivery, store the product in a dry place at a constant temperature as a temperature range between -10 and +60°C.

DISPOSAL

Dispose of this product and its components in accordance with state and local codes.

PL / MTTF

The value of the PL and MTTFd does not depends on the model of the PS3 control unit.

The max number of edges that can be connected to PS3 control unit is equal to the max length of the individual edge. The max length is 60m.

The max number of mats that can be connected to PS3 control unit is equal to the max area of the individual mat. The max area is 15m².



The safety device formed by PS3-Ax control unit and the 4-wire sensing element (see page 4) assumes the value PL = e. This value must be used to calculate the total PL of machinery where this safety device is installed.

DC13 - 24 Vdc/0.5A						
Number of commutations	30s		60s		1h	
	MTTFd (years)	PL	MTTFd (years)	PL	MTTFd (years)	PL
	42,75	e	85,11	e	3336,85	e

AC13 - 230 Vac/0.6A						
Number of commutations	30s		60s		1h	
	MTTFd (years)	PL	MTTFd (years)	PL	MTTFd (years)	PL
	63,58	e	126,32	e	4240,87	e

DIMENSIONS

DIN RAIL

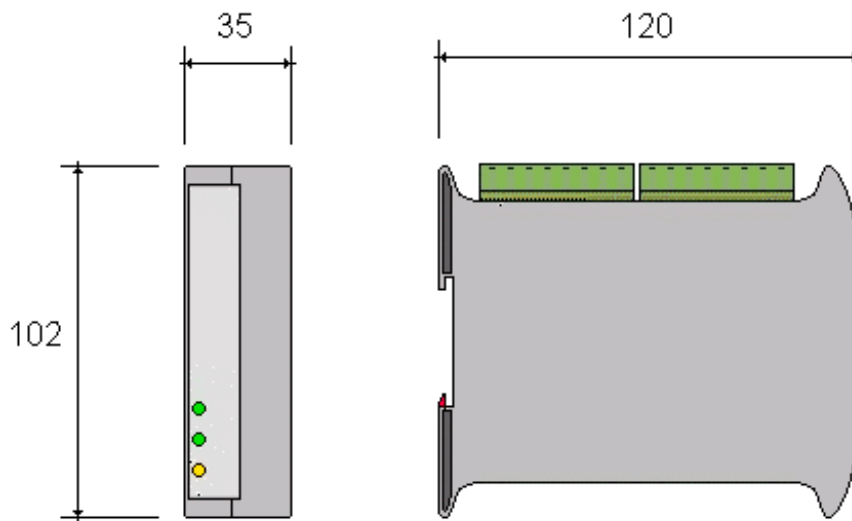

IP56

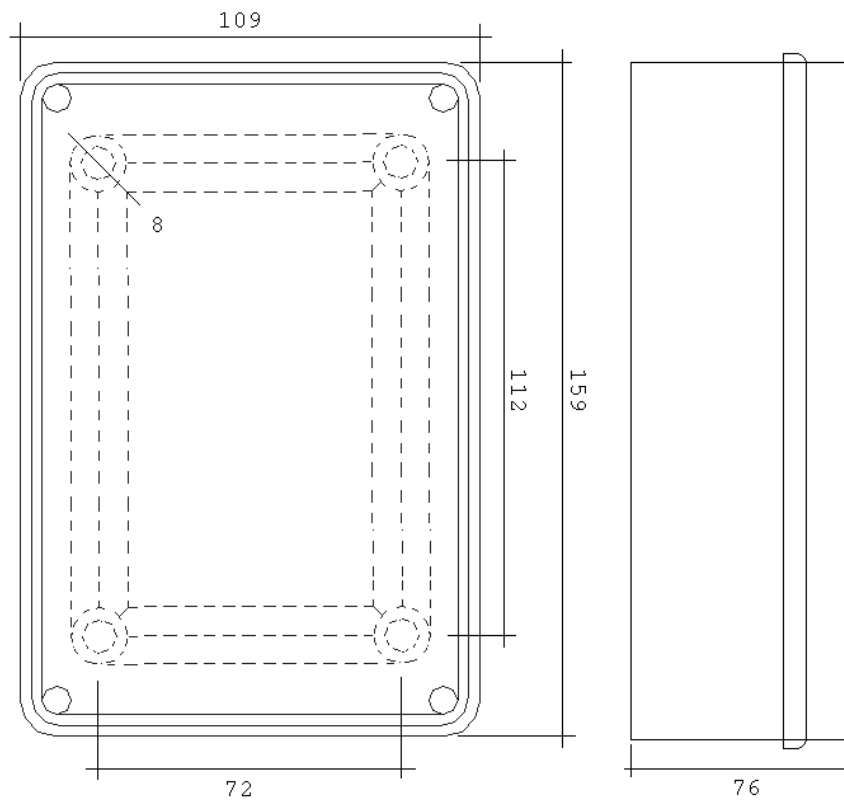

Warranty

A guarantee is provided for a period of 12 months from the delivery date and terminates at the expiration of this term, even if the materials have not been used for any reason.

Our company undertakes to repair or replace, during this period, free of charge, within the shortest possible time, those parts which owing to poor quality of material or defective workman-ship or inaccurate assembly should prove defective. This is providing that defects are not due to:

- wear and tear
- failure caused by inexperience or negligence
- unauthorized intervention or tampering
- overloads behind contract limits
- accidental causes or "force major"

The repairs or replacements shall be carried out in our workshop in Milan, Italy.
Transport will be completely charged to the purchaser.

Nothing will be due to the customer for the time during which the plant may remain idle, nor shall he make claims or ask indemnity for charges, accidents or direct or indirect damages.

For anything else not specified or that becomes a subject of dispute, the ANIE (Italian Electrotechnical Industries Association) general sale conditions will be applied.

GREIN S.r.l. Milan

NOTE: characteristics and dimensions reported in this manual are for reference only and can be subject to change without notice.

“CE” DECLARATION OF CONFORMITY DICHIARAZIONE “CE” DI CONFORMITA’

Il fabbricante

GREIN S.r.l.

The manufacturer

Via S.G.B. de La Salle 4/A 20132 MILANO ITALY

Dichiara che

Declares that

le unità di controllo, identificate con il nome **PS3 Ax**
(x = 1,2,3,5) in abbinamento ad uno o più elementi
connessi in serie del tipo:

bordi **GR-306, GR-316, GR-503, GR-747,
GR-748, GR-757;**

tappeti **TO**

costituiscono un sistema di sicurezza **CAT 3 - PL e**
per la protezione antinfortunistica di macchine pericolose.

the control unit, identified as **PS3 Ax**
(x = 1,2,3,5) in combination with one or more elements
connected in series of the type:

edges **GR-306, GR-316, GR-503, GR-747,
GR-748, GR-757;**

mats **TO**

realizes a safety system **CAT 3 - PL e** for the health and
safety protection of dangerous machines.

Sono fabbricati conformi al campione esaminato da

Are manufactured conforms to the sample tested by

Prima Ricerca & Sviluppo S.r.l.

Via Campagna, 92
22020 Faloppio Italia

Test Report N EMCTR 120878-0

Test Report N MACTR_130565-0

Test Report N MACTR_130564-0

Test Report N MACTR_140907-0

Test Report N MACTR_140908-0

Direttive applicate

Applied directives

2006 / 42 /EC Direttiva Macchine
2006 / 95 /EC Direttiva Bassa Tensione
2004 / 108 /EC Compatibilità Elettromagnetica

Machine Directive
Low Voltage Directive
ElectroMagnetic Compatibility Directive

Norme applicate

Applied standards

UNI EN ISO 13856 – 1 (2013)

UNI EN ISO 13856 – 2 (2013)

UNI EN ISO 13849 - 1/2 (2013)

NAME : Perissinotto Antonio
POSITION : C E O GREIN S.r.l.

Milan, 18-12-2014

GREIN s.r.l.
Amministratore/Unico
A. Perissinotto

