

SANMOTION

SERVO SYSTEMS

R *3E Model*
ADVANCED
MODEL

100 VAC 30-200 W, 200 VAC 30 W-30 kW



Ver. **1.1**

SANYO DENKI

SANMOTION R

SERVO SYSTEMS

Input voltage 100, 200 VAC

Output capacity 30 W to 30 kW

Servo amplifier



Amplifier capacity 10, 15, 20, 30, 50, 100, 150, 300, 600 A

Servo motor



Flange size 40 mm sq., 60 mm sq., 80 mm sq., 86 mm sq., 100 mm sq.,
130 mm sq., 180 mm sq., 220 mm sq., 275 mm sq.



Rated output 100 VAC: 30 to 200 W
200 VAC: 30 W to 30 kW



Contents

Lineup	p. 6
Features	p. 8
List of Compatible Servo Amplifiers and Servo Motors	p. 14
Standard Model Number List	p. 18
Set Models	p. 33

Servo Amplifiers

R 3E Model Analog/Pulse Input type	p. 35
R ADVANCED MODEL	
EtherCAT Interface type	p. 55
R CANopen Interface type	p. 67
R Built-in Positioning Function type	p. 75
R Multi-axis Pulse Input type	p. 87

Servo Motors

Specifications - Servo Amplifiers +	
R2 Servo Motors (Medium Inertia)	p. 96
R1 Servo Motors (Low Inertia)	p. 108
R5 Servo Motors (Medium Inertia)	p. 110
Servo Motor Dimensions	p. 112
Options	p. 119

Linear Servo Motors	p. 139
---------------------------	--------

SANMOTION S

Servo Amplifiers and Spindle Motors	p. 145
---	--------

Models No Longer Listed and Their Replacing Models	p. 150
---	---------------

Selection Guide	p. 153
------------------------------	---------------

Safety Precautions	p. 154
---------------------------------	---------------

SANMOTION Products Lineup	p. 157
--	---------------

SANMOTION R

AC SERVO SYSTEMS

The SANMOTION R series servo systems contribute to the evolution of your devices with a rich product lineup of high-precision servo amplifiers and servo motors.

These high-precision and highly reliable systems offer a wide range of products from small to large capacity servo systems.

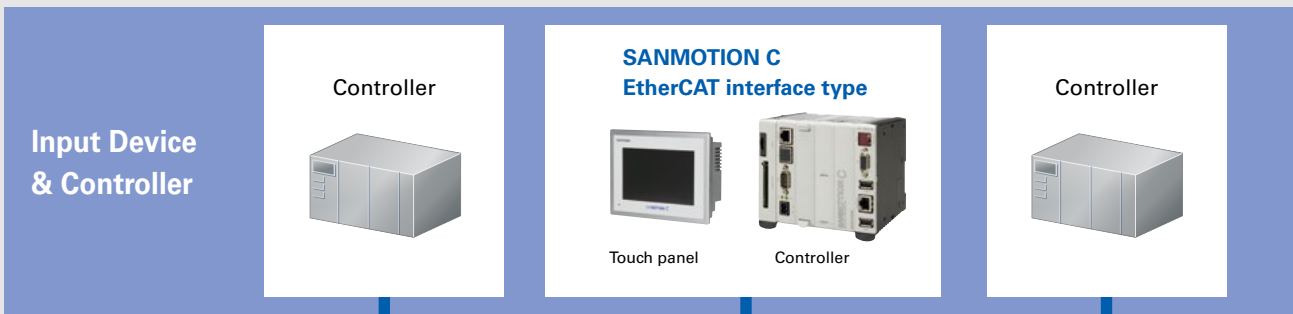

Servo system SANMOTION R



• What is servo system?

A servo system has an encoder (rotation detector) mounted on the servo motor and provides highly-reliable precise operation by giving feedback to commands from the servo amplifier. It can be used with confidence in applications that require high-speed and large-capacity operations.



NEW

Servo amplifier SANMOTION R 3E Model Amplifier capacity 100, 150, 300, 600 A

Line up of AC servo amplifier systems “SANMOTION R 3E Model” has been expanded by adding newly developed amplifiers with capacities of 100, 150, 300, and 600A. These amplifiers can drive servo motors with output of 1.8 to 30 kW.



NEW

High-precision battery-less absolute encoder Model No. HA035

The encoder is maintenance free as it does not require batteries—the service life-limited component. It is designed for use with our SANMOTION R series servo motors.



Application Examples

Its high-precision and accurate positioning features allow it to be used in a wide range of applications.

- Industrial robots, machining tools, machine centers, injection molding machines, food packaging equipment, cutting machines, chip mounters, semiconductor related equipment, medical equipment, etc.



Industrial robots



Machine tools

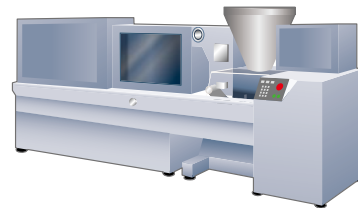

Injection molding machines

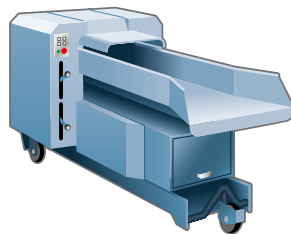

Food machinery



Chip mounters

Conformance to Safety Standards

Our standard servo amplifiers conform to safety standards such as UL, c-UL, and EN standards. R 3E Model and R ADVANCED MODEL have also acquired the KC mark. You can also employ servo motors that conform to the UL, c-UL and EN standards. (some models are still in preparation) In addition, all model numbers manufactured after October 2012 in this catalog conform with the acceptable values of specific hazardous substances (cadmium, lead, mercury, hexavalent chrome, PBB, and PBDE) in Appendix II of EU RoHS directive (2011/65/EU).



Lineup

Servo Amplifier

SANMOTION R 3E Model

Analog/Pulse Input type

More evolved AC servo amplifiers that provide improved basic performance including high responsiveness, and are more eco-efficient and easier to use.

Lineup: 10, 20, 30, 50, 100, 150, 300, 600 A

Analog/Pulse →p. 35



SANMOTION R ADVANCED MODEL

EtherCAT Interface type

The EtherCAT communication cycle is short (0.125 ms) and position commands are subdivided, making device operations smoother. It can be used together with our controller “SANMOTION C EtherCAT Interface type”.

A new product with shorter communication cycle and improved controllability. It uses a different connector from our conventional EtherCAT interface type (Model no.: RS2□□□A□K)

Lineup: 15, 30, 50, 100, 150, 300 A

EtherCAT →p. 55



SANMOTION R

CANopen Interface type

Equipped with communication protocol “CANopen interface” for embedded systems.

Lineup: 15, 30, 50 A

CANopen →p. 67



Built-in Positioning Function type

The need for a positioning control unit is eliminated, simplifying the system.

Lineup: 15, 30, 50, 100, 150, 300 A

DIO interface RS-485 communication →p. 75



Multi-axis Pulse Input type

Multi-axis controllable servo amplifier (up to 6 axes). Multiple axes can be powered and commanded from only one unit, enabling wire saving and space saving.

Amplifier Unit Lineup: 15 A (6-axis model) and 30 A (4-axis model)

Pulse input →p. 87





The products listed in this catalog have main circuit power input within range of 100 to 200 VAC. Besides them, 400 VAC and 48 VDC input servo systems are also available. See our website and catalogs for more information.

Servo Amplifier

Servo Motor (Rotary Motor)

Rotary servo motors with a wide range of products.

Motor type	Flange size, features	
R2 Servo Motor Medium inertia	40 mm sq., 60 mm sq., 80 mm sq., 86 mm sq., 100 mm sq., 130 mm sq., 180 mm sq., 220 mm sq., 275 mm sq. Medium inertia servo motors with a wide range of size variation ideal for positioning applications. Ideal for robots, injection molding machines, and general industrial machines.	
R1 Servo Motor Low inertia	180 mm sq., 220 mm sq. Low inertia servo motors that feature high-acceleration drive and high torque even at high rotational speed. Ideal for injection molding machines and general industrial machines.	
R5 Servo Motor Medium inertia	60 mm sq., 80 mm sq. Medium inertia servo motors that are ideal for smooth operations such as for the feed shaft of small-sized machine tools.	

Linear Servo Motor

Linear servo motors with large thrust force. There are two types: Flat type with core and Dual magnet type with core.

Compatible servo amplifiers: 3E Model

→p. 139



Servo Amplifier and Spindle Motor

SANMOTION S

A servo system with a spindle motor and a servo amplifier. Provides high rotational speed and high torque at low speed, which improves productivity of the device. Ideal for the main shaft of machine tools that require highly precise tapping synchronized with the feed shaft.

Lineup: Output capacity 3.2, 4.5 kW Amplifier capacity 150 A

Analog/Pulse

EtherCAT

→p. 145



SANMOTION R

AC SERVO SYSTEMS

3E Model

The 3rd generation of SANMOTION R servo amplifier series "3E Model" features evolved performance with high responsiveness and are more eco-efficient and easier to use. It contributes to improving the device performance.



Evolved

R 3E Model

Shorter takt time achieved through high-speed positioning control

The 3E Model has a speed frequency response of 2.2 kHz, approximately twice that of our conventional product.* Additionally, the position settling time has been shortened to 1/3 of the original time. Real-time switching between track control and positioning control contributes to a dramatic reduction of machine takt time.

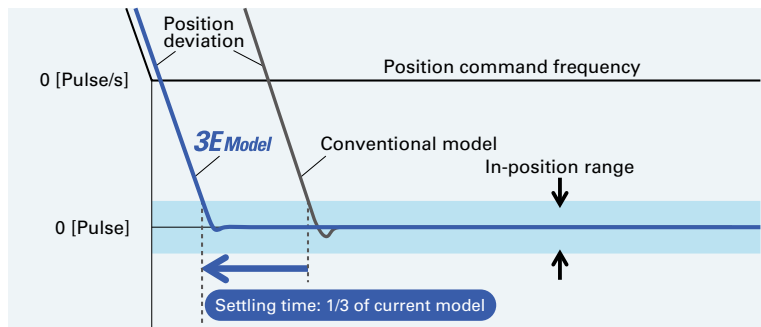

* For amplifiers with capacities from 10 to 50 A. Compared with our conventional AC servo amplifier, "SANMOTION R ADVANCED MODEL".

Improved control accuracy

The 3E Model is equipped with a gain increase function, a function for suppressing microvibrations at settling time, an adaptive notch filter for suppressing mechanical resonance, and a feed-forward vibration control function. The 4th order notch filter of our conventional products has been upgraded to 5th order.* Highly accurate machine tool feed-axis control significantly improves processing quality.

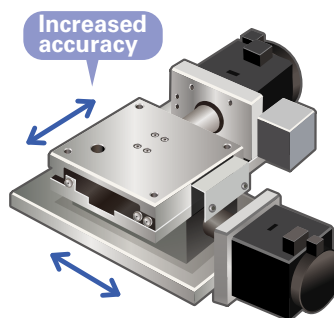

High-gain control

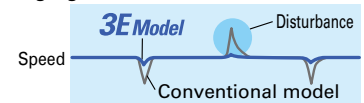

Vibration suppression by adaptive notch filter

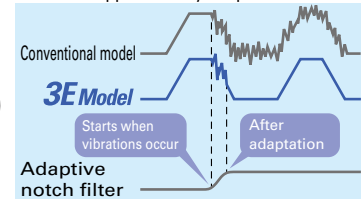

* Compared with our conventional AC servo amplifier, "SANMOTION R" ADVANCED MODEL.

Improved safety performance through the Safe Torque Off function

With the improved Safe Torque Off (STO) function, the 3E Model conforms to international standards, IEC 61508: SIL 3 and ISO 13849-1: PL=e. It is sufficiently reliable for usage in devices requiring high safety, such as medical devices.

High-precision tandem operation

In applications where two shafts are driven simultaneously, such as a gantry mechanism, high-precision tandem operation is possible by mutually compensating for deviation of motor positions between two shafts with the servo amplifier.

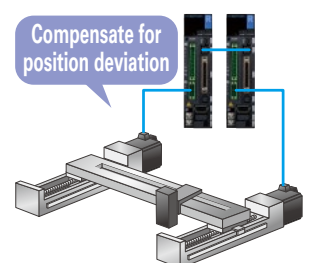

Reduced power consumption

By incorporating new-generation power devices, the 3E Model decreases electric power losses by up to 10%.* The 3E Model has up to 10% lower standby power consumption as it limits unnecessary energy consumption by controlling the fan speed according to the internal temperature of the servo amplifier.*



* For amplifiers with capacities from 100 to 300 A.

Power consumption visualization

The power consumption monitoring function enables power consumption to be visualized. The servo amplifier calculates power consumption based on the motor current, and displays it on the setup software or digital operator.

Axis	Power consumption	Unit
X	0.41	kWh
Y	0.75	kWh
Z	0.21	kWh
Total	1.37	kWh

The power consumption monitoring function is supported by the R2 and R1 servo motors only.

Easy to use

Easy startup

“SANMOTION MOTOR SETUP SOFTWARE” (see p. 120) displays the parameters required for operation in an easy-to-understand manner in order to enable fast and easy equipment startup. The 3E Model has a virtual motor operation function to simulate operation of the motor and amplifier without moving the machine, and a jog function for testing the motor and amplifier connection, without the need to connect to a host device.

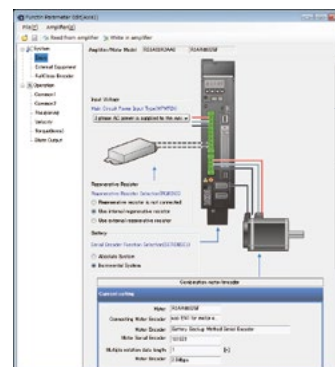

Startup time can be reduced by batch setting the minimum parameters required by application.

Easy servo tuning

By connecting with the setup software the 3E Model offers a variety of servo tuning support functions such as automatic selection of optimal tuning mode depending on mechanical and load conditions, basic tuning mode for adjustment of up to two parameters, and an application-specific tuning mode. This dramatically shortens time required for servo tuning.

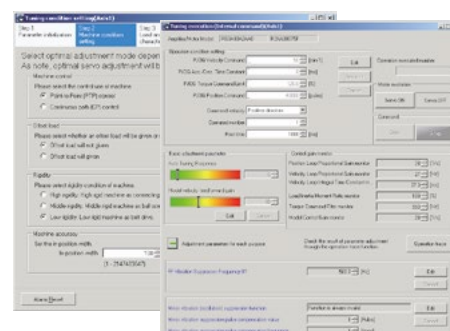

Easy troubleshooting

With a 1 ms time stamp and a drive recorder function to record motor and amplifier operating status, details of abnormal state occurrences such as alarms can be accurately checked even at a later time, facilitating troubleshooting.

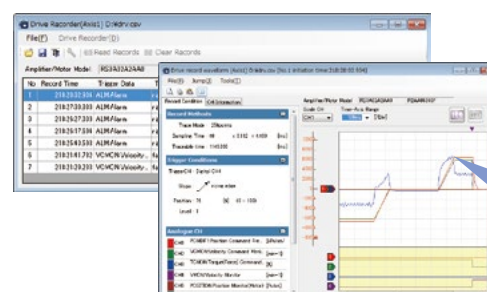

The drive recorder function allows for the checking of past operating status.

Model-based following control

R 3E Model R ADVANCED

Model-based following control enables an improved target value response, enhanced disturbance suppression, and greater robustness.

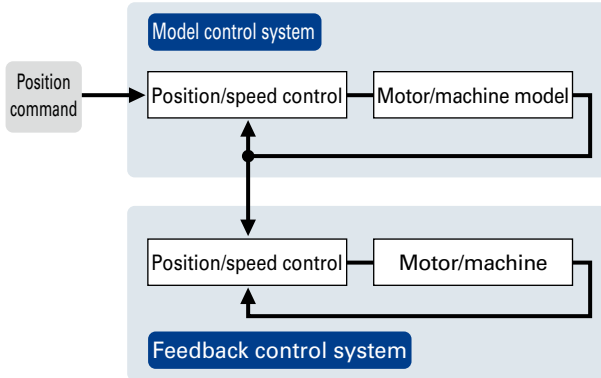

Auto-tuning

R 3E Model R ADVANCED R

The servo amplifier automatically optimizes servo gain and filter frequency in real time.

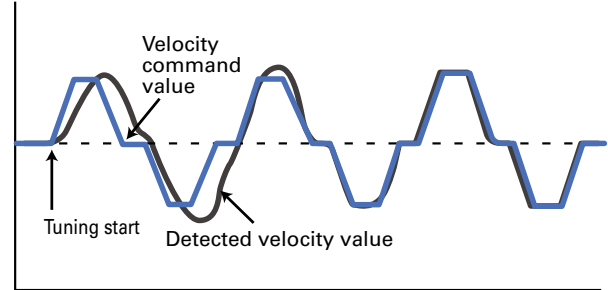

Feed-forward vibration suppression control

R 3E Model R ADVANCED R

With feed-forward vibration suppression control, vibrations at the end effector and base of a machine can be suppressed through simple tuning procedures. Vibration control frequencies are selectable.

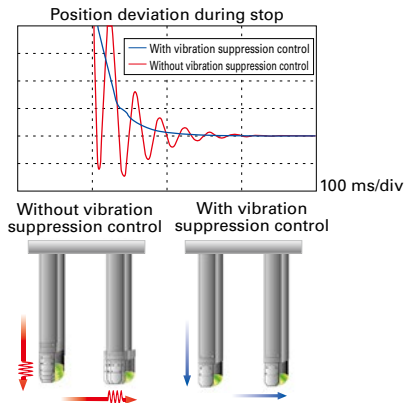

Command following control

R 3E Model R ADVANCED R

Newly-employed position and velocity controller has improved the tracking capability to the position commands. Position deviation ≈ 0 has been achieved.

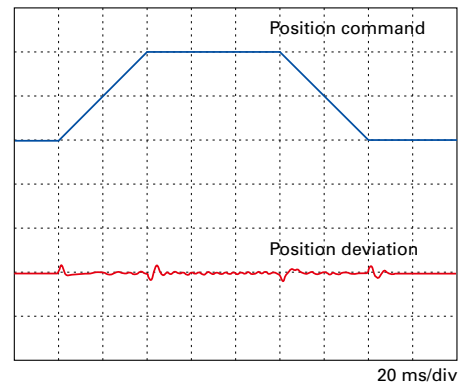

All-in-one control

R 3E Model R ADVANCED R

Configurable parameters allow switching between control modes for torque, position or velocity.

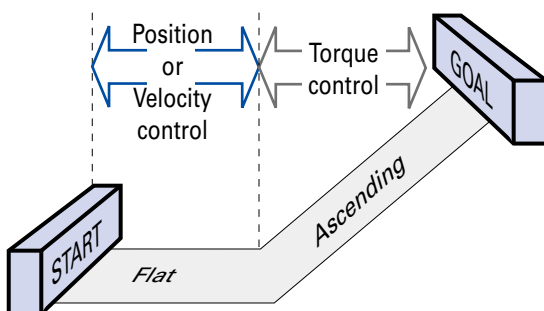

5-Digit LED display, built-in operator

R 3E Model R ADVANCED R

The built-in operator allows you to change parameters and monitor the amplifier status and alarm traces.



Multiaxial monitor function

R 3E Model R ADVANCED

The setup software allows up to 15 axes—that is, 15 sets of a servo motor and a servo amplifier—to be monitored.

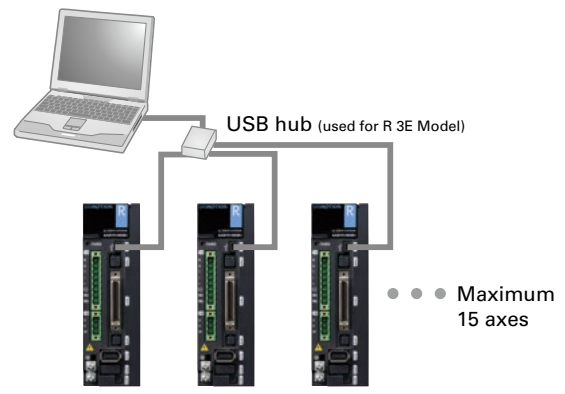

EtherCAT interface type

R ADVANCED

EtherCAT is a 100 Mbps high-speed fieldbus system. It contributes to the takt time reduction. This highly versatile EtherCAT is compatible with Ethernet, which makes it possible to build a system that co-exists with various devices. The servo amplifier firmware can be updated via EtherCAT network. Also, the EtherCAT conformance test certificate from a trusted third party has been acquired.



Dual position feedback fully-closed loop control

R 3E Model

Dual position feedback fully-closed loop control is possible by using information from two encoders: a linear encoder mounted on the device (load) and a high resolution motor-mounted encoder.

Even when there is high motor shaft torsion from the load, servo gain can be improved and high response achieved.

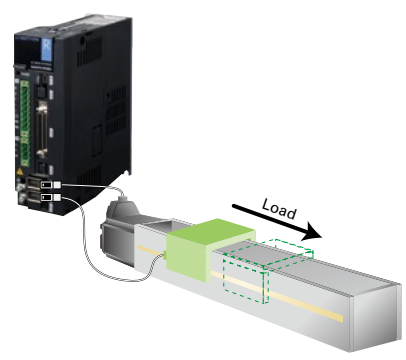

CANopen interface type

R

CANopen is based on the internationally accepted CAN automobile standard and is an open networking standard for sensors, actuators, and controllers. It is used in the field of medical equipment, FA, and logistics systems.



Built-in positioning function type

R

Models with a built-in positioning function type into the servo amplifier are available. The need for a positioning control unit is eliminated, which can reduce the number of wires and save space. There are two types of interfaces: DIO (Digital I/O) type and RS-485 communication type. Ideal for conveying applications.



Multi-axis pulse input type

R

Up to 6 axes can be combined. Multiple axes can be powered and commanded from only one unit, enabling wire saving and space saving. Also, it can contribute to eco-efficiency by utilizing regenerative energy from other axes.



Medium inertia servo motors selectable for different applications

R 3E Model R ADVANCED R

Two types of medium inertia servo motors are available: R2 servo motors with a wide lineup for positioning applications, and R5 servo motors that are ideal for smooth operations such as for feed shafts of small-sized machine tools.

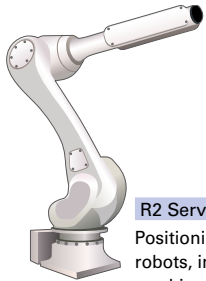

R2 Servo Motor
Positioning applications with robots, injection molding machines, general industrial machinery, etc.

R5 Servo Motor
Feed axes in machine tools



Low cogging torque

R 3E Model R ADVANCED R

Cogging torque has been reduced in comparison with our conventional products, achieving smoother movement.

Comparison of cogging torque waveforms

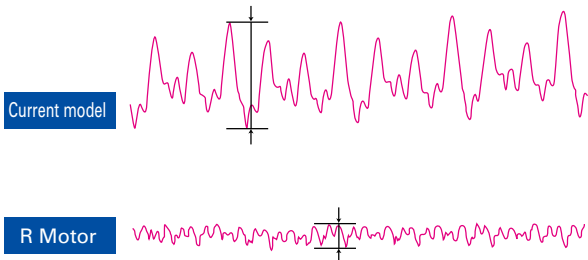

(Waveform image for reference)

Linear servo motors with large thrust force

R 3E Model

Linear servo motors that can perform direct and vertical drives and achieve large thrust force are available.



Downsized servo motors

R 3E Model R ADVANCED R

R2 series servo motors have been downsized by as much as 30% in length and 25% in volume from our conventional product, while still achieving high torque and high performance. (When using a battery-backup method absolute encoder)

* Our conventional product is "SANMOTION Q" AC servo motor.



Waterproof and dustproof

R 3E Model R ADVANCED R

Our servo motors have high waterproof and dustproof characteristics with IP65 and IP67 ratings, allowing them to work in severe environments. Servo motors with IP65 ratings can be modified to IP67 as an option.



* Except shaft openings and connector ends.

High-precision battery-less optical absolute encoder

The high-precision battery-less optical absolute encoder Model No. HA035 comes as standard.

As an option, high-precision model is also available with a maximum resolution of 8388608 (23 bits) during single rotation and an absolute angle accuracy of approximately 0.0167 deg. within a rotation (1 min.) can be selected.

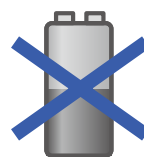

No need to worry about battery life and battery exporting procedures.

*Other than R 3E Model, some models are not compatible with optional specifications.

In addition, selecting an encoder that is optimal to the device is also available as an option.

Refer to the following table.

Serial encoder

Encoder type	Resolution during single rotation	Total number of rotations during multiple rotations	Encoder no.	Optional specifications
Battery-less optical absolute encoder This is a high-precision battery-less optical multi-turn encoder. It does not use batteries, which need to be replaced; therefore, the encoder does not require maintenance. This encoder can be broadly used for general industrial equipment including machine tools and robots. •Compatible servo amplifiers: R 3E Model and R ADVANCED MODEL servo amplifiers	131072 (17 bits)	65536 (16 bits)	Model No. HA035	<ul style="list-style-type: none"> Resolution during single rotation: 1048576 (20 bits), 8388608 (23 bits) Absolute angular accuracy within one rotation: Approx. 0.0167 deg (one minute) or lower (standard is approx. 0.167 deg (ten minutes) or lower.) Baud rate: 4.0 Mbps (standard is 2.5 Mbps)
Optical absolute encoder for incremental systems This is a slim and single-turn optical encoder. Enables wire-saving and size-reduction for applications that use pulse encoders.	131072 (17 bits)	—	Model No. PA035S	<ul style="list-style-type: none"> Resolution during single rotation: 1048576 (20 bits) Baud rate: 4.0 Mbps (standard is 2.5 Mbps)
Option Optical battery-backup method absolute encoder This is a slim multi-turn battery-backup method optical encoder. It enables the use of a shorter motor; therefore, it is optimal for devices in which motor installation space is limited. Batteries sold separately.	131072 (17 bits)	65536 (16 bits)	Model No. PA035C	<ul style="list-style-type: none"> Resolution during single rotation: 1048576 (20 bits) Baud rate: 4.0 Mbps (standard is 2.5 Mbps)
Option Resolver method battery-less absolute encoder This is a resolver method battery-less multi-turn encoder. Being a resolver method encoder with outstanding ruggedness, it is ideal for equipment used in harsh environments such as injection molding machines and robots.	131072 (17 bits)	65536 (16bit)	Model No. RA035C	<ul style="list-style-type: none"> Baud rate: 4.0 Mbps (standard is 2.5 Mbps)

Pulse encoder

Encoder type	Pulse/rotation	Multiple rotations	Encoder no.	Optional specifications
Option Optical wire-saving incremental encoder This is an incremental encoder that easily connects with host equipment to output phases A, B, and Z. Ideal for general industrial equipment such as chip mounters.	2000 P/R	—	Model No. PP031H	<ul style="list-style-type: none"> Number of pulses: Up to 10000 P/R

List of Compatible Servo Amplifiers and Servo Motors

Standard specification **C**...Output shaft: Straight, Oil seal: None, Connecting method: Cable

P...Output shaft: With key, Oil seal: Yes, Connecting method: cannon plug (15 kW or lower), Terminal block (20 kW or higher)

Analog/Pulse Input type							Servo amplifier	
Motor type	Rated output [kW]	Flange size	Model name (Partial model no.)	Standard specification	Page		R 3E Model Analog/Pulse Input type p. 35	R ADVANCED EtherCAT Interface type p. 55
					Specifications	Dimensions		
R2 Servo motor 100 V system Medium inertia	0.03	40 mm sq.	R2EA04003F	C	96	112	RS3E01□□〈10A〉	RS2E01□□〈15A〉
	0.05	40 mm sq.	R2EA04005F	C	96	112	RS3E02□□〈20A〉	RS2E01□□〈15A〉
	0.08	40 mm sq.	R2EA04008F	C	96	112	RS3E02□□〈20A〉	RS2E01□□〈15A〉
	0.1	60 mm sq.	R2EA06010F	C	97	112	RS3E02□□〈20A〉	RS2E01□□〈15A〉
	0.2	60 mm sq.	R2EA06020F	C	97	112	RS3E03□□〈30A〉	RS2E03□□〈30A〉
R2 Servo motor 200 V system Medium inertia	0.03	40 mm sq.	R2AA04003F	C	98	112	RS3A01□□〈10A〉	RS2A01□□〈15A〉
	0.05	40 mm sq.	R2AA04005F	C	98	112	RS3A01□□〈10A〉	RS2A01□□〈15A〉
	0.1 (0.09)*1	40 mm sq.	R2AA04010F	C	98	112	RS3A01□□〈10A〉	RS2A01□□〈15A〉
	0.1	60 mm sq.	R2AA06010F	C	98	112	RS3A01□□〈10A〉	RS2A01□□〈15A〉
	0.2	60 mm sq.	R2AA06020F	C	99	112	RS3A02□□〈20A〉	RS2A01□□〈15A〉
		80 mm sq.	R2AA08020F	C	99	112	RS3A02□□〈20A〉	RS2A01□□〈15A〉
	0.4 (0.36)*1	60 mm sq.	R2AA06040H	C	99	112	RS3A02□□〈20A〉	RS2A01□□〈15A〉
		60 mm sq.	R2AA06040F	C	99	112	RS3A02□□〈20A〉	RS2A03□□〈30A〉
	0.4	80 mm sq.	R2AA08040F	C	100	112	RS3A02□□〈20A〉	RS2A03□□〈30A〉
	0.55	130 mm sq.	R2AA13050H	P	101	113	RS3A03□□〈30A〉	RS2A03□□〈30A〉
		130 mm sq.	R2AA13050D	P	101	113	RS3A03□□〈30A〉	RS2A03□□〈30A〉
	0.75	80 mm sq.	R2AA08075F	C	100	112	RS3A03□□〈30A〉	RS2A03□□〈30A〉
		100 mm sq.	R2AA10075F	C	100	112	RS3A03□□〈30A〉	RS2A03□□〈30A〉
		86 mm sq.	R2AAB8075F	C	102	112	RS3A05□□〈50A〉	RS2A05□□〈50A〉
	1	86 mm sq.	R2AAB8100H	C	100	112	RS3A03□□〈30A〉	RS2A03□□〈30A〉
		86 mm sq.	R2AAB8100F	C	102	112	RS3A05□□〈50A〉	RS2A05□□〈50A〉
		100 mm sq.	R2AA10100F	C	102	112	RS3A05□□〈50A〉	RS2A05□□〈50A〉
	1.2	130 mm sq.	R2AA13120B	P	101	113	RS3A03□□〈30A〉	RS2A03□□〈30A〉
		130 mm sq.	R2AA13120L	P	102	113	RS3A05□□〈50A〉	RS2A05□□〈50A〉
		130 mm sq.	R2AA13120D	P	103	113	RS3A05□□〈50A〉	RS2A05□□〈50A〉
	1.8	130 mm sq.	R2AA13180H	P	103	113	RS3A05□□〈50A〉	RS2A05□□〈50A〉
		130 mm sq.	R2AA13180D	P	103	113	RS3A10□□〈100A〉	RS2A10□□〈100A〉
	2	130 mm sq.	R2AA13200L	P	103	114	RS3A05□□〈50A〉	RS2A05□□〈50A〉
		130 mm sq.	R2AA13200D	P	104	114	RS3A10□□〈100A〉	RS2A10□□〈100A〉
	3.5	180 mm sq.	R2AA18350L	P	104	105	RS3A10□□〈100A〉	RS2A10□□〈100A〉
		180 mm sq.	R2AA18350D	P	104	105	RS3A15□□〈150A〉	RS2A15□□〈150A〉
	4.5	180 mm sq.	R2AA18450H	P	104	105	RS3A15□□〈150A〉	RS2A15□□〈150A〉
	5	220 mm sq.	R2AA22500L	P	105	116	RS3A15□□〈150A〉	RS2A15□□〈150A〉
	5.5	180 mm sq.	R2AA18550R	P	105	105	RS3A15□□〈150A〉	RS2A15□□〈150A〉
		180 mm sq.	R2AA18550H	P	105	105	RS3A30□□〈300A〉	RS2A30□□〈300A〉
7	220 mm sq.	R2AA22700S	P	105	116	RS3A15□□〈150A〉	RS2A15□□〈150A〉	
7.5	180 mm sq.	R2AA18750H	P	106	105	RS3A30□□〈300A〉	RS2A30□□〈300A〉	
11	180 mm sq.	R2AA1811KR	P	106	105	RS3A30□□〈300A〉	RS2A30□□〈300A〉	
	220 mm sq.	R2AA2211KB	P	106	116	RS3A30□□〈300A〉	RS2A30□□〈300A〉	
15	220 mm sq.	R2AA2215KB	P	106	116	RS3A30□□〈300A〉	RS2A30□□〈300A〉	
20	220 mm sq.	R2AA2220KB	P	107	117	RS3W60□□〈600A〉	—	
30	275 mm sq.	R2AA2830KV	P	107	117	RS3W60□□〈600A〉	—	

*1: Values in parentheses are the output values for motors with brakes. With the optional oil seals, rated outputs of servo motors might be reduced to 80 to 95% of the values in the above table.

*2: Listed in the column are model numbers of amplifier units. Beside amplifier units, a motherboard and a power supply unit are required for operation. 15 A capacity amplifier is a 6-axis model, and 30 A capacity amplifier is a 4-axis model.

Servo amplifier			Servo motor	
R CANopen Interface type p. 67	R Built-in Positioning Function type p. 75	R Multi-axis Pulse Input type*2 p. 87	Model name (Partial model no.)	Rated output [kW]
*Not compatible with the battery-less optical absolute encoder HA035.				
—	RS1E01□□〈15A〉	RR1E01AAB〈15A〉	R2EA04003F	0.03
—	RS1E01□□〈15A〉	RR1E01AAB〈15A〉	R2EA04005F	0.05
—	RS1E01□□〈15A〉	RR1E01AAB〈15A〉	R2EA04008F	0.08
—	RS1E01□□〈15A〉	RR1E01AAB〈15A〉	R2EA06010F	0.1
—	RS1E03□□〈30A〉	RR1E03AAB〈30A〉	R2EA06020F	0.2
RS1A01□□〈15A〉	RS1A01□□〈15A〉	RR1A01AAB00〈15A〉	R2AA04003F	0.03
RS1A01□□〈15A〉	RS1A01□□〈15A〉	RR1A01AAB00〈15A〉	R2AA04005F	0.05
RS1A01□□〈15A〉	RS1A01□□〈15A〉	RR1A01AAB00〈15A〉	R2AA04010F	0.1 (0.09)*1
RS1A01□□〈15A〉	RS1A01□□〈15A〉	RR1A01AAB00〈15A〉	R2AA06010F	0.1
RS1A01□□〈15A〉	RS1A01□□〈15A〉	RR1A01AAB00〈15A〉	R2AA06020F	0.2
RS1A01□□〈15A〉	RS1A01□□〈15A〉	RR1A01AAB00〈15A〉	R2AA08020F	0.2
RS1A01□□〈15A〉	RS1A01□□〈15A〉	RR1A01AAB00〈15A〉	R2AA06040H	0.4 (0.36)*1
RS1A03□□〈30A〉	RS1A03□□〈30A〉	RR1A03AAB00〈30A〉	R2AA06040F	0.4
RS1A03□□〈30A〉	RS1A03□□〈30A〉	RR1A03AAB00〈30A〉	R2AA08040F	0.4
RS1A03□□〈30A〉	RS1A03□□〈30A〉	RR1A03AAB00〈30A〉	R2AA13050H	0.55
RS1A03□□〈30A〉	RS1A03□□〈30A〉	RR1A03AAB00〈30A〉	R2AA13050D	0.55
RS1A03□□〈30A〉	RS1A03□□〈30A〉	RR1A03AAB00〈30A〉	R2AA08075F	0.75
RS1A03□□〈30A〉	RS1A03□□〈30A〉	RR1A03AAB00〈30A〉	R2AA10075F	0.75
RS1A05□□〈50A〉	RS1A05□□〈50A〉	—	R2AAB8075F	1
RS1A03□□〈30A〉	RS1A03□□〈30A〉	RR1A03AAB00〈30A〉	R2AAB8100H	1
RS1A05□□〈50A〉	RS1A05□□〈50A〉	—	R2AAB8100F	1
RS1A05□□〈50A〉	RS1A05□□〈50A〉	—	R2AA10100F	1
RS1A03□□〈30A〉	RS1A03□□〈30A〉	RR1A03AAB00〈30A〉	R2AA13120B	1.2
RS1A05□□〈50A〉	RS1A05□□〈50A〉	—	R2AA13120L	1.2
RS1A05□□〈50A〉	RS1A05□□〈50A〉	—	R2AA13120D	1.2
RS1A05□□〈50A〉	RS1A05□□〈50A〉	—	R2AA13180H	1.8
—	RS1A10□□〈100A〉	—	R2AA13180D	1.8
RS1A05□□〈50A〉	RS1A05□□〈50A〉	—	R2AA13200L	2
—	RS1A10□□〈100A〉	—	R2AA13200D	2
—	RS1A10□□〈100A〉	—	R2AA18350L	3.5
—	RS1A15□□〈150A〉	—	R2AA18350D	3.5
—	RS1A15□□〈150A〉	—	R2AA18450H	4.5
—	RS1A15□□〈150A〉	—	R2AA22500L	5
—	RS1A15□□〈150A〉	—	R2AA18550R	5.5
—	RS1A30□□〈300A〉	—	R2AA18550H	5.5
—	RS1A15□□〈150A〉	—	R2AA22700S	7
—	RS1A30□□〈300A〉	—	R2AA18750H	7.5
—	RS1A30□□〈300A〉	—	R2AA1811KR	11
—	RS1A30□□〈300A〉	—	R2AA2211KB	11
—	RS1A30□□〈300A〉	—	R2AA2215KB	15
—	—	—	R2AA2220KB	20
—	—	—	R2AA2830KV	30

List of Compatible Servo Amplifiers and Servo Motors

Standard specification **C**...Output shaft: Straight, Oil seal: None, Connecting method: Cable

P...Output shaft: With key, Oil seal: Yes, Connecting method: cannon plug (15 kW or lower), Terminal block (20 kW or higher)

Analog/Pulse Input type							Servo amplifier	
Motor type	Rated output [kW]	Flange size	Model name (Partial model no.)	Standard specification	Page		R 3E Model Analog/Pulse Input type p. 35	R ADVANCED EtherCAT Interface type p. 55
					Specifications	Dimensions		
R1 Servo motor 200 V system Low inertia	5.5	180 mm sq.	R1AA18550H	P	108	118	RS3A30□□〈300A〉	RS2A30□□〈300A〉
	7.5	180 mm sq.	R1AA18750L	P	108	118	RS3A30□□〈300A〉	RS2A30□□〈300A〉
	11	180 mm sq.	R1AA1811KR	P	109	118	RS3A30□□〈300A〉	RS2A30□□〈300A〉
	15	180 mm sq.	R1AA1815KB	P	109	118	RS3A30□□〈300A〉	RS2A30□□〈300A〉
	21	220 mm sq.	R1AA2220KV	P	109	118	RS3W60□□〈600A〉	—
R5 Servo motor 200 V system Medium inertia	0.2	60 mm sq.	R5AA06020H	C	110	112	RS3A01□□〈10A〉	RS2A01□□〈15A〉
	0.2	60 mm sq.	R5AA06020F	C	111	112	RS3A02□□〈20A〉	RS2A01□□〈15A〉
	0.4 (0.38)*1	60 mm sq.	R5AA06040H	C	110	112	RS3A02□□〈20A〉	RS2A01□□〈15A〉
	0.4*1	60 mm sq.	R5AA06040F	C	111	112	RS3A02□□〈20A〉	RS2A03□□〈30A〉
	0.75 (0.71)*1	80 mm sq.	R5AA08075D	C	110	112	RS3A03□□〈30A〉	RS2A03□□〈30A〉
	0.75 (0.675)*1	80 mm sq.	R5AA08075F	C	111	112	RS3A03□□〈30A〉	RS2A03□□〈30A〉
Linear Servo motor 200 V system	Flat type with core		DS045CC1AN (Coil model no.)		142	142	RS3A03□□〈30A〉	—
	Dual magnet type with core		DD045CB4AN (Coil model no.)		143	143	RS3A10□□〈100A〉	—

*1: Values in parentheses are the output values for motors with brakes. With the optional oil seals, rated outputs of servo motors might be reduced to 80 to 95% of the values in the above table.

*2: Listed in the column are model numbers of amplifier units. Beside amplifier units, a motherboard and a power supply unit are required for operation. 15 A capacity amplifier is a 6-axis model, and 30 A capacity amplifier is a 4-axis model.

Servo amplifier			Servo motor	
R CANopen Interface type p. 67	R Built-in Positioning Function type p. 75	R Multi-axis Pulse Input type*2 p. 87	Model name (Partial model no.)	Rated output [kW]
*Not compatible with the battery-less optical absolute encoder HA035.				
—	RS1A30□□〈300A〉	—	R1AA18550H	5.5
—	RS1A30□□〈300A〉	—	R1AA18750L	7.5
—	RS1A30□□〈300A〉	—	R1AA1811KR	11
—	RS1A30□□〈300A〉	—	R1AA1815KB	15
—	—	—	R1AA2220KV	21
RS1A01□□〈15A〉	RS1A01□□〈15A〉	RR1A01AAB00〈15A〉	R5AA06020H	0.2
RS1A01□□〈15A〉	RS1A01□□〈15A〉	RR1A01AAB00〈15A〉	R5AA06020F	0.2
RS1A01□□〈15A〉	RS1A01□□〈15A〉	RR1A01AAB00〈15A〉	R5AA06040H	0.4 (0.38)*1
RS1A03□□〈30A〉	RS1A03□□〈30A〉	RR1A03AAB00〈30A〉	R5AA06040F	0.4*1
RS1A03□□〈30A〉	RS1A03□□〈30A〉	RR1A03AAB00〈30A〉	R5AA08075D	0.75 (0.71)*1
RS1A03□□〈30A〉	RS1A03□□〈30A〉	RR1A03AAB00〈30A〉	R5AA08075F	0.75 (0.675)*1
—	—	—	DS045CC1AN (Coil model no.)	
—	—	—	DD045CB4AN (Coil model no.)	

Standard Model Number List

For specifications on other models, contact us for details.

Input voltage **100 VAC**

Servo Amplifier R 3E Model Analog/Pulse Input type

Main circuit power supply	Control circuit power supply	Encoder type	General output	Internal regenerative resistor	Safe Torque Off function (without delay), tandem operation function	Amplifier capacity	Model no.	Page		
								Specifications	Dimensions	
100 VAC system 100 to 120 VAC single-phase	100 VAC system 100 to 120 VAC single-phase	Serial encoder	Sink (NPN)	No	No	10 A	RS3E01A0AL0	p. 44	p. 45	
						20 A	RS3E02A0AL0	p. 44	p. 45	
						30 A	RS3E03A0AL0	p. 44	p. 45	
						10 A	RS3E01A0AL2	p. 44	p. 45	
						20 A	RS3E02A0AL2	p. 44	p. 45	
						30 A	RS3E03A0AL2	p. 44	p. 45	
				Yes	No	10 A	RS3E01A0AA0	p. 44	p. 45	
						20 A	RS3E02A0AA0	p. 44	p. 45	
						30 A	RS3E03A0AA0	p. 44	p. 45	
						10 A	RS3E01A0AA2	p. 44	p. 45	
						20 A	RS3E02A0AA2	p. 44	p. 45	
						30 A	RS3E03A0AA2	p. 44	p. 45	
			Source (PNP)	No	No	10 A	RS3E01A0BL0	p. 44	p. 45	
						20 A	RS3E02A0BL0	p. 44	p. 45	
						30 A	RS3E03A0BL0	p. 44	p. 45	
						10 A	RS3E01A0BL2	p. 44	p. 45	
						20 A	RS3E02A0BL2	p. 44	p. 45	
						30 A	RS3E03A0BL2	p. 44	p. 45	
				Yes	No	No	10 A	RS3E01A0BA0	p. 44	p. 45
							20 A	RS3E02A0BA0	p. 44	p. 45
							30 A	RS3E03A0BA0	p. 44	p. 45
							10 A	RS3E01A0BA2	p. 44	p. 45
							20 A	RS3E02A0BA2	p. 44	p. 45
							30 A	RS3E03A0BA2	p. 44	p. 45

Servo Amplifier R ADVANCED MODEL EtherCAT Interface type

Main circuit power supply	Control circuit power supply	Encoder type	General output	Internal regenerative resistor	Safe Torque Off function	Amplifier capacity	Model no.	Page	
								Specifications	Dimensions
100 VAC system 100 to 115 VAC single-phase	100 VAC system 100 to 115 VAC single-phase	Serial encoder	Photo relay output	No	Yes (with delay circuit)	15 A	RS2E01A2HL5	p. 62	p. 63
						30 A	RS2E03A2HL5	p. 62	p. 63
				Yes		15 A	RS2E01A2HA5	p. 62	p. 63
						30 A	RS2E03A2HA5	p. 62	p. 63

Servo Amplifier R Built-in Positioning Function type

Main circuit power supply	Control circuit power supply	Encoder type	General output	Internal regenerative resistor	Safe Torque Off function	Amplifier capacity	Model no.	Page	
								Specifications	Dimensions
100 VAC system 100 to 115 VAC single-phase	100 VAC system 100 to 115 VAC single-phase	Serial encoder, Pulse encoder	Sink type (NPN)	No	No	15 A	RS1E01AC	p. 80	p. 82
						30 A	RS1E03AC	p. 80	p. 82
				Yes		15 A	RS1N01AC	p. 80	p. 82
						30 A	RS1N03AC	p. 80	p. 82

Servo Amplifier R Multi-axis Pulse Input type

Required number of amplifier units, a power supply unit, and a motherboard are used as a set. The maximum number of axes is 6 axes for 15 A, 4 axes for 30 A. The maximum capacity is 800 W.

Amplifier unit

Input power supply	Encoder type	General output	Safe Torque Off function	Amplifier capacity	Model no.	Page	
						Specifications	Dimensions
140 VDC	Serial encoder	Sink type (NPN)	No	15 A	RR1E01AAB00	p. 90	p. 91
				30 A	RR1E03AAB00	p. 90	p. 91

Power supply unit

Input power supply	Built-in regenerative resistor	Model no.	Page	
			Specifications	Dimensions
100 VAC	Yes	RRPEA00	p. 90	p. 91

Motherboard

Input power supply	The number of mounted amplifier units		Model no.
	15 A	30 A	
100 VAC	4	2	RRME400
	6	3	RRME600
	—	4	RRME800
	—	—	—

• Our standard servo amplifiers conform to UL, c-UL, and EN standards. R 3E Model and R ADVANCED MODEL EtherCAT Interface type have also acquired the KC mark.

Standard Model Number List For specifications on other models, contact us for details.

Input voltage **100 VAC**

R2 Servo Motor Small Capacity, Medium Inertia

Standard specifications Output shaft: straight, oil seal: none, connection: cable (no connector)

Rated output	Motor flange size	Protection code	Holding brake	CE and UL approved	Model no.		Page			
					Battery-less optical absolute encoder (Model No. HA035) Only the R 3E Model and R ADVANCED MODEL servo amplifiers are compatible.	Optical absolute encoder for incremental systems (Model No. PA035S)	Specifications	Dimensions		
30 W	40 mm sq.	IP67	No	No	R2EA04003FXR00	R2EA04003FXH00	p. 96	p. 112		
				Yes	R2EA04003FXR00M	R2EA04003FXH00M	p. 96	p. 112		
			Yes (24 VDC)	No	R2EA04003FCR00	R2EA04003FCH00	p. 96	p. 112		
				Yes	R2EA04003FCR00M	R2EA04003FCH00M	p. 96	p. 112		
			IP65	No	No	R2EA04003FXR03	R2EA04003FXH03	p. 96	p. 112	
					Yes	R2EA04003FXR03M	R2EA04003FXH03M	p. 96	p. 112	
		Yes (24 VDC)	No	R2EA04003FCR03	R2EA04003FCH03	p. 96	p. 112			
			Yes	R2EA04003FCR03M	R2EA04003FCH03M	p. 96	p. 112			
		50 W	40 mm sq.	IP67	No	No	R2EA04005FXR00	R2EA04005FXH00	p. 96	p. 112
						Yes	R2EA04005FXR00M	R2EA04005FXH00M	p. 96	p. 112
					Yes (24 VDC)	No	R2EA04005FCR00	R2EA04005FCH00	p. 96	p. 112
						Yes	R2EA04005FCR00M	R2EA04005FCH00M	p. 96	p. 112
IP65	No				No	R2EA04005FXR03	R2EA04005FXH03	p. 96	p. 112	
					Yes	R2EA04005FXR03M	R2EA04005FXH03M	p. 96	p. 112	
Yes (24 VDC)	No			R2EA04005FCR03	R2EA04005FCH03	p. 96	p. 112			
	Yes			R2EA04005FCR03M	R2EA04005FCH03M	p. 96	p. 112			
80 W	40 mm sq.			IP67	No	No	R2EA04008FXR00	R2EA04008FXH00	p. 96	p. 112
						Yes	R2EA04008FXR00M	R2EA04008FXH00M	p. 96	p. 112
					Yes (24 VDC)	No	R2EA04008FCR00	R2EA04008FCH00	p. 96	p. 112
						Yes	R2EA04008FCR00M	R2EA04008FCH00M	p. 96	p. 112
		IP65	No		No	R2EA04008FXR03	R2EA04008FXH03	p. 96	p. 112	
					Yes	R2EA04008FXR03M	R2EA04008FXH03M	p. 96	p. 112	
		Yes (24 VDC)	No	R2EA04008FCR03	R2EA04008FCH03	p. 96	p. 112			
			Yes	R2EA04008FCR03M	R2EA04008FCH03M	p. 96	p. 112			
		100 W	60 mm sq.	IP67	No	No	R2EA06010FXR00	R2EA06010FXH00	p. 97	p. 112
						Yes	R2EA06010FXR00M	R2EA06010FXH00M	p. 97	p. 112
					Yes (24 VDC)	No	R2EA06010FCR00	R2EA06010FCH00	p. 97	p. 112
						Yes	R2EA06010FCR00M	R2EA06010FCH00M	p. 97	p. 112
IP65	No				No	R2EA06010FXR03	R2EA06010FXH03	p. 97	p. 112	
					Yes	R2EA06010FXR03M	R2EA06010FXH03M	p. 97	p. 112	
Yes (24 VDC)	No			R2EA06010FCR03	R2EA06010FCH03	p. 97	p. 112			
	Yes			R2EA06010FCR03M	R2EA06010FCH03M	p. 97	p. 112			
200 W	60 mm sq.			IP67	No	No	R2EA06020FXR00	R2EA06020FXH00	p. 97	p. 112
						Yes	R2EA06020FXR00M	R2EA06020FXH00M	p. 97	p. 112
					Yes (24 VDC)	No	R2EA06020FCR00	R2EA06020FCH00	p. 97	p. 112
						Yes	R2EA06020FCR00M	R2EA06020FCH00M	p. 97	p. 112
		IP65	No		No	R2EA06020FXR03	R2EA06020FXH03	p. 97	p. 112	
					Yes	R2EA06020FXR03M	R2EA06020FXH03M	p. 97	p. 112	
		Yes (24 VDC)	No	R2EA06020FCR03	R2EA06020FCH03	p. 97	p. 112			
			Yes	R2EA06020FCR03M	R2EA06020FCH03M	p. 97	p. 112			

Note: With the optional oil seals, rated outputs of servo motors might be reduced to 80 to 95% of the values in the above table.

Standard Model Number List

For specifications on other models, contact us for details.

Input voltage **200 VAC**

Servo Amplifier R 3E Model Analog/Pulse Input type

Main circuit power supply	Control circuit power supply	Encoder type	General output	Internal regenerative resistor	Safe Torque Off function (without delay), tandem operation function	Amplifier capacity	Model no.	Page	
								Specifications	Dimensions
200 VAC system 200 to 240 VAC 3-phase (can be also used for single-phase with 50 A or lower.)	200 VAC system 200 to 240 VAC single-phase	Serial encoder	Sink (NPN)	No	No	10 A	RS3A01A0AL0	p. 44	p. 45
						20 A	RS3A02A0AL0	p. 44	p. 45
						30 A	RS3A03A0AL0	p. 44	p. 45
						50 A	RS3A05A0AL0	p. 44	p. 46
						100 A	RS3A10A0AL0	p. 44	p. 46
						150 A	RS3A15A0AL0	p. 44	p. 46
						300 A	RS3A30A0AL0	p. 44	p. 47
						600 A	RS3W60A0AM0	p. 44	p. 47
						10 A	RS3A01A0AL2	p. 44	p. 45
						20 A	RS3A02A0AL2	p. 44	p. 45
						30 A	RS3A03A0AL2	p. 44	p. 45
						50 A	RS3A05A0AL2	p. 44	p. 46
				100 A	RS3A10A0AL2	p. 44	p. 46		
				150 A	RS3A15A0AL2	p. 44	p. 46		
				300 A	RS3A30A0AL2	p. 44	p. 47		
				600 A	RS3W60A0AM2	p. 44	p. 47		
				10 A	RS3A01A0AA0	p. 44	p. 45		
				20 A	RS3A02A0AA0	p. 44	p. 45		
				30 A	RS3A03A0AA0	p. 44	p. 45		
				50 A	RS3A05A0AA0	p. 44	p. 46		
				100 A	RS3A10A0AA0	p. 44	p. 46		
				150 A	RS3A15A0AA0	p. 44	p. 46		
				10 A	RS3A01A0AA2	p. 44	p. 45		
				20 A	RS3A02A0AA2	p. 44	p. 45		
			30 A	RS3A03A0AA2	p. 44	p. 45			
			50 A	RS3A05A0AA2	p. 44	p. 46			
			100 A	RS3A10A0AA2	p. 44	p. 46			
			150 A	RS3A15A0AA2	p. 44	p. 46			
			10 A	RS3A01A0BL0	p. 44	p. 45			
			20 A	RS3A02A0BL0	p. 44	p. 45			
			30 A	RS3A03A0BL0	p. 44	p. 45			
			50 A	RS3A05A0BL0	p. 44	p. 46			
			100 A	RS3A10A0BL0	p. 44	p. 46			
			150 A	RS3A15A0BL0	p. 44	p. 46			
			300 A	RS3A30A0BL0	p. 44	p. 47			
			600 A	RS3W60A0BM0	p. 44	p. 47			
			10 A	RS3A01A0BL2	p. 44	p. 45			
			20 A	RS3A02A0BL2	p. 44	p. 45			
			30 A	RS3A03A0BL2	p. 44	p. 45			
			50 A	RS3A05A0BL2	p. 44	p. 46			
			100 A	RS3A10A0BL2	p. 44	p. 46			
			150 A	RS3A15A0BL2	p. 44	p. 46			
			300 A	RS3A30A0BL2	p. 44	p. 47			
			600 A	RS3W60A0BM2	p. 44	p. 47			
			10 A	RS3A01A0BA0	p. 44	p. 45			
			20 A	RS3A02A0BA0	p. 44	p. 45			
			30 A	RS3A03A0BA0	p. 44	p. 45			
			50 A	RS3A05A0BA0	p. 44	p. 46			
100 A	RS3A10A0BA0	p. 44	p. 46						
150 A	RS3A15A0BA0	p. 44	p. 46						
10 A	RS3A01A0BA2	p. 44	p. 45						
20 A	RS3A02A0BA2	p. 44	p. 45						
30 A	RS3A03A0BA2	p. 44	p. 45						
50 A	RS3A05A0BA2	p. 44	p. 46						
100 A	RS3A10A0BA2	p. 44	p. 46						
150 A	RS3A15A0BA2	p. 44	p. 46						

• Our standard servo amplifiers conform to UL, c-UL, and EN standards. R 3E Model and R ADVANCED MODEL EtherCAT Interface type have also acquired the KC mark.
 • The servo amplifiers above are for rotary servo motors. For servo amplifiers for linear servo motors, contact us for details.

Power Supply Unit for 600 A Servo Amplifier Used together with 600 A amplifier unit.

Model no.	Page (dimensions)
RS3PAA27000	p. 47

Standard Model Number List For specifications on other models, contact us for details.

Input voltage **200 VAC**

Servo Amplifier R ADVANCED MODEL EtherCAT Interface type

Main circuit power supply	Control circuit power supply	Encoder type	General output	Built-in regenerative resistor	Safe Torque Off function	Amplifier capacity	Model no.	Page	
								Specifications	Dimensions
200 VAC system 200 to 230 VAC 3-phase	200 VAC system 200 to 230 VAC single-phase	Serial encoder	Photo relay output	No	Yes (with delay circuit)	15 A	RS2A01A2HL5	p. 62	p. 63
						30 A	RS2A03A2HL5	p. 62	p. 63
						50 A	RS2A05A2HL5	p. 62	p. 63
						300 A	RS2A30A2HL5	p. 62	p. 64
				Yes	Yes (with delay circuit)	15 A	RS2A01A2HA5	p. 62	p. 63
						30 A	RS2A03A2HA5	p. 62	p. 63
						50 A	RS2A05A2HA5	p. 62	p. 63
						100 A	RS2A10A2HA5	p. 62	p. 64
150 A	RS2A15A2HA5	p. 62	p. 64						

Servo Amplifier R CANopen Interface type

Main circuit power supply	Control circuit power supply	Encoder type	General output	Built-in regenerative resistor	Safe Torque Off function	Amplifier capacity	Model no.	Page	
								Specifications	Dimensions
200 VAC system 200 to 230 VAC 3-phase	200 VAC system 200 to 230 VAC single-phase	Serial encoder	Sink (NPN)	No	No	15 A	RS1A01AL	p. 70	p. 72
						30 A	RS1A03AL	p. 70	p. 72
						50 A	RS1L05AL	p. 70	p. 72
				Yes	No	15 A	RS1L01AL	p. 70	p. 72
						30 A	RS1L03AL	p. 70	p. 72
						50 A	RS1A05AL	p. 70	p. 72
	24 VDC	Serial encoder	Sink (NPN)	No	No	15 A	RS1J01AL	p. 70	p. 72
						30 A	RS1J03AL	p. 70	p. 72
						50 A	RS1J05AL	p. 70	p. 72
				Yes	No	15 A	RS1K01AL	p. 70	p. 72
						30 A	RS1K03AL	p. 70	p. 72
						50 A	RS1K05AL	p. 70	p. 72
	200 VAC system 200 to 230 VAC single-phase	Serial encoder	Source (PNP)	No	No	15 A	RS1A01AU	p. 70	p. 72
						30 A	RS1A03AU	p. 70	p. 72
						50 A	RS1L05AU	p. 70	p. 72
				Yes	No	15 A	RS1L01AU	p. 70	p. 72
						30 A	RS1L03AU	p. 70	p. 72
						50 A	RS1A05AU	p. 70	p. 72
	24 VDC	Serial encoder	Source (PNP)	No	No	15 A	RS1J01AU	p. 70	p. 72
						30 A	RS1J03AU	p. 70	p. 72
						50 A	RS1J05AU	p. 70	p. 72
				Yes	No	15 A	RS1K01AU	p. 70	p. 72
						30 A	RS1K03AU	p. 70	p. 72
						50 A	RS1K05AU	p. 70	p. 72

• Our standard servo amplifiers conform to UL, c-UL, and EN standards. R 3E Model and R ADVANCED MODEL EtherCAT Interface type have also acquired the KC mark.

Standard Model Number List

Standard Model Number List

For specifications on other models, contact us for details.

Input voltage **200 VAC**

Servo Amplifier R Built-in Positioning Function type Interface: DIO type

Main circuit power supply	Control circuit power supply	Encoder type	General output	Internal regenerative resistor	Safe Torque Off function	Amplifier capacity	Model no.	Page	
								Specifications	Dimensions
200 VAC system 200 to 230 VAC 3-phase	200 VAC system 200 to 230 VAC single-phase	Serial encoder Pulse encoder	Sink (NPN)	No	No	15 A	RS1A01AC	p. 80	p. 82
						30 A	RS1A03AC	p. 80	p. 82
						50 A	RS1L05AC	p. 80	p. 82
						100 A	RS1L10AC	p. 80	p. 82
						150 A	RS1L15AC	p. 80	p. 82
						300 A	RS1A30AC	p. 80	p. 82
				Yes	No	15 A	RS1L01AC	p. 80	p. 82
						30 A	RS1L03AC	p. 80	p. 82
						50 A	RS1A05AC	p. 80	p. 82
						100 A	RS1A10AC	p. 80	p. 82
						150 A	RS1A15AC	p. 80	p. 82

Servo Amplifier R Multi-axis Pulse Input type

Required number of amplifier units, a power supply unit, and a motherboard are used as a set. The maximum number of axes is 6 axes for 15 A, 4 axes for 30 A. The maximum capacity is 2000W.

Amplifier unit

Input power supply	Encoder type	General output	Safe Torque Off function	Amplifier capacity	Model no.	Page	
						Specifications	Dimensions
280 VDC	Serial encoder	Sink (NPN)	No	15 A	RR1A01AAB00	p. 90	p. 91
				30 A	RR1A03AAB00	p. 90	p. 91

Power supply unit

Input power supply	Built-in regenerative resistor	Model no.	Page	
			Specifications	Dimensions
200 VAC	Yes	RRPAA00	p. 90	p. 91

Motherboard

Input power supply	The number of mounted amplifier units		Model no.
	15 A	30 A	
200 VAC	4	2	RRMA400
	6	3	RRMA600
	—	4	RRMA800

· Our standard servo amplifiers conform to UL, c-UL, and EN standards.

Standard Model Number List For specifications on other models, contact us for details.

Input voltage **200 VAC**

R2 Servo Motor Small Capacity, Medium Inertia

Standard specifications Output shaft: straight, oil seal: none, connection: cable (no connector)

Rated output	Motor flange size	Protection code	Holding brake	CE and UL approved	Model no.		Page		
					Battery-less optical absolute encoder (Model No. HA035) Only the R 3E Model and R ADVANCED MODEL servo amplifiers are compatible.	Optical absolute encoder for incremental systems (Model No. PA035S)	Specifications	Dimensions	
30 W	40 mm sq.	IP67	No	No	R2AA04003FXR00	R2AA04003FXH00	p. 98	p. 112	
				Yes	R2AA04003FXR00M	R2AA04003FXH00M	p. 98	p. 112	
			Yes (24 VDC)	No	R2AA04003FCR00	R2AA04003FCH00	p. 98	p. 112	
		IP65	No	Yes	R2AA04003FCR00M	R2AA04003FCH00M	p. 98	p. 112	
				Yes (24 VDC)	No	R2AA04003FXR03	R2AA04003FXH03	p. 98	p. 112
			Yes	R2AA04003FXR03M	R2AA04003FXH03M	p. 98	p. 112		
	50 W	40 mm sq.	IP67	No	No	R2AA04005FXR00	R2AA04005FXH00	p. 98	p. 112
					Yes	R2AA04005FXR00M	R2AA04005FXH00M	p. 98	p. 112
				Yes (24 VDC)	No	R2AA04005FCR00	R2AA04005FCH00	p. 98	p. 112
			IP65	No	Yes	R2AA04005FCR00M	R2AA04005FCH00M	p. 98	p. 112
					Yes (24 VDC)	No	R2AA04005FXR03	R2AA04005FXH03	p. 98
				Yes	R2AA04005FXR03M	R2AA04005FXH03M	p. 98	p. 112	
90 W	40 mm sq.	IP67	No	No	R2AA04010FCR00	R2AA04010FCH00	p. 98	p. 112	
				Yes	R2AA04010FCR00M6	R2AA04010FCH00M6	p. 98	p. 112	
			Yes (24 VDC)	No	R2AA04010FCR03	R2AA04010FCH03	p. 98	p. 112	
		IP65	No	Yes	R2AA04010FCR03M6	R2AA04010FCH03M6	p. 98	p. 112	
				Yes (24 VDC)	No	R2AA04010FXR00	R2AA04010FXH00	p. 98	p. 112
			Yes	R2AA04010FXR00M	R2AA04010FXH00M	p. 98	p. 112		
100 W	40 mm sq.	IP67	No	No	R2AA04010FXR03	R2AA04010FXH03	p. 98	p. 112	
				Yes	R2AA04010FXR03M	R2AA04010FXH03M	p. 98	p. 112	
		IP65	No	No	R2AA04010FCR03	R2AA04010FCH03	p. 98	p. 112	
				Yes	R2AA04010FCR03M	R2AA04010FCH03M	p. 98	p. 112	
	60 mm sq.	IP67	No	No	R2AA06010FXR00	R2AA06010FXH00	p. 98	p. 112	
				Yes	R2AA06010FXR00M	R2AA06010FXH00M	p. 98	p. 112	
			Yes (24 VDC)	No	R2AA06010FCR00	R2AA06010FCH00	p. 98	p. 112	
				Yes	R2AA06010FCR00M	R2AA06010FCH00M	p. 98	p. 112	
		IP65	No	No	R2AA06010FXR03	R2AA06010FXH03	p. 98	p. 112	
				Yes	R2AA06010FXR03M	R2AA06010FXH03M	p. 98	p. 112	
			Yes (24 VDC)	No	R2AA06010FCR03	R2AA06010FCH03	p. 98	p. 112	
				Yes	R2AA06010FCR03M	R2AA06010FCH03M	p. 98	p. 112	
200 W	60 mm sq.	IP67	No	No	R2AA06020FXR00	R2AA06020FXH00	p. 99	p. 112	
				Yes	R2AA06020FXR00M	R2AA06020FXH00M	p. 99	p. 112	
			Yes (24 VDC)	No	R2AA06020FCR00	R2AA06020FCH00	p. 99	p. 112	
		IP65	No	Yes	R2AA06020FCR00M	R2AA06020FCH00M	p. 99	p. 112	
				Yes (24 VDC)	No	R2AA06020FXR03	R2AA06020FXH03	p. 99	p. 112
			Yes	R2AA06020FXR03M	R2AA06020FXH03M	p. 99	p. 112		
	80 mm sq.	IP67	No	No	R2AA08020FXR00	R2AA08020FXH00	p. 99	p. 112	
				Yes	R2AA08020FXR00M	R2AA08020FXH00M	p. 99	p. 112	
			Yes (24 VDC)	No	R2AA08020FCR00	R2AA08020FCH00	p. 99	p. 112	
		IP65	No	Yes	R2AA08020FCR00M	R2AA08020FCH00M	p. 99	p. 112	
				Yes (24 VDC)	No	R2AA08020FXR03	R2AA08020FXH03	p. 99	p. 112
			Yes	R2AA08020FXR03M	R2AA08020FXH03M	p. 99	p. 112		
80 mm sq.	IP67	No	No	R2AA08020FCR03	R2AA08020FCH03	p. 99	p. 112		
			Yes	R2AA08020FCR03M	R2AA08020FCH03M	p. 99	p. 112		
		Yes (24 VDC)	No	R2AA08020FCR03	R2AA08020FCH03	p. 99	p. 112		
	IP65	No	No	R2AA08020FCR03M	R2AA08020FCH03M	p. 99	p. 112		
			Yes	R2AA08020FCR03M	R2AA08020FCH03M	p. 99	p. 112		
		Yes (24 VDC)	No	R2AA08020FCR03	R2AA08020FCH03	p. 99	p. 112		

Note: With the optional oil seals, rated outputs of servo motors might be reduced to 80 to 95% of the values in the above table.

Standard Model Number List

Standard Model Number List

For specifications on other models, contact us for details.

Input voltage **200 VAC**

R2 Servo Motor Small Capacity, Medium Inertia

Standard specifications Output shaft: straight, oil seal: none, connection: cable (no connector)

Rated output	Motor flange size	Protection code	Holding brake	CE and UL approved	Model no.		Page		
					Battery-less optical absolute encoder (Model No. HA035) Only the R 3E Model and R ADVANCED MODEL servo amplifiers are compatible.	Optical absolute encoder for incremental systems (Model No. PA035S)	Specifications	Dimensions	
360 W	60 mm sq.	IP67	Yes (24 VDC)	No	R2AA06040FCR00	R2AA06040FCH00	p. 99	p. 112	
				Yes	R2AA06040FCR00M6	R2AA06040FCH00M6	p. 99	p. 112	
				No	R2AA06040HCR00	R2AA06040HCH00	p. 99	p. 112	
				Yes	R2AA06040HCR00M6	R2AA06040HCH00M6	p. 99	p. 112	
		IP65		No	R2AA06040FCR03	R2AA06040FCH03	p. 99	p. 112	
				Yes	R2AA06040FCR03M6	R2AA06040FCH03M6	p. 99	p. 112	
				No	R2AA06040HCR03	R2AA06040HCH03	p. 99	p. 112	
				Yes	R2AA06040HCR03M6	R2AA06040HCH03M6	p. 99	p. 112	
400 W	60 mm sq.	IP67	No	No	R2AA06040FXR00	R2AA06040FXH00	p. 99	p. 112	
				Yes	R2AA06040FXR00M	R2AA06040FXH00M	p. 99	p. 112	
				No	R2AA06040HXR00	R2AA06040HXXH00	p. 99	p. 112	
				Yes	R2AA06040HXR00M	R2AA06040HXXH00M	p. 99	p. 112	
		IP65		No	R2AA06040FXR03	R2AA06040FXH03	p. 99	p. 112	
				Yes	R2AA06040FXR03M	R2AA06040FXH03M	p. 99	p. 112	
				No	R2AA06040HXR03	R2AA06040HXXH03	p. 99	p. 112	
				Yes	R2AA06040HXR03M	R2AA06040HXXH03M	p. 99	p. 112	
	80 mm sq.	IP67	No	No	R2AA08040FXR00	R2AA08040FXH00	p. 100	p. 112	
				Yes	R2AA08040FXR00M	R2AA08040FXH00M	p. 100	p. 112	
			Yes (24 VDC)	No	R2AA08040FCR00	R2AA08040FCH00	p. 100	p. 112	
				Yes	R2AA08040FCR00M	R2AA08040FCH00M	p. 100	p. 112	
		IP65	No	No	R2AA08040FXR03	R2AA08040FXH03	p. 100	p. 112	
				Yes	R2AA08040FXR03M	R2AA08040FXH03M	p. 100	p. 112	
			Yes (24 VDC)	No	R2AA08040FCR03	R2AA08040FCH03	p. 100	p. 112	
				Yes	R2AA08040FCR03M	R2AA08040FCH03M	p. 100	p. 112	
750 W	80 mm sq.	IP67	No	No	R2AA08075FXR00	R2AA08075FXH00	p. 100	p. 112	
				Yes	R2AA08075FXR00M	R2AA08075FXH00M	p. 100	p. 112	
				Yes (24 VDC)	No	R2AA08075FCR00	R2AA08075FCH00	p. 100	p. 112
					Yes	R2AA08075FCR00M	R2AA08075FCH00M	p. 100	p. 112
		IP65		No	No	R2AA08075FXR03	R2AA08075FXH03	p. 100	p. 112
					Yes	R2AA08075FXR03M	R2AA08075FXH03M	p. 100	p. 112
				Yes (24 VDC)	No	R2AA08075FCR03	R2AA08075FCH03	p. 100	p. 112
					Yes	R2AA08075FCR03M	R2AA08075FCH03M	p. 100	p. 112
	86 mm sq.	IP67	No	No	R2AAB8075FXR00	R2AAB8075FXH00	p. 102	p. 112	
				Yes	R2AAB8075FXR00M	R2AAB8075FXH00M	p. 102	p. 112	
			Yes (24 VDC)	No	R2AAB8075FCR00	R2AAB8075FCH00	p. 102	p. 112	
				Yes	R2AAB8075FCR00M	R2AAB8075FCH00M	p. 102	p. 112	
		IP65	No	No	R2AAB8075FXR03	R2AAB8075FXH03	p. 102	p. 112	
				Yes	R2AAB8075FXR03M	R2AAB8075FXH03M	p. 102	p. 112	
			Yes (24 VDC)	No	R2AAB8075FCR03	R2AAB8075FCH03	p. 102	p. 112	
				Yes	R2AAB8075FCR03M	R2AAB8075FCH03M	p. 102	p. 112	
100 mm sq.	IP67	No	No	R2AA10075FXR00	R2AA10075FXH00	p. 100	p. 112		
			Yes	R2AA10075FXR00M	R2AA10075FXH00M	p. 100	p. 112		
		Yes (24 VDC)	No	R2AA10075FCR00	R2AA10075FCH00	p. 100	p. 112		
			Yes	R2AA10075FCR00M	R2AA10075FCH00M	p. 100	p. 112		
		IP65	No	No	R2AA10075FXR03	R2AA10075FXH03	p. 100	p. 112	
				Yes	R2AA10075FXR03M	R2AA10075FXH03M	p. 100	p. 112	
	Yes (24 VDC)	No	No	R2AA10075FCR03	R2AA10075FCH03	p. 100	p. 112		
			Yes	R2AA10075FCR03M	R2AA10075FCH03M	p. 100	p. 112		

Standard Model Number List For specifications on other models, contact us for details.

Input voltage **200 VAC**

R2 Servo Motor Small Capacity, Medium Inertia

Standard specifications Output shaft: straight, oil seal: none, connection: cable (no connector)

Rated output	Motor flange size	Protection code	Holding brake	CE and UL approved	Model no.		Page	
					Battery-less optical absolute encoder (Model No. HA035) Only the R 3E Model and R ADVANCED MODEL servo amplifiers are compatible.	Optical absolute encoder for incremental systems (Model No. PA035S)	Specifications	Dimensions
1 kW	86 mm sq.	IP67	No	No	R2AAB8100FXR00	R2AAB8100FXH00	p. 102	p. 112
				Yes	R2AAB8100FXR00M	R2AAB8100FXH00M	p. 102	p. 112
			Yes (24 VDC)	No	R2AAB8100FCR00	R2AAB8100FCH00	p. 102	p. 112
				Yes	R2AAB8100FCR00M	R2AAB8100FCH00M	p. 102	p. 112
			No	No	R2AAB8100HXR00	R2AAB8100HXH00	p. 100	p. 112
				Yes	R2AAB8100HXR00M	R2AAB8100HXH00M	p. 100	p. 112
		Yes (24 VDC)	No	R2AAB8100HCR00	R2AAB8100HCH00	p. 100	p. 112	
			Yes	R2AAB8100HCR00M	R2AAB8100HCH00M	p. 100	p. 112	
		IP65	No	No	R2AAB8100FXR03	R2AAB8100FXH03	p. 102	p. 112
				Yes	R2AAB8100FXR03M	R2AAB8100FXH03M	p. 102	p. 112
			Yes (24 VDC)	No	R2AAB8100FCR03	R2AAB8100FCH03	p. 102	p. 112
				Yes	R2AAB8100FCR03M	R2AAB8100FCH03M	p. 102	p. 112
	No		No	R2AAB8100HXR03	R2AAB8100HXH03	p. 100	p. 112	
			Yes	R2AAB8100HXR03M	R2AAB8100HXH03M	p. 100	p. 112	
	Yes (24 VDC)	No	R2AAB8100HCR03	R2AAB8100HCH03	p. 100	p. 112		
		Yes	R2AAB8100HCR03M	R2AAB8100HCH03M	p. 100	p. 112		
	100 mm sq.	IP67	No	No	R2AA10100FXR00	R2AA10100FXH00	p. 102	p. 112
				Yes	R2AA10100FXR00M	R2AA10100FXH00M	p. 102	p. 112
			Yes (24 VDC)	No	R2AA10100FCR00	R2AA10100FCH00	p. 102	p. 112
				Yes	R2AA10100FCR00M	R2AA10100FCH00M	p. 102	p. 112
			No	No	R2AA10100FXR03	R2AA10100FXH03	p. 102	p. 112
				Yes	R2AA10100FXR03M	R2AA10100FXH03M	p. 102	p. 112
		Yes (24 VDC)	No	R2AA10100FCR03	R2AA10100FCH03	p. 102	p. 112	
			Yes	R2AA10100FCR03M	R2AA10100FCH03M	p. 102	p. 112	

Standard Model Number List

Standard Model Number List

For specifications on other models, contact us for details.

Input voltage **200 VAC**

R2 Servo Motor Medium Capacity, Medium Inertia

Standard specifications Output shaft: with key, oil seal: yes, connection: cannon plug (550 W to 15 kW), terminal block (20 kW or higher)

Rated output	Motor flange size	Protection code	Holding brake	CE and UL approved	Model no.		Page				
					Battery-less optical absolute encoder (Model No. HA035) Only the R 3E Model and R ADVANCED MODEL servo amplifiers are compatible.	Optical absolute encoder for incremental systems (Model No. PA035S)	Specifications	Dimensions			
550 W	130 mm sq.	IP65	No	No	R2AA13050HXR00	R2AA13050HXH00	p. 101	p. 113			
				Yes	R2AA13050HXR00M	R2AA13050HXH00M	p. 101	p. 113			
			Yes (24 VDC)	No	R2AA13050HCR00	R2AA13050HCH00	p. 101	p. 113			
				Yes	R2AA13050HCR00M	R2AA13050HCH00M	p. 101	p. 113			
			No	No	R2AA13050DXR00	R2AA13050DXH00	p. 101	p. 113			
				Yes	R2AA13050DXR00M	R2AA13050DXH00M	p. 101	p. 113			
			Yes (24 VDC)	No	R2AA13050DCR00	R2AA13050DCH00	p. 101	p. 113			
				Yes	R2AA13050DCR00M	R2AA13050DCH00M	p. 101	p. 113			
			1.2 kW	130 mm sq.	IP65	No	No	R2AA13120BXR00	R2AA13120BXH00	p. 101	p. 113
							Yes	R2AA13120BXR00M	R2AA13120BXH00M	p. 101	p. 113
						Yes (24 VDC)	No	R2AA13120BCR00	R2AA13120BCH00	p. 101	p. 113
							Yes	R2AA13120BCR00M	R2AA13120BCH00M	p. 101	p. 113
No	No	R2AA13120LXR00				R2AA13120LXH00	p. 102	p. 113			
	Yes	R2AA13120LXR00M				R2AA13120LXH00M	p. 102	p. 113			
Yes (24 VDC)	No	R2AA13120LCR00				R2AA13120LCH00	p. 102	p. 113			
	Yes	R2AA13120LCR00M				R2AA13120LCH00M	p. 102	p. 113			
No	No	R2AA13120DXR00				R2AA13120DXH00	p. 103	p. 113			
	Yes	R2AA13120DXR00M				R2AA13120DXH00M	p. 103	p. 113			
Yes (24 VDC)	No	R2AA13120DCR00				R2AA13120DCH00	p. 103	p. 113			
	Yes	R2AA13120DCR00M				R2AA13120DCH00M	p. 103	p. 113			
1.8 kW	130 mm sq.	IP65				No	No	R2AA13180HXR00	R2AA13180HXH00	p. 103	p. 113
							Yes	R2AA13180HXR00M	R2AA13180HXH00M	p. 103	p. 113
						Yes(24 VDC)	No	R2AA13180HCR00	R2AA13180HCH00	p. 103	p. 113
							Yes	R2AA13180HCR00M	R2AA13180HCH00M	p. 103	p. 113
						No	No	R2AA13180DXR00	R2AA13180DXH00	p. 103	p. 113
							Yes	R2AA13180DXR00M	R2AA13180DXH00M	p. 103	p. 113
			Yes(24 VDC)	No	R2AA13180DCR00	R2AA13180DCH00	p. 103	p. 113			
				Yes	R2AA13180DCR00M	R2AA13180DCH00M	p. 103	p. 113			
			2 kW	130 mm sq.	IP65	No	No	R2AA13200LXR00	R2AA13200LXH00	p. 103	p. 114
							Yes	R2AA13200LXR00M	R2AA13200LXH00M	p. 103	p. 114
						Yes (24 VDC)	No	R2AA13200LCR00	R2AA13200LCH00	p. 103	p. 114
							Yes	R2AA13200LCR00M	R2AA13200LCH00M	p. 103	p. 114
No	No	R2AA13200DXR00				R2AA13200DXH00	p. 104	p. 114			
	Yes	R2AA13200DXR00M				R2AA13200DXH00M	p. 104	p. 114			
Yes (24 VDC)	No	R2AA13200DCR00				R2AA13200DCH00	p. 104	p. 114			
	Yes	R2AA13200DCR00M				R2AA13200DCH00M	p. 104	p. 114			
3.5 kW	180 mm sq.	IP65				No	No	R2AA18350LXR00	R2AA18350LXH00	p. 104	p. 115
							Yes	R2AA18350LXR00M	R2AA18350LXH00M	p. 104	p. 115
						Yes (24 VDC)	No	R2AA18350LCR00	R2AA18350LCH00	p. 104	p. 115
							Yes	R2AA18350LCR00M	R2AA18350LCH00M	p. 104	p. 115
			No	No	R2AA18350DXR00	R2AA18350DXH00	p. 104	p. 115			
				Yes	R2AA18350DXR00M	R2AA18350DXH00M	p. 104	p. 115			
			Yes (24 VDC)	No	R2AA18350DCR00	R2AA18350DCH00	p. 104	p. 115			
				Yes	R2AA18350DCR00M	R2AA18350DCH00M	p. 104	p. 115			
			4.5 kW	180 mm sq.	IP65	No	No	R2AA18450HXR00	R2AA18450HXH00	p. 104	p. 115
							Yes	R2AA18450HXR00M	R2AA18450HXH00M	p. 104	p. 115
						Yes (24 VDC)	No	R2AA18450HCR00	R2AA18450HCH00	p. 104	p. 115
							Yes	R2AA18450HCR00M	R2AA18450HCH00M	p. 104	p. 115

Standard Model Number List For specifications on other models, contact us for details.

Input voltage **200 VAC**

R2 Servo Motor 200 V System, Medium Capacity, Medium Inertia

Standard specifications Output shaft: with key, oil seal: yes, connection: cannon plug (550 W to 15 kW), terminal block (20 kW or higher)

Rated output	Motor flange size	Protection code	Holding brake	CE and UL approved	Model no.		Page	
					Battery-less optical absolute encoder (Model No. HA035) Only the R 3E Model and R ADVANCED MODEL servo amplifiers are compatible.	Optical absolute encoder for incremental systems (Model No. PA035S)	Specifications	Dimensions
5 kW	220 mm sq.	IP65	No	No	R2AA22500LXR00	R2AA22500LXH00	p. 105	p. 116
				Yes	R2AA22500LXR00M	R2AA22500LXH00M	p. 105	p. 116
			Yes (24 VDC)	—	R2AA22500LCR00	R2AA22500LCH00	p. 105	p. 116
				Yes	R2AA22500LCR00M	R2AA22500LCH00M	p. 105	p. 116
5.5 kW	180 mm sq.	IP65	No	No	R2AA18550RXR00	R2AA18550RXH00	p. 105	p. 115
				Yes	R2AA18550RXR00M	R2AA18550RXH00M	p. 105	p. 115
			Yes (24 VDC)	No	R2AA18550RCR00	R2AA18550RCH00	p. 105	p. 115
				Yes	R2AA18550RCR00M	R2AA18550RCH00M	p. 105	p. 115
			No	No	R2AA18550HXR00	R2AA18550HXH00	p. 105	p. 115
				Yes	R2AA18550HXR00M	R2AA18550HXH00M	p. 105	p. 115
			Yes (24 VDC)	No	R2AA18550HCR00	R2AA18550HCH00	p. 105	p. 115
				Yes	R2AA18550HCR00M	R2AA18550HCH00M	p. 105	p. 115
7 kW	220 mm sq.	IP65	No	No	R2AA22700SXR00	R2AA22700SXH00	p. 105	p. 116
				Yes	R2AA22700SXR00M	R2AA22700SXH00M	p. 105	p. 116
			Yes (24 VDC)	No	R2AA22700SCR00	R2AA22700SCH00	p. 105	p. 116
				Yes	R2AA22700SCR00M	R2AA22700SCH00M	p. 105	p. 116
7.5 kW	180 mm sq.	IP65	No	No	R2AA18750HXR00	R2AA18750HXH00	p. 106	p. 115
				Yes	R2AA18750HXR00M	R2AA18750HXH00M	p. 106	p. 115
			Yes (24 VDC)	No	R2AA18750HCR00	R2AA18750HCH00	p. 106	p. 115
				Yes	R2AA18750HCR00M	R2AA18750HCH00M	p. 106	p. 115
11 kW	180 mm sq.	IP65	No	No	R2AA1811KRXR00	R2AA1811KRXH00	p. 106	p. 115
				Yes	R2AA1811KRXR00M	R2AA1811KRXH00M	p. 106	p. 115
			Yes (24 VDC)	No	R2AA1811KRCR00	R2AA1811KRCH00	p. 106	p. 115
				Yes	R2AA1811KRCR00M	R2AA1811KRCH00M	p. 106	p. 115
	220 mm sq.	IP65	No	No	R2AA2211KBXR00	R2AA2211KBXH00	p. 106	p. 116
				Yes	R2AA2211KBXR00M	R2AA2211KBXH00M	p. 106	p. 116
			Yes (24 VDC)	No	R2AA2211KBCR00	R2AA2211KBCH00	p. 106	p. 116
				Yes	R2AA2211KBCR00M	R2AA2211KBCH00M	p. 106	p. 116
15 kW	220 mm sq.	IP65	No	No	R2AA2215KBXR00	R2AA2215KBXH00	p. 106	p. 116
				Yes	R2AA2215KBXR00M	R2AA2215KBXH00M	p. 106	p. 116
			Yes (24 VDC)	No	R2AA2215KBCR00	R2AA2215KBCH00	p. 106	p. 116
				Yes	R2AA2215KBCR00M	R2AA2215KBCH00M	p. 106	p. 116
20 kW	220 mm sq.	IP65	No	No	R2AA2220KBXR00	R2AA2220KBXH00	p. 107	p. 117
				Yes	R2AA2220KBXR00M	R2AA2220KBXH00M	p. 107	p. 117
			Yes (24 VDC)	No	R2AA2220KBCR00	R2AA2220KBCH00	p. 107	p. 117
				Yes	R2AA2220KBCR00M	R2AA2220KBCH00M	p. 107	p. 117
30 kW	275 mm sq.	IP65	No	Preparing	R2AA2830KVXR00	R2AA2830KVXH00	p. 107	p. 117
					Yes (24 VDC)	R2AA2830KVCR00	R2AA2830KVCH00	p. 107

Standard Model Number List

Standard Model Number List

For specifications on other models, contact us for details.

Input voltage **200 VAC**

R1 Servo Motor 200 V System, Medium Capacity, Low Inertia

Standard specifications Output shaft: with key, oil seal: yes, connection: cannon plug (5.5 kW to 15 kW), terminal block (21 kW)

Rated output	Motor flange size	Protection code	Holding brake	CE and UL approved	Model no.		Page	
					Battery-less optical absolute encoder (Model No. HA035) Only the R 3E Model and R ADVANCED MODEL servo amplifiers are compatible.	Optical absolute encoder for incremental systems (Model No. PA035S)	Specifications	Dimensions
5.5 kW	180 mm sq.	IP65 (Excluding cooling fans)	No	No	R1AA18550HXR00	R1AA18550HXH00	p. 108	p. 118
				Yes	R1AA18550HXR00M	R1AA18550HXH00M	p. 108	p. 118
			Yes (24 VDC)	No	R1AA18550HCR00	R1AA18550HCH00	p. 108	p. 118
				Yes	R1AA18550HCR00M	R1AA18550HCH00M	p. 108	p. 118
7.5 kW	180 mm sq.		No	No	R1AA18750LXR00	R1AA18750LXH00	p. 108	p. 118
				Yes	R1AA18750LXR00M	R1AA18750LXH00M	p. 108	p. 118
			Yes (24 VDC)	No	R1AA18750LCR00	R1AA18750LCH00	p. 108	p. 118
				Yes	R1AA18750LCR00M	R1AA18750LCH00M	p. 108	p. 118
11 kW	180 mm sq.		No	No	R1AA1811KXR00	R1AA1811KRXH00	p. 109	p. 118
				Yes	R1AA1811KXR00M	R1AA1811KRXH00M	p. 109	p. 118
			Yes (24 VDC)	No	R1AA1811KCR00	R1AA1811KRCH00	p. 109	p. 118
				Yes	R1AA1811KCR00M	R1AA1811KRCH00M	p. 109	p. 118
15 kW	180 mm sq.	No	No	R1AA1815KBXR00	R1AA1815KBXH00	p. 109	p. 118	
			Yes	R1AA1815KBXR00M	R1AA1815KBXH00M	p. 109	p. 118	
		Yes (24 VDC)	No	R1AA1815KBCR00	R1AA1815KBCH00	p. 109	p. 118	
			Yes	R1AA1815KBCR00M	R1AA1815KBCH00M	p. 109	p. 118	
21 kW	220 mm sq.	No	No	R1AA2220KVXR00	R1AA2220KVXH00	p. 109	p. 118	
			Yes	R1AA2220KVXR00M	R1AA2220KVXH00M	p. 109	p. 118	

R5 Servo Motor Small Capacity, Medium Inertia

Standard specifications Output shaft: straight, oil seal: none, connecting: cable (no connector)

Rated output	Motor flange size	Protection code	Holding brake	CE and UL approved	Model no.		Page		
					Battery-less optical absolute encoder (Model No. HA035) Only the R 3E Model and R ADVANCED MODEL servo amplifiers are compatible.	Optical absolute encoder for incremental systems (Model No. PA035S)	Specifications	Dimensions	
200 W	60 mm sq.	IP65	No	No	R5AA06020HXR03	R5AA06020HXH03	p. 110	p. 112	
				Yes	R5AA06020HXR03M	R5AA06020HXH03M	p. 110	p. 112	
			Yes (24 VDC)	No	R5AA06020HCR03	R5AA06020HCH03	p. 110	p. 112	
				Yes	R5AA06020HCR03M	R5AA06020HCH03M	p. 110	p. 112	
			No	No	R5AA06020FXR03	R5AA06020FXH03	p. 111	p. 112	
				Yes	R5AA06020FXR03M	R5AA06020FXH03M	p. 111	p. 112	
			Yes (24 VDC)	No	R5AA06020FCR03	R5AA06020FCH03	p. 111	p. 112	
				Yes	R5AA06020FCR03M	R5AA06020FCH03M	p. 111	p. 112	
380 W	60 mm sq.		IP65	Yes (24 VDC)	No	R5AA06040HCR03	R5AA06040HCH03	p. 110	p. 112
					Yes	R5AA06040HCR03M	R5AA06040HCH03M	p. 110	p. 112
400 W	60 mm sq.		IP65	No	No	R5AA06040HXR03	R5AA06040HXH03	p. 110	p. 112
					Yes	R5AA06040HXR03M	R5AA06040HXH03M	p. 110	p. 112
		No		No	R5AA06040FXR03	R5AA06040FXH03	p. 111	p. 112	
				Yes	R5AA06040FXR03M	R5AA06040FXH03M	p. 111	p. 112	
		Yes (24 VDC)		No	R5AA06040FCR03	R5AA06040FCH03	p. 111	p. 112	
				Yes	R5AA06040FCR03M	R5AA06040FCH03M	p. 111	p. 112	
675 W	80 mm sq.	IP65		Yes (24 VDC)	No	R5AA08075FCR03	R5AA08075FCH03	p. 111	p. 112
					Yes	R5AA08075FCR03M	R5AA08075FCH03M	p. 111	p. 112
710 W	80 mm sq.	IP65		Yes (24 VDC)	No	R5AA08075DCR03	R5AA08075DCH03	p. 110	p. 112
					Yes	R5AA08075DCR03M	R5AA08075DCH03M	p. 110	p. 112
750 W	80 mm sq.	IP65		No	No	R5AA08075DXR03	R5AA08075DXH03	p. 110	p. 112
					Yes	R5AA08075DXR03M	R5AA08075DXH03M	p. 110	p. 112
			No	No	R5AA08075FXR03	R5AA08075FXH03	p. 111	p. 112	
				Yes	R5AA08075FXR03M	R5AA08075FXH03M	p. 111	p. 112	

Note: With the optional oil seals, rated outputs of servo motors might be reduced to 80 to 95% of the values in the above table.

Standard Model Number List

For specifications on other models, contact us for details.

Option

R 3E Model			
Model no.	Category	Remarks	Page
AL-00385594	Connector to connect servo amplifier (10 to 50 A)	Single CN1	p. 122
AL-00632607	Connector to connect servo amplifier (10 to 50 A)	Single EN1 and EN2	p. 122
AL-00686902-01	Connector to connect servo amplifier (10 to 50 A)	Single CNA	p. 122
AL-Y0004079-01	Connector to connect servo amplifier (10 to 50 A)	Single CNB	p. 122
AL-00718251-01	Connector to connect servo amplifier (10 to 50 A)	Single CN4	p. 122
AL-00718252-01	Connector to connect servo amplifier (10 to 50 A)	Single CN4	p. 122
AL-00723282	Connector to connect servo amplifier (10 to 50 A)	Connector set	p. 122
AL-00723284	Connector to connect servo amplifier (10 to 50 A)	Connector set	p. 122
AL-00723286	Connector to connect servo amplifier (10 to 50 A)	Connector set	p. 122
AL-00723288	Connector to connect servo amplifier (10 to 50 A)	Connector set	p. 122
AL-00723290	Connector to connect servo amplifier (10 to 50 A)	Connector set	p. 122
AL-00696037	Connector to connect servo amplifier (10 to 50 A)	Connector set	p. 122
AL-00723155	Connector to connect servo amplifier (10 to 50 A)	Connector set	p. 122
AL-00723156	Connector to connect servo amplifier (10 to 50 A)	Connector set	p. 122
AL-00723157	Connector to connect servo amplifier (10 to 50 A)	Connector set	p. 122
AL-00723158	Connector to connect servo amplifier (10 to 50 A)	Connector set	p. 122
AL-00723159	Connector to connect servo amplifier (10 to 50 A)	Connector set	p. 122
AL-00385594	Connector to connect servo amplifier (100 to 300 A)	Single CN1	p. 123
AL-00632607	Connector to connect servo amplifier (100 to 300 A)	Single EN1 and EN2	p. 123
AL-Y0005159-01	Connector to connect servo amplifier (100 to 600 A)	Single CNA	pp. 123, 124
AL-00718251-01	Connector to connect servo amplifier (100 to 600 A)	Single CN4	pp. 123, 124
AL-00718252-01	Connector to connect servo amplifier (100 to 600 A)	Single CN4	pp. 123, 124
AL-00751448	Connector to connect servo amplifier (100 to 300 A)	Connector set	p. 123
AL-00751450	Connector to connect servo amplifier (100 to 300 A)	Connector set	p. 123
AL-00723290	Connector to connect servo amplifier (100 to 300 A)	Connector set	p. 123
AL-00751452	Connector to connect servo amplifier (100 to 300 A)	Connector set	p. 123
AL-00751454	Connector to connect servo amplifier (100 to 300 A)	Connector set	p. 123
AL-00723159	Connector to connect servo amplifier (100 to 300 A)	Connector set	p. 123
AL-00608710	Connector to connect servo amplifier (600 A)	Single CN9	p. 124
AL-00385594	Connector to connect servo amplifier (600 A)	Single CN1	p. 124
AL-00632607	Connector to connect servo amplifier (600 A)	Single EN1 and EN2	p. 124
AL-Y0004079-01	Connector to connect servo amplifier (600 A)	Single CNB	p. 124
AL-Y0011185-01	Connector to connect servo amplifier (600 A)	Single CN8	p. 124
AL-00892848	Connector to connect servo amplifier (600 A)	Connector set	p. 124
AL-00892850	Connector to connect servo amplifier (600 A)	Connector set	p. 124
AL-00723290	Connector to connect servo amplifier (600 A)	Connector set	p. 124
AL-00892854	Connector to connect servo amplifier (600 A)	Connector set	p. 124
AL-00892856	Connector to connect servo amplifier (600 A)	Connector set	p. 124
AL-00892858	Connector to connect servo amplifier (600 A)	Connector set	p. 124
AL-00723159	Connector to connect servo amplifier (600 A)	Connector set	p. 124
AL-00892852	Connector to connect servo amplifier (600 A)	Connector set	p. 124
AL-00918125-01	Copper bar to connect servo amplifier units (600 A)		p. 124
AL-00917284	Cable to connect servo amplifier units (600 A)		p. 124
AL-00880390-01	Front mounting brackets (10 to 30 A)		p. 134
AL-00880391-01	Front mounting brackets (50 A)		p. 134
AL-00907039-01	Front mounting brackets (100 A, 150 A)		p. 134
AL-00907040-01	Front mounting brackets (300 A)		p. 134
AL-00880402-01	Battery box		p. 132
AL-00879511-01	Battery for battery box (Lithium battery)		p. 132
AL-00896515-01	USB communication cable for setup software	1.0 m	p. 131
AL-00896515-02	USB communication cable for setup software	2.0 m	p. 131
AL-00911582-01	Communication cable between amplifiers for tandem operation	0.2 m	p. 131
AL-00911582-02	Communication cable between amplifiers for tandem operation	3.0 m	p. 131

R ADVANCED			
Model no.	Category	Remarks	Page
AL-00632607	Connector to connect servo amplifier (15 to 50 A)	Single EN1 and EN2	p. 125
AL-00686902-01	Connector to connect servo amplifier (15 to 50 A)	Single CNA	p. 125
AL-Y0004079-01	Connector to connect servo amplifier (15 to 50 A)	Single CNB	p. 125
AL-00718252-01	Connector to connect servo amplifier (15 to 50 A)	Single CN1	p. 125
AL-00849548-02	Connector to connect servo amplifier (15 to 50 A)	Single CN1	p. 125
AL-00842383	Connector to connect servo amplifier (15 to 50 A)	Single CN2	p. 125
AL-00887324	Connector to connect servo amplifier (15 to 50 A)	Connector set	p. 125
AL-00887322	Connector to connect servo amplifier (15 to 50 A)	Connector set	p. 125
AL-00887328	Connector to connect servo amplifier (15 to 50 A)	Connector set	p. 125
AL-00887326	Connector to connect servo amplifier (15 to 50 A)	Connector set	p. 125
AL-00632607	Connector to connect servo amplifier (100 to 300 A)	Single EN1 and EN2	p. 125
AL-Y0005159-01	Connector to connect servo amplifier (100 to 300 A)	Single CNA	p. 125
AL-00718252-01	Connector to connect servo amplifier (100 to 300 A)	Single CN1	p. 125
AL-00849548-02	Connector to connect servo amplifier (100 to 300 A)	Single CN1	p. 125
AL-00842383	Connector to connect servo amplifier (100 to 300 A)	Single CN2	p. 125
AL-00887325	Connector to connect servo amplifier (100 to 300 A)	Connector set	p. 125
AL-00887329	Connector to connect servo amplifier (100 to 300 A)	Connector set	p. 125
AL-00689703-01	Communication cable for setup software	2.85 m	p. 131
AL-00736863-01	Front mounting brackets (15 A, 30 A)		p. 136
AL-00736864-01	Front mounting brackets (50 A)		p. 136
AL-00828413-01	Front mounting brackets (300 A)		p. 136

R			
Model no.	Category	Remarks	Page
AL-00608710	Connector to connect servo amplifier (CANopen interface type)	Single CN1	p. 126
AL-00385596	Connector to connect servo amplifier (CANopen interface type)	Single CN2	p. 126
AL-00329461-01	Connector to connect servo amplifier (CANopen interface type)	Single CNA	p. 126
AL-Y0000988-01	Connector to connect servo amplifier (CANopen interface type)	Single CNB	p. 126
AL-00329458-01	Connector to connect servo amplifier (CANopen interface type)	Single CNC	p. 126
AL-00661731	Connector to connect servo amplifier (CANopen interface type)	Connector set	p. 126
AL-00661729	Connector to connect servo amplifier (CANopen interface type)	Connector set	p. 126
AL-00608710	Connector to connect servo amplifier (CANopen interface type)	Single CN1	p. 126
AL-00385596	Connector to connect servo amplifier (CANopen interface type)	Single CN2	p. 126
AL-Y0000988-02	Connector to connect servo amplifier (CANopen interface type)	Single CNA	p. 126
AL-00329460-01	Connector to connect servo amplifier (CANopen interface type)	Single CNB	p. 126
AL-00329458-01	Connector to connect servo amplifier (CANopen interface type)	Single CNC	p. 126
AL-00661784	Connector to connect servo amplifier (CANopen interface type)	Connector set	p. 126
AL-00661729	Connector to connect servo amplifier (CANopen interface type)	Connector set	p. 126
AL-00385594	Connector to connect servo amplifier (Built-in positioning function type)	Single CN1	p. 127
AL-00385596	Connector to connect servo amplifier (Built-in positioning function type)	Single CN2	p. 127
AL-00329461-01	Connector to connect servo amplifier (Built-in positioning function type)	Single CNA	p. 127
AL-Y0000988-01	Connector to connect servo amplifier (Built-in positioning function type)	Single CNB	p. 127
AL-00329458-01	Connector to connect servo amplifier (Built-in positioning function type)	Single CNC	p. 127
AL-00393603	Connector to connect servo amplifier (Built-in positioning function type)	Connector set	p. 127
AL-00292309	Connector to connect servo amplifier (Built-in positioning function type)	Connector set	p. 127
AL-00385594	Connector to connect servo amplifier (Built-in positioning function type)	Single CN1	p. 127
AL-00385596	Connector to connect servo amplifier (Built-in positioning function type)	Single CN2	p. 127
AL-00329461-02	Connector to connect servo amplifier (Built-in positioning function type)	Single CNA	p. 127
AL-Y0000988-01	Connector to connect servo amplifier (Built-in positioning function type)	Single CNB	p. 127
AL-00329458-01	Connector to connect servo amplifier (Built-in positioning function type)	Single CNC	p. 127
AL-00492384	Connector to connect servo amplifier (Built-in positioning function type)	Connector set	p. 127
AL-00292309	Connector to connect servo amplifier (Built-in positioning function type)	Connector set	p. 127
AL-Y0004290-02	Connector to connect servo amplifier (Built-in positioning function type)	Single CN1	p. 127
AL-Y0003305-01	Connector to connect servo amplifier (Multi-axis pulse input type)	Single CN1	p. 128
AL-00632604	Connector to connect servo amplifier (Multi-axis pulse input type)	Single CNC	p. 128
AL-00632600	Connector to connect servo amplifier (Multi-axis pulse input type)	Single CNA	p. 128
AL-00632602	Connector to connect servo amplifier (Multi-axis pulse input type)	Single CNB	p. 128
AL-00385594	Connector to connect servo amplifier (Multi-axis pulse input type)	Single CN1A and CN1B	p. 128
AL-00632611	Connector to connect servo amplifier (Multi-axis pulse input type)	Connector set	p. 128
AL-00632609	Connector to connect servo amplifier (Multi-axis pulse input type)	Connector set	p. 128
AL-00490833-01	Communication cable for setup software	2.85 m	p. 131
AL-00494635-01	Battery (Lithium battery)		p. 132
AL-00582791-01	Mounting brackets (Built-in positioning function type)		p. 137
AL-00582792-01	Mounting brackets (Built-in positioning function type)		p. 137
AL-00582788-01	Mounting brackets (Built-in positioning function type)		p. 137
AL-00582789-01	Mounting brackets (Built-in positioning function type)		p. 137
AL-00582790-01	Mounting brackets (Built-in positioning function type)		p. 137

R 3E Model		R ADVANCED	
Model no.	Category	Remarks	Page
AL-00731792-01	Encoder extension cable with battery	With connectors on both ends	p. 132
AL-00697960-□□	Encoder extension cable with battery	With a connector on one end	p. 132
AL-00697958-01	Battery for encoder extension cable (Lithium battery)		p. 132
Q-MON-3	Analog monitor monitor box		p. 133
AL-00690525-01	Analog monitor dedicated cable		p. 133

R 3E Model		R ADVANCED		R	
Model no.	Category	Remarks	Page	Model no.	Category
REGIST-080W100B	External regenerative resistor		p. 133	REGIST-080W50B	External regenerative resistor
REGIST-080W50B	External regenerative resistor		p. 133	REGIST-122W100B	External regenerative resistor
REGIST-122W100B	External regenerative resistor		p. 133	REGIST-122W50B	External regenerative resistor
REGIST-122W50B	External regenerative resistor		p. 133	REGIST-220W20B	External regenerative resistor
REGIST-220W20B	External regenerative resistor		p. 133	REGIST-220W50B	External regenerative resistor
REGIST-220W50B	External regenerative resistor		p. 133	REGIST-220W100B	External regenerative resistor
REGIST-220W100B	External regenerative resistor		p. 133	REGIST-500CW20B	External regenerative resistor
REGIST-500CW20B	External regenerative resistor		p. 133	REGIST-500CW14B	External regenerative resistor
REGIST-500CW14B	External regenerative resistor		p. 133	REGIST-500CW10B	External regenerative resistor
REGIST-500CW10B	External regenerative resistor		p. 133	REGIST-500CW7B	External regenerative resistor
REGIST-500CW7B	External regenerative resistor		p. 133		

• For connectors to connect motors, refer to p. 130. For servo motor extension cables and for servo motors with extension cable connectors, refer to p. 138.

Standard Model Number List

Standard Model Number List

For specifications on other models, contact us for details.

Input voltage **200 VAC** Made in The Philippines

The products in this page are made in Philippines. They can be delivered to you faster.

Servo Amplifier R 3E Model Analog/Pulse Input type

Main circuit power supply	Control circuit power supply	Encoder type	General output	Built-in regenerative resistor	Safe Torque Off function (no delay), Tandem operation function	Amplifier capacity	Model no.	Page	
								Specifications	External dimensions
200 VAC system 200 to 240 VAC 3-phase (can be also used for single-phase with 50 A or lower.)	200 VAC system 200 to 240 VAC Single phase	Serial encoder	Sink type (NPN)	—	—	10A	RS3A01A0AL0W00	p. 44	p. 45
						20A	RS3A02A0AL0W00	p. 44	p. 45
						30A	RS3A03A0AL0W00	p. 44	p. 45
						50A	RS3A05A0AL0W00	p. 44	p. 45
						10A	RS3A01A0AA0W00	p. 44	p. 46
						20A	RS3A02A0AA0W00	p. 44	p. 45
						30A	RS3A03A0AA0W00	p. 44	p. 45
						50A	RS3A05A0AA0W00	p. 44	p. 46

Servo Amplifier R ADVANCED MODEL EtherCAT Interface type

Main circuit power supply	Control circuit power supply	Encoder type	General output	Built-in regenerative resistor	Safe Torque Off function	Amplifier capacity	Model no.	Page	
								Specifications	External dimensions
200 VAC system 200 to 230 VAC 3-phase	200 VAC system 200 to 230 VAC Single phase	Serial encoder	Photo relay output	Yes	Yes (with delay circuit)	15A	RS2A01A2HA5W00	p. 62	p. 63
						30A	RS2A03A2HA5W00	p. 62	p. 63
						50A	RS2A05A2HA5W00	p. 62	p. 63

• Our standard servo amplifiers conform to UL, c-UL, and EN standards. R 3E Model and R ADVANCED MODEL EtherCAT Interface type have also acquired the KC mark.

R2 Servo Motor 200 V System, Small Capacity, Medium Inertia

Rated output	Motor flange size	Protection code	Holding brake	CE and UL approved	Encoder	Output shaft	Oil seal	Model no.	Page	
									Specifications	Dimensions
85 W	40 mm sq.	IP67	No	No	Battery-backup method absolute encoder	With key	Yes	R2AA04010FXP29	p. 98	p. 112
			Yes (24 VDC)	No	Battery-backup method absolute encoder	With key	Yes	R2AA04010FCP29	p. 98	p. 112
90 W	40 mm sq.	IP67	Yes (24 VDC)	No	Battery-backup method absolute encoder	Round	No	R2AA04010FCP00	p. 98	p. 112
				No	Battery-backup method absolute encoder	With key	No	R2AA04010FCP1C	p. 98	p. 112
				No	Absolute encoder for incremental system	Round	No	R2AA04010FCH00	p. 98	p. 112
				Yes	Battery-backup method absolute encoder	Round	No	R2AA04010FCP00M6	p. 98	p. 112
				Yes	Battery-backup method absolute encoder	With key	No	R2AA04010FCP1CM6	p. 98	p. 112
				Yes	Absolute encoder for incremental system	Round	No	R2AA04010FCH00M6	p. 98	p. 112
				Yes	Absolute encoder for incremental system	With key	No	R2AA04010FCH1CM6	p. 98	p. 112
				Yes	Absolute encoder for incremental system	With key	No	R2AA04010FCH1CM6	p. 98	p. 112
100 W	40 mm sq.	IP67	No	No	Battery-backup method absolute encoder	Round	No	R2AA04010FXP00	p. 98	p. 112
				No	Battery-backup method absolute encoder	With key	No	R2AA04010FXP1C	p. 98	p. 112
				No	Absolute encoder for incremental system	Round	No	R2AA04010FXH00	p. 98	p. 112
				No	Absolute encoder for incremental system	With key	No	R2AA04010FXH1C	p. 98	p. 112
				Yes	Absolute encoder for incremental system	Round	No	R2AA04010FXH00M	p. 98	p. 112
				Yes	Absolute encoder for incremental system	With key	No	R2AA04010FXH1CM	p. 98	p. 112
200 W	60 mm sq.	IP67	No	No	Battery-backup method absolute encoder	Round	No	R2AA06020FXP00	p. 99	p. 112
				No	Battery-backup method absolute encoder	With key	No	R2AA06020FXP11	p. 99	p. 112
				No	Battery-backup method absolute encoder	With key	Yes	R2AA06020FXP29	p. 99	p. 112
				No	Absolute encoder for incremental system	Round	No	R2AA06020FXH00	p. 99	p. 112
				No	Absolute encoder for incremental system	With key	No	R2AA06020FXH11	p. 99	p. 112
				Yes	Battery-backup method absolute encoder	Round	No	R2AA06020FXP00M	p. 99	p. 112
				Yes	Battery-backup method absolute encoder	With key	No	R2AA06020FXP11M	p. 99	p. 112
				Yes	Absolute encoder for incremental system	Round	No	R2AA06020FXH00M	p. 99	p. 112
				Yes	Absolute encoder for incremental system	With key	No	R2AA06020FXH11M	p. 99	p. 112
				Yes	Absolute encoder for incremental system	With key	No	R2AA06020FCH00M	p. 99	p. 112
				Yes	Absolute encoder for incremental system	With key	No	R2AA06020FCH11M	p. 99	p. 112
				Yes	Absolute encoder for incremental system	With key	No	R2AA06020FCH11M	p. 99	p. 112
			Yes (24 VDC)	No	Battery-backup method absolute encoder	Round	No	R2AA06020FCP00	p. 99	p. 112
				No	Battery-backup method absolute encoder	With key	No	R2AA06020FCP11	p. 99	p. 112
				No	Battery-backup method absolute encoder	With key	Yes	R2AA06020FCP29	p. 99	p. 112
				No	Absolute encoder for incremental system	Round	No	R2AA06020FCH00	p. 99	p. 112
				No	Absolute encoder for incremental system	With key	No	R2AA06020FCH11	p. 99	p. 112
				Yes	Battery-backup method absolute encoder	Round	No	R2AA06020FCP00M	p. 99	p. 112
Yes	Battery-backup method absolute encoder	With key	No	R2AA06020FCP11M	p. 99	p. 112				
Yes	Absolute encoder for incremental system	Round	No	R2AA06020FCH00M	p. 99	p. 112				
Yes	Absolute encoder for incremental system	With key	No	R2AA06020FCH11M	p. 99	p. 112				

Standard Model Number List For specifications on other models, contact us for details.

Input voltage **200 VAC** Made in The Philippines

The products in this page are made in the Philippines. They can be delivered to you faster.

R2 Servo Motor 200 V System, Small Capacity, Medium Inertia

Rated output	Motor flange size	Protection code	Holding brake	CE and UL approved	Encoder	Output shaft	Oil seal	Model no.	Page	
									Specifications	Dimensions
320 W	60 mm sq.	IP67	No	No	Battery-backup method absolute encoder	With key	Yes	R2AA06040FXP29	p. 99	p. 112
				No	Absolute encoder for incremental system	Round	Yes	R2AA06040FXH01	p. 99	p. 112
			Yes (24 VDC)	No	Battery-backup method absolute encoder	With key	Yes	R2AA06040FCP29	p. 99	p. 112
				No	Absolute encoder for incremental system	Round	Yes	R2AA06040FCH01	p. 99	p. 112
360 W	60 mm sq.	IP67	Yes (24 VDC)	No	Battery-backup method absolute encoder	Round	No	R2AA06040FCP00	p. 99	p. 112
				No	Battery-backup method absolute encoder	With key	No	R2AA06040FCP11	p. 99	p. 112
				No	Absolute encoder for incremental system	Round	No	R2AA06040FCH00	p. 99	p. 112
				No	Absolute encoder for incremental system	With key	No	R2AA06040FCH11	p. 99	p. 112
				Yes	Battery-backup method absolute encoder	Round	No	R2AA06040FCP00M6	p. 99	p. 112
				Yes	Absolute encoder for incremental system	Round	No	R2AA06040FCH00M6	p. 99	p. 112
				Yes	Absolute encoder for incremental system	With key	No	R2AA06040FCH11M6	p. 99	p. 112
400 W	60 mm sq.	IP67	No	No	Battery-backup method absolute encoder	Round	No	R2AA06040FXP00	p. 99	p. 112
				No	Battery-backup method absolute encoder	With key	No	R2AA06040FXP11	p. 99	p. 112
				No	Absolute encoder for incremental system	Round	No	R2AA06040FXH00	p. 99	p. 112
				No	Absolute encoder for incremental system	With key	No	R2AA06040FXH11	p. 99	p. 112
				Yes	Battery-backup method absolute encoder	Round	No	R2AA06040FXP00M	p. 99	p. 112
				Yes	Battery-backup method absolute encoder	With key	No	R2AA06040FXP11M	p. 99	p. 112
				Yes	Absolute encoder for incremental system	Round	No	R2AA06040FXH00M	p. 99	p. 112
				Yes	Absolute encoder for incremental system	With key	No	R2AA06040FXH11M	p. 99	p. 112
675 W	80 mm sq.	IP67	No	No	Battery-backup method absolute encoder	With key	Yes	R2AA08075FXP29	p. 100	p. 112
				Yes	Absolute encoder for incremental system	With key	Yes	R2AA08075FXH29M6	p. 100	p. 112
			Yes (24 VDC)	No	Battery-backup method absolute encoder	Round	Yes	R2AA08075FCP01	p. 100	p. 112
				No	Battery-backup method absolute encoder	With key	Yes	R2AA08075FCP29	p. 100	p. 112
				No	Absolute encoder for incremental system	Round	Yes	R2AA08075FCH01	p. 100	p. 112
750 W	80 mm sq.	IP67	No	No	Battery-backup method absolute encoder	Round	No	R2AA08075FXP00	p. 100	p. 112
				No	Battery-backup method absolute encoder	With key	No	R2AA08075FXP11	p. 100	p. 112
				No	Absolute encoder for incremental system	Round	No	R2AA08075FXH00	p. 100	p. 112
				No	Absolute encoder for incremental system	With key	No	R2AA08075FXH11	p. 100	p. 112
				Yes	Battery-backup method absolute encoder	Round	No	R2AA08075FXP00M	p. 100	p. 112
				Yes	Absolute encoder for incremental system	Round	No	R2AA08075FXH00M	p. 100	p. 112
				Yes	Absolute encoder for incremental system	With key	No	R2AA08075FXH11M	p. 100	p. 112
			Yes (24 VDC)	No	Battery-backup method absolute encoder	Round	No	R2AA08075FCP00	p. 100	p. 112
				No	Battery-backup method absolute encoder	With key	No	R2AA08075FCP11	p. 100	p. 112
				No	Absolute encoder for incremental system	Round	No	R2AA08075FCH00	p. 100	p. 112
				No	Absolute encoder for incremental system	With key	No	R2AA08075FCH11	p. 100	p. 112
				Yes	Battery-backup method absolute encoder	Round	No	R2AA08075FCP00M	p. 100	p. 112
				Yes	Absolute encoder for incremental system	Round	No	R2AA08075FCH00M	p. 100	p. 112
				Yes	Absolute encoder for incremental system	With key	No	R2AA08075FCH11M	p. 100	p. 112
				Yes	Absolute encoder for incremental system	With key	No	R2AA08075FCH11M	p. 100	p. 112
1.0 kW	86 mm sq.	IP67	No	No	Battery-backup method absolute encoder	Round	No	R2AAB8100FXP04	p. 102	p. 112
				No	Battery-backup method absolute encoder	Round	No	R2AAB8100HXP04	p. 100	p. 112
				No	Absolute encoder for incremental system	Round	No	R2AAB8100FXH04	p. 102	p. 112
				No	Absolute encoder for incremental system	With key	Yes	R2AAB8100HXH5A	p. 100	p. 112
			Yes (24 VDC)	No	Battery-backup method absolute encoder	Round	No	R2AAB8100HCP04	p. 100	p. 112
				No	Absolute encoder for incremental system	With key	Yes	R2AAB8100HCH5A	p. 100	p. 112

Standard Model Number List

Standard Model Number List

For specifications on other models, contact us for details.

Input voltage **200 VAC** Made in The Philippines

R2 Servo Motor 200 V System, Medium Capacity, Medium Inertia

Rated output	Motor flange size	Protection code	Holding brake	CE and UL approved	Encoder	Output shaft	Oil seal	Model no.	Page					
									Specifications	Dimensions				
1.2 kW	130 mm sq.	IP65	No	No	Battery-backup method absolute encoder	With key	Yes	R2AA13120BXP00	p. 101	p. 113				
				No	Battery-backup method absolute encoder	With key	Yes	R2AA13120LXP00	p. 102	p. 113				
				No	Battery-backup method absolute encoder	With key	Yes	R2AA13120DXP00	p. 103	p. 113				
				No	Absolute encoder for incremental system	With key	Yes	R2AA13120BXH00	p. 101	p. 113				
				No	Absolute encoder for incremental system	With key	Yes	R2AA13120LXH00	p. 102	p. 113				
				No	Absolute encoder for incremental system	With key	Yes	R2AA13120DXH00	p. 103	p. 113				
			Yes (24 VDC)	No	Battery-backup method absolute encoder	With key	Yes	R2AA13120BCP00	p. 101	p. 113				
				No	Battery-backup method absolute encoder	With key	Yes	R2AA13120LCP00	p. 102	p. 113				
				No	Battery-backup method absolute encoder	With key	Yes	R2AA13120DCP00	p. 103	p. 113				
				No	Absolute encoder for incremental system	With key	Yes	R2AA13120BCH00	p. 101	p. 113				
				No	Absolute encoder for incremental system	With key	Yes	R2AA13120LCH00	p. 102	p. 113				
				No	Absolute encoder for incremental system	With key	Yes	R2AA13120DCH00	p. 103	p. 113				
				2.0 kW	130 mm sq.	IP65	No	No	Battery-backup method absolute encoder	With key	Yes	R2AA13200LXPW0	p. 103	p. 114
								No	Battery-backup method absolute encoder	With key	Yes	R2AA13200DXPW0	p. 103	p. 114
No	Absolute encoder for incremental system	With key	Yes					R2AA13200LXHW0	p. 103	p. 114				
No	Absolute encoder for incremental system	With key	Yes					R2AA13200DXHW0	p. 103	p. 114				
Yes (24 VDC)	No	Battery-backup method absolute encoder	With key				Yes	R2AA13200LCPW0	p. 103	p. 114				
	No	Battery-backup method absolute encoder	With key				Yes	R2AA13200DCPW0	p. 103	p. 114				
	No	Absolute encoder for incremental system	With key				Yes	R2AA13200LCHW0	p. 103	p. 114				
	No	Absolute encoder for incremental system	With key				Yes	R2AA13200DCHW0	p. 103	p. 114				

Set Models

Input voltage **200 VAC**

• We offer 30 to 750 W AC servo motors and servo amplifiers in sets with peripheral cables and connectors.

Set contents



Cable (option)

- **Extension cable for servo motor (1, 2, 3, 5, and 10 m)**
* Select the cable length
- **Encoder extension cable with battery**
* Not necessary when used as an incremental system
- **USB communication cable (1 and 2 m)**
* Select the cable length

Standard Model
Number List

Servo motor specifications Protection code: IP67, CE/UL approval: No, Encoder classification: Battery-backup method absolute encoder (Model no. PA035C), Output shaft: Straight, Oil seal: No, Connection: Cable with relay connector. (Connector specification → p.138)

Servo amplifier specifications Main circuit power supply: 3-Phase 200 to 240 VAC, Interface: Analog/Pulse input type, General output: Sink (NPN), Built-in regenerative resistor, Safe Torque Off function: No.

Rated output	Motor flange size	Holding brake	Order number for set models	Set components								
				Motor model no.	Page		Amplifier model no.	Page		Connector		
					Specifications	Dimensions		Specifications	Dimensions			
30 W	40 mm sq.	No	SR403X01	R2AA04003FXPA0	p. 98	p.112	RS3A01A0AA0	p. 44	p. 45	Connector for connections with host devices (CN1)		
		Yes (24 VDC)	SR403C01	R2AA04003FCPA0	p. 98	p.112						
50 W		No	SR405X01	R2AA04005FXPA0	p. 98	p.112						
		Yes (24 VDC)	SR405C01	R2AA04005FCPA0	p. 98	p.112						
90 W		Yes (24 VDC)	SR410C01	R2AA04010FCPA0	p. 98	p.112						
100 W		No	SR410X01	R2AA04010FXPA0	p. 98	p.112						
100 W		60 mm sq.	No	SR610X01	R2AA06010FXPA0	p. 98	p.112	RS3A02A0AA0	p. 44		p. 45	Connector for input power supply and regenerative resistor connections (CNA)
			Yes (24 VDC)	SR610C01	R2AA06010FCPA0	p. 98	p.112					
200 W	No		SR620X02	R2AA06020FXPA0	p. 99	p.112						
	Yes (24 VDC)		SR620C02	R2AA06020FCPA0	p. 99	p.112						
360 W	Yes (24 VDC)		SR640C02	R2AA06040FCPA0	p. 99	p.112						
400 W	No		SR640X02	R2AA06040FXPA0	p. 99	p.112						
750 W	80 mm sq.		No	SR875X03	R2AA08075FXPA0	p. 100	p.112	RS3A03A0AA0	p. 44	p. 45		
			Yes (24 VDC)	SR875C03	R2AA08075FCPA0	p. 100	p.112					

Set Models

Input voltage **200 VAC**

Options (sold separately) These items will be shipped altogether with the purchased set model.

Type	Cable length (m)	Model no.	Page	
Servo motor extension cable (Servo motor ↔ Servo amplifier)	(1) For power	1	RS-CM4-01-R	p. 138
		2	RS-CM4-02-R	p. 138
		3	RS-CM4-03-R	p. 138
		5	RS-CM4-05-R	p. 138
		10	RS-CM4-10-R	p. 138
	(2) For encoder	1	RS-CA4-01-R	p. 138
		2	RS-CA4-02-R	p. 138
		3	RS-CA4-03-R	p. 138
		5	RS-CA4-05-R	p. 138
		10	RS-CA4-10-R	p. 138
	(3) For brake	1	RS-CB3-01-R	p. 138
		2	RS-CB3-02-R	p. 138
		3	RS-CB3-03-R	p. 138
		5	RS-CB3-05-R	p. 138
		10	RS-CB3-10-R	p. 138
(4) Encoder extension cable with battery (Servo amplifier ↔ Encoder) Connected when using a battery-backup method absolute encoder	0.3	AL-00731792-01	p. 132	
(5) USB communication cable (PC communication cable for setup software)	1	AL-00896515-01	p. 131	
	2	AL-00896515-02	p. 131	

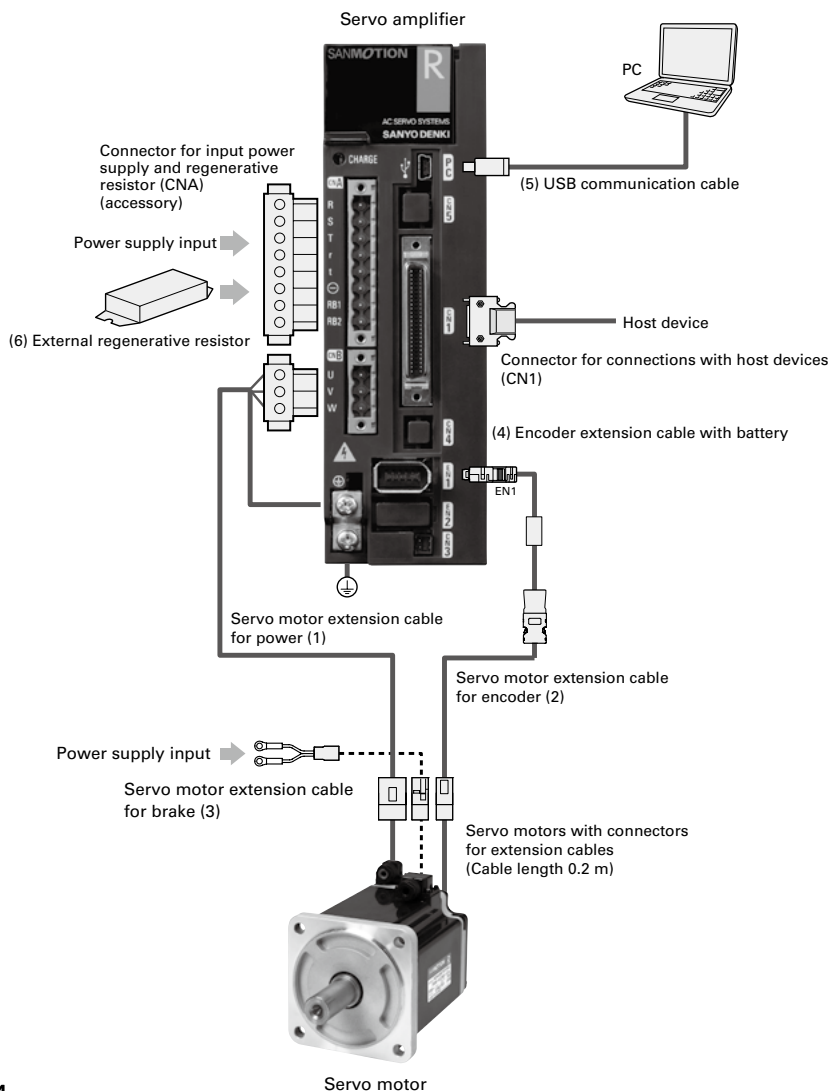

Servo Amplifiers

R 3E Model Analog/Pulse Input type

Servo Amplifier Capacity: 10 to 600 A

More evolved AC servo amplifiers that provide improved basic performance such as high responsiveness, and are more eco-efficient and easier to use.



How to read model numbers

Note that not all the possible combinations of the numbers and characters below are valid. Also, some of the numbers/characters listed below are for optional models. For model numbers valid as standard products, refer to "Standard Model Number List".

Servo amplifier

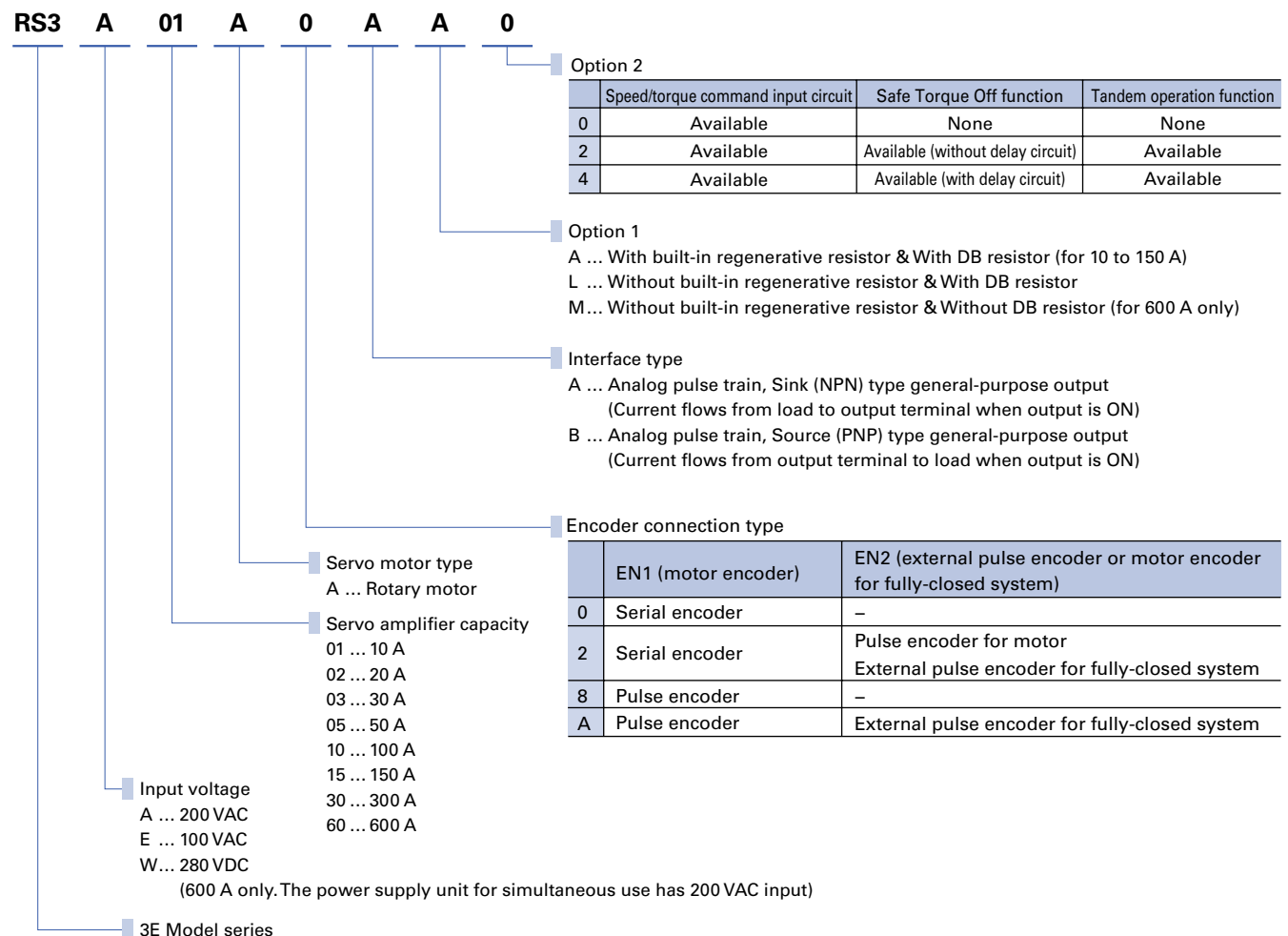

· Motor parameters need to be set for the amplifier before use. Please use the setup software for parameter setting.

Power supply unit for 600 A

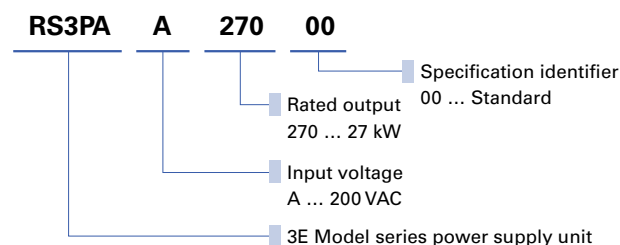

Options and Peripherals (10 to 50 A)

No.	Name	Model no.	Description	Page
1	Setup software	Can be downloaded from Product Information on our website.	Parameters can be set and monitored via communication with a PC.	p. 120
2	USB communication cable	AL-00896515-0□	PC communication cable for setup software	p. 131
3	Communication cable between amplifiers for tandem operation	AL-00911582-0□	Connects between amplifiers for tandem operation (CN5 ⇔ CN5)	p. 131
4	CN1 connector	AL-00385594	To connect to host device	p. 122
5	CN4 connector	AL-00718251-01 (for short circuits), AL-00718252-01 (for wiring)	To be connect to safety device (for short circuits and wiring)	p. 122
6	EN1, EN2 connectors	AL-00632607	To connect to encoders	p. 122
7	CN3 connector	—	To connect to battery box. Supplied with the battery box	—
8	CNA connector	AL-00686902-01	For input power supply and regenerative resistor connections	p. 122
9	CNB connector	AL-Y0004079-01	To connect to servo motor	p. 122
10	Battery box	AL-00880402-01	Used when using a battery-backup method absolute encoder	p. 132
11	Encoder extension cable with battery (with connectors on both ends)	AL-00731792-01	Used when using a battery-backup method absolute encoder (For servo motors with connector-less cable, use AL-00697960-□□ with a connector on one end.)	p. 132
12	Servo motor extension cable (Compatible with the optional servo motors with connectors for extension cables)	RS-CA4-□□-R	Encoder extension cable with connectors on both ends	p. 138
13		RS-CM4-□□-R	Power extension cable with connectors on both ends	p. 138
14		RS-CB3-□□-R	Brake extension cable with connectors on both ends	p. 138
15	External regenerative resistor	REGIST-□□□W□…□B REGIST-500CW□…□B	Used for special operations, such as high frequency applications that require greater power dissipation than that provided by the servo amplifier's built-in regenerative resistor	p. 133
16	Safety unit, safety PLC, etc.	To be provided by the customer	Connects I/O signals from the Safe Torque Off function to devices such as the safety unit and safety PLC.	—
17	Molded case circuit breaker (MCCB)	To be provided by the customer	Used to protect the power line.	—
18	Noise filter	To be provided by the customer	Used to prevent external noise from the power source line.	—
19	Electromagnetic contactor	To be provided by the customer	Used to switch the power on and off.	—
20	Brake power	To be provided by the customer	Used for servo motors with brake	—

Connector sets are also available with set model numbers. See respective pages.

System Configuration

100 to 150 A The photograph shows the 150 A model.

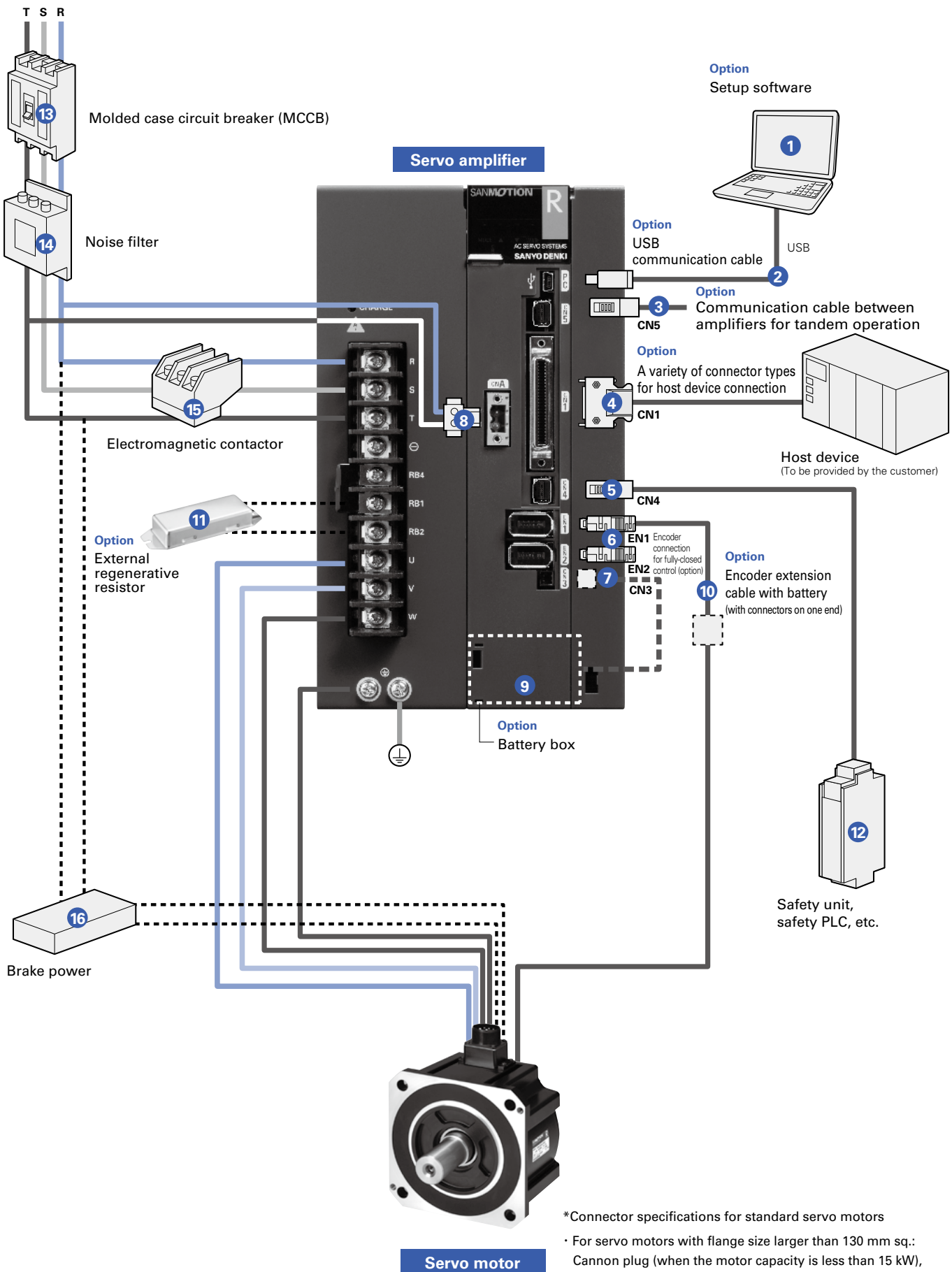

*Connector specifications for standard servo motors
 · For servo motors with flange size larger than 130 mm sq.:
 Cannon plug (when the motor capacity is less than 15 kW),
 Terminal block (when the motor capacity is more than 20 kW)

Options and Peripherals (100 to 150 A)

No.	Name	Model no.	Description	Page
1	Setup software	Can be downloaded from Product Information on our website.	Parameters can be set and monitored via communication with a PC.	p. 120
2	USB communication cable	AL-00896515-0□	PC communication cable for setup software	p. 131
3	Communication cable between amplifiers for tandem operation	AL-00911582-0□	Connects between amplifiers for tandem operation (CN5 ⇔ CN5)	p. 131
4	CN1 connector	AL-00385594	To connect to host device	p. 123
5	CN4 connector	AL-00718251-01 (for short circuits), AL-00718252-01 (for wiring)	To be connect to safety device (for short circuits and wiring)	p. 123
6	EN1, EN2 connectors	AL-00632607	To connect to encoders	p. 123
7	CN3 connector	—	To connect to battery box. Supplied with the battery box.	—
8	CNA connector	AL-Y0005159-01	For control circuit power supply input	p. 123
9	Battery box	AL-00880402-01	Used when using a battery-backup method absolute encoder	p. 132
10	Encoder extension cable with battery (with connectors on one end)	AL-00697960-□□	Used when using a battery-backup method absolute encoder	p. 132
11	External regenerative resistor	REGIST-□…□W□…□B, REGIST-500CW□…□B	Used for special operations, such as high frequency applications that require greater power dissipation than that provided by the servo amplifier's built-in regenerative resistor	p. 133
12	Safety unit, safety PLC, etc.	To be provided by the customer	Connects I/O signals from the Safe Torque Off function to devices such as the safety unit and safety PLC.	—
13	Molded case circuit breaker (MCCB)	To be provided by the customer	Used to protect the power line.	—
14	Noise filter	To be provided by the customer	Used to prevent external noise from the power source line.	—
15	Electromagnetic contactor	To be provided by the customer	Used to switch the power on and off.	—
16	Brake power	To be provided by the customer	Used for servo motors with brake	—

Connector sets are also available with set model numbers. See respective pages.

System Configuration

300 A

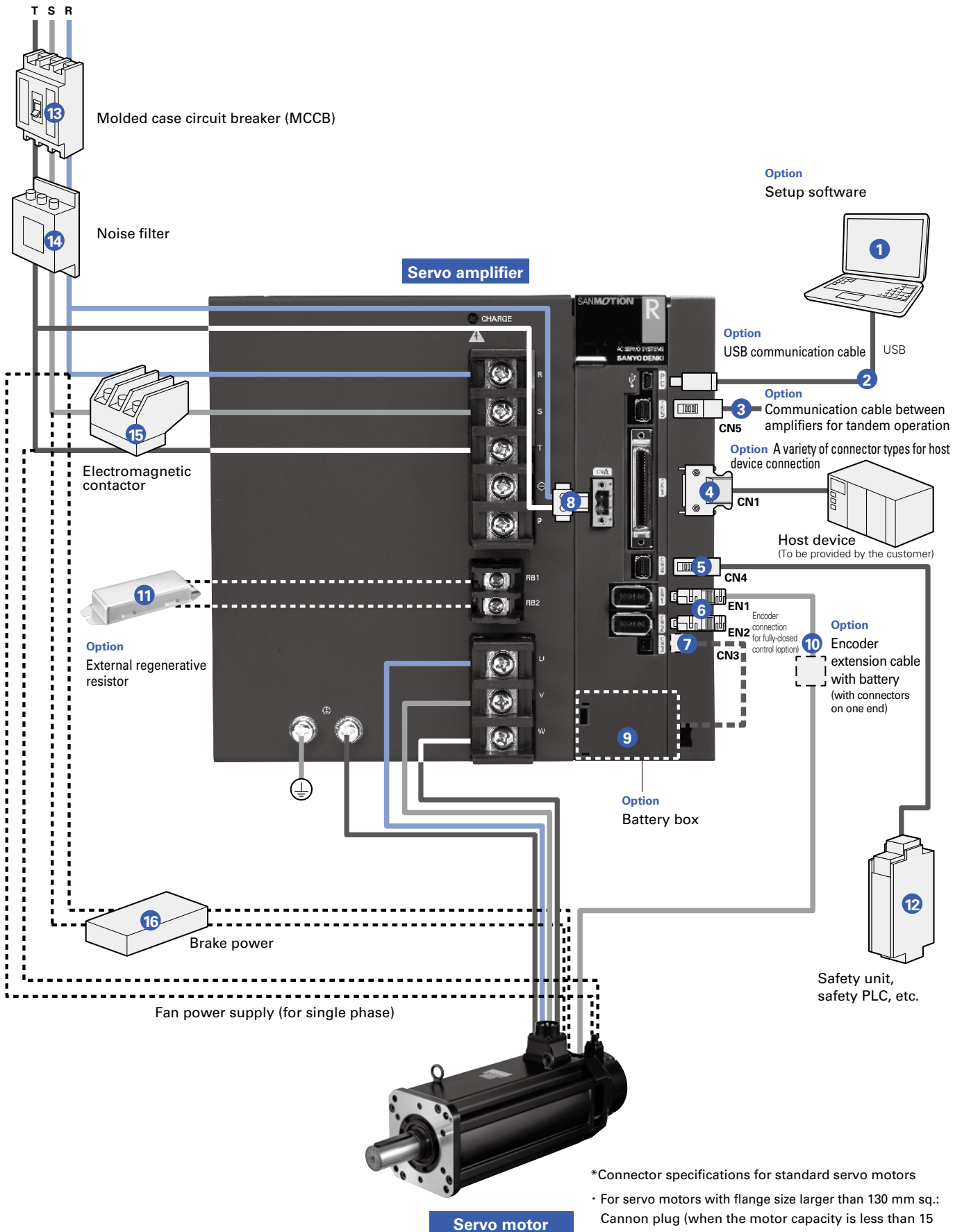

*Connector specifications for standard servo motors
 • For servo motors with flange size larger than 130 mm sq.:
 Cannon plug (when the motor capacity is less than 15 kW), Terminal block (when the motor capacity is more than 20 kW)

Options and Peripherals (300 A)

No.	Name	Model no.	Description	Page
1	Setup software	Can be downloaded from Product Information on our website.	Parameters can be set and monitored via communication with a PC.	p. 120
2	USB communication cable	AL-00896515-0□	PC communication cable for setup software	p. 131
3	Communication cable between amplifiers for tandem operation	AL-00911582-0□	Connects between amplifiers for tandem operation (CN5 ⇔ CN5)	p. 131
4	CN1 connector	AL-00385594	To connect to host device	p. 123
5	CN4 connector	AL-00718251-01 (for short circuits), AL-00718252-01 (for wiring)	To be connect to safety device (for short circuits and wiring)	p. 123
6	EN1, EN2 connectors	AL-00632607	To connect to encoders	p. 123
7	CN3 connector	—	To connect to battery box. The connector is supplied with the battery box.	—
8	CNA connector	AL-Y0005159-01	For control circuit power supply input	p. 123
9	Battery box	AL-00880402-01	Used when using a battery-backup method absolute encoder	p. 132
10	Encoder extension cable with battery (with connectors on one end)	AL-00697960-□□	Connected when using a battery-backup method absolute encoder with an extension cable	p. 132
11	External regenerative resistor	REGIST-□…□W□…□B, REGIST-500CW□…□B	Used for special operations, such as high frequency applications that require greater power dissipation than that provided by the servo amplifier's built-in regenerative resistor	p. 133
12	Safety unit, safety PLC, etc.	To be provided by the customer	Connects I/O signals from the Safe Torque Off function to devices such as the safety unit and safety PLC.	—
13	Molded case circuit breaker (MCCB)	To be provided by the customer	Used to protect the power line.	—
14	Noise filter	To be provided by the customer	Used to prevent external noise from the power source line.	—
15	Electromagnetic contactor	To be provided by the customer	Used to switch the power on and off.	—
16	Brake power	To be provided by the customer	Used for servo motors with brake	—

Connector sets are also available with set model numbers. See respective pages.

System Configuration

600 A

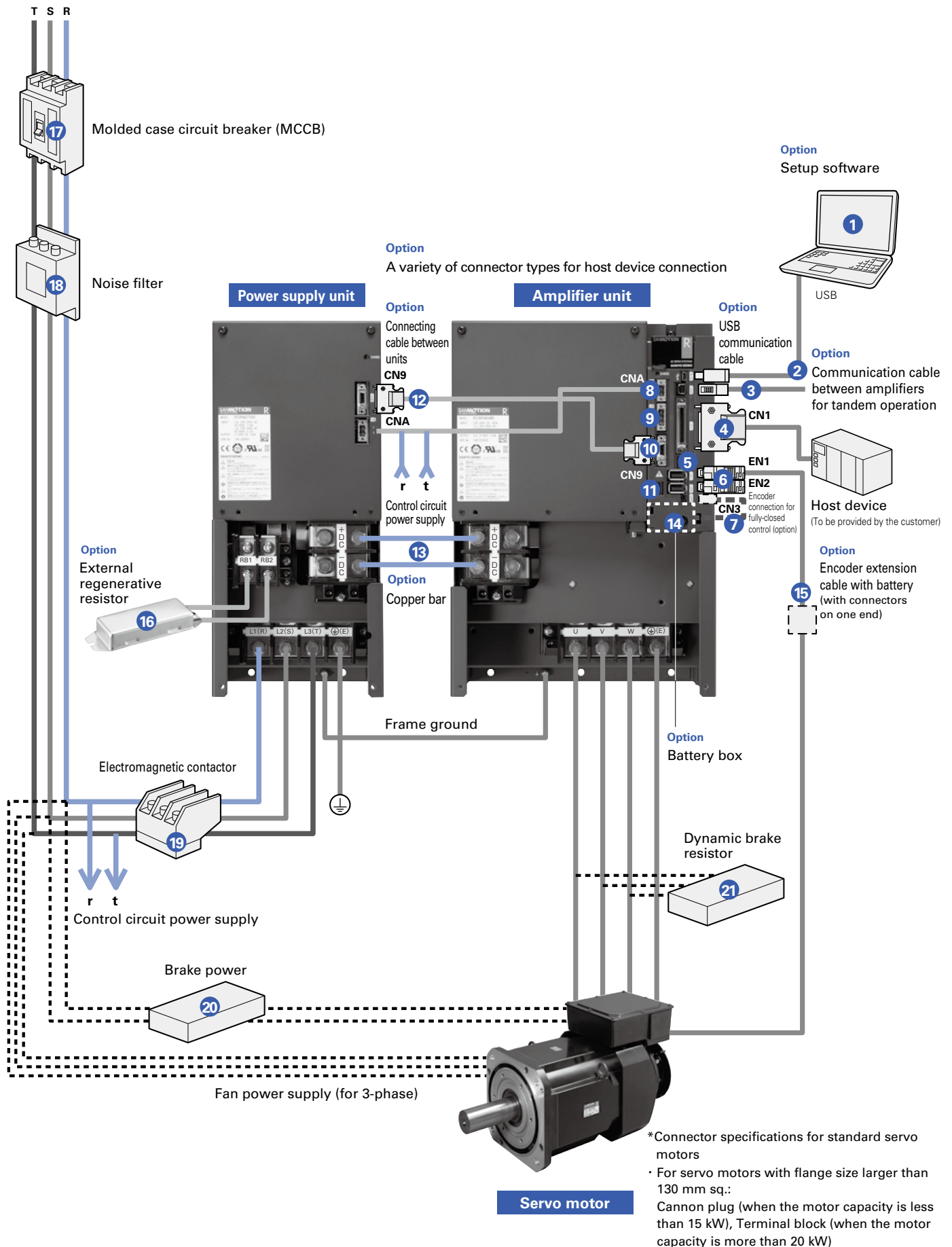

*Connector specifications for standard servo motors
 • For servo motors with flange size larger than 130 mm sq.:
 Cannon plug (when the motor capacity is less than 15 kW), Terminal block (when the motor capacity is more than 20 kW)

Options and Peripherals (600 A)

No.	Name	Model no.	Description	Page
1	Setup software	Can be downloaded from Product Information on our website.	Parameters can be set and monitored via communication with a PC.	p. 120
2	USB communication cable	AL-00896515-0□	PC communication cable for setup software	p. 131
3	Communication cable between amplifiers for tandem operation	AL-00911582-0□	Connects between amplifiers for tandem operation (CN5 ⇔ CN5)	p. 131
4	CN1 connector	AL-00385594	To connect to host device	p. 124
5	CN4 connector	AL-00718251-01 (for short circuits), AL-00718252-01 (for wiring)	To be connect to safety device (for short circuits and wiring)	p. 124
6	EN1, EN2 connectors	AL-00632607	To connect to encoders	p. 124
7	CN3 connector	—	To connect to battery box. Supplied with the battery box.	—
8	CNA connector	AL-Y0005159-01	For control circuit power supply input	p. 124
9	CNB connector	AL-Y0004079-01	For dynamic brake signal	p. 124
10	CN9 connector	AL-00608710	To connect between units (single item)	p. 124
11	CN8 connector	AL-Y0011185-01	For external alarm signal	p. 124
12	Connection cable between units	AL-00917284	To connect between power unit (CN9) and amplifier unit (CN9)	p. 124
13	Copper bar	AL-00918125-01	To connect main power supply between power unit (CN9) and amplifier unit (CN9) Terminal number: Between +DC/-DC 2-pc. set (5 mm between units)	p. 124
14	Battery box	AL-00880402-01	Connected when using a battery-backup method absolute encoder	p. 132
15	Encoder extension cable with battery (with connectors on one end)	AL-00697960-□□	Connected when using a battery-backup method absolute encoder	p. 132
16	External regenerative resistor	REGIST-□□□□W□□□B, REGIST-500CW□□□□B	Used for special operations, such as high frequency applications that require greater power dissipation than that provided by the servo amplifier's built-in regenerative resistor	p. 133
17	Molded case circuit breaker (MCCB)	To be provided by the customer	Used to protect the power line.	—
18	Noise filter	To be provided by the customer	Used to prevent external noise from the power source line.	—
19	Electromagnetic contactor	To be provided by the customer	Used to switch the power on and off.	—
20	Brake power	To be provided by the customer	Used for servo motors with brake	—
21	Dynamic brake resistor	To be provided by the customer	Not built in this servo amplifier. Connect as necessary.	—

Connector sets are also available with set model numbers. See respective pages.

General Specifications

Control function	Position control/Speed control/Torque control (Parameter switching)	
Control system	IGBT: PWM control, sinusoidal drive	
Main Circuit Power Supply *1	3-Phase: 200 to 240 VAC +10, -15%, 50/60 Hz±3 Hz Single-phase: 200 to 240 VAC +10, -15%, 50/60 Hz±3 Hz *2 Single-phase: 100 to 120 VAC +10, -15%, 50/60 Hz±3 Hz *3	
Control circuit power supply *1	Single-phase: 200 to 240 VAC +10, -15%, 50/60 Hz±3 Hz Single-phase: 100 to 120 VAC +10, -15%, 50/60 Hz±3 Hz *3	
Environment	Ambient temperature	0 to +55°C
	Storage temperature	-20 to +65°C
	Operation and Storage humidity	Below 90%RH (non-condensing)
	Operation altitude	Below 1000 m
	Vibration resistance	4.9 m/s ² freq. range 10 to 55 Hz tested for 2 hours in each X, Y and Z-axis directions
	Impact resistance	19.6m/s ²
Structure	10 to 300 A: Built-in tray type power supply, 600 A: Separate power supply unit	

*1 Power source voltage should be within the specified range below.
[200 VAC power input type]:
Specified power supply range = 170 to 264 VAC
[100 VAC power input type]:
Specified power supply range = 85 to 132 VAC *2
The 200 VAC single-phase input type is compatible only with RS3□01, RS3□02, RS3□03, and RS3□05.
Please set parameters before using single-phase input.
*3
The 100 VAC single-phase input type is compatible only with RS3□01, RS3□02, and RS3□03.
Please set parameters before using single-phase input.



Performance

Speed control range	1:5000 (Internal speed command)
Frequency characteristics	2200 Hz (In high frequency sampling mode) *Differs for each model.
Permissible load moment of inertia	10 times the motor rotary inertia

Built-in functions

Protection functions	Overcurrent, Current detection error, Overload, Regeneration error, Overheating, External error, Overvoltage, Main circuit power supply undervoltage Main circuit power supply open phase, Control circuit power supply undervoltage, Encoder error, Overspeed, Speed control error, Speed feedback error, Excessive position deviation, Position command pulse error, Built-in memory error, Parameter error, Cooling fan error
Digital operator	Status display, Monitor display, Alarm display, Parameter setting, Test run, Adjustment mode
Dynamic brake circuit	Built in/None selectable (except for 600 A)
Regenerative resistor	10 to 150 A: Models with or without built-in resistor selectable, 300 to 600 A: None *For all models from 10 to 600 A, optional external resistors can be equipped.
Monitor	Speed monitor (VMON) 2.0 V±10% (at 1000 min ⁻¹), Torque (thrust force) command monitor (TCMON) 2.0 V±10% (at 100%)

Safety standards

Servo amplifier type	Safety standards		
All models	North American safety standards (UL ratings)	UL508C	
	North American safety standards (UL ratings)	Low-voltage directive	EN61800-5-1
		EMC directive	EN55011 G1 ClassA, EN61800-3, EN61326-3-1
KC Mark (Korea Certification Mark)	KN61000-6-2, KN61000-6-4		
Models equipped with the SafeTorque Off function only	Safety feature standards	IEC 61508: SIL3, ISO 13849-1 Cat.3: PL=e, IEC 62061: SILCL3	

General-purpose output specifications

Sink type (NPN)

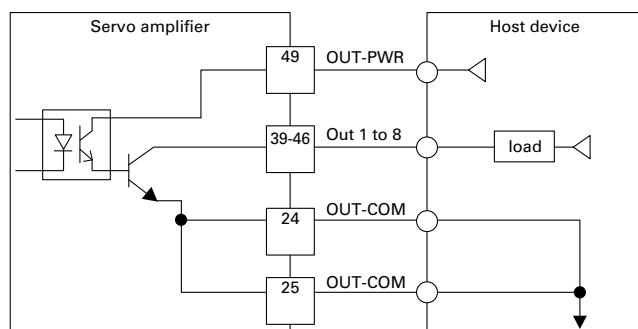

Source type (PNP)

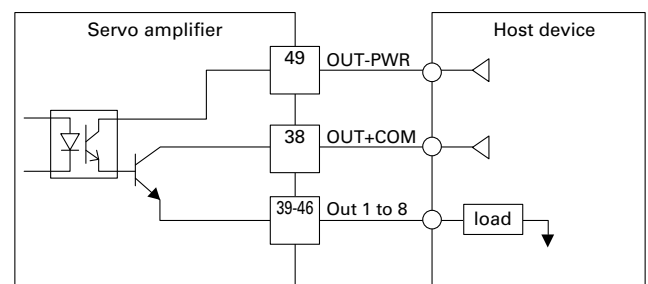

Dimensions [Unit : mm]

10 A

Mass: Without built-in regenerative resistor 0.68 kg
 With built-in regenerative resistor 0.73 kg

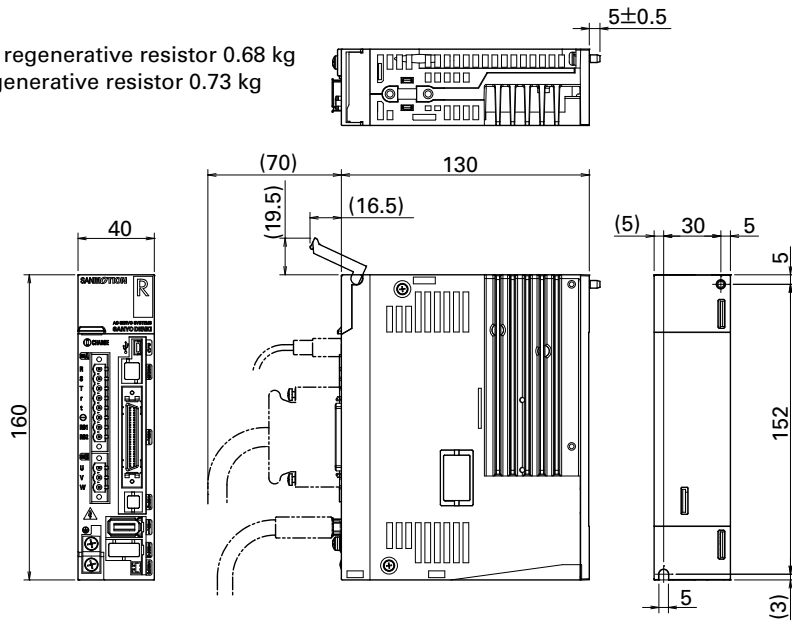

20 A

Mass: Without built-in regenerative resistor 0.70 kg
 With built-in regenerative resistor 0.75 kg

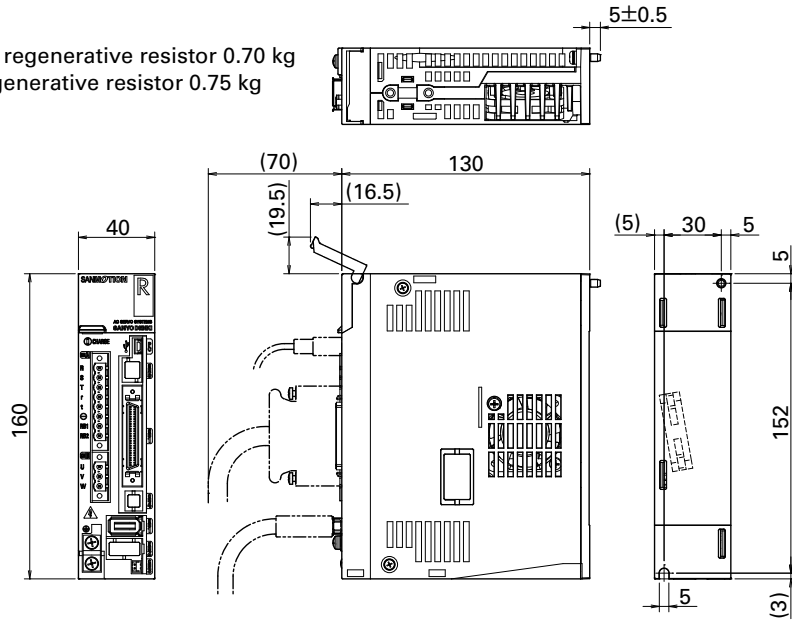

30 A

Mass: Without built-in regenerative resistor 0.8 kg
 With built-in regenerative resistor 0.85 kg

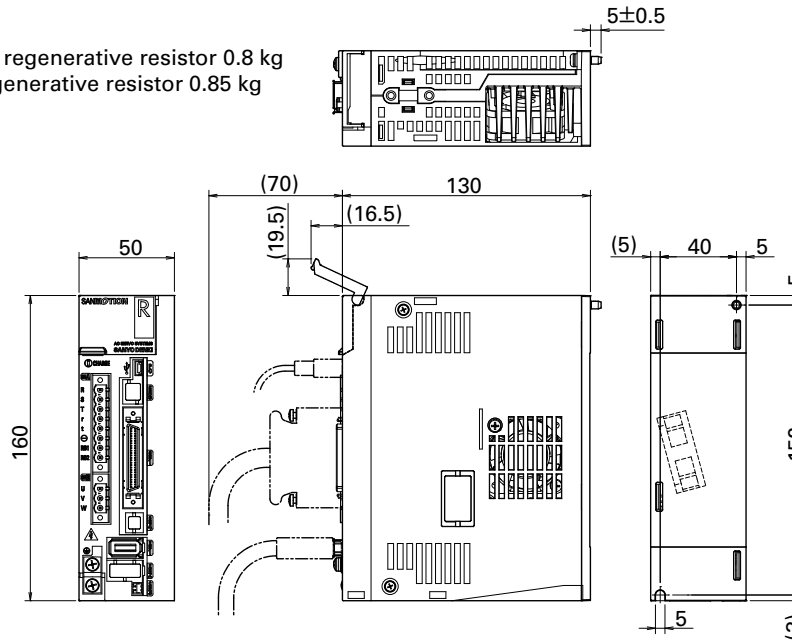

Dimensions [Unit: mm]

50 A

Mass: Without built-in regenerative resistor 1.5 kg
 With built-in regenerative resistor 1.55 kg

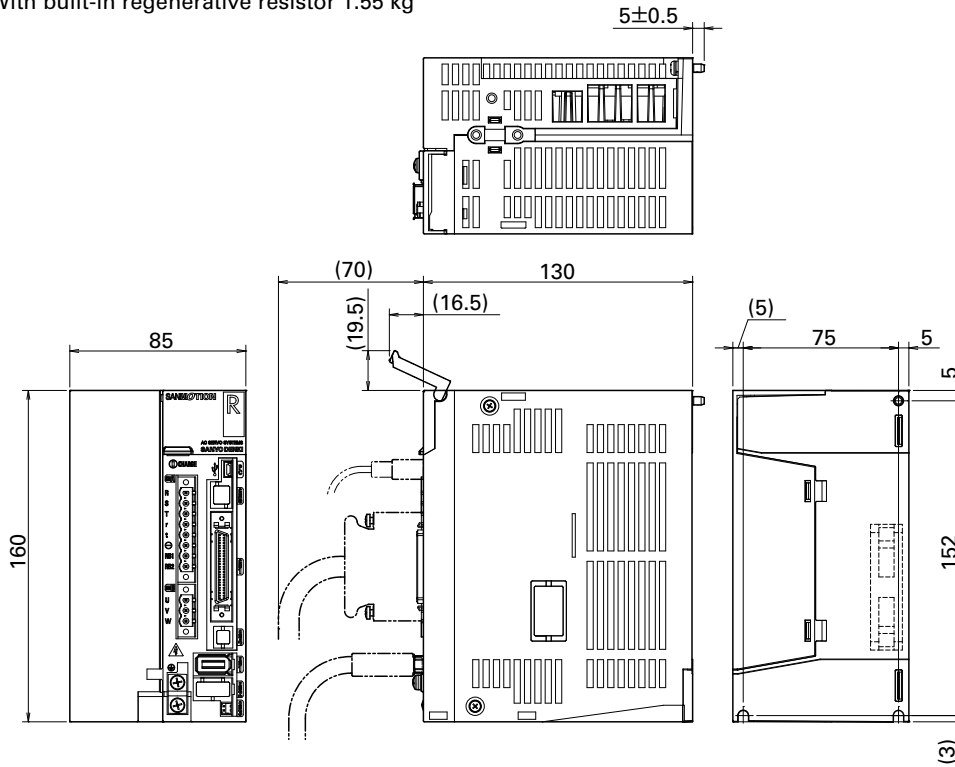

100 A

Mass: Without built-in regenerative resistor 4.0 kg
 With built-in regenerative resistor 4.2 kg

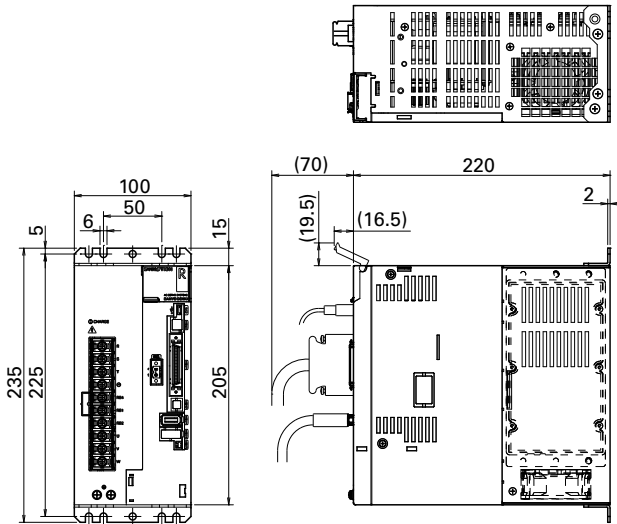

150 A

Mass: Without built-in regenerative resistor 4.7 kg
 With built-in regenerative resistor 4.9 kg

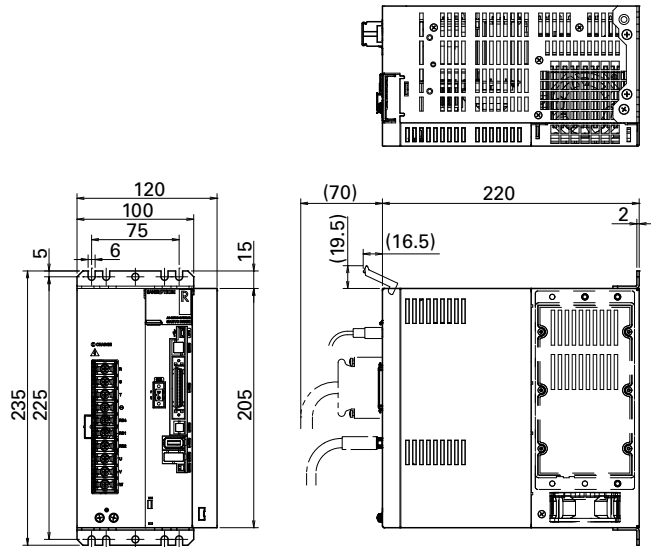

Dimensions [Unit: mm]

300 A

Mass: 9.8 kg

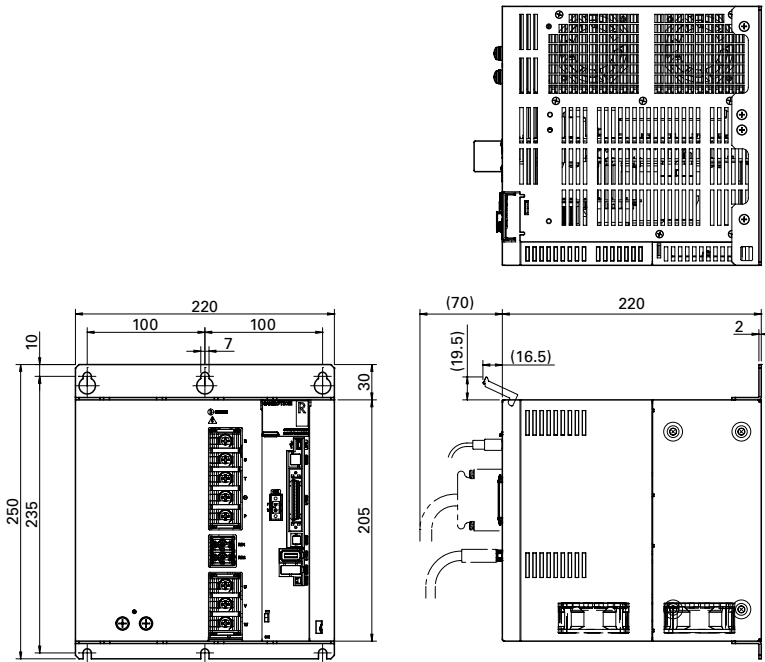

600 A

Power supply unit Mass: 11.8 kg

Amplifier unit Mass: 18 kg

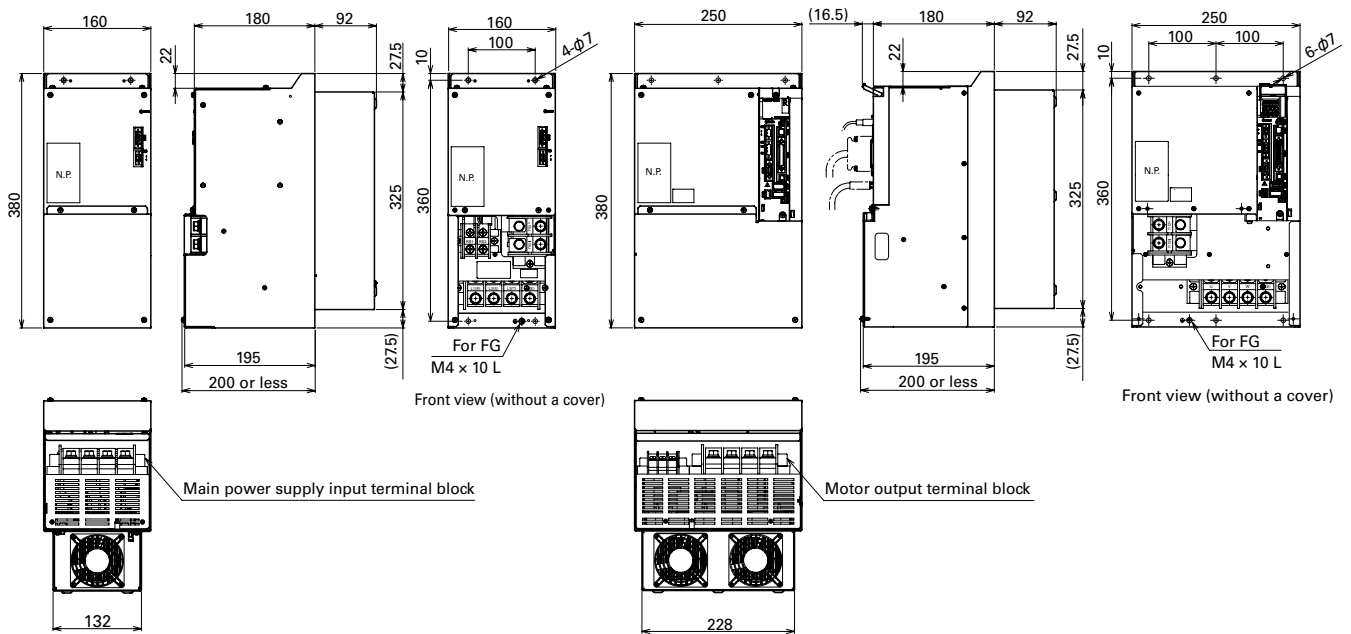

External Wiring Diagram

10 to 300 A, Sink type (NPN) output

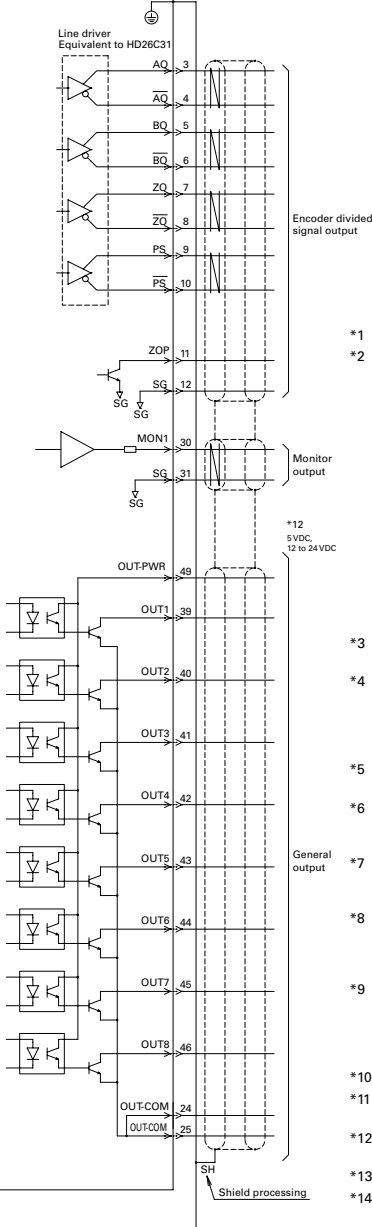
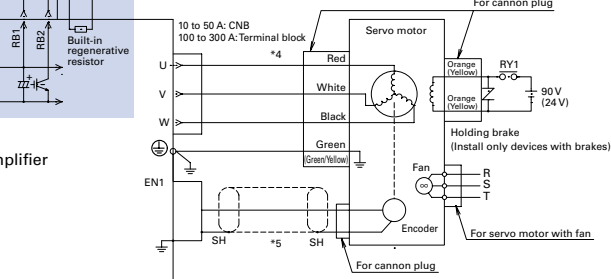
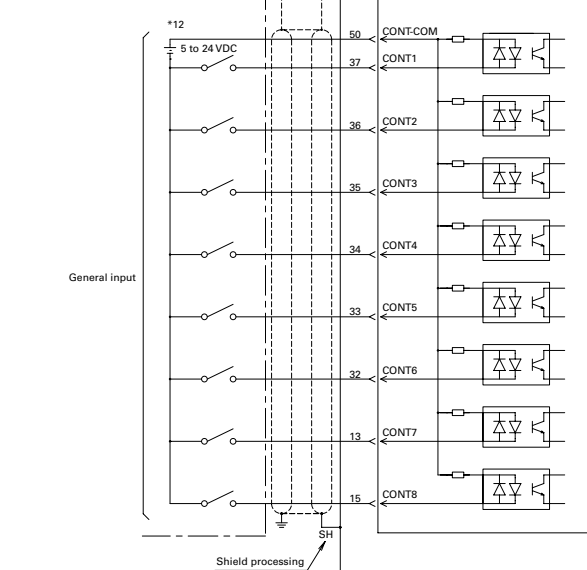
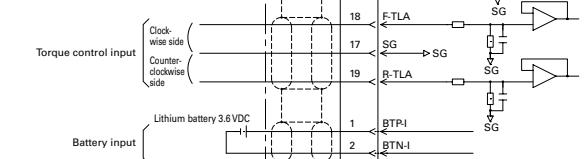
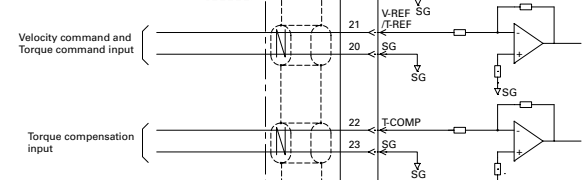
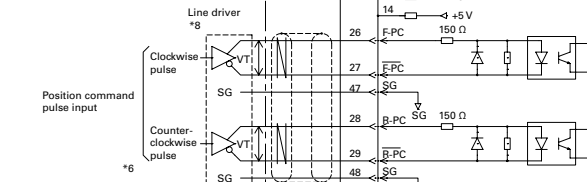
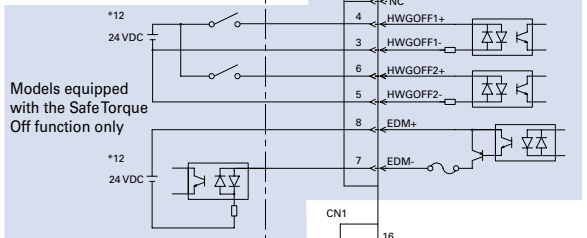
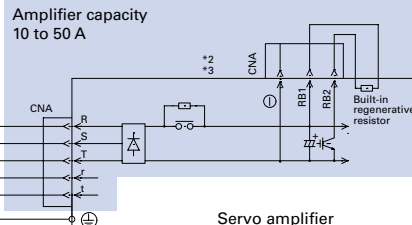
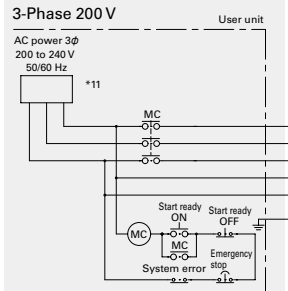
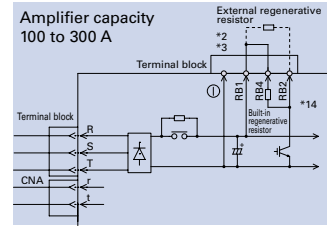
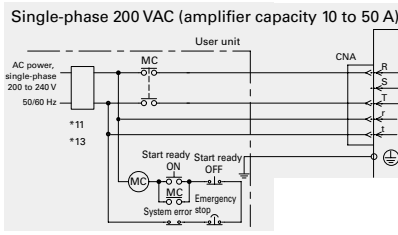
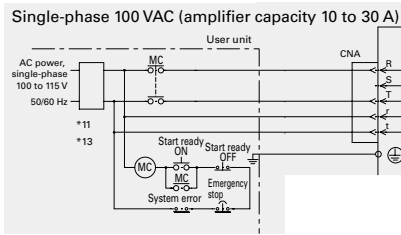

Connector No.	Name	Housing, Plug, Shell
CNA 10 to 50 A	Main power supply, Control circuit power supply input connector	MSTBT2.5/8-STF-5.08LUB
CNA 100 to 300 A	Control circuit power supply input connector	MSTBT2.5/2-STF-5.08
CNB 10 to 50 A	Servo motor power line connector	MSTBT2.5/3-STF-5.08
CN1	Connector for host device input signal	Plug: 10150-3000PE Shell: 10350-52A0-008
EN1	Connector for encoder signal	Connector: 36210-0100PL Shell kit: 36310-3200-008
CN4	Connector for Safe Torque Off function signal	For short circuits: 2040978-1 For wiring: 2013595-3

- *1 Use a twisted pair shielded cable.
- *2 For amplifier capacity 10 to 50 A:
Connect an external regenerative resistor between the RB1-RB2 terminals. When using an external regenerative resistor, remove the wiring of the built-in regenerative resistor connected between the RB1 and RB2 terminals and then connect the external regenerative resistor between the RB1 and RB2 terminals.
For amplifier capacity 100 to 150 A:
When using the built-in regenerative resistor, short the circuit between the RB1-RB4 terminals. When using an external regenerative resistor, remove the shorting bar connected between the RB1 and RB4 terminals and then connect the regenerative resistor between the RB1 and RB2 terminals.
- *3 \ominus is a maintenance terminal (high-voltage circuit). Do not wire this terminal.
- *4 Motor connection differs by the motor specifications. The indications of red, white, black, green and orange apply when the motor power and brake lines are the lead type. When they are the cannon plug type, connect them according to the motor specifications.
- *5 Refer to the encoder connection figure for the wiring of the connector for the encoder connection.
- *6 Be sure to connect SG (signal ground) between the equipment and the servo amplifier when you use a differential input signal.
- *7 R, S, T, r, t, \ominus , RB1, RB2, U, V, W are high-voltage circuits. All other lines are low-voltage. Ensure that there is sufficient differential between the high- and low-voltage circuits.
- *8 Use a line driver with a differential voltage difference (VT) from 2.5 V to 3.8 V. If the differential voltage is less than 2.5 V or more than 3.8 V, it may lead to malfunction due to missing pulses.
- *9 CN4 is a connector for safety function signals. To turn the servo motor power ON, a safety device must be connected and the wiring to activate the safety function must be done. When not using the safety function, use an optional connector (P/N: AL-00718251-01) inserted into the CN4.
- *10 Do not connect anything to CN4 pin 1 and 2.
- *11 An earth leakage circuit breaker conforming either to UL, IEC, or EN standards is recommended.
- *12 The external power supply is to be arranged by the customer.
- *13 Do not wire the S phase for a single-phase power supply.
- *14 There is no built-in regenerative resistor or RB4 terminal for 300 A capacity amplifiers.

External Wiring Diagram

600 A, Sink type (NPN) output

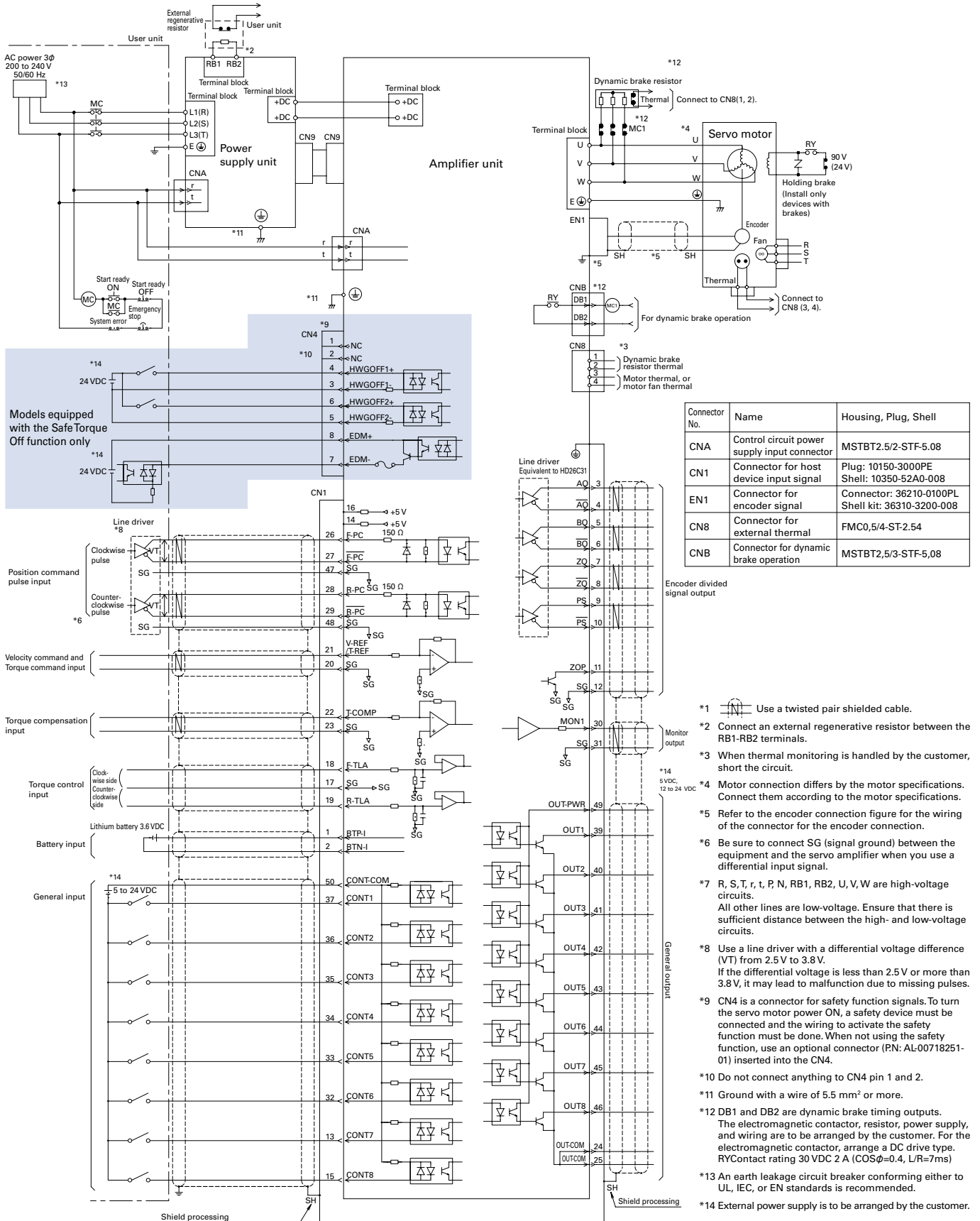

External Wiring Diagram

600A, Source type (PNP) output

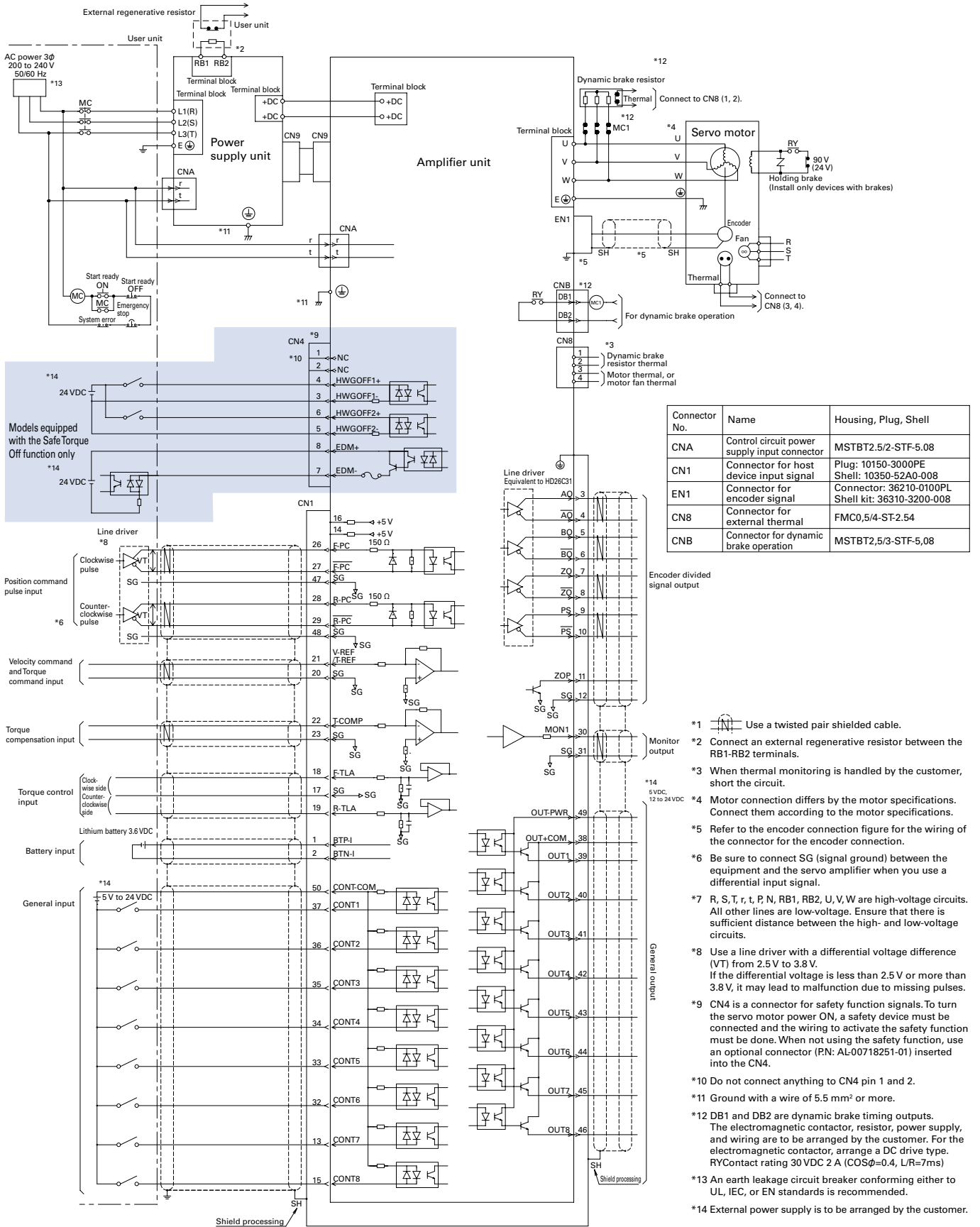

Notes on Replacing R ADVANCED MODEL

Note the following when replacing our conventional SANMOTION R ADVANCED MODEL amplifier with SANMOTION R 3E Model.

Position command pulse input

There are constraints on the specifications of the available position pulse signals for the SANMOTION R 3E Model. Also, if the host device output is open collector type, a wiring change is necessary.

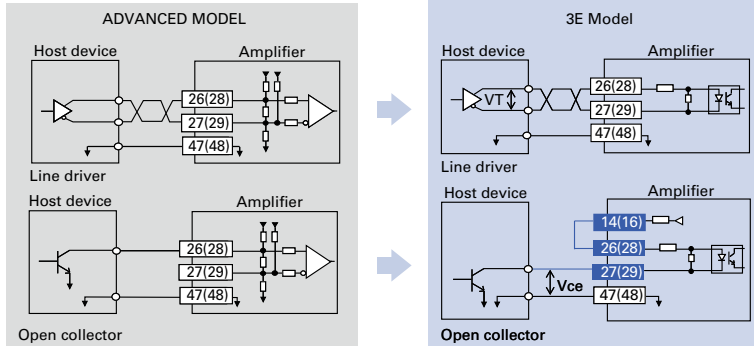

Pulse output circuit of the host devices	Wiring compatibility	Constraint conditions
Differential output type (Line driver)	Yes	Voltage difference between differential signals (VT) : 2.5 to 3.8V
Open collector type	No	Saturation voltage of the transistor (Vce): 1.5V max.

General input

For the SANMOTION R 3E Model, differential (line driver) output type cannot be used as a host device side output circuit. Furthermore, wiring change will be required even if open collector output is used.

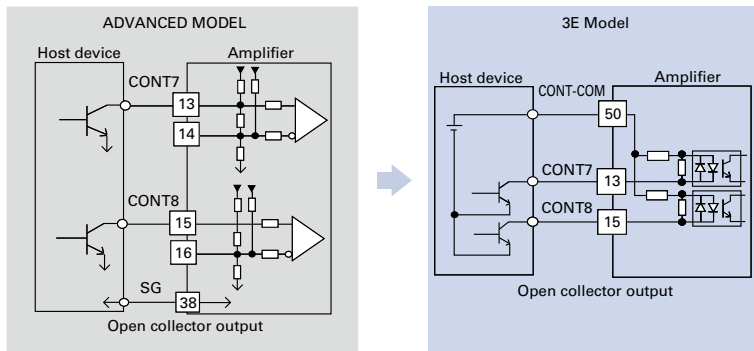

General output circuit of the host devices	Wiring compatibility	Constraint conditions
Differential output type (Line driver)	-	Change to open collector type.
Open collector type	No (Refer to the figure)	Wire in the same way as CONT1 to 6.

Encoder Wiring Diagram

Serial Encoder

Battery-less optical absolute encoder [Model No. HA035]

Optical absolute encoder for incremental systems [Model No. PA035S]

Option: Optical battery-backup method absolute encoder [Model No. PA035C]

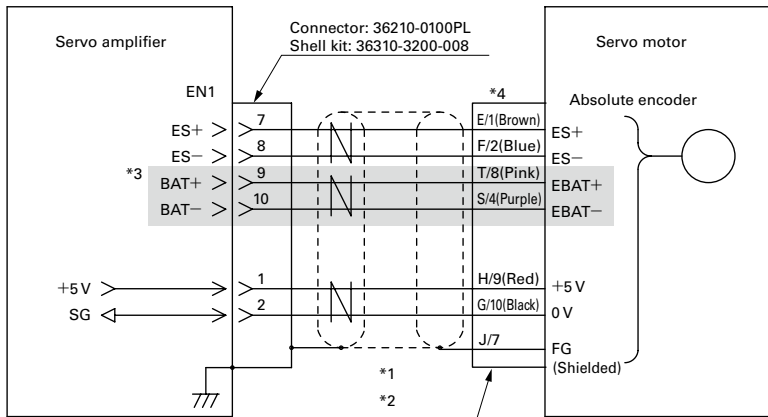

Cannon plug model no. _____

Flange size: 130 mm sq. or larger	JN2DS10SL1-R	JN2FS10SL1-R
	JN2DS10SL2-R	JN2FS10SL2-R
	JN2DS10SL3-R	JN2FS10SL3-R

- *1 Use a shielded twisted pair cable.
- *2 Maximum cable lengths by conductor size of the power supply cable (5V, SG) are shown in the table below.

Conductor size		Conductor resistance (Ω/km) *at 20°C	Length (m)
AWG	SQ (mm ²)		
26	0.15	150 or less	5
24	0.2	100 or less	10
22	0.3	60 or less	15
20	0.5	40 or less	25
18	0.75	25 or less	40

*Conductor resistance differs by conductor specifications.

- *3 Battery lines (EBAT+, EBAT-) are necessary only when a battery-backup method absolute encoder is used.
- *4 Lead wire colors are indicated in parentheses. For lead wire colors and cannon plug pin numbers, see the following table.

	ES+	ES-	EBAT+	EBAT-	+5V	0V	FG
100 mm sq. or smaller	Brown	Blue	Pink*3	Purple*3	Red	Black	Shielded
130 mm sq. or larger	1	2	8*3	4*3	9	10	7

Option: Pulse Encoder

Wire-saving incremental encoder

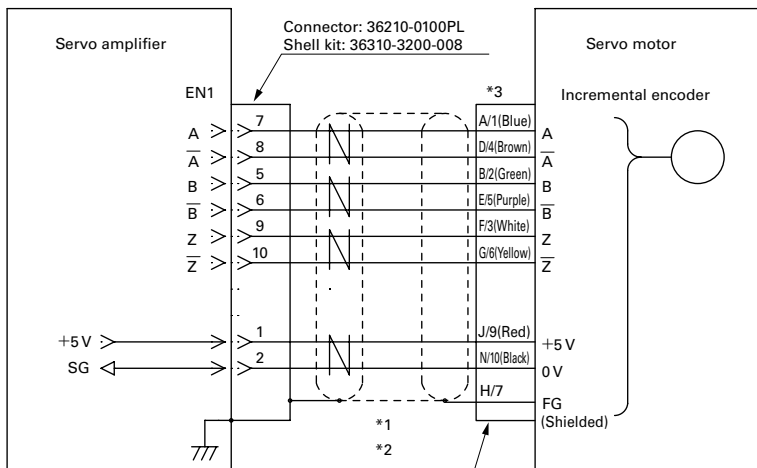

Cannon plug model no. _____

Flange size: 130 mm sq. or larger	JN2DS10SL1-R	JN2FS10SL1-R
	JN2DS10SL2-R	JN2FS10SL2-R
	JN2DS10SL3-R	JN2FS10SL3-R

- *1 Use a shielded twisted pair cable.
- *2 Maximum cable lengths by conductor size of the power supply cable (5V, SG) are shown in the table below.

Conductor size		Conductor resistance (Ω/km) *at 20°C	Length (m)
AWG	SQ (mm ²)		
26	0.15	150 or less	5
24	0.2	100 or less	10
22	0.3	60 or less	15
20	0.5	40 or less	25
18	0.75	25 or less	40

*Conductor resistance differs by conductor specifications.

- *3 Lead wire colors are indicated in parentheses. For lead wire colors and cannon plug pin numbers, see the following table:

	A	Ā	B	B̄	Z	Z̄	+5V
100 mm sq. or smaller	Blue	Brown	Green	Purple	White	Yellow	Red
130 mm sq. or larger	1	4	2	5	3	6	9
	0V	FG					
100 mm sq. or smaller	Black	Shielded					
130 mm sq. or larger	10	7					

Servo Amplifiers

R ADVANCED MODEL

EtherCAT Interface type Servo Amplifier Capacity: 15 to 300 A

The EtherCAT communication cycle is fast (0.125 ms) and position commands are subdivided, making device operations smoother.

A new product with faster communication cycle and improved controllability. It uses a different connector from our conventional EtherCAT interface type (Model no.: RS2□□□A□K)



How to read model numbers

Note that not all the possible combinations of the numbers and characters below are valid.

Also, some of the numbers/characters listed below are for optional models.

For model numbers valid as standard products, refer to "Standard Model Number List".

RS2 A 01 A 2 H A 5

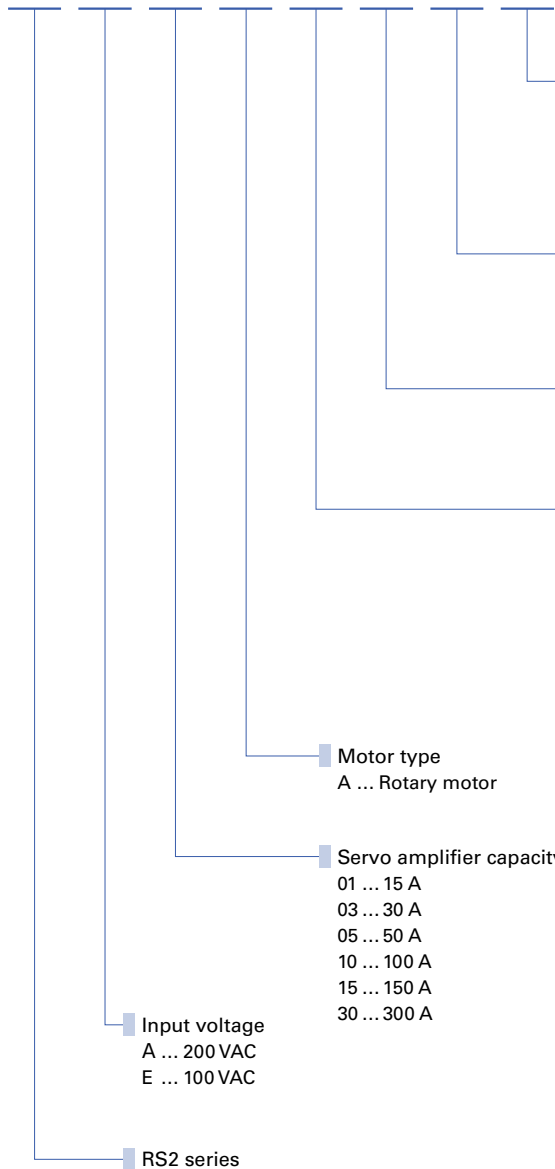

Option 2

	Safe torque Off function	General I/O
5	Equipped (with delay circuit)	Input x 6 Output x 2

Option 1

A ... With built-in regenerative resistor & With DB resistor (for 10 to 150 A)
L ... Without built-in regenerative resistor & With DB resistor

Interface type

H ... EtherCAT interface type (high-speed communication)

Encoder connection type (rotary motor)

	EN1 (motor encoder)	EN2 (external pulse encoder)
2	Serial encoder	Pulse encoder
A	Pulse encoder	Pulse encoder

* If servo amplifiers are to be used in fully-closed systems, for which both of the motor encoder and the external encoder are used, the amplifier model no. should have either "2" or "A" as its "encoder connection type" character, as in the above table.

* If a serial encoder is to be connected to EN1 and used in a semi-closed system, for which only one encoder is connected, the amplifier model no. should have "2" as its "encoder connection type" character.

Instead, a pulse encoder can also be used as a motor encoder when connected to EN2. It configures another semi-closed system with the "encoder connection type" character of 2.

- Motor parameters need to be set for the amplifier before use. Please use the setup software for parameter setting.

System Configuration

15 to 50 A The photograph shows the 15 A model.

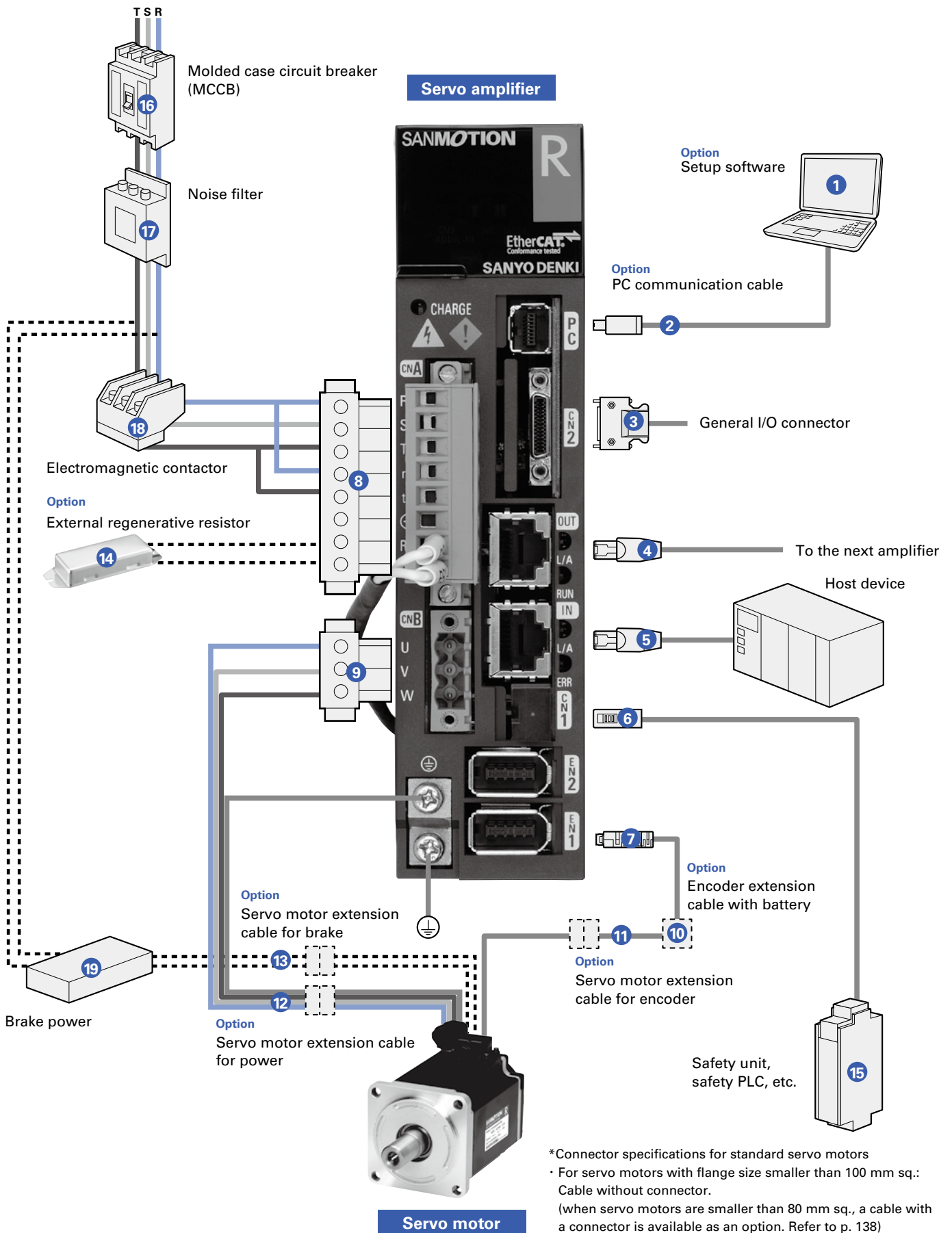

*Connector specifications for standard servo motors
 • For servo motors with flange size smaller than 100 mm sq.: Cable without connector.
 (when servo motors are smaller than 80 mm sq., a cable with a connector is available as an option. Refer to p. 138)
 • For servo motors with flange size larger than 130 mm sq.: Cannon plug (when the motor capacity is less than 15 kW), Terminal block (when the motor capacity is more than 20 kW)

Options and Peripherals (15 to 50A)

No.	Name	Model no.	Description	Page
1	Setup software	Can be downloaded from Product Information on our website.	Parameters can be set and monitored via communication with a PC.	p. 120
2	PC communication cable	AL-00689703-01	PC communication cable for setup software	p. 131
3	CN2 connector	AL-00842383	General I/O connector	p. 125
4	OUT connector	To be provided by the customer	EtherCAT OUT (to the next amplifier)	—
5	IN connector	To be provided by the customer	EtherCAT IN (host device)	—
6	CN1 connector	AL-00718252-01	To connect safety device	p. 125
7	EN1, EN2 connectors	AL-00632607	To connect to encoders	p. 125
8	CNA connector	AL-00686902-01	For input power supply and regenerative resistor connections	p. 125
9	CNB connector	AL-Y0004079-01	To connect to servo motor	p. 125
10	Encoder extension cable with battery	AL-00731792-01	Used when using a battery-backup method absolute encoder (For servo motors with connector-less cable, use AL-00697960-□□ with a connector on one end.)	p. 132
11	Servo motor extension cable (Compatible with the optional servo motors with connectors for extension cables)	RS-CA4-□□-R	Encoder extension cable with connectors on both ends	p. 138
12		RS-CM4-□□-R	Power extension cable with connectors on both ends	p. 138
13		RS-CB3-□□-R	Brake extension cable with connectors on both ends	p. 138
14	External regenerative resistor	REGIST-□...□W□...B, REGIST-500CW□...□B	Used for special operations, such as high frequency applications that require greater power dissipation than that provided by the servo amplifier's built-in regenerative resistor	p. 133
15	Safety unit, safety PLC, etc.	To be provided by the customer	Connects I/O signals from the Safe Torque Off function to devices such as the safety unit and safety PLC.	—
16	Molded case circuit breaker (MCCB)	To be provided by the customer	Used to protect the power line.	—
17	Noise filter	To be provided by the customer	Used to prevent external noise from the power source line.	—
18	Electromagnetic contactor	To be provided by the customer	Used to switch the power on and off.	—
19	Brake power	To be provided by the customer	Used for servo motors with brake	—

Connector sets are also available with set model numbers. See respective pages.

System Configuration

100 to 150 A The photograph shows the 100 A model.

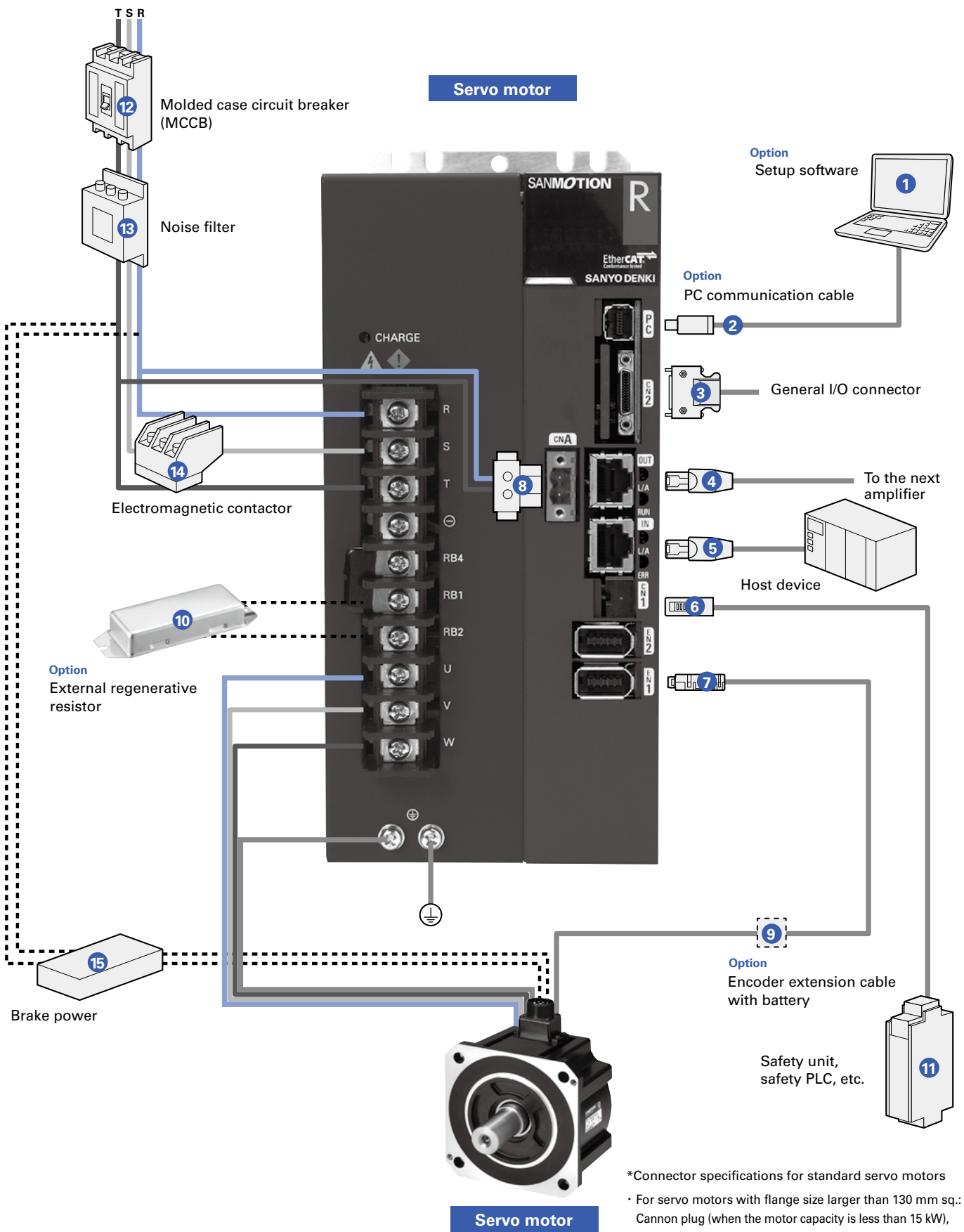

*Connector specifications for standard servo motors
 · For servo motors with flange size larger than 130 mm sq.:
 Cannon plug (when the motor capacity is less than 15 kW),
 Terminal block (when the motor capacity is more than 20 kW)

Options and Peripherals (100 to 150 A)

No.	Name	Model no.	Description	Page
1	Setup software	Can be downloaded from Product Information on our website.	Parameters can be set and monitored via communication with a PC.	p. 120
2	PC communication cable	AL-00689703-01	PC communication cable for setup software	p. 131
3	CN2 connector	AL-00842383	General I/O connector	p. 125
4	OUT connector	To be provided by the customer	EtherCAT OUT (to the next amplifier)	—
5	IN connector	To be provided by the customer	EtherCAT IN (host device)	—
6	CN1 connector	AL-00718252-01	To connect safety device	p. 125
7	EN1, EN2 connectors	AL-00632607	To connect to encoders	p. 125
8	CNA connector	AL-Y0005159-01	For control circuit power supply input	p. 125
9	Encoder extension cable with battery	AL-00697960-□□	Used when using a battery-backup method absolute encoder	p. 132
10	External regenerative resistor	REGIST-□□…□W□□…B, REGIST-500CW□□…□B	Used for special operations, such as high frequency applications that require greater power dissipation than that provided by the servo amplifier's built-in regenerative resistor	p. 133
11	Safety unit, safety PLC, etc.	To be provided by the customer	Connects I/O signals from the Safe Torque Off function to devices such as the safety unit and safety PLC.	—
12	Molded case circuit breaker (MCCB)	To be provided by the customer	Used to protect the power line.	—
13	Noise filter	To be provided by the customer	Used to prevent external noise from the power source line.	—
14	Electromagnetic contactor	To be provided by the customer	Used to switch the power on and off.	—
15	Brake power	To be provided by the customer	Used for servo motors with brake	—

Connector sets are also available with set model numbers. See respective pages.

System Configuration

300 A

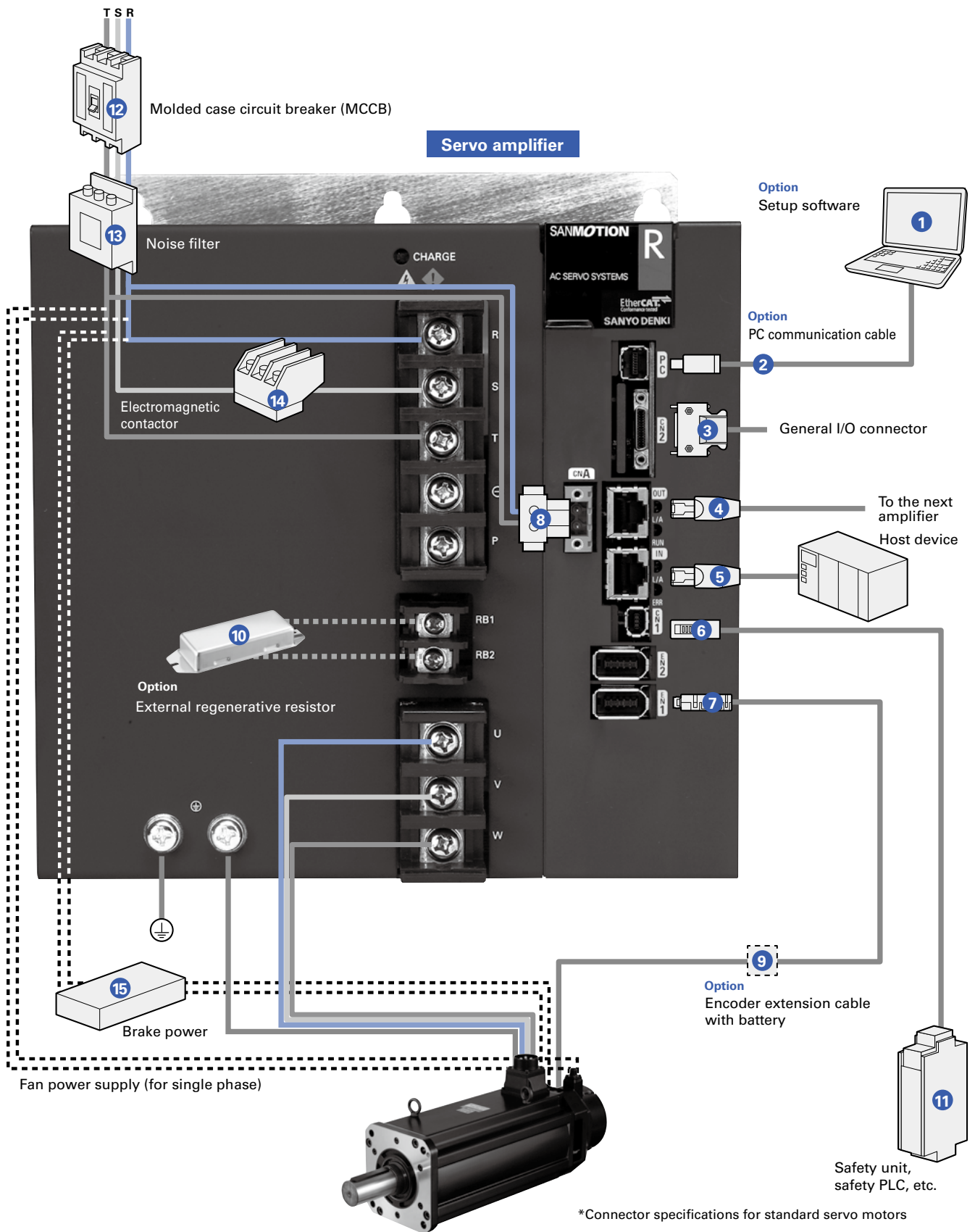

Servo motor

*Connector specifications for standard servo motors
 · For servo motors with flange size larger than 130 mm sq.:
 Cannon plug (when the motor capacity is less than 15 kW),
 Terminal block (when the motor capacity is more than 20 kW)

Options and Peripherals (300 A)

No.	Name	Model no.	Description	Page
1	Setup software	Can be downloaded from Product Information on our website.	Parameters can be set and monitored via communication with a PC.	p. 120
2	PC communication cable	AL-00689703-01	PC communication cable for setup software	p. 131
3	CN2 connector	AL-00842383	General I/O connector	p. 125
4	OUT connector	To be provided by the customer	EtherCAT OUT (to the next amplifier)	—
5	IN connector	To be provided by the customer	EtherCAT IN (host device)	—
6	CN1 connector	AL-00718252-01	To connect safety device	p. 125
7	EN1, EN2 connectors	AL-00632607	To connect to encoders	p. 125
8	CNA connector	AL-Y0005159-01	For control circuit power supply input	p. 125
9	Encoder extension cable with battery	AL-00697960-□□	Connected when using a battery-backup method absolute encoder	p. 132
10	External regenerative resistor	REGIST-□...□W□...B, REGIST-500CW□...□B	Used for special operations, such as high frequency applications that require greater power dissipation than that provided by the servo amplifier's built-in regenerative resistor	p. 133
11	Safety unit, safety PLC, etc.	To be provided by the customer	Connects I/O signals from the Safe Torque Off function to devices such as the safety unit and safety PLC.	—
12	Molded case circuit breaker (MCCB)	To be provided by the customer	Used to protect the power line.	—
13	Noise filter	To be provided by the customer	Used to prevent external noise from the power source line.	—
14	Electromagnetic contactor	To be provided by the customer	Used to switch the power on and off.	—
15	Brake power	To be provided by the customer	Used for servo motors with brake	—

Connector sets are also available with set model numbers. See respective pages.

General Specifications

Control function	Position control/Speed control/Torque control (Parameter switching)	
Control system	IGBT: PWM control, sinusoidal drive (MOS-FET: PWM control, sinusoidal drive)	
Main Circuit Power Supply *1	3-Phase: 200 to 230 VAC +10, -15%, 50/60 Hz±3 Hz Single-phase: 200 to 230 VAC +10, -15%, 50/60 Hz±3 Hz *2 Single-phase: 100 to 115 VAC +10, -15%, 50/60 Hz±3 Hz *3	
Control circuit power supply *1	Single-phase: 200 to 230 VAC +10, -15%, 50/60 Hz±3 Hz Single-phase: 100 to 115 VAC +10, -15%, 50/60 Hz±3 Hz *3	
Environment	Ambient temperature	0 to +55°C
	Storage temperature	-20 to +65°C
	Operation and Storage humidity	Below 90%RH (non-condensing)
	Operation altitude	Below 1000 m
	Vibration resistance	5 m/s ² freq. range 10 to 55 Hz tested for 2 hours in each X, Y and Z-axis directions
	Impact resistance	20 m/s ²
Structure	Built-in tray type power supply	

*1
Power source voltage should be within the specified range below.
[200 VAC power input type]:
Specified power supply range = 170 to 253 VAC
[100 VAC power input type]:
Specified power supply range = 85 to 127 VAC *2
The 200 VAC single-phase input type is compatible only with RS2□01 (15 A), RS2□03 (30 A), RS2□05 (50 A). Please set parameters before using single-phase input. *3
The 100 VAC single-phase input type is compatible only with RS2□01 (15 A), RS2□03 (30 A). Please set parameters before using single-phase input.



Performance

Speed control range	1:5000 (Internal speed command)
Frequency characteristics	800 Hz
Permissible load moment of inertia	10 times the motor rotary inertia

Built-in functions

Protection functions	Overcurrent, Current detection error, Overload, Regeneration error, Magnetic pole position estimation error, Amplifier overheating, External error, Overvoltage, Main circuit power supply undervoltage, Main circuit power supply open phase, Control circuit power supply undervoltage, Encoder error, Overspeed, Speed control error, Speed feedback error, Excessive position deviation, Position command pulse error, Built-in memory error, Parameter error
Digital operator	Status display, Monitor display, Alarm display, Test run, Adjustment mode
Dynamic brake circuit	Built in/None selectable
Regenerative resistor	15 to 150A: Built in/None selectable, 300 A: None *For all models from 15 to 300 A, optional external resistors can be equipped.
Monitor	Speed monitor (VMON) 2.0 V±10% (at 1000 min ⁻¹), Torque (thrust force) command monitor (TCMON) 2.0 V±10% (at 100%)

Safety standards

Servo amplifier type	Safety standards		
All models	North American safety standards (UL ratings)	UL508C	
	European directive	Low-voltage directive	EN61800-5-1
		EMC directive	EN61000-6-2, EN61800-3, EN61326-3-1
	KC Mark (Korea Certification Mark)	KN61000-6-2, KN61000-6-4	
Safety feature standards	IEC 61508: SIL2, ISO 13849-1 Cat.3: PL=d, IEC 62061: SILCL2		

EtherCAT interface type specifications

Physical layer	IEC61158-2 IEEE802.3u 100BASE-TX
Data link layer	IEC61158-3, -4Type12
Application layer	IEC61158-5, -6Type12
Device profile	IEC61800-7 Profile type1 (CiA402) ·CoE (CANopen over EtherCAT) ·FoE (File access over EtherCAT)
Communication port	RJ45 connector (2 ports)
Bit rate	100 Mbps (Full duplex)
Max. number of nodes	65535 nodes
Transmission distance/Topology	Max. 100 m (between nodes)/Daisy chain
Communication cable	Twisted pair CAT5e (straight-through or crossover)
Communication object	SDO (Service Data Object), PDO (Process Data Object)
Synchronization type	SYNC0 event synchronization, SYNC1 event synchronization, Asynchronous
Operation modes	Profile position mode, Profile velocity mode, Profile torque mode, Homing mode, Cycle sync position mode, Cycle sync velocity mode, Cycle sync torque mode
LED indicator	Port 0/1 link display, RUN display, ERROR display
General I/O	Input x 6, output x 2 (total of 8)

Dimensions [Unit : mm]

15 A

Mass: Without built-in regenerative resistor 0.7 kg
 With built-in regenerative resistor 0.75 kg

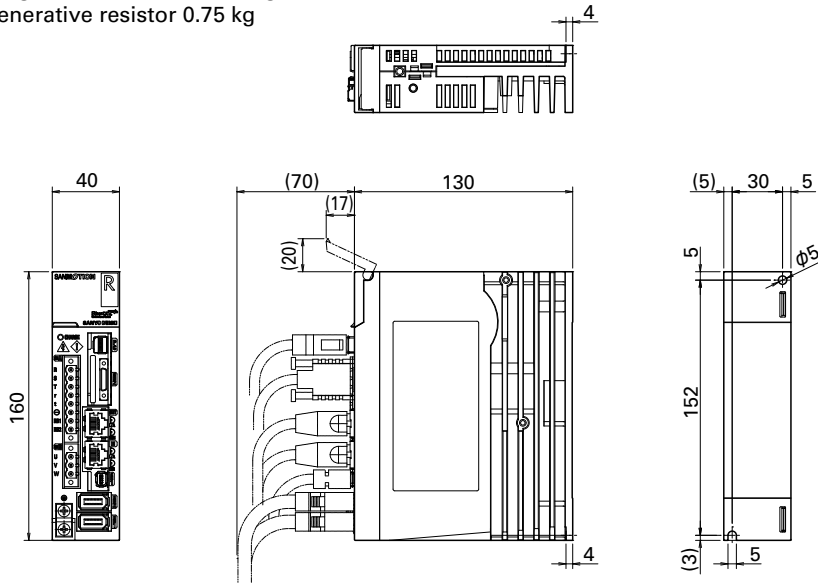

30 A

Mass: Without built-in regenerative resistor 0.9 kg
 With built-in regenerative resistor 0.95 kg

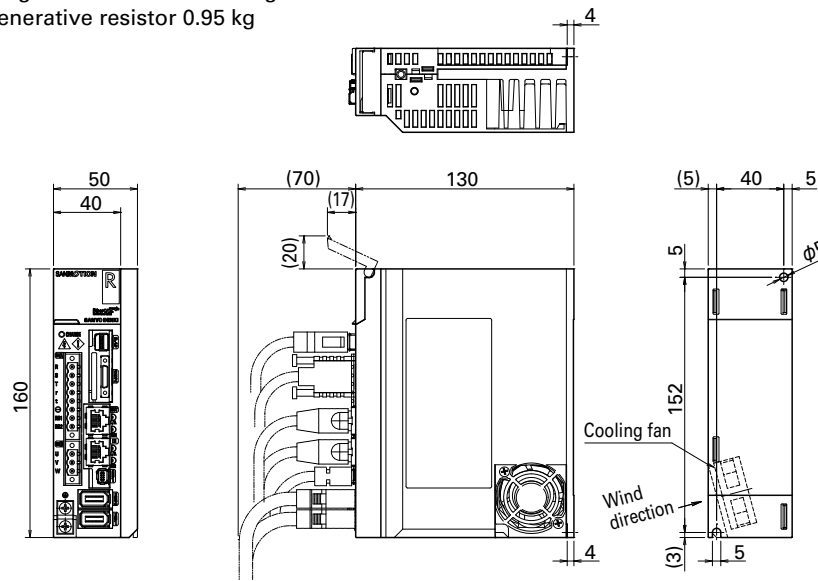

50 A

Mass: Without built-in regenerative resistor 1.6 kg
 With built-in regenerative resistor 1.65 kg

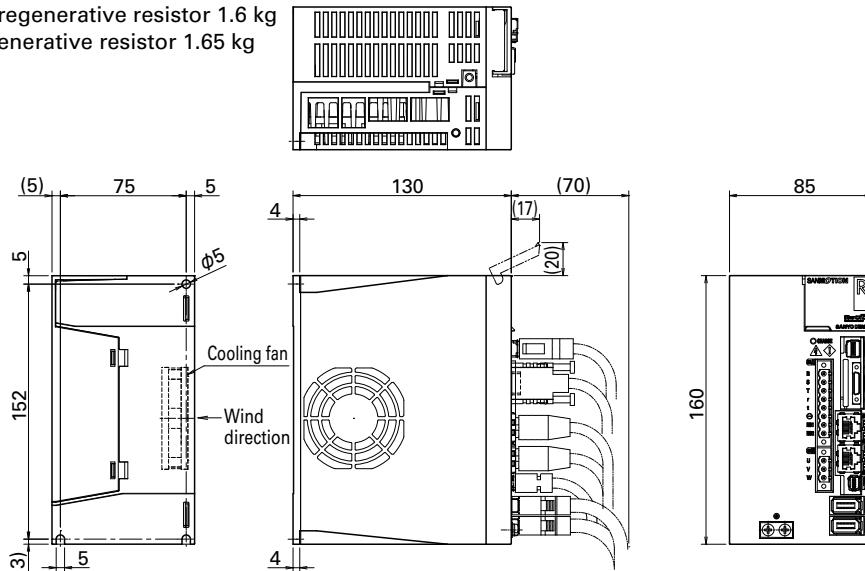

Dimensions [Unit: mm]

100 A

Mass: Without built-in regenerative resistor 4.8 kg
 With built-in regenerative resistor 5.0 kg

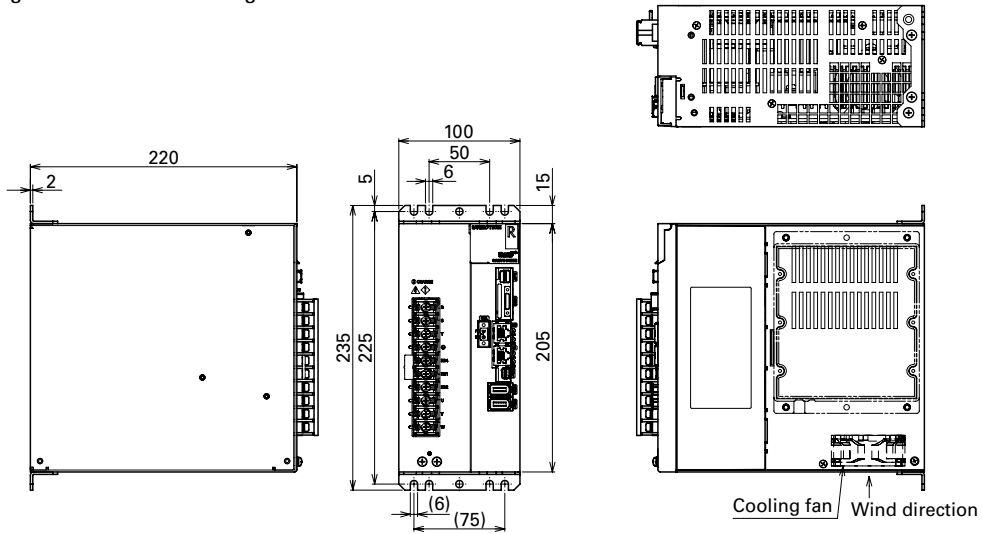

150 A

Mass: Without built-in regenerative resistor 5.1 kg
 With built-in regenerative resistor 5.3 kg

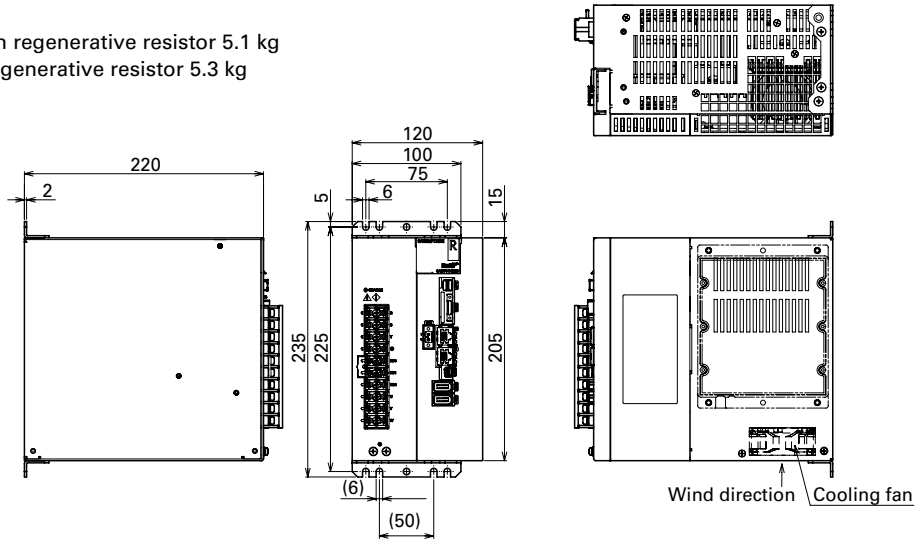

300 A

Mass: Without built-in regenerative resistor 9.6 kg

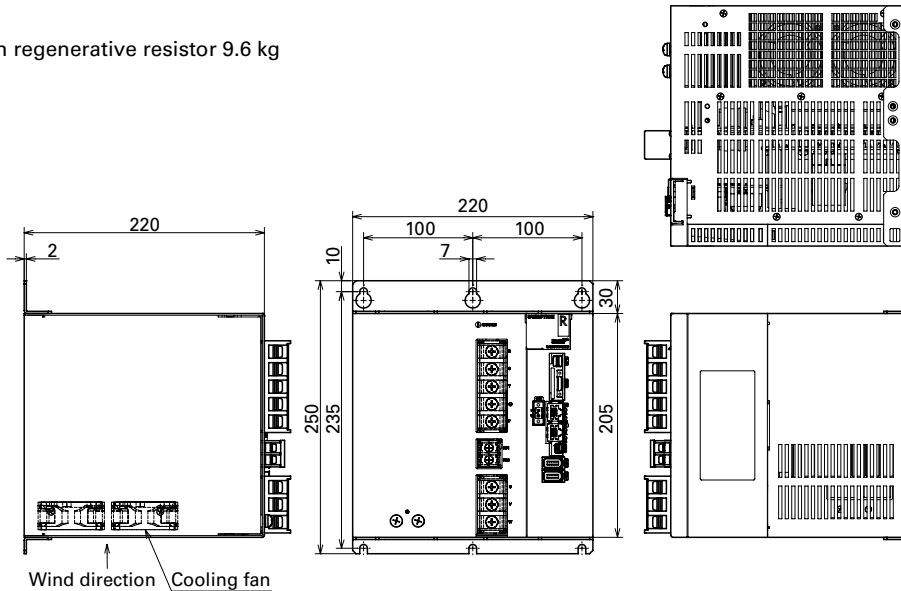

External Wiring Diagram

15 to 300 A

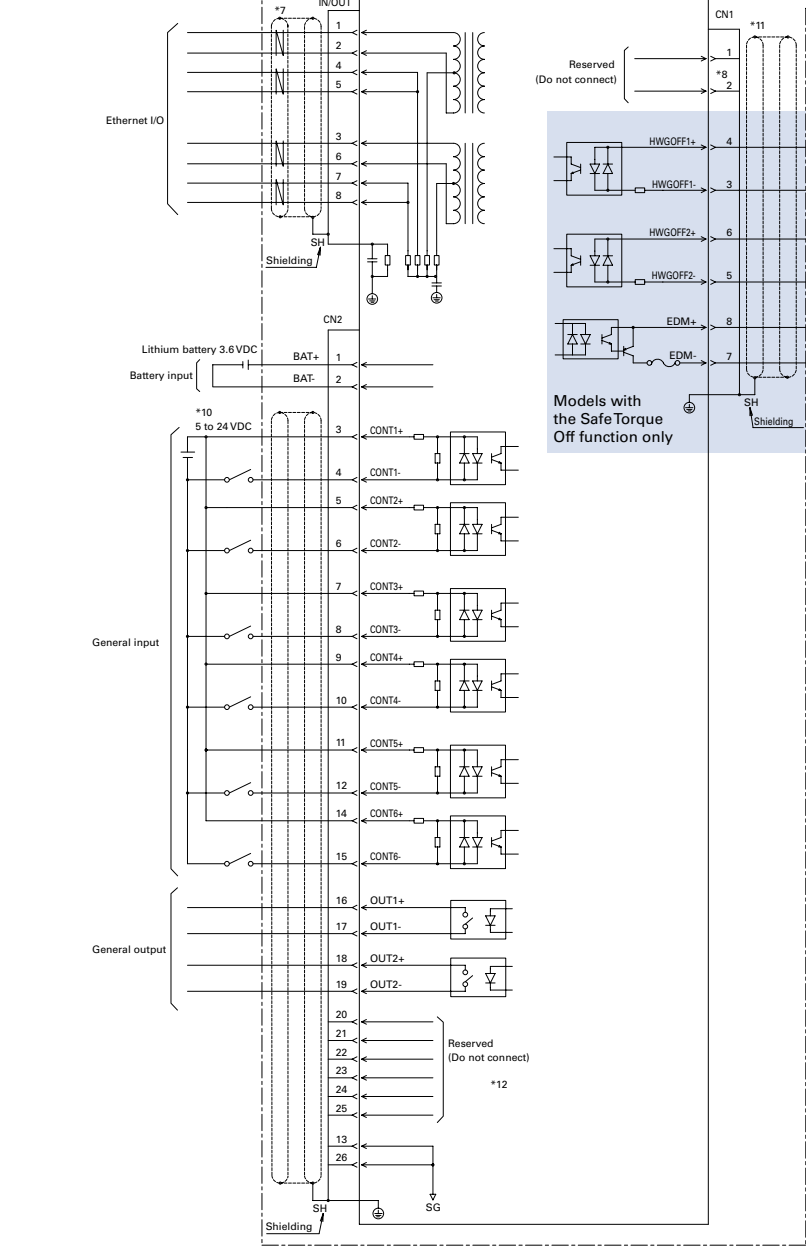
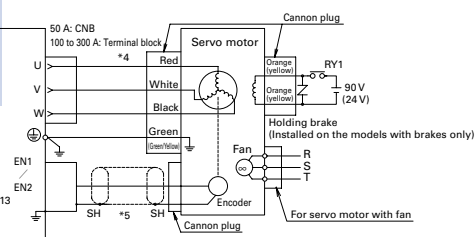
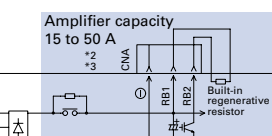
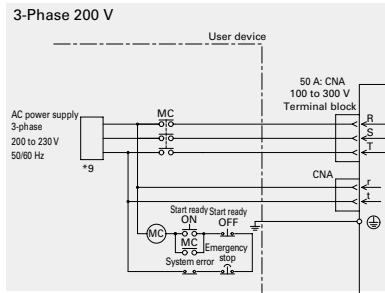
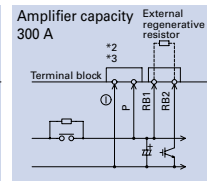
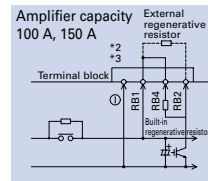
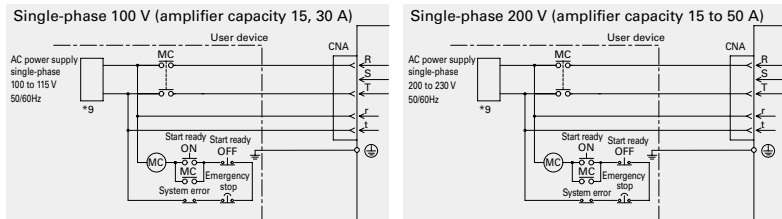

Connector No.	Name	Housing, plug, shell
CNA 15 to 50 A	Main power supply, Control circuit power supply input connector	MSTBT2.5/8-STF-5.08LUB
CNA 100 A, 150 A, 300 A	Control circuit power supply input connector	MSTBT2.5/2-STF-5.08
CNB 15 to 50 A	Servo motor power line connector	MSTBT2.5/3-STF-5.08
EN1/EN2	Encoder signal connector	Connector: 36210-0100PL Shell kit: 36310-3200-008
CN2	General I/O signal battery power supply connector	Connector: HDR-E26MSG1+ Shell kit: HDR-E26LPH
CN1	Safe Torque Off function signal connector	2013595-3

- *1 Use a shielded twisted pair cable.
- *2 For amplifier capacity 15 A, 30 A, 50 A: Connect the external regenerative resistor "between the RB1 and RB2 terminals". When using an external regenerative resistor, remove the built-in regenerative resistor wiring that is connected to the RB1 terminal and RB2 terminal and then connect the external regenerative resistor "between the RB1 and RB2 terminals".
For amplifier capacity 100 A, 150 A: When using a built-in regenerative resistor, short circuit "between the RB1 and RB4 terminals". When using an external regenerative resistor, remove the short bar that is connected to the RB1 terminal and RB4 terminal and then connect the regenerative resistor "between the RB1 and RB2 terminals".
For amplifier capacity 300 A: Connect the regenerative resistor "between the RB1 and RB2 terminals".
- *3 ⊖ and P (300 A only) terminals are used for maintenance (high-voltage circuits). Do not wire to this terminal.
- *4 The motor side connections vary with motor specifications. The indications of red, white, black, green and orange apply when the motor power and brake lines are the lead type. When they are the cannon plug type, connect them according to the motor specifications.
- *5 Refer to the encoder wiring diagram for the wiring of the connector for the encoder connection.
- *6 R, S, T, r, t, ⊖, P (300 A only), RB1, RB2, RB4 (100 A and 150 A only), U, V, and W are high-voltage circuits. Other signal lines are low-voltage circuits. When wiring, ensure that there is a sufficient distance between the high- and low-voltage circuits.
- *7 Use a category 5e (TIA standards) or above shielded twisted pair cable (STP).
- *8 Do not connect anything to CN1-1 and Pin 2.
- *9 Installing an earth leakage circuit breaker conforming either to UL, IEC, or EN standards is recommended. Do not connect the S phase for the single-phase power supply amplifier.
- *10 The external power supply is to be provided by the customer.
- *11 CN1 is a connector for the Safe Torque Off function. To turn the servo motor power ON, a safety function must be connected and the wiring to activate the Safe Torque Off function must be done.
- *12 Do not connect anything to CN2-20 to 25.
- *13 When using a pulse encoder in a semi-closed system, connect to EN2.

Encoder Wiring Diagram

Serial Encoder

Battery-less optical absolute encoder [Model No. HA035]

Optical absolute encoder for incremental systems [Model No. PA035S]

Option: Optical battery-backup method absolute encoder [Model No. PA035C]

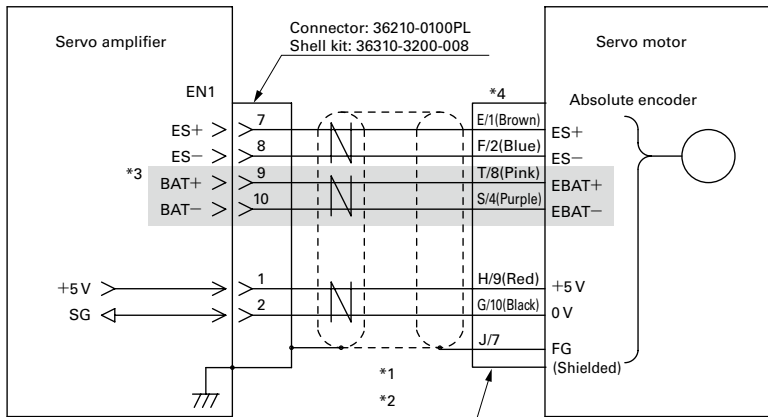

Cannon plug model no. _____

Flange size: 130 mm sq. or larger	JN2DS10SL1-R	JN2FS10SL1-R
	JN2DS10SL2-R	JN2FS10SL2-R
	JN2DS10SL3-R	JN2FS10SL3-R

- *1 Use a shielded twisted pair cable.
- *2 Maximum cable lengths by conductor size of the power supply cable (5V, SG) are shown in the table below.

Conductor size		Conductor resistance (Ω/km) *at 20°C	Length (m)
AWG	SQ (mm ²)		
26	0.15	150 or less	5
24	0.2	100 or less	10
22	0.3	60 or less	15
20	0.5	40 or less	25
18	0.75	25 or less	40

*Conductor resistance differs by conductor specifications.

- *3 Battery lines (EBAT+, EBAT-) are necessary only when a battery-backup method absolute encoder is used.
- *4 Lead wire colors are indicated in parentheses. For lead wire colors and cannon plug pin numbers, see the following table.

	ES+	ES-	EBAT+	EBAT-	+5V	0V	FG
100 mm sq. or smaller	Brown	Blue	Pink*3	Purple*3	Red	Black	Shielded
130 mm sq. or larger	1	2	8*3	4*3	9	10	7

Option: Pulse Encoder

Wire-saving incremental encoder

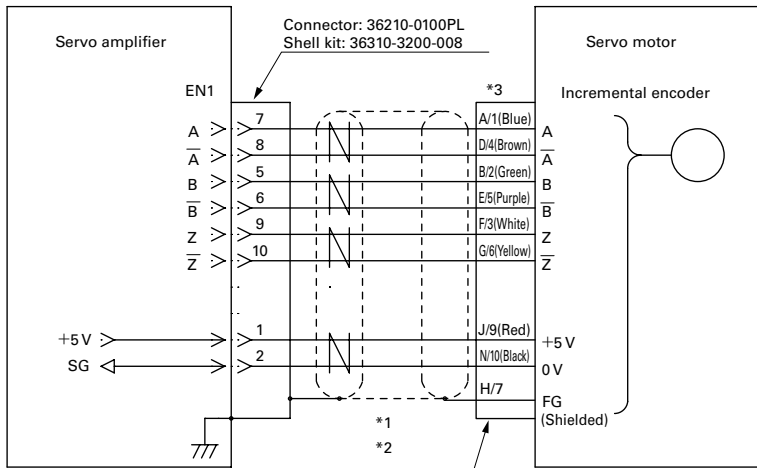

Cannon plug model no. _____

Flange size: 130 mm sq. or larger	JN2DS10SL1-R	JN2FS10SL1-R
	JN2DS10SL2-R	JN2FS10SL2-R
	JN2DS10SL3-R	JN2FS10SL3-R

- *1 Use a shielded twisted pair cable.
- *2 Maximum cable lengths by conductor size of the power supply cable (5V, SG) are shown in the table below.

Conductor size		Conductor resistance (Ω/km) *at 20°C	Length (m)
AWG	SQ (mm ²)		
26	0.15	150 or less	5
24	0.2	100 or less	10
22	0.3	60 or less	15
20	0.5	40 or less	25
18	0.75	25 or less	40

*Conductor resistance differs by conductor specifications.

- *3 Lead wire colors are indicated in parentheses. For lead wire colors and cannon plug pin numbers, see the following table:

	A	Ā	B	B̄	Z	Z̄	+5V
100 mm sq. or smaller	Blue	Brown	Green	Purple	White	Yellow	Red
130 mm sq. or larger	1	4	2	5	3	6	9
	0V		FG				
100 mm sq. or smaller	Black	Shielded					
130 mm sq. or larger	10	7					

Servo Amplifiers

R CANopen Interface type

Servo Amplifier Capacity: 15 to 50 A

Equipped with communication protocol “CANopen interface” well suited for embedded systems.



How to read model numbers

Note that not all the possible combinations of the numbers and characters below are valid. Also, some of the numbers/characters listed below are for optional models. For model numbers valid as standard products, refer to “Standard Model Number List”.

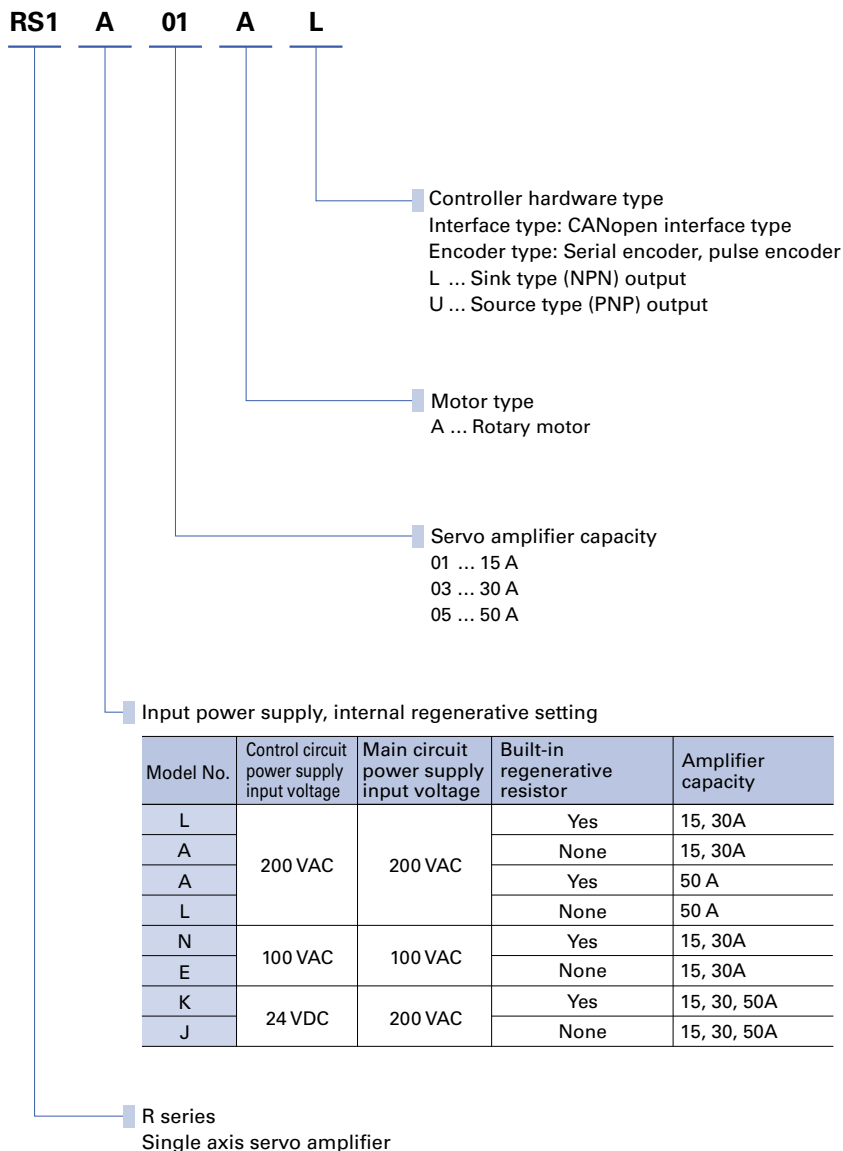

- Motor parameters need to be set for the amplifier before use. Please use the setup software for parameter setting.

Options and Peripherals (15 to 50 A)

No.	Name	Model no.	Description	Page
1	Setup software	Can be downloaded from Product Information on our website.	Parameters can be set and monitored via communication with a PC.	p. 120
2	PC communication cable	AL-00490833-01	PC communication cable for setup software	p. 131
3	CN3, CN4 connectors	To be provided by the customer	Connects controller, PC, and PLC (RJ45)	—
4	CN1 connector	AL-00608710	General I/O connector	p. 126
5	CN2 connector	AL-00385596	To connect to encoders	p. 126
6	CNA connector	AL-00329461-01	To connect input power supply	p. 126
7	CNB connector	AL-Y0000988-01	To connect external regenerative resistor and DC reactor	p. 126
8	CNC connector	AL-00329458-01	To connect to servo motor	p. 126
9	Lithium battery	AL-00494635-01	Used when using a battery-backup method absolute encoder	p. 132
10	External regenerative resistor	REGIST-□□□□W□□□B, REGIST-500CW□□□B	Used for special operations, such as high frequency applications that require greater power dissipation than that provided by the servo amplifier's built-in regenerative resistor	p. 133
11	Electromagnetic contactor	To be provided by the customer	Used to switch the power on and off.	—
12	DC reactor	To be provided by the customer	Used to remove power line harmonics Remove the DL1-DL2 short bar and connect to remove harmonics.	—
13	Noise filter	To be provided by the customer	Used to prevent external noise from the power source line.	—
14	Molded case circuit breaker (MCCB)	To be provided by the customer	Used to protect the power line.	—
15	Brake power	To be provided by the customer	Used for servo motors with brake	—

General Specifications

Control function	CANopen interface type	
Control system	IGBT: PWM control, sinusoidal drive	
Main Circuit Power Supply *1	3-Phase: 200 to 230 VAC +10, -15%, 50/60 Hz±3 Hz	
	Single-phase: 200 to 230 VAC +10, -15%, 50/60 Hz±3 Hz *2	
	Single-phase: 100 to 115 VAC +10, -15%, 50/60 Hz±3 Hz *3	
Control circuit power supply *1	Single-phase: 200 to 230 VAC +10, -15%, 50/60 Hz±3 Hz	
	Single-phase: 100 to 115 VAC +10, -15%, 50/60 Hz±3 Hz *3 24 VDC+15, -15%	
Environment	Ambient temperature	0 to +55°C
	Storage temperature	-20 to +65°C
	Operation and Storage humidity	Below 90%RH (non-condensing)
	Operation altitude	Below 2000 m
	Vibration resistance	0.5 G freq. range 10 to 55 Hz tested for 2 hours in each X, Y and Z-axis directions
	Impact resistance	2 G
Structure	Built-in tray type power supply	

*1
Power source voltage should be within the specified range below.
[200 VAC power input type]:
Specified power supply range = 170 to 253 VAC
[100 VAC power input type]:
Specified power supply range = 85 to 127 VAC

*2
The 100 VAC single-phase input type is an option.
Only corresponds to 15 and 30 A.
Please set parameters before using single-phase input.



Performance

Speed control range	1:5000
Frequency characteristics	600 Hz (JL=JM)
Permissible load moment of inertia	10 times the motor rotary inertia

Built-in functions

Protection functions	Overcurrent, Current detection error, Overload, Regeneration error, Amplifier overheating, External overheating, Overvoltage, Main circuit power supply undervoltage, Main power supply open phase, Control circuit power supply error, Encoder error, Overspeed, Speed control error, Speed feedback error, Excessive position deviation, Position command pulse error, CPU error, Built-in memory error, Battery error, Parameter error
Digital operator	Status display, Monitor display, Alarm display, Test run, Adjustment mode
Dynamic brake circuit	Built in/None selectable
Regenerative resistor	Built in/None selectable *For all models from 15 to 50 A, optional external resistors can be equipped.
Monitor	Speed monitor (VMON) 2.0 V±10% (at 1000 min ⁻¹), Torque (thrust force) command monitor (TCMON) 2.0 V±10% (at 100%)

Safety standards

Safety standards	North American safety standards (UL ratings)	UL508C
	European directive	EN50178, EN61000-6-2, EN61800-3

CANopen Interface Type Specifications

Fieldbus specifications

Bus connection, Medium	CAN standards ISO-11898 (high-speed CAN)	
Fieldbus	CANopen	
Communication profile	CiA DS301 Version 4.02	
Device profile	CiA DSP402 (CANopen device profile for drive and motion control applications) Version 2.0	
Bit rate	1 Mbps, 800 kbps, 500 kbps (factory setting), 250 kbps, 125 kbps, 50 kbps, 20 kbps, 10 kbps (select using the setup software)	
Max. number of nodes per segment	1 to 127 (two 16 positions, rotary switch, or select using the setup software)	
Connector	RJ-45 type modular connector (2 ports) - Pin 1 "CAN_H" bus line, H side - Pin 2 "CAN_L" bus line, L side - Pin 3, Pin 7 "CAN_GND" Ground - Pin 6 "CAN_SHIELD" cable shield - Pin 5 "Terminator" (120Ω; if termination is required, connect a jumper wire between the Pin 1 and Pin 5)	
Transceiver	ISO-11898 compliant high-speed transceiver	
Max. bus length	25 m (max. bus length at 1 Mbps)	
Communication object	SDO (Service Data Object: 1 SDO) PDO (Process Data Object: 4 transmit PDOs and 4 receive PDOs) EMCY (Emergency Message) NMT (Network Management) SYNC (Synchronization message) Heartbeat	
PDO transmission mode	Synchronous transmission mode	Asynchronous transmission mode
Operation modes	Homing mode (h.m) Profile Velocity mode (p.v) Profile Torque mode (t.q)	Profile Position mode (p.p) Interpolated Position mode (i.p)

General-purpose output specifications

Sink type (NPN)

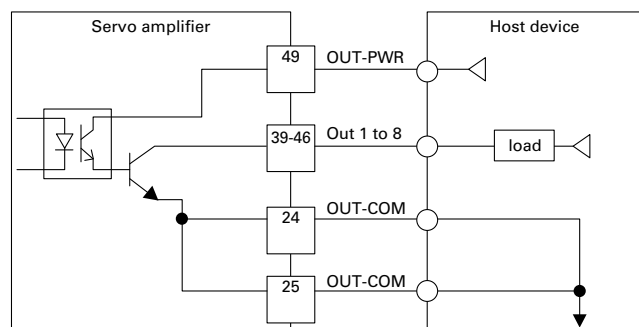

Source type (PNP)

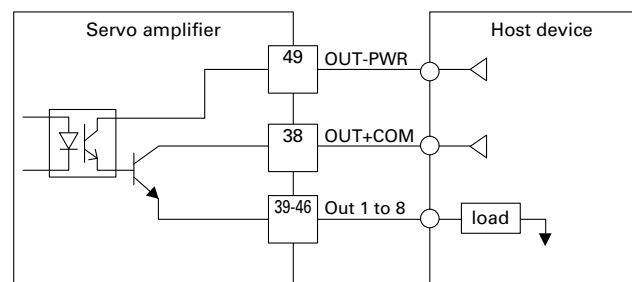

Dimensions [Unit: mm]

15 A

Mass: 1.0 kg

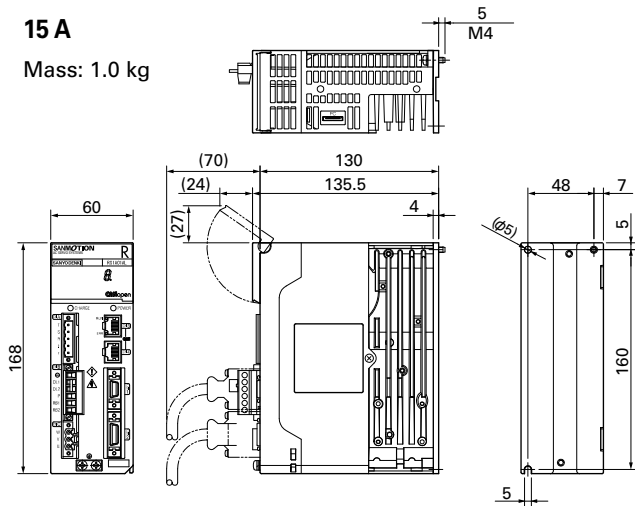

30 A

Mass: 1.1 kg

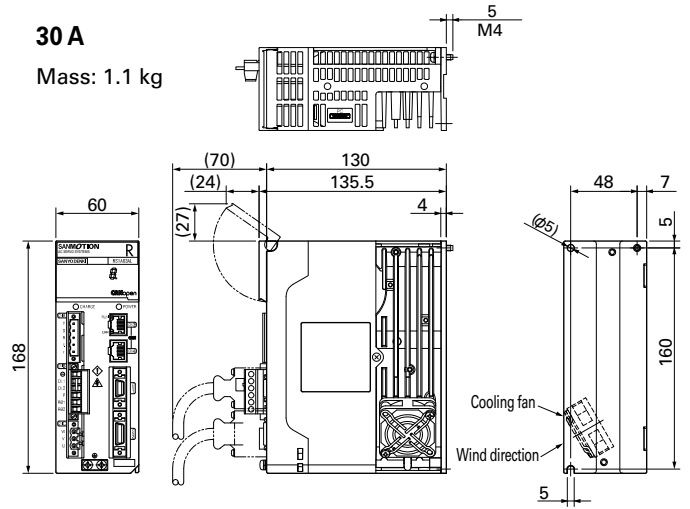

50 A

Mass: 2.3 kg

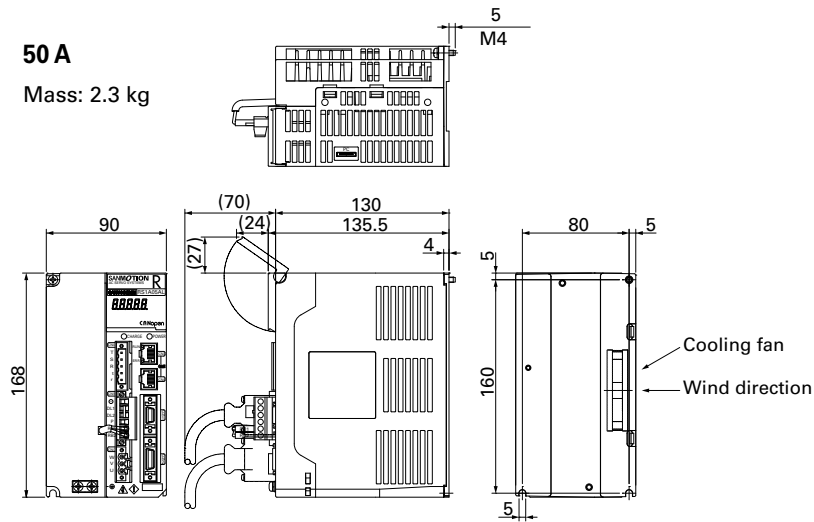

Connector layout is different for 24 VDC control circuit power supply.

External Wiring Diagram

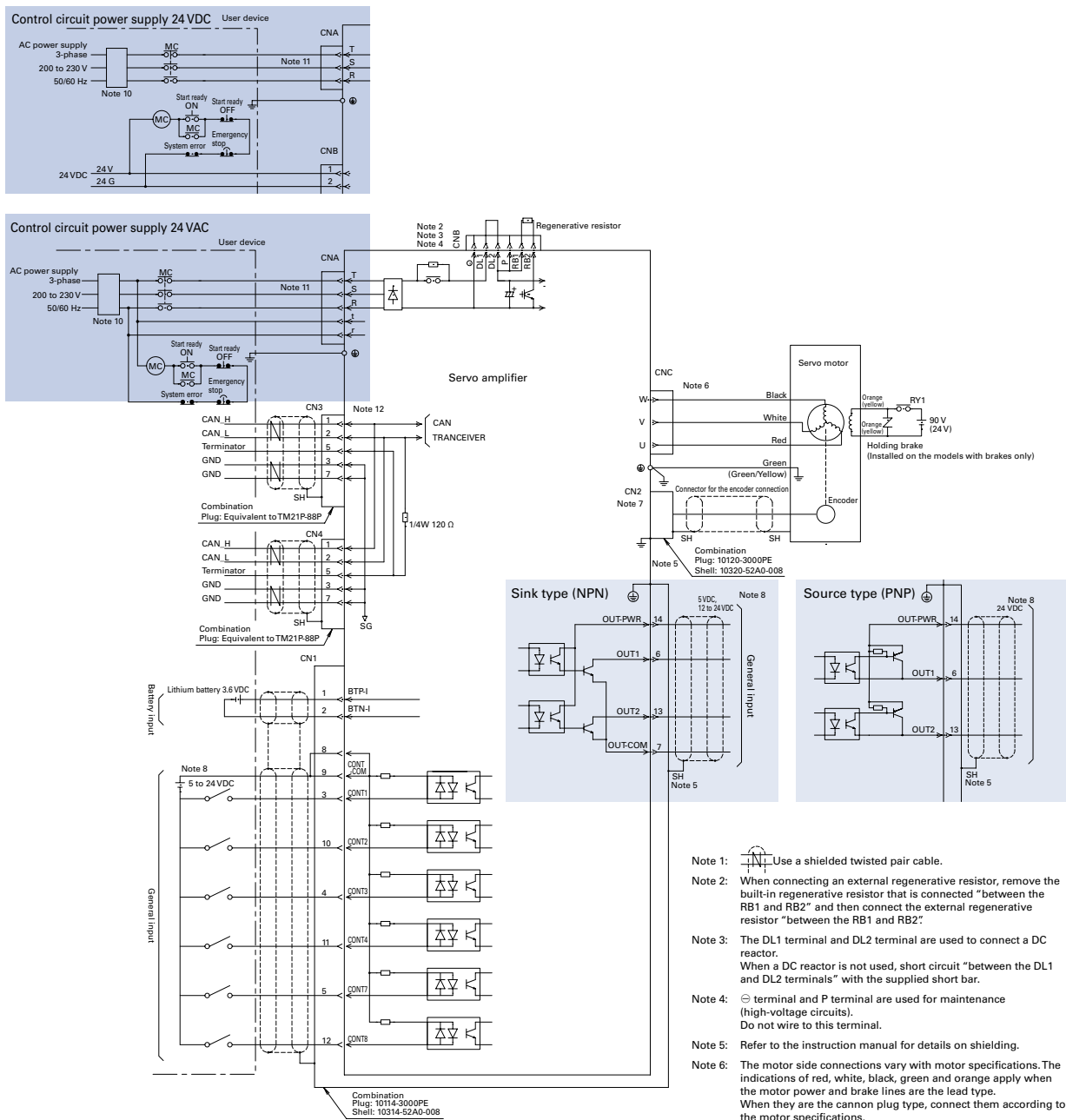

- Note 1: Use a shielded twisted pair cable.
- Note 2: When connecting an external regenerative resistor, remove the built-in regenerative resistor that is connected "between the RB1 and RB2" and then connect the external regenerative resistor "between the RB1 and RB2".
- Note 3: The DL1 terminal and DL2 terminal are used to connect a DC reactor. When a DC reactor is not used, short circuit "between the DL1 and DL2 terminals" with the supplied short bar.
- Note 4: terminal and P terminal are used for maintenance (high-voltage circuits). Do not wire to this terminal.
- Note 5: Refer to the instruction manual for details on shielding.
- Note 6: The motor side connections vary with motor specifications. The indications of red, white, black, green and orange apply when the motor power and brake lines are the lead type. When they are the cannon plug type, connect them according to the motor specifications.
- Note 7: Refer to the encoder wiring diagram for the wiring of the connector for the encoder connection.
- Note 8: The external power supply is to be provided by the customer.
- Note 9: R, S, T, r, t, , P, DL1, DL2, RB1, RB2, U, V, W are high-voltage circuits, other signal lines are low-voltage circuits. When wiring, ensure that there is a sufficient distance between the high- and low-voltage circuits.
- Note 10: Installing an earth leakage circuit breaker conforming either to UL, IEC, or EN standards is recommended.
- Note 11: Do not connect the S phase for the single-phase power supply amplifier.
- Note 12: When a termination resistor is required, insert the RJ45 connector with short-circuited Pin 1 (CAN_H) and Pin 5 (Terminator) into CN3 or CN4.

External Wiring Diagram

Serial Encoder

Optical absolute encoder for incremental systems [Model No. PA035S]

Option: Optical battery-backup method absolute encoder [Model No. PA035C]

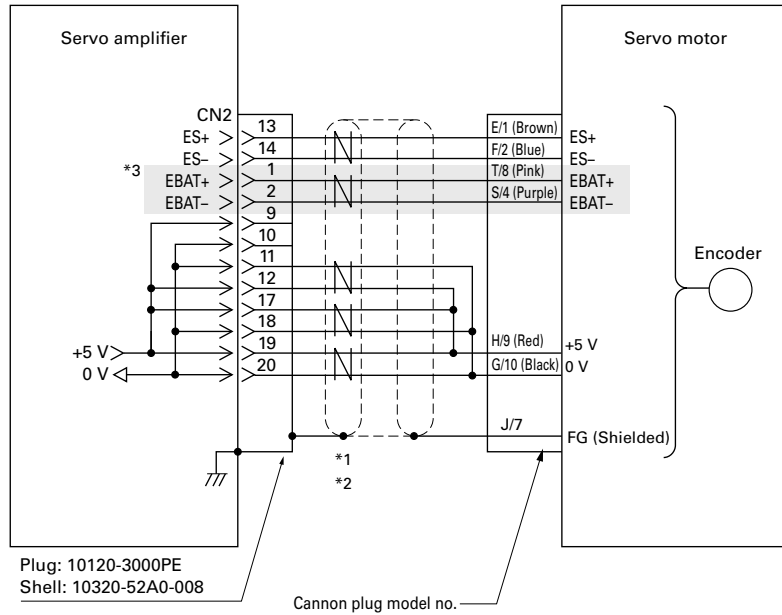

- *1 Use a shielded twisted pair cable.
- *2 Maximum cable lengths by conductor size of the power supply cable (5 V, SG) are shown in the table below.

Conductor size		Conductor resistance (Ω/km) *at 20°C	Length (m)
AWG	SQ (mm ²)		
26	0.15	150 or less	5
24	0.2	100 or less	10
22	0.3	60 or less	15
20	0.5	40 or less	25
18	0.75	25 or less	40

*Conductor resistance differs by conductor specifications.

- *3 Battery lines (EBAT+, EBAT-) are necessary only when a battery-backup method absolute encoder is used.
- *4 Lead wire colors are indicated in parentheses. For lead wire colors and cannon plug pin numbers, see the following table.

	ES+	ES-	EBAT+	EBAT-	+5V	0V	FG
100 mm sq. or smaller	Brown	Blue	Pink*3	Purple*3	Red	Black	Shielded
130 mm sq. or larger	1	2	8*3	4*3	9	10	7

Flange size: 130 mm sq. or larger	JN2DS10SL1-R	JN2FS10SL1-R
	JN2DS10SL2-R	JN2FS10SL2-R
	JN2DS10SL3-R	JN2FS10SL3-R

Option: Pulse Encoder

Wire-saving incremental encoder

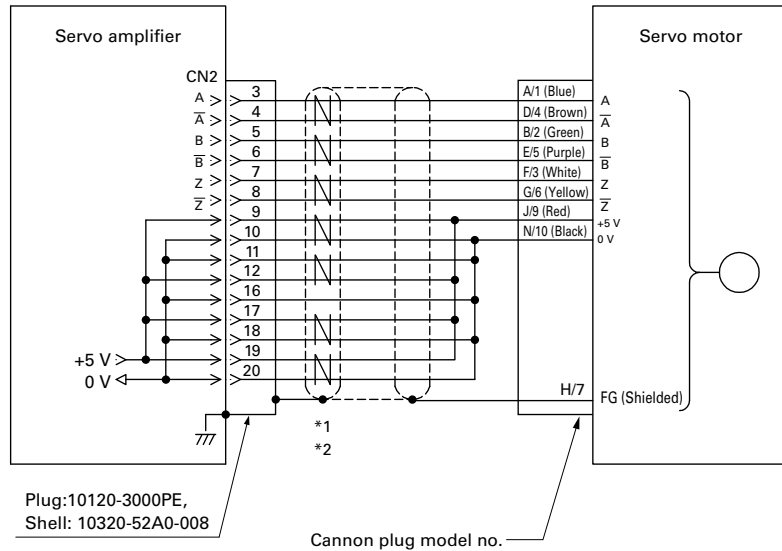

- *1 Use a shielded twisted pair cable.
- *2 Maximum cable lengths by conductor size of the power supply cable (5 V, SG) are shown in the table below.

Conductor size		Conductor resistance (Ω/km) *at 20°C	Length (m)
AWG	SQ (mm ²)		
26	0.15	150 or less	5
24	0.2	100 or less	10
22	0.3	60 or less	15
20	0.5	40 or less	25
18	0.75	25 or less	40

*Conductor resistance differs by conductor specifications.

- *3 Lead wire colors are indicated in parentheses. For lead wire colors and cannon plug pin numbers, see the following table:

	A	Ā	B	B̄	Z	Z̄	+5V
100 mm sq. or smaller	Blue	Brown	Green	Purple	White	Yellow	Red
130 mm sq. or larger	1	4	2	5	3	6	9

Flange size: 130 mm sq. or larger	JN2DS10SL1-R	JN2FS10SL1-R
	JN2DS10SL2-R	JN2FS10SL2-R
	JN2DS10SL3-R	JN2FS10SL3-R

	0V	FG
100 mm sq. or smaller	Black	Shielded
130 mm sq. or larger	10	7

Servo Amplifiers

R Built-in Positioning Function type

Servo Amplifier Capacity: 15 to 300 A

The need for a positioning control unit is eliminated, simplifying the system. There are two types of interfaces: DIO (Digital I/O) type and RS-485 communication type. RS-485 communication protocol is compatible with MODBUS communication and AE-LINK communication.



How to read model numbers

Note that not all the possible combinations of the numbers and characters below are valid. Also, some of the numbers/characters listed below are for optional models. For model numbers valid as standard products, refer to "Standard Model Number List".

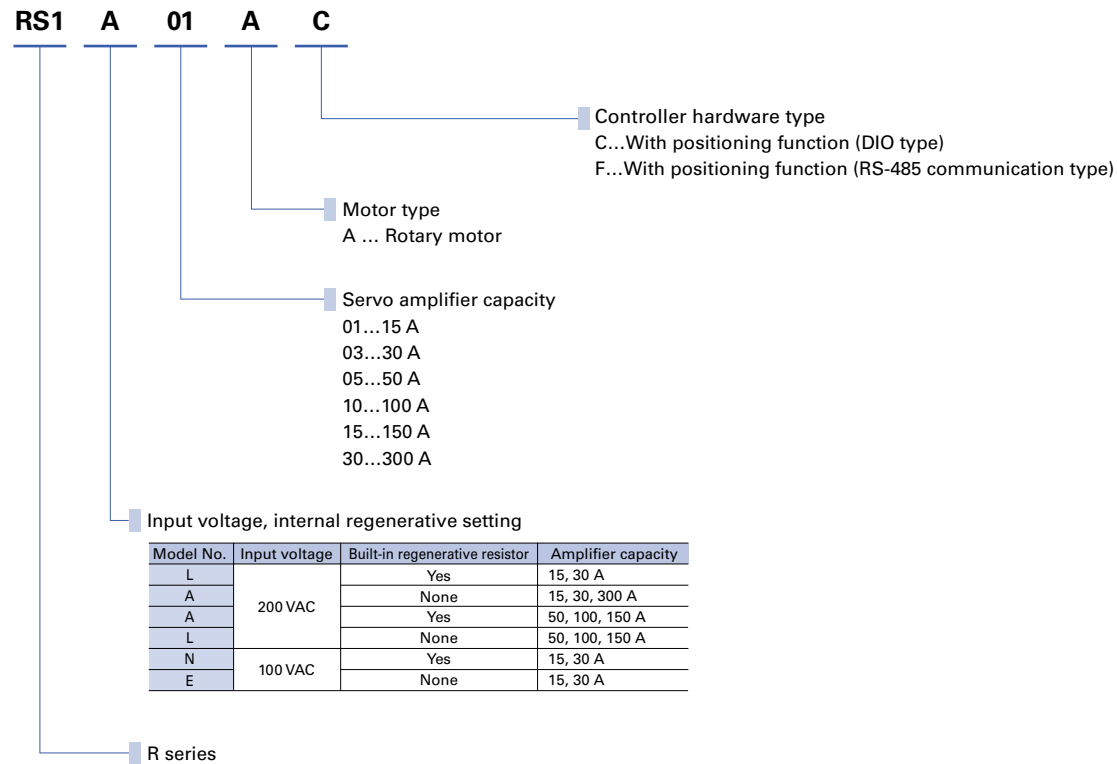

- Motor parameters need to be set for the amplifier before use. Please use the setup software for parameter setting.

System Configuration

15 to 50 A DIO type The photograph shows the 15 A model.

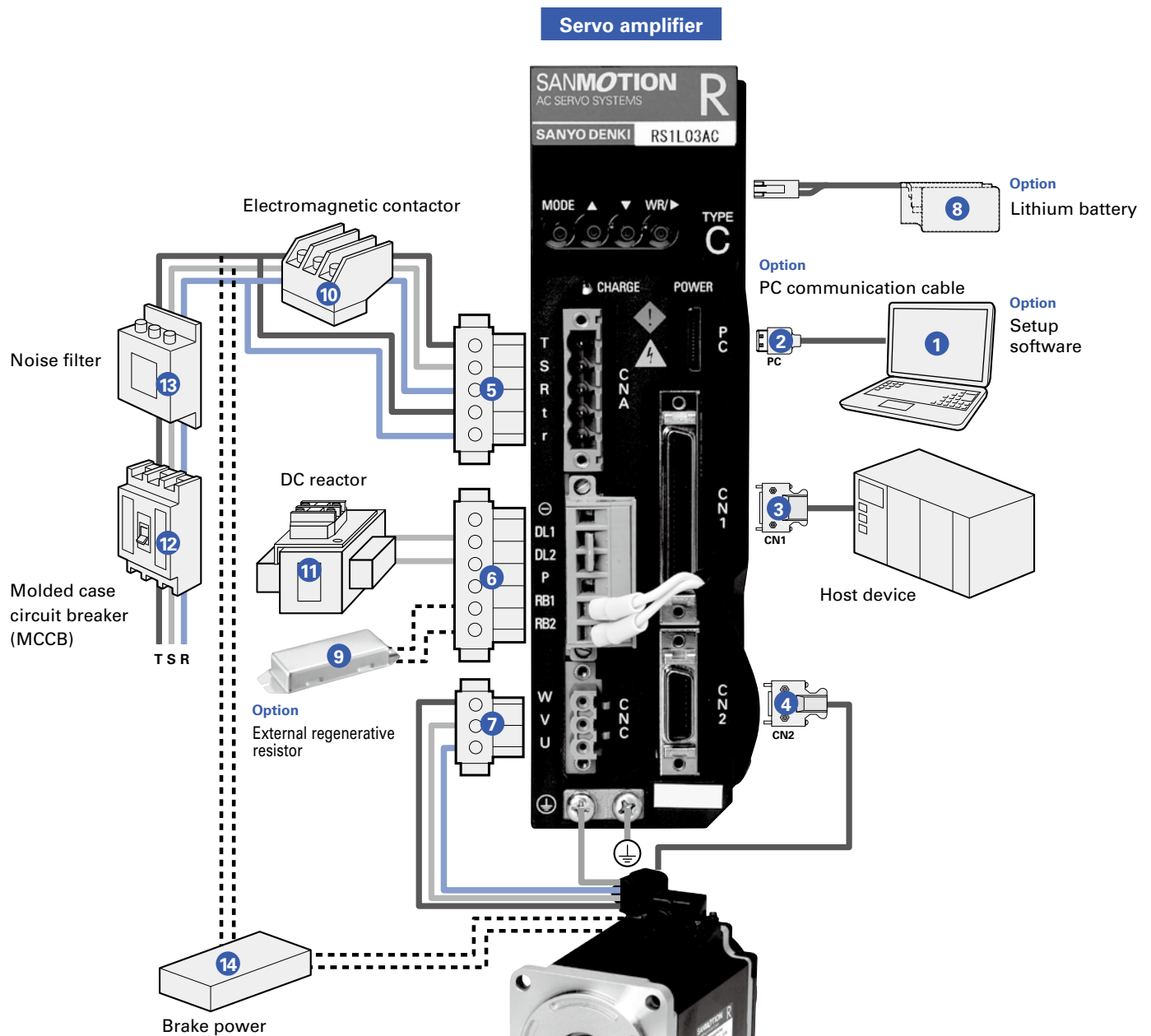

*Connector specifications for standard servo motors

- For servo motors with flange size smaller than 100 mm sq.: Cable without connector. (when servo motors are smaller than 80 mm sq., a cable with a connector is available as an option. Refer to p. 138)
- For servo motors with flange size larger than 130 mm sq.: Cannon plug (when the motor capacity is less than 15 kW), Terminal block (when the motor capacity is more than 20 kW)

Options and Peripherals (15 to 50 A)

No.	Name	Model no.	Description	Page
1	Setup software	Can be downloaded from Product Information on our website.	Parameters can be set and monitored via communication with a PC.	p. 120
2	PC communication cable	AL-00490833-01	PC communication cable for setup software	p. 131
3	CN1 connector	AL-00385594	To connect to host device I/O	p. 127
4	CN2 connector	AL-00385596	To connect to encoders	p. 127
5	CNA connector	AL-00329461-01	To connect input power supply	p. 127
6	CNB connector	AL-Y0000988-01	To connect external regenerative resistor and DC reactor	p. 127
7	CNC connector	AL-00329458-01	To connect to servo motor	p. 127
8	Lithium battery	AL-00494635-01	Used when using a battery-backup method absolute encoder	p. 132
9	External regenerative resistor	REGIST-□□□□□W□□□□B, REGIST-500CW□□□B	Used for special operations, such as high frequency applications that require greater power dissipation than that provided by the servo amplifier's built-in regenerative resistor	p. 133
10	Electromagnetic contactor	To be provided by the customer	Used to switch the power on and off.	—
11	DC reactor	To be provided by the customer	Used to remove power line harmonics	—
12	Molded case circuit breaker (MCCB)	To be provided by the customer	Used to protect the power line.	—
13	Noise filter	To be provided by the customer	Used to prevent external noise from the power source line.	—
14	Brake power	To be provided by the customer	Used for servo motors with brake	—

Connector sets are also available with set model numbers. See respective pages.

System Configuration

100 to 300 A DIO type The photograph shows the 100 A model.

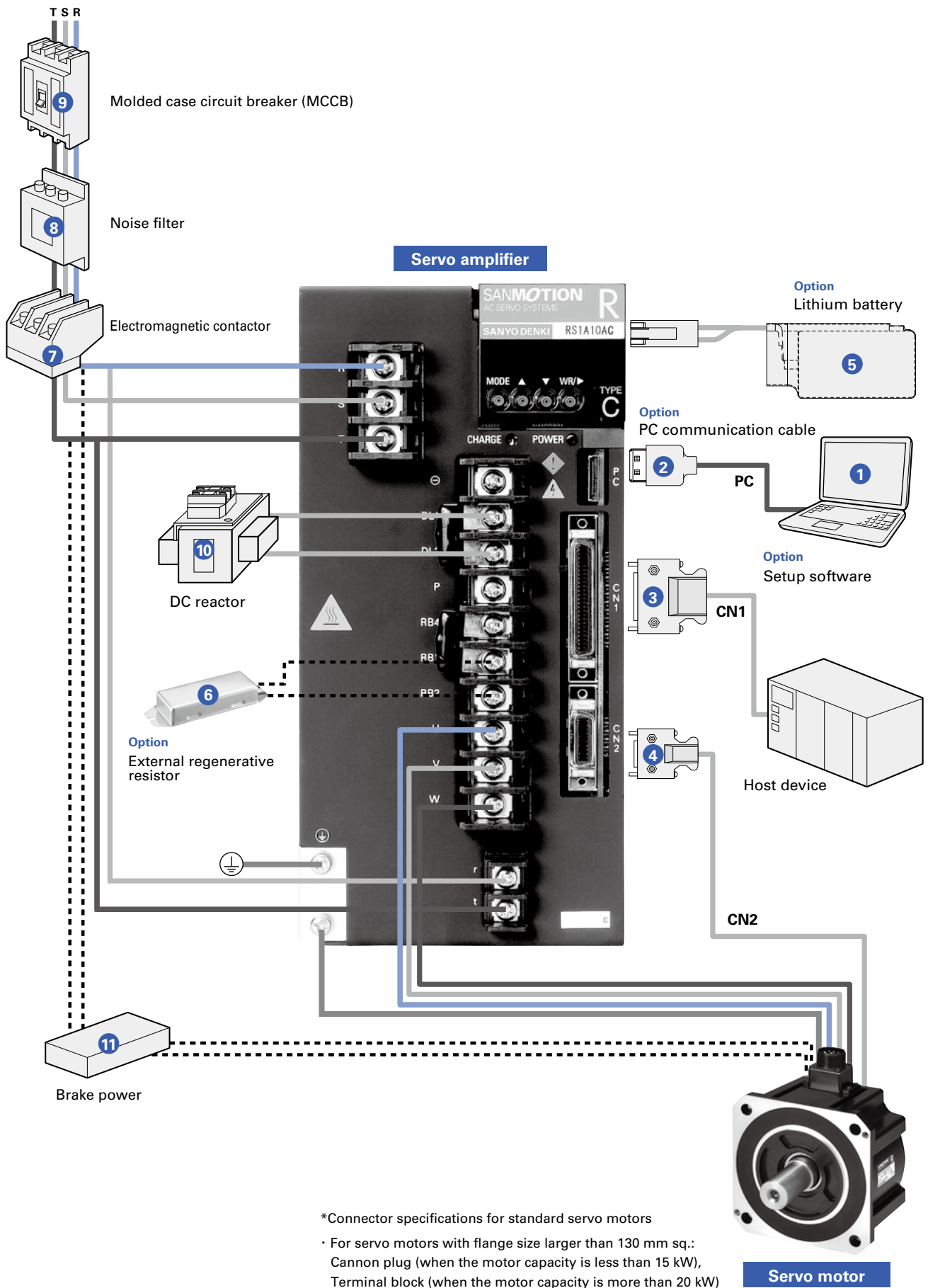

*Connector specifications for standard servo motors

- For servo motors with flange size larger than 130 mm sq.:
 Cannon plug (when the motor capacity is less than 15 kW),
 Terminal block (when the motor capacity is more than 20 kW)

Options and Peripherals (100 to 300 A)

No.	Name	Model no.	Description	Page
1	Setup software	Can be downloaded from Product Information on our website.	Parameters can be set and monitored via communication with a PC.	p. 120
2	PC communication cable	AL-00490833-01	PC communication cable for setup software	p. 131
3	CN1 connector	AL-00385594	To connect to host device	p. 127
4	CN2 connector	AL-00385596	To connect to encoders	p. 127
5	Lithium battery	AL-00494635-01	Used when using a battery-backup method absolute encoder	p. 132
6	External regenerative resistor	REGIST-□...□W□...B, REGIST-500CW□□B	Used for special operations, such as high frequency applications that require greater power dissipation than that provided by the servo amplifier's built-in regenerative resistor	p. 133
7	Electromagnetic contactor	To be provided by the customer	Used to switch the power on and off.	—
8	Noise filter	To be provided by the customer	Used to prevent external noise from the power source line.	—
9	Molded case circuit breaker (MCCB)	To be provided by the customer	Used to protect the power line.	—
10	DC reactor	To be provided by the customer	Used to remove power line harmonics	—
11	Brake power	To be provided by the customer	Used for servo motors with brake	—

Connector sets are also available with set model numbers. See respective pages.

General Specifications

Control function	Position control	
Control system	IGBT: PWM control, sinusoidal drive	
Main Circuit Power Supply *1	3-Phase: 200 to 230 VAC +10, -15%, 50/60 Hz±3 Hz Single-phase: 200 to 230 VAC +10, -15%, 50/60 Hz±3 Hz *2 Single-phase: 100 to 115 VAC +10, -15%, 50/60 Hz±3 Hz *3	
Control circuit power supply *1	Single-phase: 200 to 230 VAC +10, -15%, 50/60 Hz±3 Hz Single-phase: 100 to 115 VAC +10, -15%, 50/60 Hz±3 Hz *3	
Interface Power Supply	24 VDC±10%	
Environment	Ambient temperature	0 to +55°C
	Storage temperature	-20 to +65°C
	Operation and Storage humidity	Below 90%RH (non-condensing)
	Operation altitude	Below 1000 m
	Vibration resistance	0.5 G freq. range 10 to 55 Hz tested for 2 hours in each X, Y and Z-axis directions
	Impact resistance	2 G
Structure	Built-in tray type power supply	

*1
Power source voltage should be within the specified range below.
[200 VAC power input type]:
Specified power supply range = 170 to 253 VAC
[100 VAC power input type]:
Specified power supply range = 85 to 127 VAC

*2
The 200 VAC single-phase input type is compatible only with 15, 30, and 50 A. Please set parameters before using single-phase input.

*3
The 100 VAC single-phase input type is compatible only with 15 and 30 A. Please set parameters before using single-phase input.



Performance

Speed control range	1:5000
Frequency characteristics	600 Hz (JL=JM)
Permissible load moment of inertia	10 times the motor rotary inertia

Built-in functions

Protection functions	Overcurrent, Current detection error, Overload, Regeneration error, Amplifier overheating, External overheating, Overvoltage, Main circuit power supply undervoltage, Main power supply open phase, Control circuit power supply error, Encoder error, Overspeed, Speed control error, Speed feedback error, Excessive position deviation, Position command pulse error, CPU error, Built-in memory error, Battery error, Parameter error
Digital operator	Status display, Monitor display, Alarm display, Parameter setting, Adjustment mode
Dynamic brake circuit	Built in/None selectable
Regenerative resistor	15 to 150A: Built in/None selectable, 300 A: None *For all models from 15 to 300 A, optional external resistors can be equipped.
Monitor	Speed monitor (VMON) 2.0 V±10% (at 1000 min ⁻¹), Torque (thrust force) command monitor (TCMON) 2.0 V±10% (at 100%)

Safety standards

Safety standards	North American safety standards (UL ratings)	UL508C
	European directive	EN50178, EN61000-6-2, EN61800-3

RS-485 communication specifications

Item	Item	Default value	Remarks
Protocol	Modbus-RTU	—	Fixed to binary mode (ASCII mode is not supported)
Interface	RS-485 (1: N)	—	N = 8*
Transmission speed (bps)	4800, 9600, 19200, 38400, 57600, 115200	115200	Set up with setup software or rotary switch on the front surface of the amplifier.
Start bit	1	1	Fixed
Data length (bit)	8	8	Fixed
Parity	None, even number, odd number	Even number	Set up with setup software.
Stop bit	1, 2	1	
Electrical Specifications	RS-485 compliant (half duplex communication)	RS-485 compliant (half duplex communication)	Fixed
Connector	RJ-45	—	

* This servo amplifier can be connected to up to 8 axes per segment. When connecting 8 axes or more, contact us for details.

Dimensions [Unit: mm]

15 A
Mass: 0.9 kg

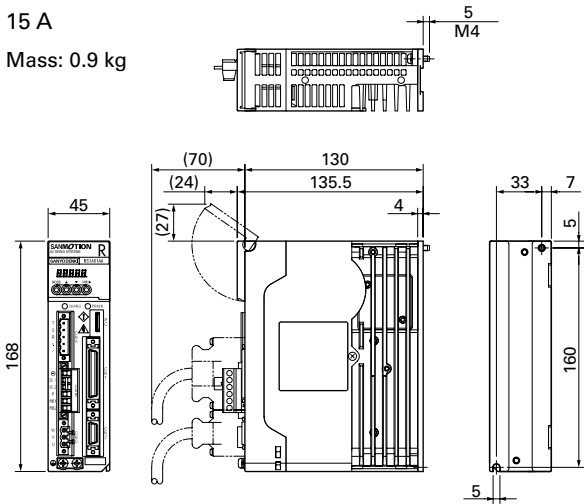

30 A
Mass: 1.0 kg

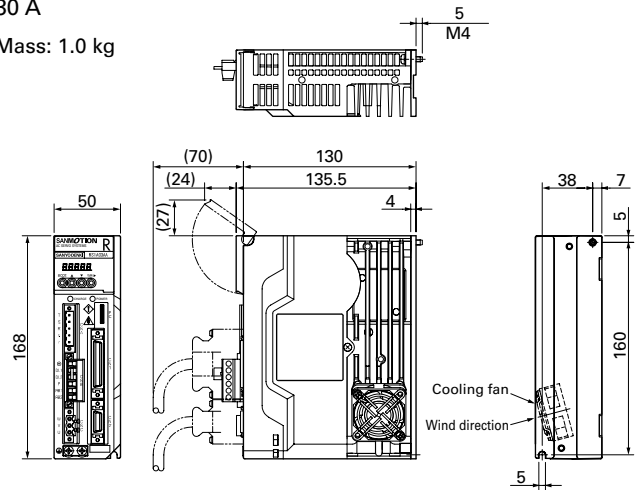

50 A
Mass: 2.2 kg

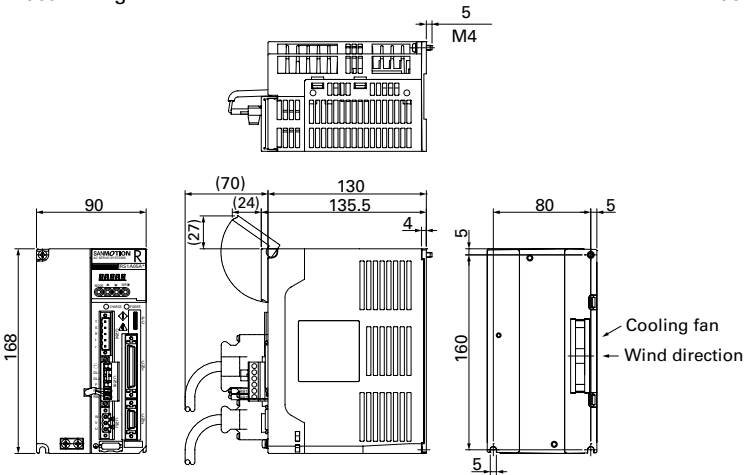

100 A
Mass: 5.2 kg

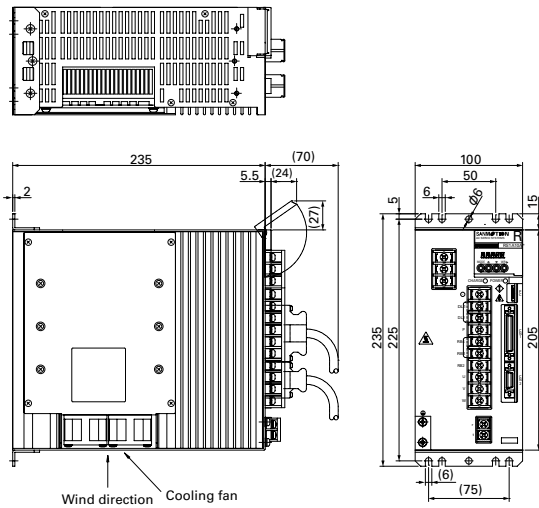

150 A
Mass: 6.5 kg

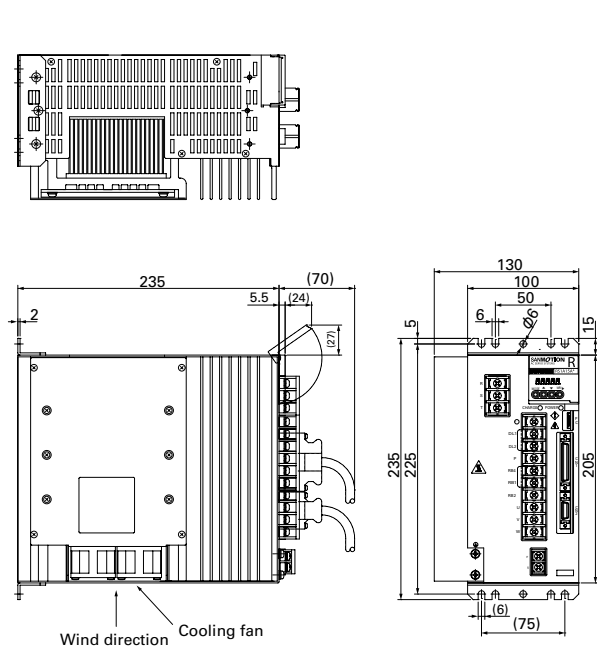

300 A
Mass: 9.8 kg

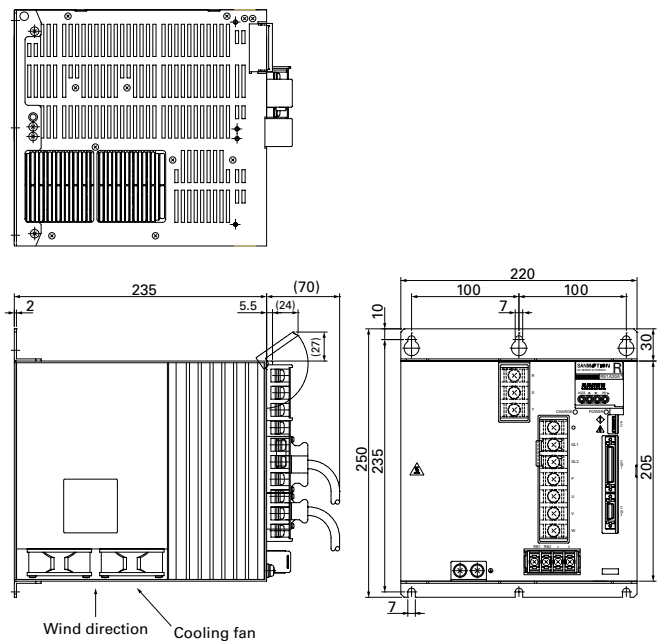

External Wiring Diagram

DIO type

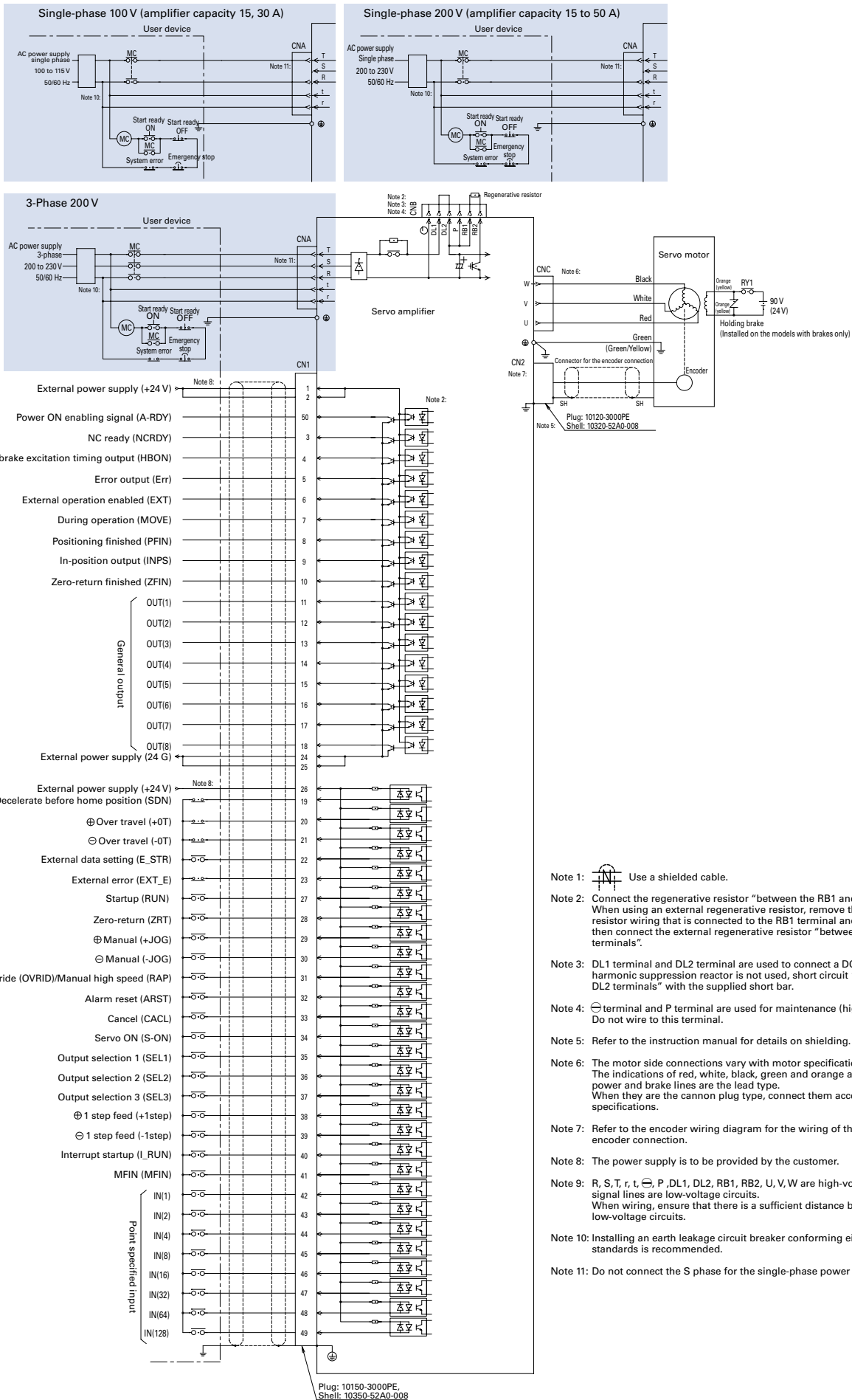

External Wiring Diagram

RS-485 communication type

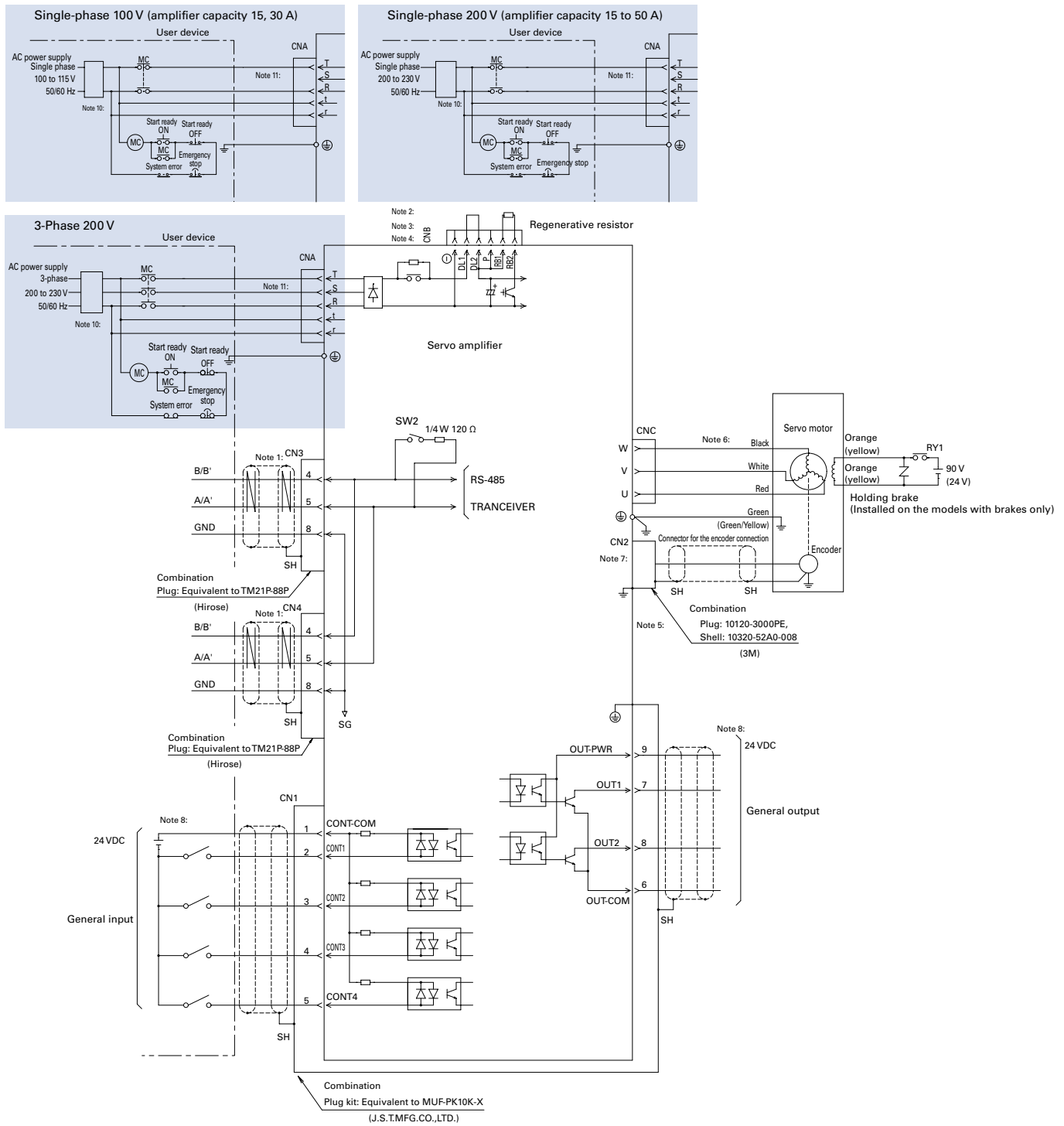

External Wiring Diagram

Serial Encoder

Optical absolute encoder for incremental systems [Model No. PA035S]

Option: Optical battery-backup method absolute encoder [Model No. PA035C]

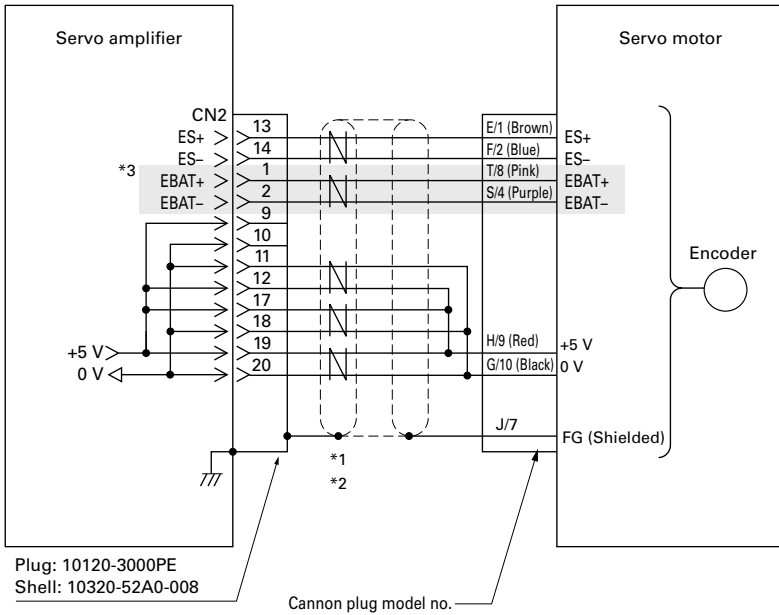

Plug: 10120-3000PE
Shell: 10320-52A0-008

Cannon plug model no.

Flange size: 130 mm sq. or larger	JN2DS10SL1-R	JN2FS10SL1-R
	JN2DS10SL2-R	JN2FS10SL2-R
	JN2DS10SL3-R	JN2FS10SL3-R

- *1 Use a shielded twisted pair cable.
- *2 Maximum cable lengths by conductor size of the power supply cable (5 V, SG) are shown in the table below.

Conductor size		Conductor resistance (Ω/km) *20°C	Length (m)
AWG	SQ (mm ²)		
26	0.15	150 or less	5
24	0.2	100 or less	10
22	0.3	60 or less	15
20	0.5	40 or less	25
18	0.75	25 or less	40

*Conductor resistance differs by conductor specifications.

- *3 Battery lines (EBAT+, EBAT-) are necessary only when a battery-backup method absolute encoder is used.
- *4 Lead wire colors are indicated in parentheses. For lead wire colors and cannon plug pin numbers, see the following table.

	ES+	ES-	EBAT+	EBAT-	+5V	0V	FG
100 mm sq. or smaller	Brown	Blue	Pink*3	Purple*3	Red	Black	Shielded
130 mm sq. or larger	1	2	8*3	4*3	9	10	7

Option: Pulse Encoder

Wire-saving incremental encoder

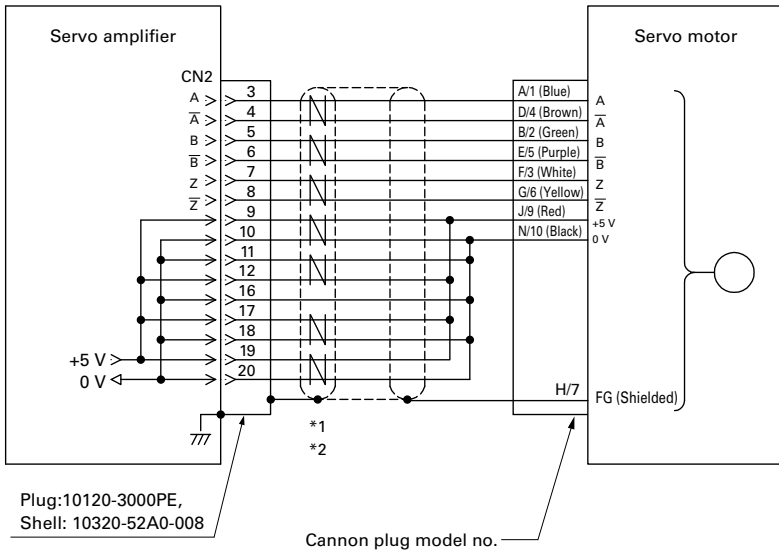

Plug: 10120-3000PE,
Shell: 10320-52A0-008

Cannon plug model no.

Flange size: 130 mm sq. or larger	JN2DS10SL1-R	JN2FS10SL1-R
	JN2DS10SL2-R	JN2FS10SL2-R
	JN2DS10SL3-R	JN2FS10SL3-R

- *1 Use a shielded twisted pair cable.
- *2 Maximum cable lengths by conductor size of the power supply cable (5 V, SG) are shown in the table below.

Conductor size		Conductor resistance (Ω/km) *20°C	Length (m)
AWG	SQ (mm ²)		
26	0.15	150 or less	5
24	0.2	100 or less	10
22	0.3	60 or less	15
20	0.5	40 or less	25
18	0.75	25 or less	40

*Conductor resistance differs by conductor specifications.

- *3 Lead wire colors are indicated in parentheses. For lead wire colors and cannon plug pin numbers, see the following table:

	A	Ā	B	B̄	Z	Z̄	+5V
100 mm sq. or smaller	Blue	Brown	Green	Purple	White	Yellow	Red
130 mm sq. or larger	1	4	2	5	3	6	9

	0V	FG
100 mm sq. or smaller	Black	Shielded
130 mm sq. or larger	10	7

Servo Amplifiers

R Multi-axis Pulse Input type

Servo Amplifier Capacity: Amplifier unit 15 A (up to 6 axes) / 30 A (up to 4 axes)

Multi-axis controllable servo amplifier (up to 6 axes). Multiple axes can be powered and commanded from only one unit, enabling wire saving and space saving.



How to read model numbers

Note that not all the possible combinations of the numbers and characters below are valid. Also, some of the numbers/characters listed below are for optional models. For model numbers valid as standard products, refer to "Standard Model Number List".

Amplifier unit

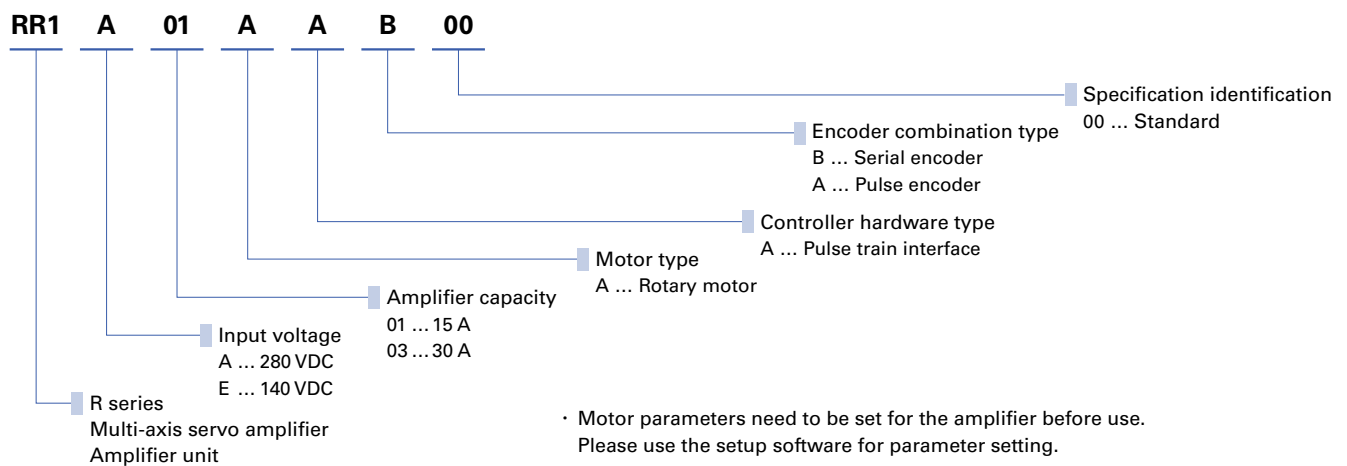

Power supply unit

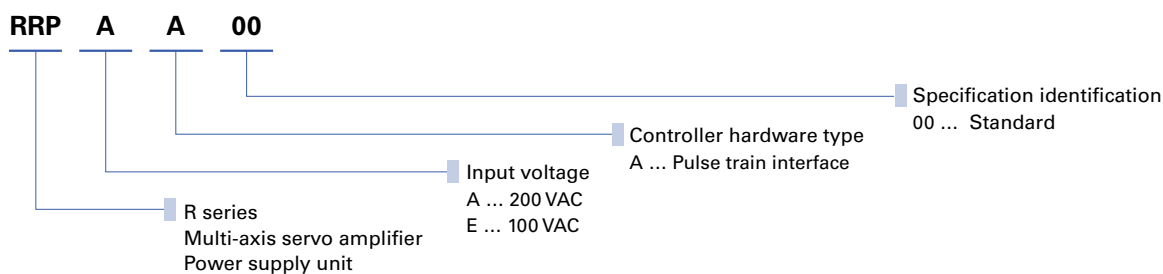

Motherboard

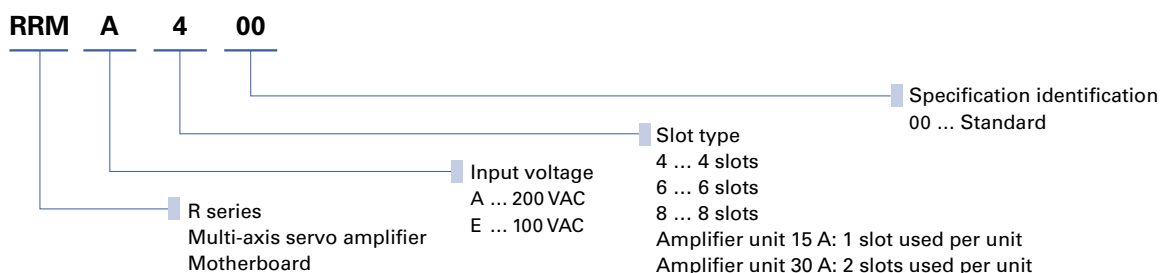

Required number of amplifier units, a power supply unit, and a motherboard are used as a set. The maximum amplifier capacity is 800 W for 100 VAC input, and 2000 W for 200 VAC input.

System Configuration

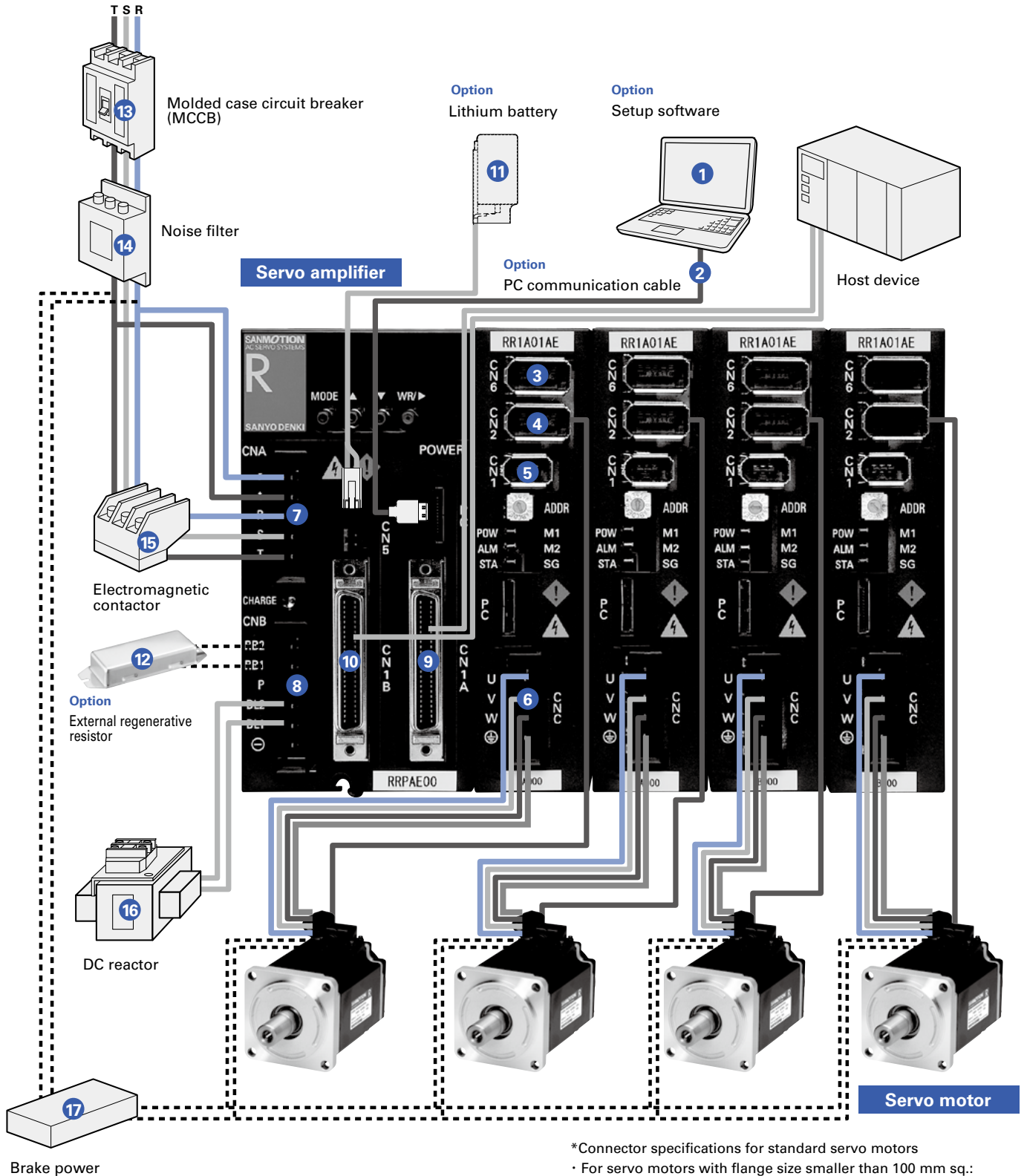

*Connector specifications for standard servo motors

- For servo motors with flange size smaller than 100 mm sq.: Cable without connector. (when servo motors are smaller than 80 mm sq., a cable with a connector is available as an option. Refer to p. 138)
- For servo motors with flange size larger than 130 mm sq.: Cannon plug (when the motor capacity is less than 15 kW), Terminal block (when the motor capacity is more than 20 kW)

Options and Peripherals

No.	Name	Model no.	Description	Page
1	Setup software	Can be downloaded from Product Information on our website.	Parameters can be set and monitored via communication with a PC.	p. 120
2	PC communication cable	AL-00490833-01	PC communication cable for setup software	p. 131
3	CN6 connector	AL-00632607	For encoder divided signal output	p. 128
4	CN2 connector	AL-00632607	For encoder signal	p. 128
5	CN1 connector	AL-Y0003305-01	General I/O connector	p. 128
6	CNC connector	AL-00632604	To connect to servo motor	p. 128
7	CNA connector	AL-00632600	Control/main circuit power input connector	p. 128
8	CNB connector	AL-00632602	To connect external regenerative resistor and DC reactor	p. 128
9	CN1A connector	AL-00385594	To connect to host device	p. 128
10	CN1B connector	AL-00385594	To connect to host device	p. 128
11	Lithium battery	AL-00494635-01	Used when using a battery-backup method absolute encoder	p. 132
12	External regenerative resistor	REGIST-□□□□□W□□□□B, REGIST-500CW□□□□B	Used for special operations, such as high frequency applications that require greater power dissipation than that provided by the servo amplifier's built-in regenerative resistor	p. 133
13	Molded case circuit breaker (MCCB)	To be provided by the customer	Used to protect the power line.	—
14	Noise filter	To be provided by the customer	Used to prevent external noise from the power source line.	—
15	Electromagnetic contactor	To be provided by the customer	Used to switch the power on and off.	—
16	DC reactor	To be provided by the customer	Used to remove power line harmonics	—
17	Brake power	To be provided by the customer	Used for servo motors with brake	—

Connector sets are also available with set model numbers. See respective pages.

General Specifications

Control function (amplifier unit)	Position control	
Control system (amplifier unit)	IGBT: PWM control, sinusoidal drive	
Main Circuit Power Supply *1 (power supply unit)	3-Phase: 200 to 230 VAC +10, -15%, 50/60 Hz±3% Single-phase: 100 to 115 VAC +10, -15%, 50/60 Hz±3%	
Control circuit power supply *1 (power supply unit)	Single-phase: 200 to 230 VAC +10, -15%, 50/60 Hz±3% Single-phase: 100 to 115 VAC +10, -15%, 50/60 Hz±3%	
Environment	Ambient temperature	0 to 40°C (under natural air cooling), 0 to 55°C (under forced air cooling)
	Storage temperature	-20 to +65°C
	Operation and Storage humidity	Below 90%RH (non-condensing)
	Operation altitude	Below 1000 m
	Vibration resistance	0.5 G freq. range 10 to 55 Hz tested for 2 hours in each X, Y and Z-axis directions
	Impact resistance	2 G
Structure	Rack-mount type	

*1:
Power supply voltage should be within the specified range.



■ Performance

Speed control range	1:5000
Frequency characteristics	600 Hz (JL=JM)
Permissible load moment of inertia	10 times the motor rotary inertia

■ Built-in functions

Protection functions	Overcurrent, Current detection error, Overload, Overvoltage, Encoder error, Overspeed, Speed control error, Speed feedback error, CPU error, Built-in memory error, Parameter error, etc.
Digital operator	Status display, Monitor display, Alarm display, Parameter setting, Adjustment mode
Dynamic brake circuit	Built in/None selectable
Regenerative resistor	Built into the power supply unit (not into the amplifier unit) *For all models, optional external resistors can be equipped.
Monitor	Speed monitor (VMON) 2.0 V±10% (at 1000 min ⁻¹), Torque (thrust force) command monitor (TCMON) 2.0 V±10% (at 100%)

■ Safety standards

Safety standards	North American safety standards (UL ratings)	UL508C
	European directive	EN50178, EN61000-6-2, EN61800-3

The maximum amplifier capacity is 800 W for 100 VAC input, and 2000 W for 200 VAC input.

Dimensions [Unit: mm]

Amplifier unit

15 A

Mass: 0.48 kg

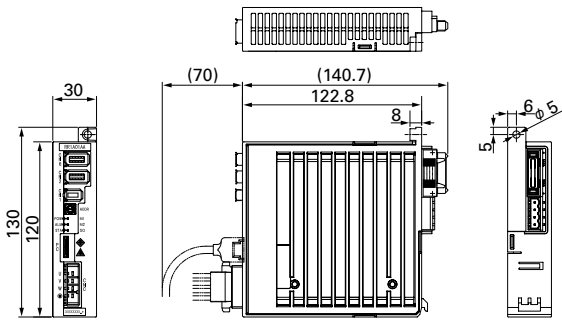

30 A

Mass: 0.77 kg

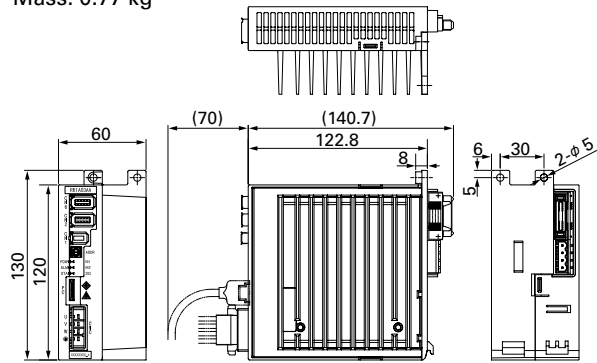

Power supply unit

Mass: 0.55 kg

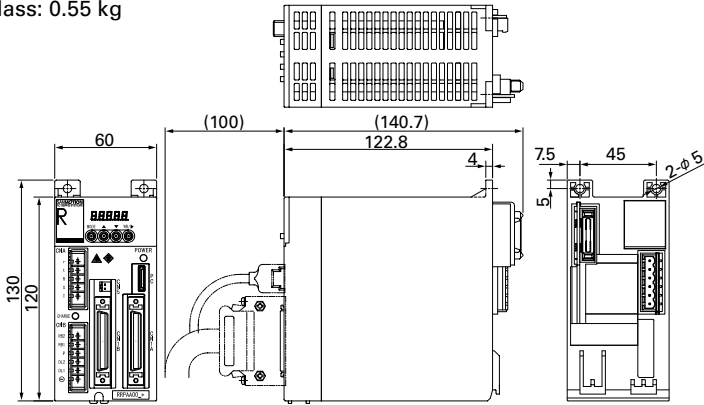

Motherboard

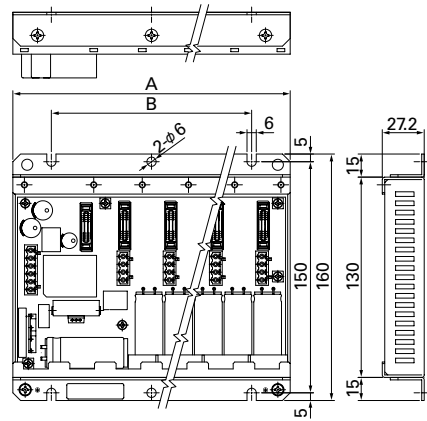

Model no.	Number of slots	Dimensions		Mass
		A	B	
RRMA400 RRME400	4	180	130	0.99
RRMA600 RRME600	6	240	190	1.33
RRMA800 RRME800	8	300	250	1.57

Combination example of Amplifier unit + Power supply unit + Motherboard

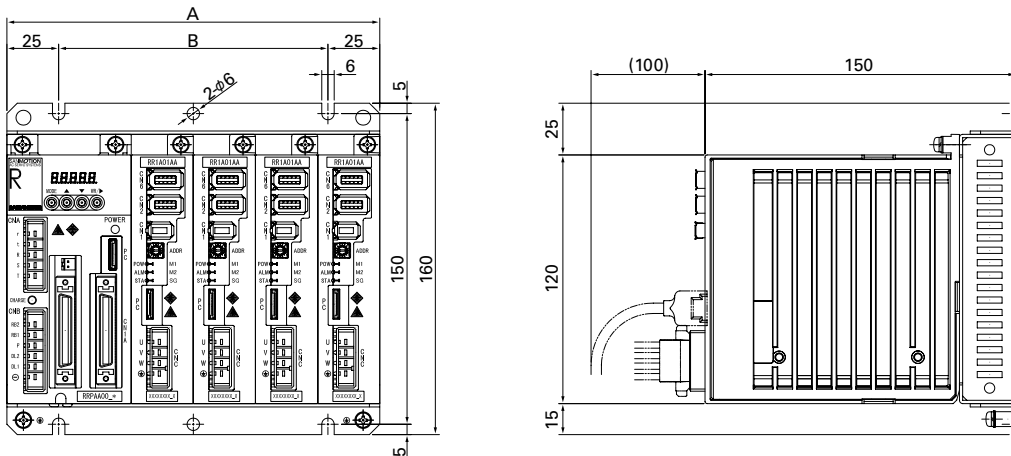

Number of slots	Dimensions	
	A	B
4	180	130
6	240	190
8	300	250

External Wiring Diagram

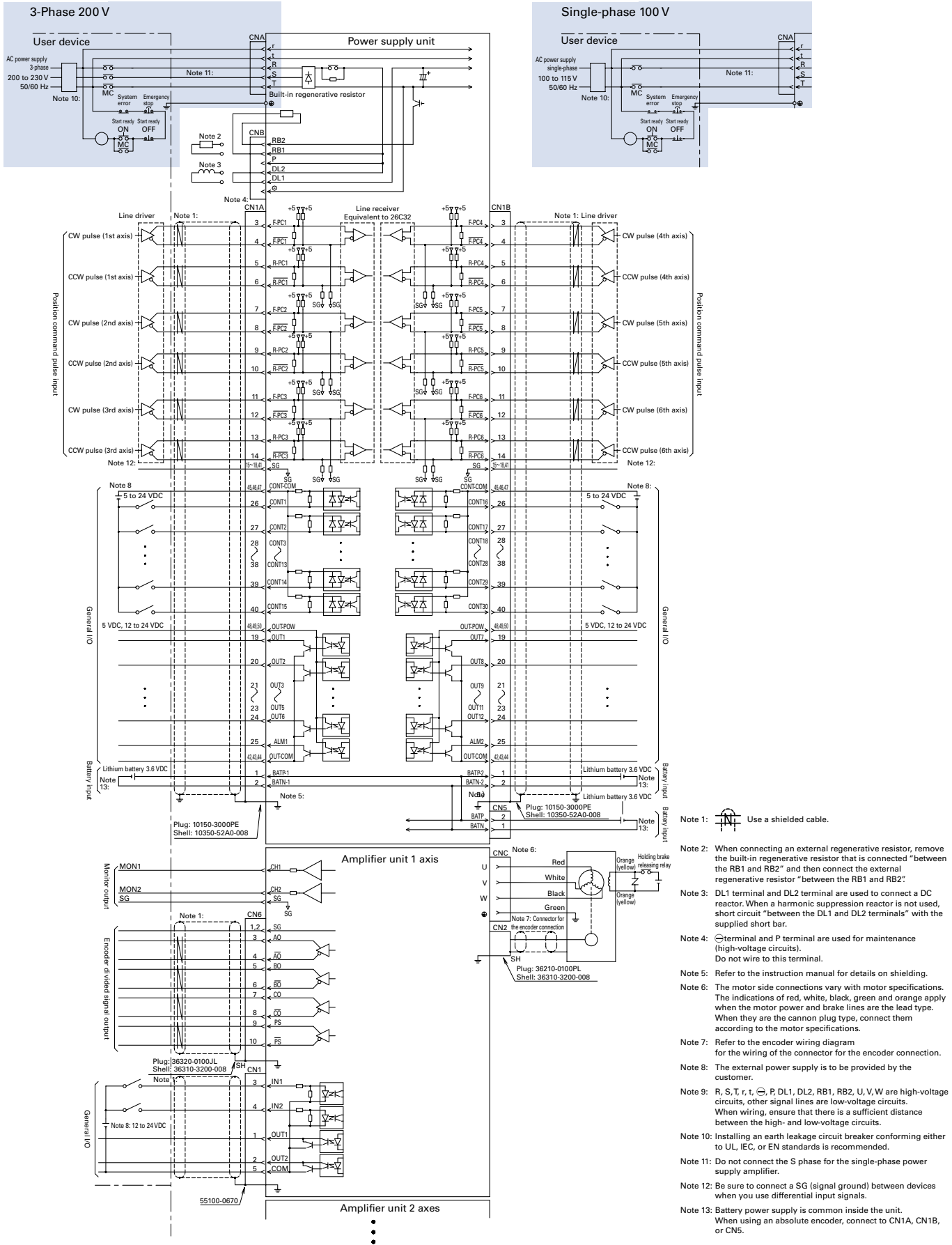

External Wiring Diagram

Serial Encoder

Optical absolute encoder for incremental systems [Model No. PA035S]

Option: Optical battery-backup method absolute encoder [Model No. PA035C]

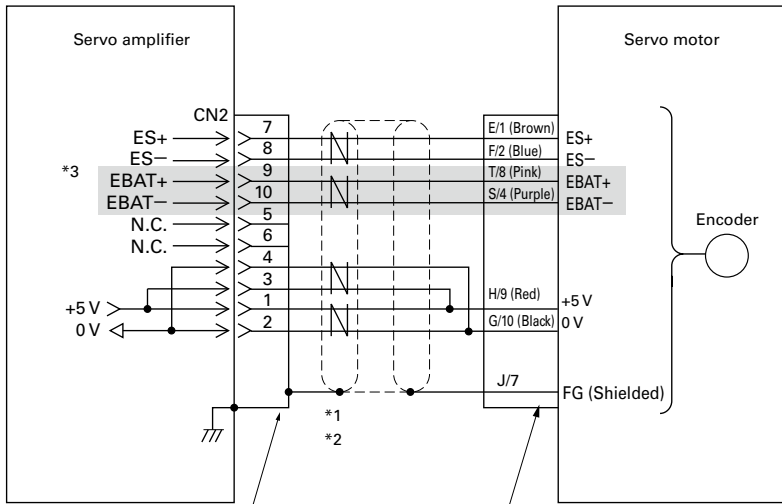

Plug: 36210-0100PL
Shell: 36310-3200-008

Cannon plug model no.

Flange size: 130 mm sq. or larger	JN2DS10SL1-R	JN2FS10SL1-R
	JN2DS10SL2-R	JN2FS10SL2-R
	JN2DS10SL3-R	JN2FS10SL3-R

- *1 Use a shielded twisted pair cable.
- *2 Maximum cable lengths by conductor size of the power supply cable (5 V, SG) are shown in the table below.

Conductor size		Conductor resistance (Ω/km) *at 20°C	Length (m)
AWG	SQ (mm ²)		
26	0.15	150 or less	5
24	0.2	100 or less	10
22	0.3	60 or less	15
20	0.5	40 or less	25
18	0.75	25 or less	40

*Conductor resistance differs by conductor specifications.

- *3 Battery lines (EBAT+, EBAT-) are necessary only when a battery-backup method absolute encoder is used.
- *4 Lead wire colors are indicated in parentheses. For lead wire colors and cannon plug pin numbers, see the following table.

	ES+	ES-	EBAT+	EBAT-	+5V	0V	FG
100 mm sq. or smaller	Brown	Blue	Pink*3	Purple*3	Red	Black	Shielded
130 mm sq. or larger	1	2	8*3	4*3	9	10	7

Option: Pulse Encoder

Wire-saving incremental encoder

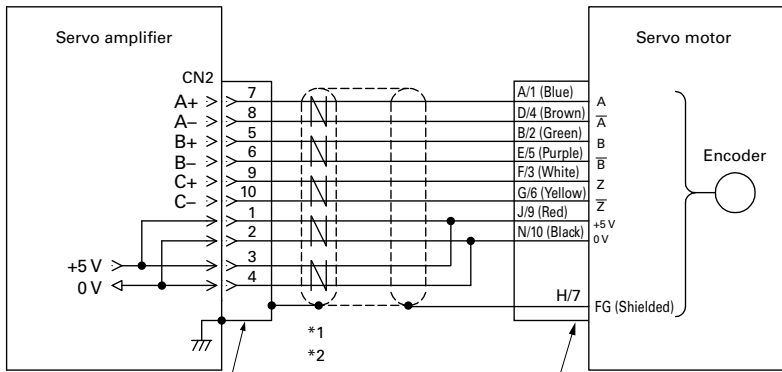

Plug: 36210-0100PL
Shell: 36310-3200-008

Cannon plug model no.

Flange size: 130 mm sq. or larger	JN2DS10SL1-R	JN2FS10SL1-R
	JN2DS10SL2-R	JN2FS10SL2-R
	JN2DS10SL3-R	JN2FS10SL3-R

- *1 Use a shielded twisted pair cable.
- *2 Maximum cable lengths by conductor size of the power supply cable (5 V, SG) are shown in the table below.

Conductor size		Conductor resistance (Ω/km) *at 20°C	Length (m)
AWG	SQ (mm ²)		
26	0.15	150 or less	5
24	0.2	100 or less	10
22	0.3	60 or less	15
20	0.5	40 or less	25
18	0.75	25 or less	40

*Conductor resistance differs by conductor specifications.

- *3 Lead wire colors are indicated in parentheses. For lead wire colors and cannon plug pin numbers, see the following table:

	A	A-bar	B	B-bar	Z	Z-bar	+5V
100 mm sq. or smaller	Blue	Brown	Green	Purple	White	Yellow	Red
130 mm sq. or larger	1	4	2	5	3	6	9
	0V	FG					
100 mm sq. or smaller	Black	Shielded					
130 mm sq. or larger	10	7					

Servo Motors

R2•R1•R5 Rotary Motor

Output capacity: 30 W to 30 kW

Rotary servo motors with a wide range of products.



How to read model numbers

Note that not all the possible combinations of the numbers and characters below are valid. Also, some of the numbers/characters listed below are for optional models. For model numbers valid as standard products, refer to "Standard Model Number List".

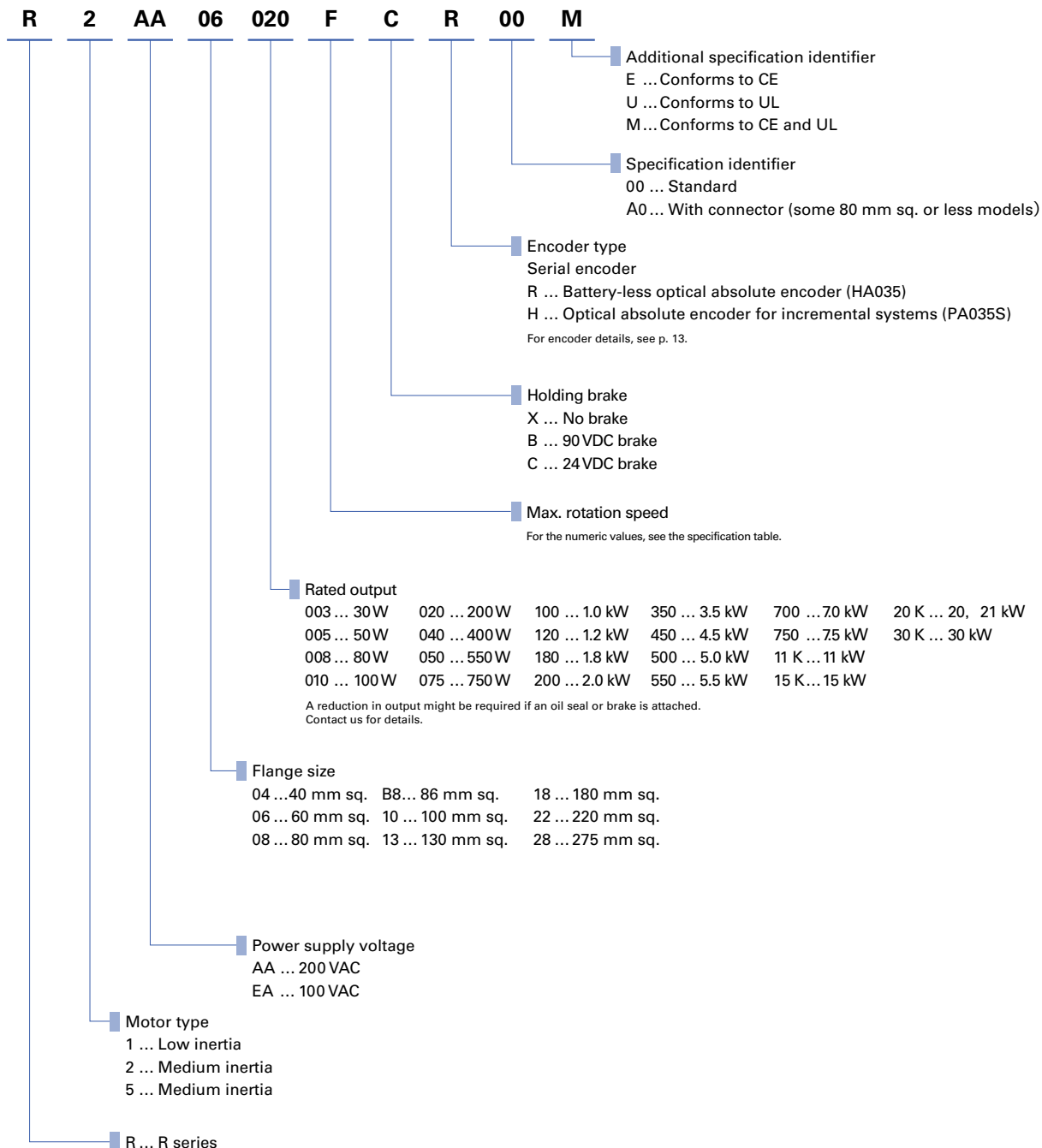

Specifications

R2 Servo Motors High Efficiency and Low Ripple (Medium Inertia) RoHS

Input voltage **100 VAC**

Servo Amplifier Model No.				R 3E Model	RS3E01□□〈10 A〉	RS3E02□□〈20 A〉	
				R ADVANCED	RS2E01□□〈15 A〉		
				R	RS1E01□□/RR1E01AAB〈15 A〉		
Servo Motor Model No. 〈 〉 indicates flange size				R2EA04003F 〈40 mm sq.〉	R2EA04005F 〈40 mm sq.〉	R2EA04008F 〈40 mm sq.〉	
	Status	Symbol	Unit				
Rated Output	★	PR	kW	0.03	0.05*4	0.08	
Rated Speed	★	NR	min ⁻¹	3000	3000	3000	
Maximum Speed	★	N _{max}	min ⁻¹	6000	6000	6000	
Rated Torque	★	TR	N·m	0.098	0.159*4	0.255	
Continuous Stall Torque	★	TS	N·m	0.108	0.167	0.255	
Peak Stall Torque	★	TP	N·m	0.37	0.59	0.86	
Rated Armature Current	★	IR	Arms	0.94	1.2	1.3	
Armature Stall Current	★	IS	Arms	1.0	1.3	1.3	
Peak Armature Stall Current	★	IP	Arms	3.7	4.9	4.5	
Torque Constant	☆	KT	N·m/Arms	0.116	0.142	0.22	
Voltage Constant for each Phase	☆	KEφ	mV/min ⁻¹	4.04	4.97	7.7	
Phase Resistance	☆	Rφ	Ω	4.0	3.0	2.9	
Rated Power Rate	★	QR	kW/s	3.9	6.7*4	10	
Electrical Time Constant	☆	te	ms	0.55	0.67	0.81	
Mechanical Time Constant (Not including Encoder)	☆	tm	ms	2.2	1.7	0.98	
Rotor Inertia		JM	×10 ⁻⁴ kg·m ² (GD ² /4)	0.0247	0.0376	0.0627	
Absolute Encoder Inertia		JS	×10 ⁻⁴ kg·m ² (GD ² /4)		0.0042*1		
Servo Motor Mass *1		We	kg	0.37	0.41	0.53	
Brake Static Friction Torque		Tb	N·m	0.32 min.			
Brake Rated Voltage		Vb	V	90 VDC/24 VDC±10%			
Brake Rated Current		Ib	A	0.07/0.27			
Rotor Moment of Inertia (Brake)		Jb	×10 ⁻⁴ kg·m ² (GD ² /4)	0.0078			
Brake Mass		W	kg	0.27	0.27	0.27	
Servo amplifier power supply capacity (rating)			kVA	0.2	0.2	0.4	
CE and UL approved servo motors *5				Yes			
Servo motor protection code				IP67, IP65			
Size of aluminum plates for heat radiation during measurement				250 × 250 × 6 mm			
Page for motor dimensions				p. 112			

*1 Values are for motors with encoder [HA035].
For motor mass with the following encoders, contact us for details.
· Battery-backup method absolute encoder
· Wire-saving incremental encoder

*2 Items with ★ and speed - torque characteristics indicate values after temperature rise saturation when used with a standard servo amplifier. The values are the typical values.

*3 ☆ : Indicates a typical value when the winding temperature is 20°C. The values are the typical values.

*4 With the optional oil seals, rated outputs of servo motors might be reduced to 80 to 95% of the values in the above table.

*5 Our standard servo amplifiers are CE and UL approved.

Speed-Torque Characteristics

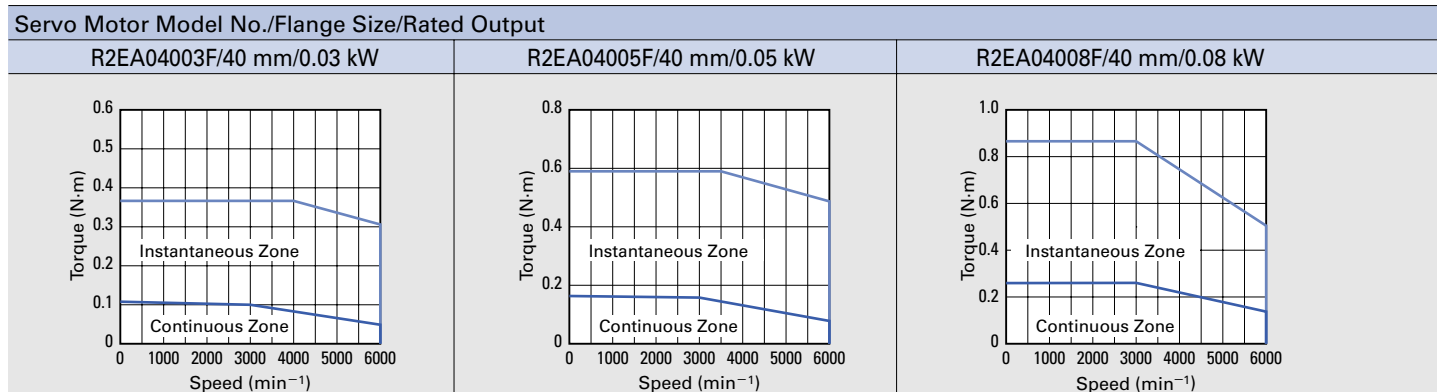

These values are for when the input voltage is a 100 VAC circuit. The area of the instantaneous zone decreases when the power supply voltage is less than 100 VAC.

RS3E02□□〈20 A〉	RS3E03□□〈30 A〉	R 3E Model	Servo Amplifier Model No.		
RS2E01□□〈15 A〉	RS2E03□□〈30 A〉	R ADVANCED			
RS1E01□□/RR1E01AAB〈15 A〉	RS1E03□□/RR1E03AAB〈30 A〉	R			
R2EA06010F 〈60 mm sq.〉	R2EA06020F 〈60 mm sq.〉	Servo Motor Model No. 〈 〉 indicates flange size			
		Unit	Symbol	Status	
0.1	0.2	kW	PR	★	Rated Output
3000	3000	min ⁻¹	NR	★	Rated Speed
6000	6000	min ⁻¹	N _{max}	★	Maximum Speed
0.318	0.637	N·m	TR	★	Rated Torque
0.318	0.686	N·m	TS	★	Continuous Stall Torque
1.0	2.2	N·m	TP	★	Peak Stall Torque
1.7	3.1	Arms	IR	★	Rated Armature Current
1.7	3.2	Arms	IS	★	Armature Stall Current
5.6	11.9	Arms	IP	★	Peak Armature Stall Current
0.206	0.224	N·m/Arms	KT	☆	Torque Constant
7.2	7.82	mV/min ⁻¹	KEφ	☆	Voltage Constant for each Phase
1.5	0.6	Ω	Rφ	☆	Phase Resistance
8.6	19	kW/s	QR	★	Rated Power Rate
1.9	2.6	ms	te	☆	Electrical Time Constant
1.2	0.79	ms	tm	☆	Mechanical Time Constant (Not including Encoder)
0.117	0.219	X10 ⁻⁴ kg·m ² (GD ² /4)	JM		Rotor Inertia
0.0042*1		X10 ⁻⁴ kg·m ² (GD ² /4)	JS		Absolute Encoder Inertia
0.74	0.99	kg	We		Servo Motor Mass *1
0.36 min.	1.37 min.	N·m	Tb		Brake Static Friction Torque
90 VDC/24 VDC±10%		V	Vb		Brake Rated Voltage
0.07/0.27	0.11/0.32	A	Ib		Brake Rated Current
0.06		X10 ⁻⁴ kg·m ² (GD ² /4)	Jb		Rotor Moment of Inertia (Brake)
0.34	0.39	kg	W		Brake Mass
0.5	0.6	kVA			Servo amplifier power supply capacity (rating)
Yes					CE and UL approved servo motors *5
IP67, IP65					Servo motor protection code
250 × 250 × 6 mm					Size of aluminum plates for heat radiation during measurement
p. 112					Page for motor dimensions

Servo Motor Operating Ambient Conditions

Operating temperature and humidity	Temp.: 0 to 40°C. Humidity: 90% max. (non-condensing)
Vibration resistance	24.5 m/s ²
Shock resistance	98 m/s ² , twice
Operation altitude	1000 m or lower above sea level
Installation location	Indoor (without direct sunlight) Location where no substance that gives adverse effects on the device and motor, such as corrosive gas, flammable gas, or dust exists

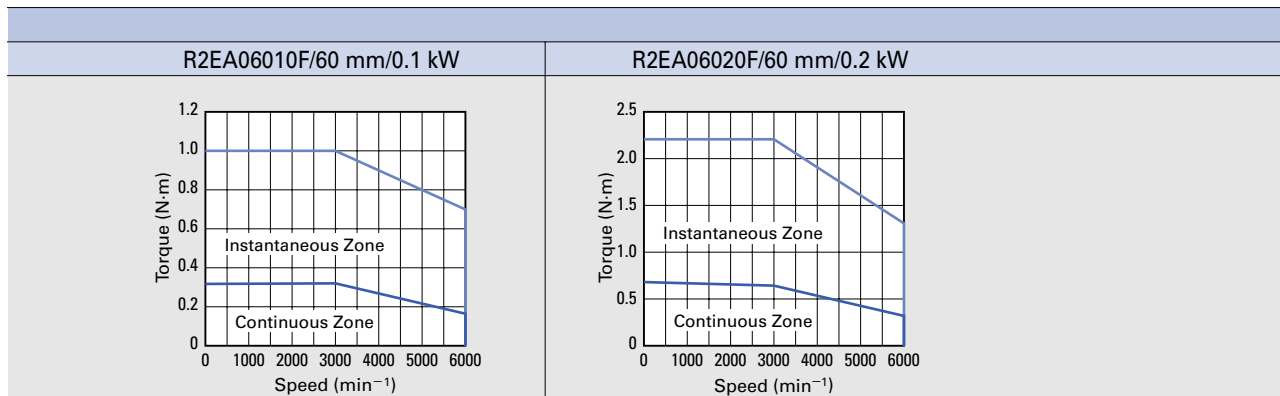

Specifications

R2 Servo Motors High Efficiency and Low Ripple (Medium Inertia) RoHS

Input voltage **200 VAC**

Servo Amplifier Model No.				R 3E Model				
				RS3A01□□《10 A》				
				R ADVANCED				
RS2A01□□《15 A》				R				
RS1A01□□/RR1A01AAB00《15 A》				Servo Motor Model No. 《》indicates flange size				
Servo Motor Model No.		Status	Symbol	Unit	R2AA04003F 《40 mm sq.》	R2AA04005F 《40 mm sq.》	R2AA04010F 《40 mm sq.》	R2AA06010F 《60 mm sq.》
Rated Output	★	PR	kW	0.03	0.05*4	0.1 (0.09) *4	0.1	
Rated Speed	★	NR	min ⁻¹	3000	3000	3000	3000	
Maximum Speed	★	N _{max}	min ⁻¹	6000	6000	6000	6000	
Rated Torque	★	T _R	N·m	0.098	0.159*4	0.318 (0.286) *4	0.318	
Continuous Stall Torque	★	T _S	N·m	0.108	0.167	0.318	0.353	
Peak Stall Torque	★	T _P	N·m	0.37	0.59	1.18	1.13	
Rated Armature Current	★	I _R	Arms	0.51	0.67	0.81	0.86	
Armature Stall Current	★	I _S	Arms	0.56	0.69	0.81	0.86	
Peak Armature Stall Current	★	I _P	Arms	2.15	2.8	3.3	3.5	
Torque Constant	☆	K _T	N·m/Arms	0.201	0.246	0.424	0.375	
Voltage Constant for each Phase	☆	K _{Eφ}	mV/min ⁻¹	7.0	8.6	14.8	13.1	
Phase Resistance	☆	R _φ	Ω	12	9	9.3	4.8	
Rated Power Rate	★	Q _R	kW/s	3.9	6.7*4	16 (13) *4	8.6	
Electrical Time Constant	☆	t _e	ms	0.55	0.67	0.82	2	
Mechanical Time Constant (Not including Encoder)	☆	t _m	ms	2.2	1.7	0.97	1.2	
Rotor Inertia		J _M	×10 ⁻⁴ kg·m ² (GD ² /4)	0.0247	0.0376	0.0627	0.117	
Absolute Encoder Inertia		J _S	×10 ⁻⁴ kg·m ² (GD ² /4)	0.0042*1				
Servo Motor Mass *1		W _e	kg	0.37	0.41	0.53	0.74	
Brake Static Friction Torque		T _b	N·m	0.32 min.			0.36 min.	
Brake Rated Voltage		V _b	V	90 VDC/24 VDC±10%				
Brake Rated Current		I _b	A	0.07/0.27				
Rotor Moment of Inertia (Brake)		J _b	×10 ⁻⁴ kg·m ² (GD ² /4)	0.0078			0.06	
Brake Mass		W	kg	0.27	0.27	0.27	0.34	
Servo amplifier power supply capacity (rating)			kVA	0.2	0.2	0.3	0.3	
CE and UL approved servo motors *5				Yes				
Servo motor protection code				IP67, IP65				
Size of aluminum plates for heat radiation during measurement				250 × 250 × 6 mm				
Page for motor dimensions				p. 112				

*1 Values are for motors with encoder [HA035].
For motor mass with the following encoders, contact us for details.
· Battery-backup method absolute encoder
· Wire-saving incremental encoder

*2 Items with ★ and speed - torque characteristics indicate values after temperature rise saturation when used with a standard servo amplifier. The values are the typical values.

*3 ☆ : Indicates a typical value when the winding temperature is 20°C . The values are the typical values.

*4 Values in parentheses are the output values for motors with brakes. With the optional oil seals, rated outputs of servo motors might be reduced to 80 to 95% of the values in the above table.

*5 Our standard servo amplifiers are CE and UL approved.

Speed-Torque Characteristics

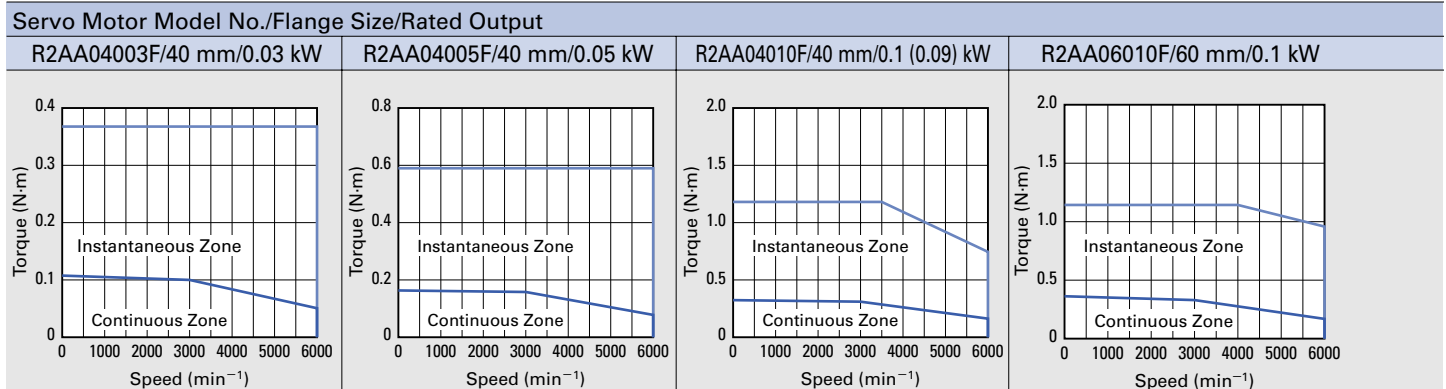

These values are for when the input voltage is a 3-phase 200 VAC circuit. The characteristics of the instantaneous zone may change when the input voltage is less than 200 VAC or single-phase 200 VAC.

RS3A02□□〈20 A〉				R 3E Model	Servo Amplifier Model No.		
RS2A01□□〈15 A〉		RS2A03□□〈30 A〉		R ADVANCED			
RS1A01□□/RR1A01AAB00〈15 A〉		RS1A03□□/ RR1A03AAB00〈30 A〉		R			
R2AA06020F 〈60 mm sq.〉	R2AA06040H 〈60 mm sq.〉	R2AA08020F 〈80 mm sq.〉	R2AA06040F 〈60 mm sq.〉	Servo Motor Model No. 〈 〉 indicates flange size			
				Unit	Symbol	Status	
0.2	0.4 (0.36) *4	0.2	0.4 (0.36) *4	kW	PR	★	Rated Output
3000	3000	3000	3000	min ⁻¹	NR	★	Rated Speed
6000	3000	6000	6000	min ⁻¹	N _{max}	★	Maximum Speed
0.637	1.27 (1.15) *4	0.637	1.27 (1.15) *4	N·m	T _R	★	Rated Torque
0.686	1.37	0.686	1.37	N·m	T _S	★	Continuous Stall Torque
2.2	4.8	2.2	4.8	N·m	T _P	★	Peak Stall Torque
1.5	1.7	1.5	2.8	Arms	I _R	★	Rated Armature Current
1.6	1.8	1.5	2.8	Arms	I _S	★	Armature Stall Current
5.6	7.1	4.8	10.8	Arms	I _P	★	Peak Armature Stall Current
0.476	0.816	0.516	0.524	N·m/Arms	K _T	☆	Torque Constant
16.6	28.5	18.0	18.3	mV/min ⁻¹	K _{Eφ}	☆	Voltage Constant for each Phase
2.7	3.3	2.3	1.36	Ω	R _φ	☆	Phase Resistance
19	39 (32) *4	8	39 (32) *4	kW/s	Q _R	★	Rated Power Rate
2.6	3.2	2.2	3.2	ms	t _e	☆	Electrical Time Constant
0.78	0.61	1.3	0.61	ms	t _m	☆	Mechanical Time Constant (Not including Encoder)
0.219	0.412	0.52	0.412	×10 ⁻⁴ kg·m ² (GD ² /4)	J _M		Rotor Inertia
0.0042*1				×10 ⁻⁴ kg·m ² (GD ² /4)	J _S		Absolute Encoder Inertia
0.99	1.5	1.4	1.5	kg	W _e		Servo Motor Mass *1
1.37 min.	1.37 min.	2.55 min.	1.37 min.	N·m	T _b		Brake Static Friction Torque
90 VDC/24 VDC±10%				V	V _b		Brake Rated Voltage
0.11/0.32	0.11/0.32	0.12/0.37	0.11/0.32	A	I _b		Brake Rated Current
0.06	0.060	0.25	0.06	×10 ⁻⁴ kg·m ² (GD ² /4)	J _b		Rotor Moment of Inertia (Brake)
0.39	0.39	0.89	0.39	kg	W		Brake Mass
0.6	1.0	0.6	1.0	kVA			Servo amplifier power supply capacity (rating)
Yes							CE and UL approved servo motors *5
IP67, IP65							Servo motor protection code
250 × 250 × 6 mm							Size of aluminum plates for heat radiation during measurement
p. 112							Page for motor dimensions

Servo Motor Operating Ambient Conditions

Operating temperature and humidity	Temp.: 0 to 40°C. Humidity: 90% max. (non-condensing)
Vibration resistance	24.5 m/s ²
Shock resistance	98 m/s ² , twice
Operation altitude	1000 m or lower above sea level
Installation location	Indoor (without direct sunlight) Location where no substance that gives adverse effects on the device and motor, such as corrosive gas, flammable gas, or dust exists

Servo Motor Model No./Flange Size/Rated Output

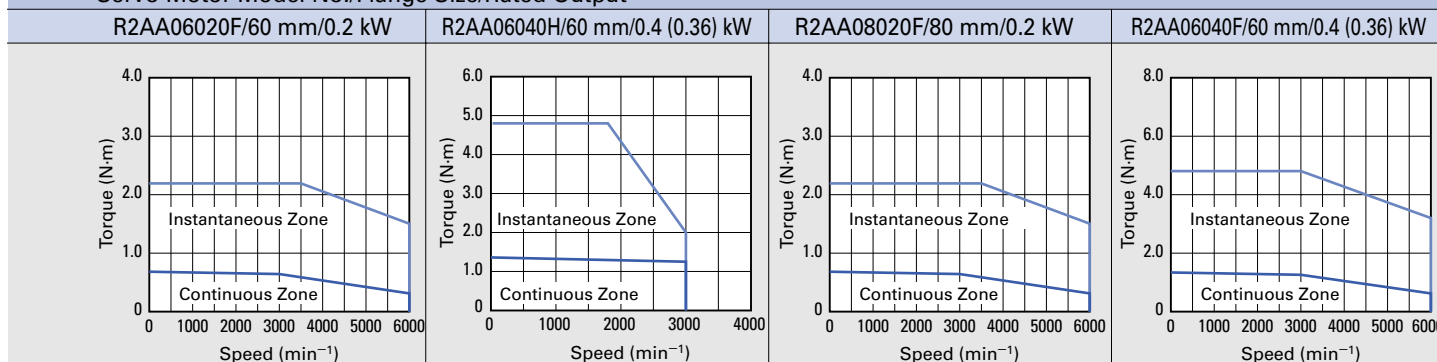

Specifications

R2 Servo Motors High Efficiency and Low Ripple (Medium Inertia) RoHS

Input voltage **200 VAC**

Servo Amplifier Model No.				R 3E Model	RS3A02□□〈20 A〉	RS3A03□□〈30 A〉	
				R ADVANCED	RS2A03□□〈30 A〉		
				R	RS1A03□□/RR1A03AAB00〈30 A〉		
Servo Motor Model No. 〈 〉 indicates flange size				R2AA08040F 〈80 mm sq.〉	R2AA08075F 〈80 mm sq.〉	R2AAB8100H 〈86 mm sq.〉	R2AA10075F 〈100 mm sq.〉
Status	Symbol	Unit					
Rated Output	★	PR	kW	0.4	0.75 ^{*4}	1.0	0.75
Rated Speed	★	NR	min ⁻¹	3000	3000	3000	3000
Maximum Speed	★	N _{max}	min ⁻¹	6000	6000	3000	6000
Rated Torque	★	TR	N·m	1.27	2.39 ^{*4}	3.18	2.39
Continuous Stall Torque	★	TS	N·m	1.37	2.55	3.92	2.55
Peak Stall Torque	★	TP	N·m	4.4	8.5	11.6	8.6
Rated Armature Current	★	IR	Arms	2.6	4.6	4.6	4.4
Armature Stall Current	★	IS	Arms	2.6	4.6	4.7	4.6
Peak Armature Stall Current	★	IP	Arms	8.9	15.5	15.5	15.5
Torque Constant	☆	KT	N·m/Arms	0.559	0.559	0.825	0.582
Voltage Constant for each Phase	☆	KEφ	mV/min ⁻¹	19.5	19.5	28.8	20.3
Phase Resistance	☆	Rφ	Ω	0.93	0.4	0.85	0.69
Rated Power Rate	★	QR	kW/s	16	31 ^{*4}	42	29
Electrical Time Constant	☆	te	ms	2.5	3	4.6	7.0
Mechanical Time Constant (Not including Encoder)	☆	tm	ms	0.93	0.7	0.89	1.2
Rotor Inertia		JM	×10 ⁻⁴ kg·m ² (GD ² /4)	1.04	1.82	2.38	2.00
Absolute Encoder Inertia		JS	×10 ⁻⁴ kg·m ² (GD ² /4)	0.0042 ^{*1}			
Servo Motor Mass ^{*1}		We	kg	1.8	2.8	3.6	3.3
Brake Static Friction Torque		Tb	N·m	2.55 min.		3.92 min.	
Brake Rated Voltage		Vb	V	90 VDC/24 VDC±10%			
Brake Rated Current		Ib	A	0.12/0.37		0.09/0.30	
Rotor Moment of Inertia (Brake)		Jb	×10 ⁻⁴ kg·m ² (GD ² /4)	0.25		0.343	
Brake Mass		W	kg	0.89	0.89	0.84	0.9
Servo amplifier power supply capacity (rating)			kVA	1.0	1.6	2.0	1.7
CE and UL approved servo motors ^{*5}				Yes			
Servo motor protection code				IP67, IP65			
Size of aluminum plates for heat radiation during measurement				250 × 250 × 6 mm		305 × 305 × 12 mm	
Page for motor dimensions				p. 112			

^{*1} Values are for motors with encoder [HA035].
For motor mass with the following encoders, contact us for details.
· Battery-backup method absolute encoder
· Wire-saving incremental encoder

^{*2} Items with ★ and speed - torque characteristics indicate values after temperature rise saturation when used with a standard servo amplifier. The values are the typical values.
^{*3} ☆ : Indicates a typical value when the winding temperature is 20°C . The values are the typical values.
^{*4} With the optional oil seals, rated outputs of servo motors might be reduced to 80 to 95% of the values in the above table.
^{*5} Our standard servo amplifiers are CE and UL approved.

Speed-Torque Characteristics

Servo Motor Model No./Flange Size/Rated Output

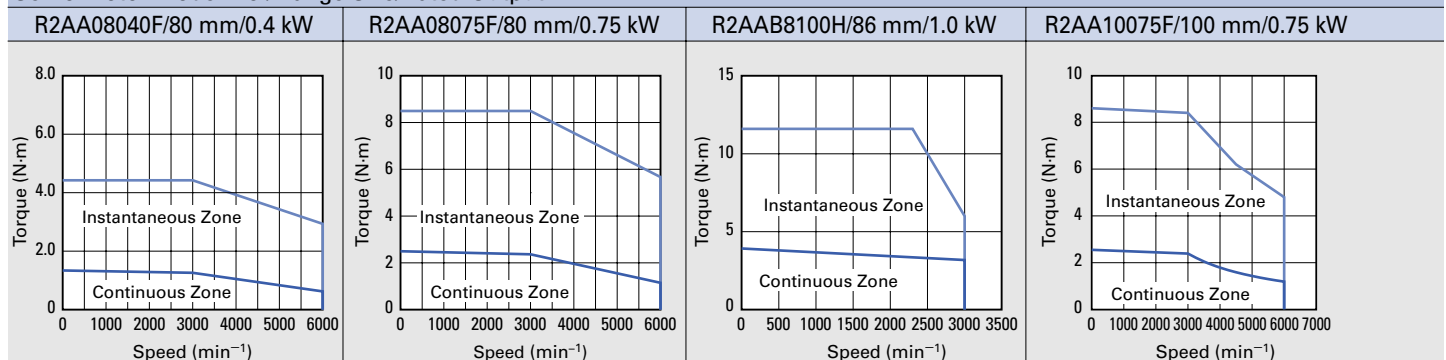

These values are for when the input voltage is a 3-phase 200 VAC circuit. The characteristics of the instantaneous zone may change when the input voltage is less than 200 VAC or single-phase 200 VAC.

RS3A03□□〈30 A〉			R 3E Model	Servo Amplifier Model No.		
RS2A03□□〈30 A〉			R ADVANCED			
RS1A03□□/RR1A03AAB00〈30 A〉			R			
R2AA13050H 〈130 mm sq.〉	R2AA13050D 〈130 mm sq.〉	R2AA13120B 〈130 mm sq.〉	Servo Motor Model No. 〈 〉 indicates flange size			
			Unit	Symbol	Status	
0.55	0.55	1.2	kW	PR	★	Rated Output
2000	2000	2000	min ⁻¹	NR	★	Rated Speed
3500	5000	2000	min ⁻¹	N _{max}	★	Maximum Speed
2.6	2.6	5.7	N·m	TR	★	Rated Torque
3.0	2.6	6.0	N·m	TS	★	Continuous Stall Torque
9.0	7.0	16	N·m	TP	★	Peak Stall Torque
4.2	5.2	5.2	Arms	IR	★	Rated Armature Current
4.6	5.2	5.2	Arms	IS	★	Armature Stall Current
15.5	15.5	15.5	Arms	IP	★	Peak Armature Stall Current
0.67	0.53	1.09	N·m/Arms	KT	☆	Torque Constant
23.5	18.5	37.8	mV/min ⁻¹	KEφ	☆	Voltage Constant for each Phase
0.65	0.39	0.64	Ω	Rφ	☆	Phase Resistance
22	22	54	kW/s	QR	★	Rated Power Rate
14	14	16	ms	te	☆	Electrical Time Constant
1.3	1.3	0.98	ms	tm	☆	Mechanical Time Constant (Not including Encoder)
3.1	3.1	6.0	×10 ⁻⁴ kg·m ² (GD ² /4)	JM		Rotor Inertia
	0.0042*1		×10 ⁻⁴ kg·m ² (GD ² /4)	JS		Absolute Encoder Inertia
4.5	4.5	6.1	kg	We		Servo Motor Mass *1
3.5 min.	3.5 min.	9.0 min.	N·m	Tb		Brake Static Friction Torque
	90 VDC/24 VDC±10%		V	Vb		Brake Rated Voltage
0.15/0.41	0.15/0.41	0.17/0.51	A	Ib		Brake Rated Current
0.5	0.5	0.5	×10 ⁻⁴ kg·m ² (GD ² /4)	Jb		Rotor Moment of Inertia (Brake)
1.3	1.3	1.5	kg	W		Brake Mass
1.2	1.2	2.2	kVA			Servo amplifier power supply capacity (rating)
	Yes					CE and UL approved servo motors *5
	IP65					Servo motor protection code
305 × 305 × 20 mm		400 × 400 × 20 mm				Size of aluminum plates for heat radiation during measurement
p. 113						Page for motor dimensions

Servo Motor Operating Ambient Conditions

Operating temperature and humidity	Temp.: 0 to 40°C. Humidity: 90% max. (non-condensing)
Vibration resistance	24.5 m/s ²
Shock resistance	98 m/s ² , twice
Operation altitude	1000 m or lower above sea level
Installation location	Indoor (without direct sunlight) Location where no substance that gives adverse effects on the device and motor, such as corrosive gas, flammable gas, or dust exists

Servo Motor Model No./Flange Size/Rated Output

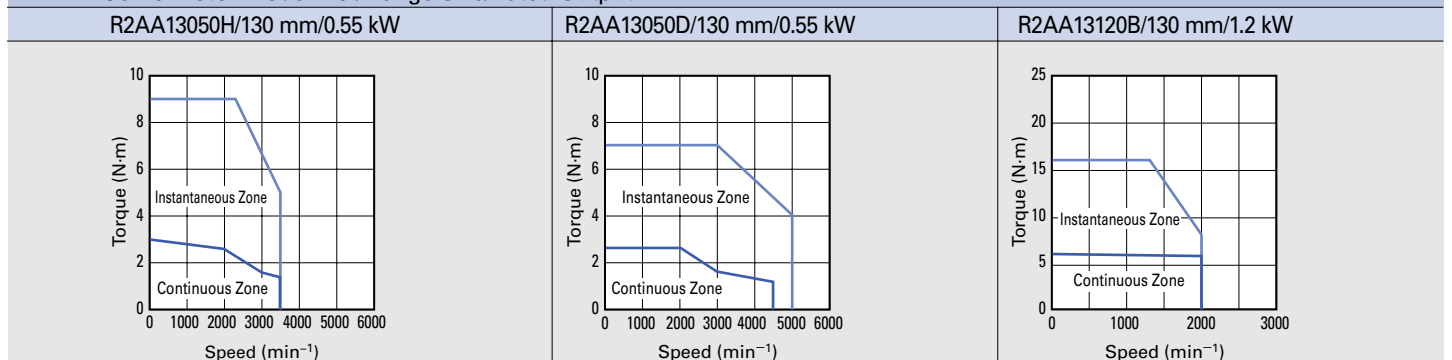

Specifications

R2 Servo Motors High Efficiency and Low Ripple (Medium Inertia) RoHS

Input voltage **200 VAC**

Servo Amplifier Model No.				R 3E Model				
				RS3A05 □ □ (50 A)				
Servo Motor Model No. () indicates flange size				R ADVANCED				
				RS2A05 □ □ (50 A)				
Servo Motor Model No. () indicates flange size				R				
				RS1A05 □ □ (50 A)				
Status	Symbol	Unit	R2AAB8075F 《86 mm sq.》	R2AAB8100F 《86 mm sq.》	R2AA10100F 《100 mm sq.》	R2AA13120L 《130 mm sq.》		
Rated Output	★	PR	kW	0.75	1.0	1.0	1.2	
Rated Speed	★	NR	min ⁻¹	3000	3000	3000	2000	
Maximum Speed	★	N _{max}	min ⁻¹	6000	6000	6000	3000	
Rated Torque	★	TR	N·m	2.38	3.18	3.18	5.7	
Continuous Stall Torque	★	TS	N·m	2.94	3.92	3.92	6.0	
Peak Stall Torque	★	TP	N·m	11.0	14.3	14.3	20	
Rated Armature Current	★	IR	Arms	4.7	6.0	5.7	7.6	
Armature Stall Current	★	IS	Arms	5.5	6.8	6.8	8.4	
Peak Armature Stall Current	★	IP	Arms	23.7	25.7	25.7	26.5	
Torque Constant	☆	KT	N·m/Arms	0.547	0.582	0.584	0.77	
Voltage Constant for each Phase	☆	KEφ	mV/min ⁻¹	19.1	20.3	20.4	27.0	
Phase Resistance	☆	Rφ	Ω	0.62	0.44	0.35	0.35	
Rated Power Rate	★	QR	kW/s	35	42	29	54	
Electrical Time Constant	☆	te	ms	4.2	4.3	8.3	15	
Mechanical Time Constant (Not including Encoder)	☆	tm	ms	1.00	0.93	1.1	1.1	
Rotor Inertia		JM	X10 ⁻⁴ kg·m ² (GD ² /4)	1.64	2.38	3.50	6.0	
Absolute Encoder Inertia		JS	X10 ⁻⁴ kg·m ² (GD ² /4)	0.0042*1				
Servo Motor Mass *1		We	kg	2.9	3.6	4.1	6.1	
Brake Static Friction Torque		Tb	N·m	3.92 min.	3.92 min.	3.92 min.	9.0 min.	
Brake Rated Voltage		Vb	V	90 VDC/24 VDC±10%				
Brake Rated Current		Ib	A	0.09/0.30	0.09/0.30	0.09/0.30	0.17/0.51	
Rotor Moment of Inertia (Brake)		Jb	X10 ⁻⁴ kg·m ² (GD ² /4)	0.34	0.34	0.343	0.5	
Brake Mass		W	kg	0.84	0.84	0.9	1.5	
Servo amplifier power supply capacity (rating)			kVA	1.6	2.3	2.3	2.8	
CE and UL approved servo motors *4				Yes				
Servo motor protection code				IP67, IP65			IP65	
Size of aluminum plates for heat radiation during measurement				305 × 305 × 12 mm			400 × 400 × 20 mm	
Page for motor dimensions				p. 112			p. 113	

*1 Values are for motors with encoder [HA035].
For motor mass with the following encoders, contact us for details.
· Battery-backup method absolute encoder
· Wire-saving incremental encoder

*2 Items with ★ and speed - torque characteristics indicate values after temperature rise saturation when used with a standard servo amplifier. The values are the typical values.

*3 ☆ : Indicates a typical value when the winding temperature is 20°C . The values are the typical values.

*4 Our standard servo amplifiers are CE and UL approved.

Speed-Torque Characteristics

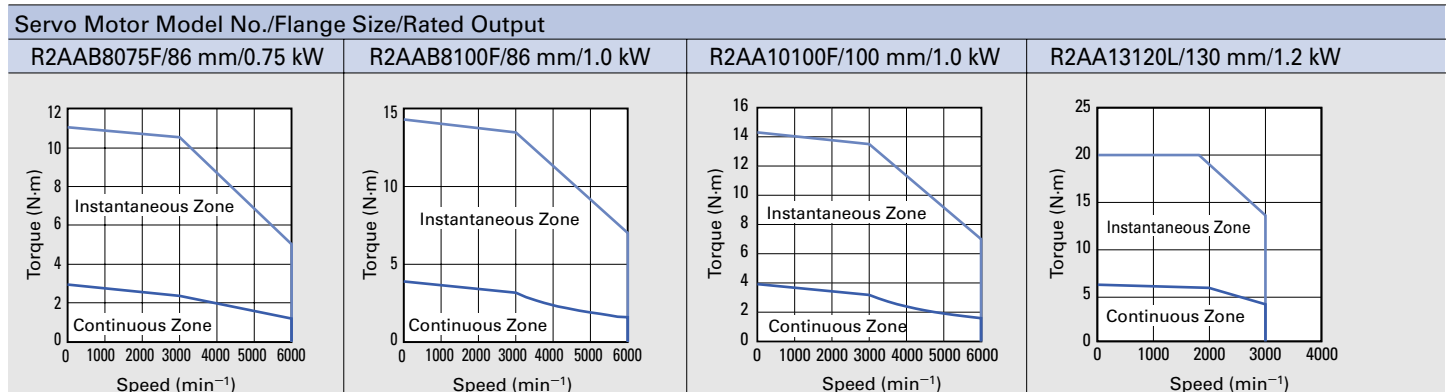

These values are for when the input voltage is a 3-phase 200 VAC circuit. The characteristics of the instantaneous zone may change when the input voltage is less than 200 VAC or single-phase 200 VAC.

RS3A05□□《50 A》		RS3A10□□《100 A》		R 3E Model	Servo Amplifier Model No.		
RS2A05□□《50 A》		RS2A10□□《100 A》		R ADVANCED			
RS1A05□□《50 A》		RS1A10□□《100 A》		R			
R2AA13120D 《130 mm sq.》	R2AA13180H 《130 mm sq.》	R2AA13200L 《130 mm sq.》	R2AA13180D 《130 mm sq.》	Servo Motor Model No. 《 》 indicates flange size			
				Unit	Symbol	Status	
1.2	1.8	2	1.8	kW	PR	★	Rated Output
2000	2000	2000	2000	min ⁻¹	NR	★	Rated Speed
5000	3500	3000	5000	min ⁻¹	N _{max}	★	Maximum Speed
5.7	8.6	9.5	8.6	N·m	TR	★	Rated Torque
6.0	10.0	12	10.0	N·m	TS	★	Continuous Stall Torque
16	22	24	25	N·m	TP	★	Peak Stall Torque
9.1	11.0	11.0	15.6	Arms	IR	★	Rated Armature Current
9.3	11.8	12.0	17.3	Arms	IS	★	Armature Stall Current
25.4	26.5	26.5	43.0	Arms	IP	★	Peak Armature Stall Current
0.65	0.89	0.97	0.63	N·m/Arms	KT	☆	Torque Constant
22.7	31.1	33.7	21.8	mV/min ⁻¹	KEφ	☆	Voltage Constant for each Phase
0.23	0.23	0.22	0.13	Ω	Rφ	☆	Phase Resistance
54	82	74	82	kW/s	QR	★	Rated Power Rate
16	18	17	16	ms	te	☆	Electrical Time Constant
0.98	0.78	0.86	0.89	ms	tm	☆	Mechanical Time Constant (Not including Encoder)
6.0	9.0	12.2	9.0	×10 ⁻⁴ kg·m ² (GD ² /4)	JM		Rotor Inertia
0.0042*1				×10 ⁻⁴ kg·m ² (GD ² /4)	Js		Absolute Encoder Inertia
6.1	7.7	10	7.7	kg	We		Servo Motor Mass *1
9.0 min.	9.0 min.	12 min.	9.0 min.	N·m	Tb		Brake Static Friction Torque
90 VDC/24 VDC±10%				V	Vb		Brake Rated Voltage
0.17/0.51	0.17/0.51	0.17/0.66	0.17/0.51	A	Ib		Brake Rated Current
0.5	0.5	0.5	0.5	×10 ⁻⁴ kg·m ² (GD ² /4)	Jb		Rotor Moment of Inertia (Brake)
1.5	1.5	1.5	1.5	kg	W		Brake Mass
2.8	3.6	4.0	4.0	kVA			Servo amplifier power supply capacity (rating)
Yes							CE and UL approved servo motors *4
IP65							Servo motor protection code
400 × 400 × 20 mm	470 × 470 × 20 mm						Size of aluminum plates for heat radiation during measurement
p. 113		p. 114		p. 113			Page for motor dimensions

Servo Motor Operating Ambient Conditions

Operating temperature and humidity	Temp.: 0 to 40°C. Humidity: 90% max. (non-condensing)
Vibration resistance	24.5 m/s ²
Shock resistance	98 m/s ² , twice
Operation altitude	1000 m or lower above sea level
Installation location	Indoor (without direct sunlight) Location where no substance that gives adverse effects on the device and motor, such as corrosive gas, flammable gas, or dust exists

Servo Motor Model No./Flange Size/Rated Output

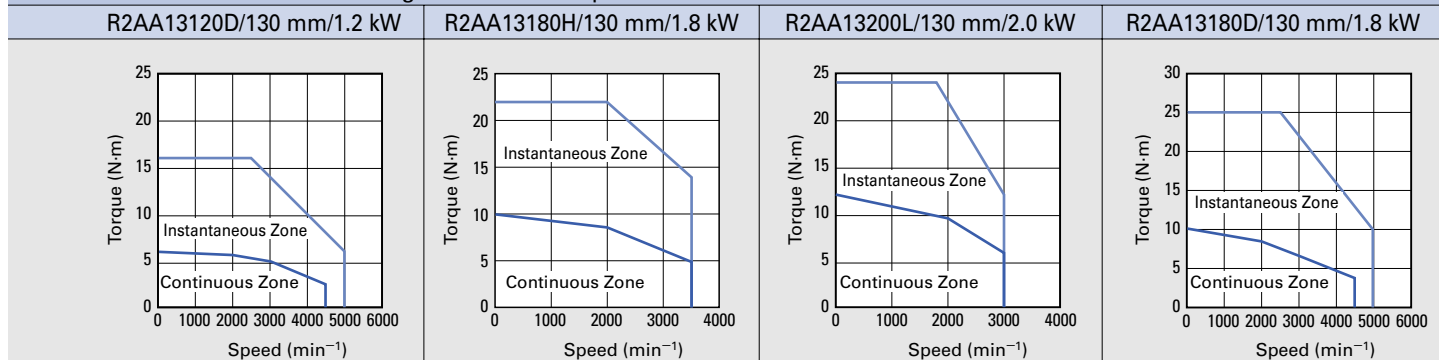

Specifications

R2 Servo Motors High Efficiency and Low Ripple (Medium Inertia) RoHS

Input voltage **200 VAC**

Servo Amplifier Model No.				R 3E Model		RS3A10□□〈100 A〉		RS3A15□□〈150 A〉	
				R ADVANCED		RS2A10□□〈100 A〉		RS2A15□□〈150 A〉	
				R		RS1A10□□〈100 A〉		RS1A15□□〈150 A〉	
Servo Motor Model No. 〈 〉 indicates flange size				R2AA13200D 〈130 mm sq.〉	R2AA18350L 〈180 mm sq.〉	R2AA18350D 〈180 mm sq.〉	R2AA18450H 〈180 mm sq.〉		
Status	Symbol	Unit							
Rated Output	★	PR	kW	2	3.5	3.5	4.5		
Rated Speed	★	NR	min ⁻¹	2000	2000	2000	2000		
Maximum Speed	★	N _{max}	min ⁻¹	5000	3000	4000	3500		
Rated Torque	★	TR	N·m	9.5	17	17	21.5		
Continuous Stall Torque	★	TS	N·m	12	22.0	22.0	30.0		
Peak Stall Torque	★	TP	N·m	30	49	60	75		
Rated Armature Current	★	IR	Arms	14.3	19.1	21.7	23.7		
Armature Stall Current	★	IS	Arms	17.5	23.7	27.0	31.7		
Peak Armature Stall Current	★	IP	Arms	45.5	55.0	83.0	83.0		
Torque Constant	☆	KT	N·m/Arms	0.70	1.00	0.88	1.02		
Voltage Constant for each Phase	☆	KEφ	mV/min ⁻¹	24.3	34.8	30.6	35.6		
Phase Resistance	☆	Rφ	Ω	0.11	0.085	0.075	0.065		
Rated Power Rate	★	QR	kW/s	74	72	72	92		
Electrical Time Constant	☆	te	ms	18	18	16	18		
Mechanical Time Constant (Not including Encoder)	☆	tm	ms	0.83	1.0	1.2	0.94		
Rotor Inertia		JM	×10 ⁻⁴ kg·m ² (GD ² /4)	12.2	40	40	50		
Absolute Encoder Inertia		JS	×10 ⁻⁴ kg·m ² (GD ² /4)	0.012*1					
Servo Motor Mass *1		We	kg	10	15.5	15.5	19.5		
Brake Static Friction Torque		Tb	N·m	12 min.	22 min.	22 min.	32 min.		
Brake Rated Voltage		Vb	V	90 VDC/24 VDC±10%					
Brake Rated Current		Ib	A	0.17/0.66	0.32/1.2	0.32/1.2	0.27/1.0		
Rotor Moment of Inertia (Brake)		Jb	×10 ⁻⁴ kg·m ² (GD ² /4)	0.5	5.1	5.1	5.1		
Brake Mass		W	kg	1.5	2.4	2.4	2.8		
Servo amplifier power supply capacity (rating)			kVA	5.0	6.0	7.0	7.4		
CE and UL approved servo motors *4				Yes					
Servo motor protection code				IP65					
Size of aluminum plates for heat radiation during measurement				470 × 470 × 20 mm					
Page for motor dimensions				p. 114	p. 115				

*1 Values are for motors with encoder [HA035].
For motor mass with the following encoders, contact us for details.
· Battery-backup method absolute encoder
· Wire-saving incremental encoder

*2 Items with ★ and speed - torque characteristics indicate values after temperature rise saturation when used with a standard servo amplifier. The values are the typical values.

*3 ☆ : Indicates a typical value when the winding temperature is 20°C . The values are the typical values.

*4 Our standard servo amplifiers are CE and UL approved.

Speed-Torque Characteristics

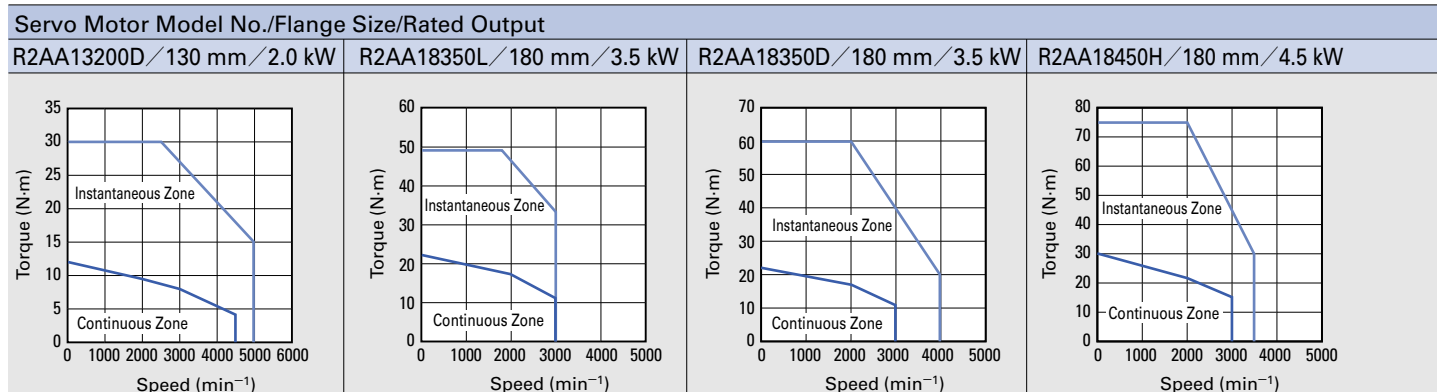

These values are for when the input voltage is a 3-phase 200 VAC circuit. The characteristics of the instantaneous zone may change when the input voltage is less than 200 VAC.

RS3A15□□〈150 A〉		RS3A30□□〈300 A〉		R 3E Model	Servo Amplifier Model No.		
RS2A15□□〈150 A〉		RS2A30□□〈300 A〉		R ADVANCED			
RS1A15□□〈150 A〉		RS1A30□□〈300 A〉		R			
R2AA18550R 〈180 mm sq.〉	R2AA22500L 〈220 mm sq.〉	R2AA22700S 〈220 mm sq.〉	R2AA18550H 〈180 mm sq.〉	Servo Motor Model No. 〈 〉 indicates flange size			
				Unit	Symbol	Status	
5.5	5	7	5.5	kW	PR	★	Rated Output
1500	2000	1000	1500	min ⁻¹	NR	★	Rated Speed
2500	4000	1000	3000	min ⁻¹	N _{max}	★	Maximum Speed
35	24	67	35	N·m	TR	★	Rated Torque
37.3	32	70	37.5	N·m	TS	★	Continuous Stall Torque
90	75	150	107	N·m	TP	★	Peak Stall Torque
31.6	22.0	34.0	46.2	Arms	IR	★	Rated Armature Current
32.9	34.0	34.0	48.0	Arms	IS	★	Armature Stall Current
83.0	83.0	83.0	155.0	Arms	IP	★	Peak Armature Stall Current
1.23	1.00	2.25	0.84	N·m/Arms	KT	☆	Torque Constant
42.8	34.9	78.6	29.3	mV/min ⁻¹	KEφ	☆	Voltage Constant for each Phase
0.059	0.047	0.085	0.030	Ω	Rφ	☆	Phase Resistance
180	105	330	180	kW/s	QR	★	Rated Power Rate
22	40	26	20	ms	te	☆	Electrical Time Constant
0.80	0.78	0.68	0.87	ms	tm	☆	Mechanical Time Constant (Not including Encoder)
68	55	136	68	×10 ⁻⁴ kg·m ² (GD ² /4)	JM		Rotor Inertia
0.012* ¹				×10 ⁻⁴ kg·m ² (GD ² /4)	JS		Absolute Encoder Inertia
27.7	22.5	43	27.7	kg	We		Servo Motor Mass * ¹
42 min.	42 min.	90 min.	42 min.	N·m	Tb		Brake Static Friction Torque
90 VDC/24 VDC±10%				V	Vb		Brake Rated Voltage
0.27/1.0	0.32/1.2	0.44/1.7	0.27/1.0	A	Ib		Brake Rated Current
5.1	5.1	24	5.1	×10 ⁻⁴ kg·m ² (GD ² /4)	Jb		Rotor Moment of Inertia (Brake)
2.8	5.5	7.8	2.8	kg	W		Brake Mass
8.4	9.6	12.2	9.3	kVA			Servo amplifier power supply capacity (rating)
Yes							CE and UL approved servo motors * ⁴
IP65							Servo motor protection code
540 × 540 × 20 mm							Size of aluminum plates for heat radiation during measurement
p. 115	p. 116		p. 115				Page for motor dimensions

Servo Motor Operating Ambient Conditions

Operating temperature and humidity	Temp.: 0 to 40°C. Humidity: 90% max. (non-condensing)
Vibration resistance	24.5 m/s ²
Shock resistance	98 m/s ² , twice
Operation altitude	1000 m or lower above sea level
Installation location	Indoor (without direct sunlight) Location where no substance that gives adverse effects on the device and motor, such as corrosive gas, flammable gas, or dust exists

Servo Motor Model No./Flange Size/Rated Output

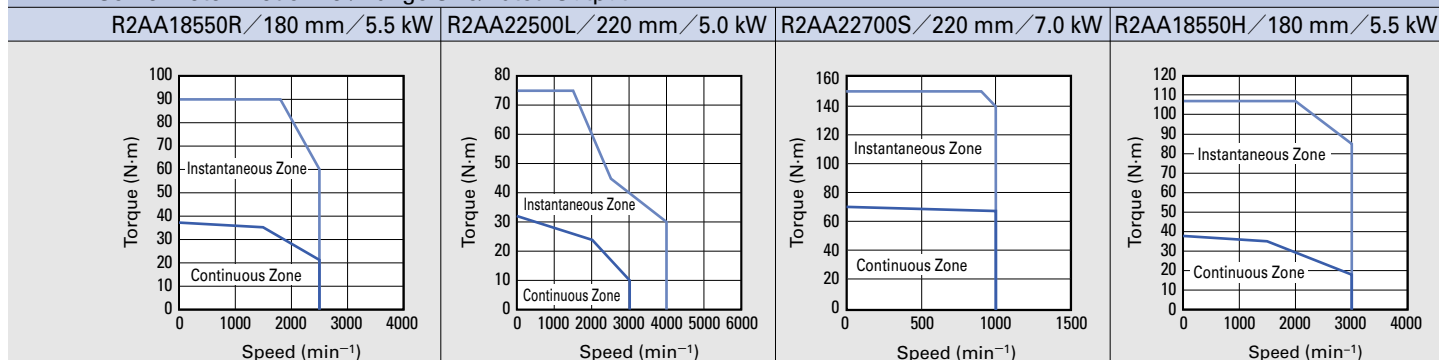

Specifications

R2 Servo Motors High Efficiency and Low Ripple (Medium Inertia) RoHS

Input voltage **200 VAC**

Servo Amplifier Model No.				R 3E Model			
				R ADVANCED			
				R			
Servo Motor Model No. () indicates flange size				R2AA18750H (180 mm sq.)	R2AA1811KR (180 mm sq.)	R2AA2211KB (220 mm sq.)	R2AA2215KB (220 mm sq.)
Status	Symbol	Unit					
Rated Output	★	PR	kW	7.5	11	11	15
Rated Speed	★	NR	min ⁻¹	1500	1500	1500	1500
Maximum Speed	★	N _{max}	min ⁻¹	3000	2500	2000	2000
Rated Torque	★	TR	N·m	48	70	70	95
Continuous Stall Torque	★	TS	N·m	54.9	80.0	80	95
Peak Stall Torque	★	TP	N·m	140	170	176	215
Rated Armature Current	★	IR	Arms	51.2	61.9	60	66
Armature Stall Current	★	IS	Arms	56.8	66.0	66	66
Peak Armature Stall Current	★	IP	Arms	155.0	155.0	155	155
Torque Constant	☆	KT	N·m/Arms	1.04	1.25	1.38	1.50
Voltage Constant for each Phase	☆	KEφ	mV/min ⁻¹	36.6	43.8	48	52.3
Phase Resistance	☆	Rφ	Ω	0.030	0.035	0.022	0.017
Rated Power Rate	★	QR	kW/s	235	445	275	380
Electrical Time Constant	☆	te	ms	20	22	27	34
Mechanical Time Constant (Not including Encoder)	☆	tm	ms	0.81	0.74	0.62	0.54
Rotor Inertia		JM	X10 ⁻⁴ kg·m ² (GD ² /4)	98	110	178	237
Absolute Encoder Inertia		JS	X10 ⁻⁴ kg·m ² (GD ² /4)	0.012*1			
Servo Motor Mass *1		We	kg	35.7	40	55	62
Brake Static Friction Torque		Tb	N·m	54.9 min.	100 min.	90 min.	
Brake Rated Voltage		Vb	V	90 VDC/24 VDC±10%			
Brake Rated Current		Ib	A	0.37/1.4	0.5/1.9	0.44/1.7	
Rotor Moment of Inertia (Brake)		Jb	X10 ⁻⁴ kg·m ² (GD ² /4)	4.5	9.7	24	
Brake Mass		W	kg	4.5	8.9	7.8	
Servo amplifier power supply capacity (rating)			kVA	11.6	16.0	16.0	21.4
Cooling fan power		Pf	W	—	31/29 180 VAC to 253 VAC Single-phase 50 Hz/60 Hz	—	
CE and UL approved servo motors *4				Yes			
Servo motor protection code				IP65	IP65 (excluding the cooling fan)	IP65	
Size of aluminum plates for heat radiation during measurement				540 × 540 × 20 mm	610 × 610 × 30 mm		
Page for motor dimensions				p. 115			p. 116

*1 Values are for motors with encoder [HA035].
For motor mass with the following encoders, contact us for details.
· Battery-backup method absolute encoder
· Wire-saving incremental encoder

*2 Items with ★ and speed - torque characteristics indicate values after temperature rise saturation when used with a standard servo amplifier. The values are the typical values.

*3 ☆ : Indicates a typical value when the winding temperature is 20°C . The values are the typical values.

*4 Our standard servo amplifiers are CE and UL approved.

Speed-Torque Characteristics

Servo Motor Model No./Flange Size/Rated Output

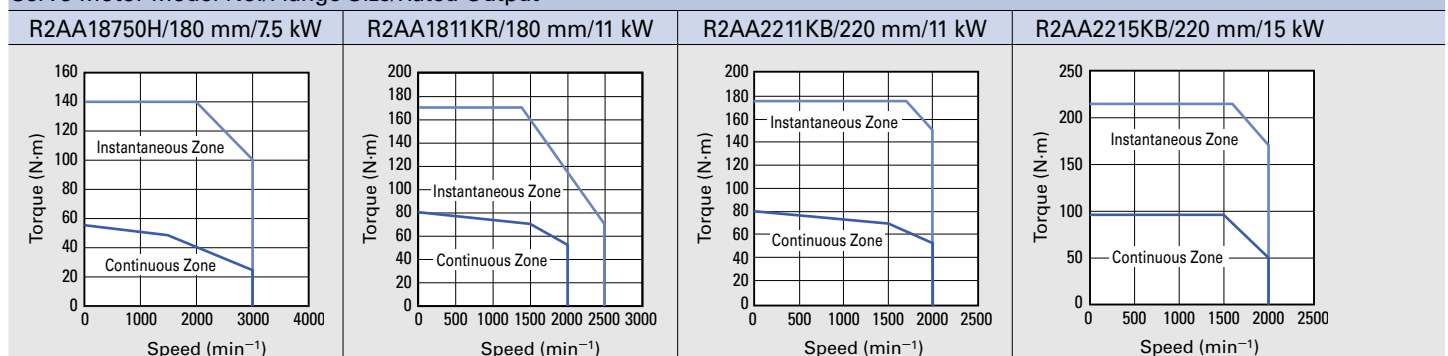

These values are for when the input voltage is a 3-phase 200 VAC circuit. The characteristics of the instantaneous zone may change when the input voltage is less than 200 VAC.

RS3W60□□《600 A》		R 3E Model	Servo Amplifier Model No.		
—		R ADVANCED			
—		R			
R2AA2220KB 《220 mm sq.》	R2AA2830KV 《275 mm sq.》	Servo Motor Model No. 《 》 indicates flange size			
		Unit	Symbol	Status	
20	30	kW	PR	★	Rated Output
1500	1500	min ⁻¹	NR	★	Rated Speed
2000	2000	min ⁻¹	N _{max}	★	Maximum Speed
125	191.1	N·m	TR	★	Rated Torque
125	191.1	N·m	TS	★	Continuous Stall Torque
280	480	N·m	TP	★	Peak Stall Torque
116	116	Arms	IR	★	Rated Armature Current
113	114	Arms	IS	★	Armature Stall Current
290	290	Arms	IP	★	Peak Armature Stall Current
1.21	1.78	N·m/Arms	KT	☆	Torque Constant
42.4	62.1	mV/min ⁻¹	KEφ	☆	Voltage Constant for each Phase
0.013	0.013	Ω	Rφ	☆	Phase Resistance
659	865	kW/s	QR	★	Rated Power Rate
33	59	ms	te	☆	Electrical Time Constant
0.63	0.52	ms	tm	☆	Mechanical Time Constant (Not including Encoder)
237	422	×10 ⁻⁴ kg·m ² (GD ² /4)	JM		Rotor Inertia
0.012*1		×10 ⁻⁴ kg·m ² (GD ² /4)	JS		Absolute Encoder Inertia
73	107	kg	We		Servo Motor Mass *1
170 min.	191.2 min.	N·m	Tb		Brake Static Friction Torque
24 VDC±10%		V	Vb		Brake Rated Voltage
1.5	2.6	A	Ib		Brake Rated Current
12	11.8	×10 ⁻⁴ kg·m ² (GD ² /4)	Jb		Rotor Moment of Inertia (Brake)
17	18.2	kg	W		Brake Mass
30.0	42.0	kVA			Servo amplifier power supply capacity (rating)
65/65 180 VAC to 253 VAC 3-phase 50 Hz/60 Hz		W	Pf		Cooling fan power
Yes	Preparing				CE and UL approved servo motors *4
IP65 (excluding the cooling fan)					Servo motor protection code
610 × 610 × 30 mm					Size of aluminum plates for heat radiation during measurement
p. 117					Page for motor dimensions

Servo Motor Operating Ambient Conditions

Operating temperature and humidity	Temp.: 0 to 40°C. Humidity: 90% max. (non-condensing)
Vibration resistance	24.5 m/s ²
Shock resistance	98 m/s ² , twice
Operation altitude	1000 m or lower above sea level
Installation location	Indoor (without direct sunlight) Location where no substance that gives adverse effects on the device and motor, such as corrosive gas, flammable gas, or dust exists

Servo Motor Model No./Flange Size/Rated Output

R2AA2220KB/220 mm/20 kW

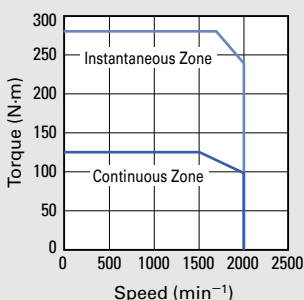

R2AA2830KV/275 mm/30 kW

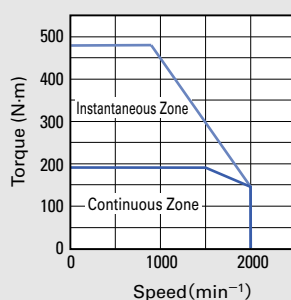

Specifications

R1 Servo Motors High Power Rate (Low Inertia) RoHS

Input voltage **200 VAC**

Servo Amplifier Model No.				R 3E Model		RS3A30□□〈300 A〉	
				R ADVANCED		RS2A30□□〈300 A〉	
				R		RS1A30□□〈300 A〉	
Servo Motor Model No. 〈 〉 indicates flange size				R1AA18550H 〈180 mm sq.〉		R1AA18750L 〈180 mm sq.〉	
	Status	Symbol	Unit				
Rated Output	★	PR	kW	5.5		7.5	
Rated Speed	★	NR	min ⁻¹	1500		1500	
Maximum Speed	★	N _{max}	min ⁻¹	3000		3000	
Rated Torque	★	TR	N·m	35		48	
Continuous Stall Torque	★	TS	N·m	37		48	
Peak Stall Torque	★	TP	N·m	110		135	
Rated Armature Current	★	IR	Arms	46		49	
Armature Stall Current	★	IS	Arms	47		47	
Peak Armature Stall Current	★	IP	Arms	155		155	
Torque Constant	☆	K _T	N·m/Arms	0.86		1.09	
Voltage Constant for each Phase	☆	K _{Eφ}	mV/min ⁻¹	30		38.1	
Phase Resistance	☆	R _φ	Ω	0.029		0.031	
Rated Power Rate	★	QR	kW/s	370		550	
Electrical Time Constant	☆	t _e	ms	23		21	
Mechanical Time Constant (Not including Encoder)	☆	t _m	ms	0.39		0.33	
Rotor Inertia		J _M	×10 ⁻⁴ kg·m ² (GD ² /4)	33		42	
Servo Motor Mass *1		W _e	kg	33		39	
Brake Static Friction Torque		T _b	N·m	53.9 min.		53.9 min.	
Brake Rated Voltage		V _b	V	90 VDC/24 VDC±10%			
Brake Rated Current		I _b	A	0.37/1.4		0.37/1.4	
Rotor Moment of Inertia (Brake)		J _b	×10 ⁻⁴ kg·m ² (GD ² /4)	5.7		5.7	
Brake Mass		W	kg	5		5	
Servo amplifier power supply capacity (rating)			kVA	9.3		11.6	
Cooling fan power		P _F	W	30/26 200 VAC±10% Single-phase 50 Hz/60 Hz For CE/UL compliant products: 31/29 180 VAC to 253 VAC Single-phase 50 Hz/60 Hz			
CE and UL approved servo motors *4				Yes			
Servo motor protection code				IP65 (excluding the cooling fan)			
Size of aluminum plates for heat radiation during measurement				540 × 540 × 20 mm			
Page for motor dimensions				p. 118			

*1 Values are for motors with encoder [HA035].
For motor mass with the following encoders, contact us for details.
· Battery-backup method absolute encoder
· Wire-saving incremental encoder

*2 Items with ★ and speed - torque characteristics indicate values after temperature rise saturation when used with a standard servo amplifier. The values are the typical values.

*3 ☆ : Indicates a typical value when the winding temperature is 20°C . The values are the typical values.

*4 Our standard servo amplifiers are CE and UL approved.

Speed-Torque Characteristics

Servo Motor Model No./Flange Size/Rated Output

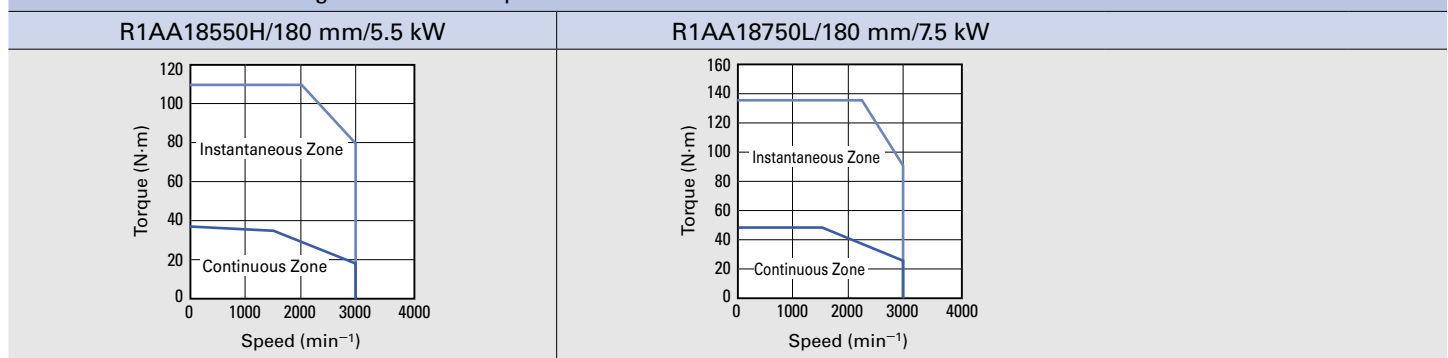

These values are for when the input voltage is a 3-phase 200 VAC circuit. The characteristics of the instantaneous zone may change when the input voltage is less than 200 VAC or single-phase 200 VAC.

RS3A30A □ □ 《300 A》		RS3W60 □ □ 《600 A》		R 3E Model		Servo Amplifier Model No.
RS2A30 □ □ 《300 A》		—		R ADVANCED		
RS1A30 □ □ 《300 A》		—		R		
R1AA1811KR 《180 mm sq.》	R1AA1815KB 《180 mm sq.》	R1AA2220KV 《220 mm sq.》		Servo Motor Model No. 《 》 indicates flange size		
			Unit	Symbol	Status	
11	15	21		kW	PR	★ Rated Output
1500	1500	1500		min ⁻¹	NR	★ Rated Speed
2500	2000	2000		min ⁻¹	N _{max}	★ Maximum Speed
70	95.5	135		N·m	TR	★ Rated Torque
70	95.5	135		N·m	TS	★ Continuous Stall Torque
195	230	380		N·m	TP	★ Peak Stall Torque
55.0	60.0	100		Arms	IR	★ Rated Armature Current
54.0	58.0	96		Arms	IS	★ Armature Stall Current
155	155	290		Arms	IP	★ Peak Armature Stall Current
1.4	1.77	1.51		N·m/Arms	KT	☆ Torque Constant
48.7	61.6	52.8		mV/min ⁻¹	KEφ	☆ Voltage Constant for each Phase
0.033	0.033	0.014		Ω	Rφ	☆ Phase Resistance
770	1060	1740		kW/s	QR	★ Rated Power Rate
22	25	51		ms	te	☆ Electrical Time Constant
0.32	0.27	0.19		ms	tm	☆ Mechanical Time Constant (Not including Encoder)
64	86	105		×10 ⁻⁴ kg·m ² (GD ² /4)	JM	Rotor Inertia
52	64	107		kg	We	Servo Motor Mass * ¹
75 min.	120 min.	—		N·m	Tb	Brake Static Friction Torque
24 VDC ±10%			—	V	Vb	Brake Rated Voltage
1.5	1.9	—		A	Ib	Brake Rated Current
8.0	9.7	—		×10 ⁻⁴ kg·m ² (GD ² /4)	Jb	Rotor Moment of Inertia (Brake)
7	9	—		kg	W	Brake Mass
16.0	21.4	30.0		kVA		Servo amplifier power supply capacity (rating)
30/26 200 VAC ±10% Single-phase 50 Hz/60 Hz				W	PF	Cooling fan power
For CE/UL compliant products: 31/29 180 VAC to 253 VAC Single-phase 50 Hz/60 Hz						
Yes						CE and UL approved servo motors * ⁴
IP65 (excluding the cooling fan)						Servo motor protection code
610 × 610 × 30 mm						Size of aluminum plates for heat radiation during measurement
p. 118						Page for motor dimensions

Servo Motor Operating Ambient Conditions

Operating temperature and humidity	Temp.: 0 to 40°C. Humidity: 90% max. (non-condensing)
Vibration resistance	24.5 m/s ²
Shock resistance	98 m/s ² , twice
Operation altitude	1000 m or lower above sea level
Installation location	Indoor (without direct sunlight) Location where no substance that gives adverse effects on the device and motor, such as corrosive gas, flammable gas, or dust exists

Servo Motor Model No./Flange Size/Rated Output

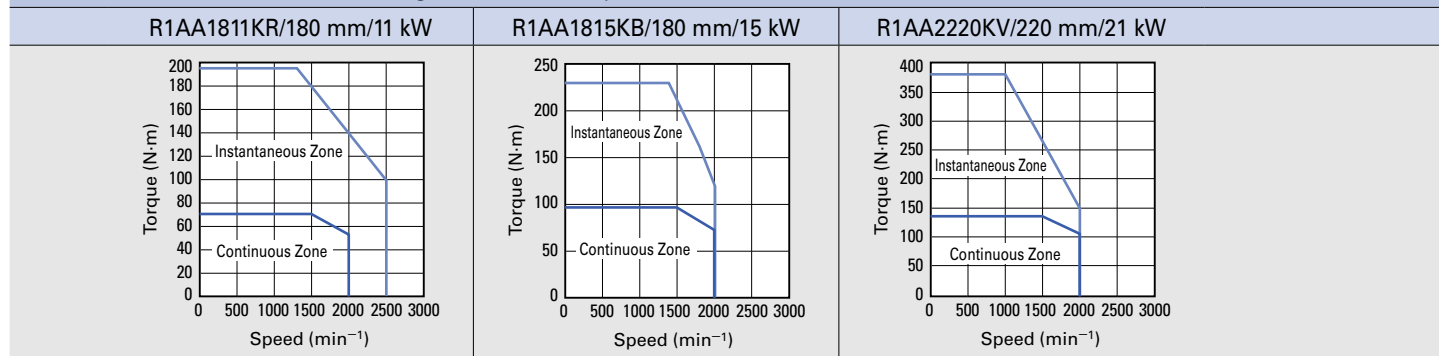

Specifications

R5 Servo Motors High Efficiency and Ultra Low Ripple (Medium Inertia) Low cogging torque RoHS

Input voltage **200 VAC**

Servo Amplifier Model No.				R 3E Model	RS3A01□□〈10 A〉	RS3A02□□〈20 A〉	RS3A03□□〈30 A〉
				R ADVANCED	RS2A01□□〈15 A〉		RS2A03□□〈30 A〉
				R	RS1A01□□〈15 A〉		RS1A03□□〈30 A〉
Servo Motor Model No. 〈 〉 indicates flange size				R5AA06020H 〈60 mm sq.〉	R5AA06040H 〈60 mm sq.〉	R5AA08075D 〈80 mm sq.〉	
	Status	Symbol	Unit				
Rated Output	★	PR	kW	0.2	0.4 (0.38) *4	0.75 (0.71) *4	
Rated Speed	★	NR	min ⁻¹	3000	3000	3000	
Maximum Speed	★	N _{max}	min ⁻¹	3000	3000	5000	
Rated Torque	★	TR	N·m	0.637	1.27 (1.21) *4	2.39 (2.27) *4	
Continuous Stall Torque	★	TS	N·m	0.686	1.37	2.55	
Peak Stall Torque	★	TP	N·m	2.2	4.8	8.5	
Rated Armature Current	★	IR	Arms	1.1	1.8	3.9	
Armature Stall Current	★	IS	Arms	1.1	1.8	3.9	
Peak Armature Stall Current	★	IP	Arms	4.2	7.0	14.4	
Torque Constant	☆	KT	N·m/Arms	0.649	0.836	0.763	
Voltage Constant for each Phase	☆	KEφ	mV/min ⁻¹	21.7	27.0	23.2	
Phase Resistance	☆	Rφ	Ω	4.8	3.3	0.78	
Rated Power Rate	★	QR	kW/s	20	39 (35) *4	35 (31) *4	
Electrical Time Constant	☆	te	ms	4.3	5.5	13	
Mechanical Time Constant (Not including Encoder)	☆	tm	ms	0.71	0.63	0.76	
Rotor Inertia		JM	X10 ⁻⁴ kg·m ² (GD ² /4)	0.198	0.414	1.65	
Absolute Encoder Inertia		JS	X10 ⁻⁴ kg·m ² (GD ² /4)	0.0042*1			
Servo Motor Mass *1		We	kg	0.99	1.5	2.8	
Brake Static Friction Torque		Tb	N·m	1.37 min.		2.55 min.	
Brake Rated Voltage		Vb	V	90 VDC/24 VDC±10%			
Brake Rated Current		Ib	A	0.11/0.32		0.12/0.37	
Rotor Moment of Inertia (Brake)		Jb	X10 ⁻⁴ kg·m ² (GD ² /4)	0.060	0.060	0.25	
Brake Mass		W	kg	0.39	0.39	0.89	
Servo amplifier power supply capacity (rating)			kVA	0.6	1.0	1.6	
CE and UL approved servo motors *5				Yes			
Servo motor protection code				IP65			
Size of aluminum plates for heat radiation during measurement				250 × 250 × 6 mm			
Page for motor dimensions				p. 112			

*1 Values are for motors with encoder [HA035].
For motor mass with the following encoders, contact us for details.
· Battery-backup method absolute encoder
· Wire-saving incremental encoder

*2 Items with ★ and speed - torque characteristics indicate values after temperature rise saturation when used with a standard servo amplifier. The values are the typical values.

*3 ☆ : Indicates a typical value when the winding temperature is 20°C . The values are the typical values.

*4 Values in parentheses are the output values for motors with brakes. With the optional oil seals or brakes, rated outputs of servo motors might be reduced to 80 to 95% of the values in the above table.

*5 Our standard servo amplifiers are CE and UL approved.

Speed-Torque Characteristics

Servo Motor Model No./Flange Size/Rated Output

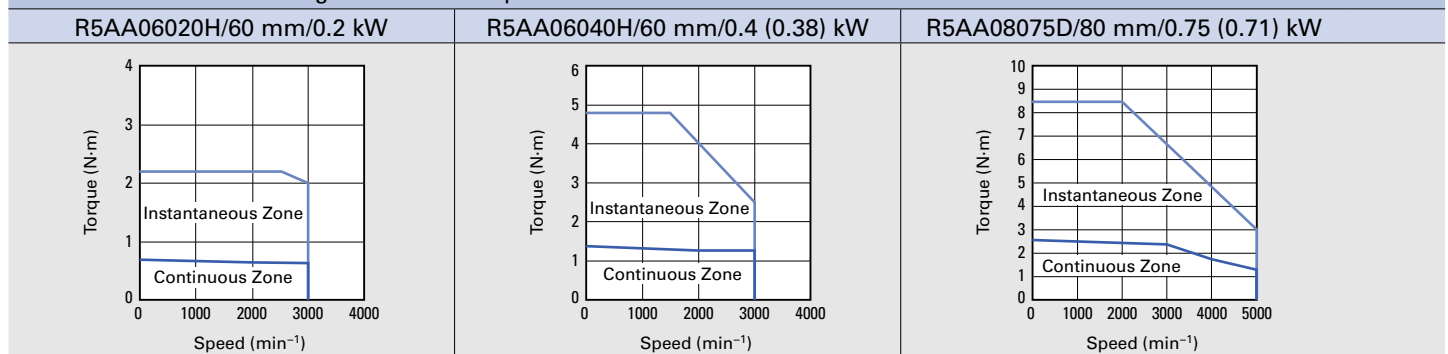

RS3A02□□《20 A》		RS3A03□□《30 A》		R 3E Model		Servo Amplifier Model No.
RS2A01□□《15 A》		RS2A03□□《30 A》		R ADVANCED		
RS1A01□□《15 A》		RS1A03□□《30 A》		R		
R5AA06020F 《60 mm sq.》	R5AA06040F 《60 mm sq.》	R5AA08075F 《80 mm sq.》		Servo Motor Model No. 《 》 indicates flange size		
			Unit	Symbol	Status	
0.2	0.4	0.75 (0.675) *4		kW	PR	★ Rated Output
3000	3000	3000		min ⁻¹	NR	★ Rated Speed
6000	6000	6000		min ⁻¹	N _{max}	★ Maximum Speed
0.637	1.27	2.39 (2.15) *4		N·m	TR	★ Rated Torque
0.686	1.37	2.55		N·m	TS	★ Continuous Stall Torque
2.2	4.8	7.5		N·m	TP	★ Peak Stall Torque
1.5	2.8	4.5		Arms	IR	★ Rated Armature Current
1.6	2.8	4.5		Arms	IS	★ Armature Stall Current
5.7	10.8	15.5		Arms	IP	★ Peak Armature Stall Current
0.476	0.525	0.607		N·m/Arms	K _T	☆ Torque Constant
16.1	17.3	18.9		mV/min ⁻¹	K _{Eφ}	☆ Voltage Constant for each Phase
2.7	1.36	0.51		Ω	R _φ	☆ Phase Resistance
20	39	35 (28) *4		kW/s	Q _R	★ Rated Power Rate
4.2	5.7	13		ms	te	☆ Electrical Time Constant
0.73	0.65	0.77		ms	tm	☆ Mechanical Time Constant (Not including Encoder)
0.198	0.414	1.65		×10 ⁻⁴ kg·m ² (GD ² /4)	J _M	Rotor Inertia
	0.0042*1			×10 ⁻⁴ kg·m ² (GD ² /4)	J _s	Absolute Encoder Inertia
0.99	1.5	2.8		kg	W _e	Servo Motor Mass *1
1.37 min.		2.55 min.		N·m	T _b	Brake Static Friction Torque
90 VDC/24 VDC±10%				V	V _b	Brake Rated Voltage
0.11/0.32		0.12/0.37		A	I _b	Brake Rated Current
0.060	0.060	0.25		×10 ⁻⁴ kg·m ² (GD ² /4)	J _b	Rotor Moment of Inertia (Brake)
0.39	0.39	0.89		kg	W	Brake Mass
0.6	1.0	1.6		kVA		Servo amplifier power supply capacity (rating)
Yes						CE and UL approved servo motors *5
IP65						Servo motor protection code
250 × 250 × 6 mm						Size of aluminum plates for heat radiation during measurement
p. 112						Page for motor dimensions

Servo Motor Operating Ambient Conditions

Operating temperature and humidity	Temp.: 0 to 40°C. Humidity: 90% max. (non-condensing)
Vibration resistance	24.5 m/s ²
Shock resistance	98 m/s ² , twice
Operation altitude	1000 m or lower above sea level
Installation location	Indoor (without direct sunlight) Location where no substance that gives adverse effects on the device and motor, such as corrosive gas, flammable gas, or dust exists

Servo Motor Model No./Flange Size/Rated Output

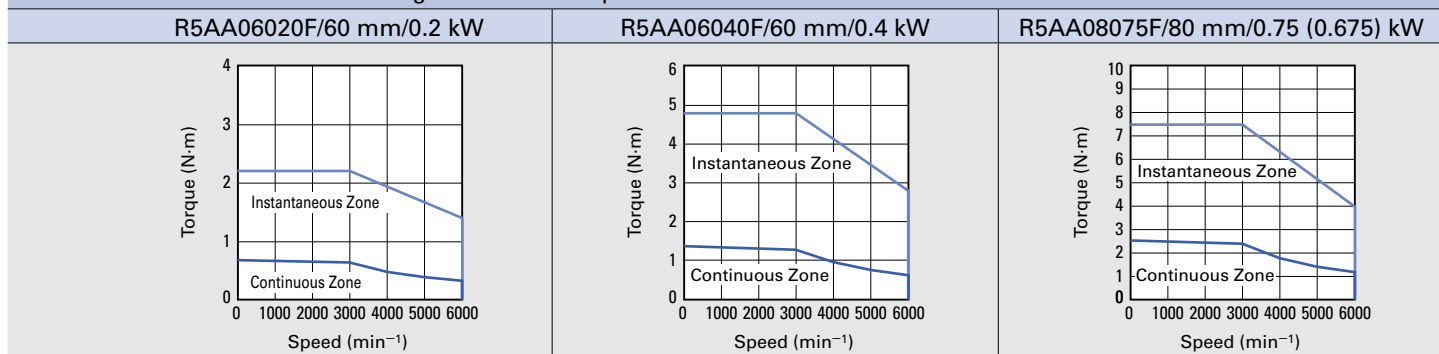

Dimensions [Unit: mm]

40 mm sq. to 100 mm sq.

R2 Servo Motor
R5 Servo Motor

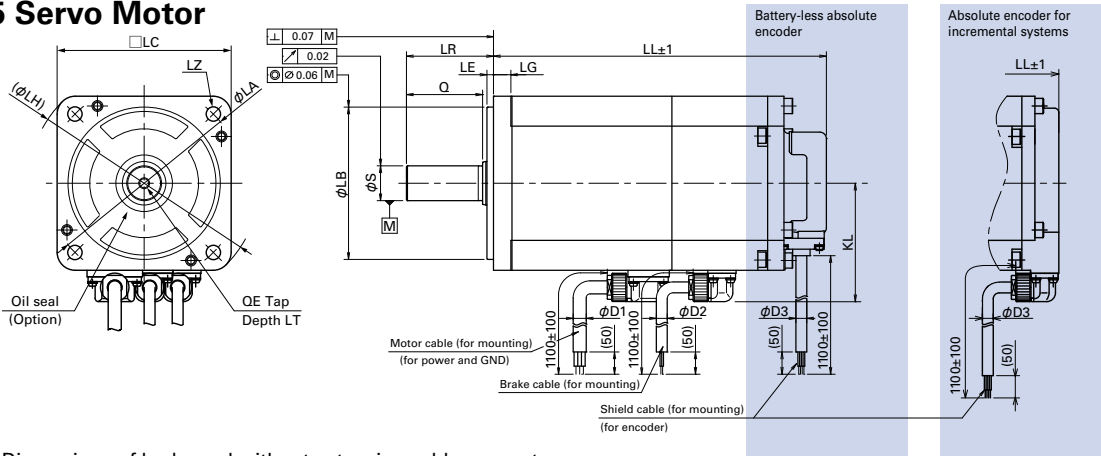

Dimensions of brake and without extension cable connector.

Model no.	Battery-less absolute encoder				Battery-backup method absolute encoder, Absolute encoder for incremental systems			
	W/out oil seal		With oil seal		W/out oil seal		With oil seal	
	W/out brake	With brake	W/out brake	With brake	W/out brake	With brake	W/out brake	With brake
	LL	LL	LL	LL	LL	LL	LL	LL
R2□A04003	62.5	98.5	67.5	103.5	51.5	87.5	56.5	92.5
R2□A04005	67.5	103.5	72.5	108.5	56.5	92.5	61.5	97.5
R2EA04008	83.0	119.0	88.0	124.0	72	108	77	113
R2AA04010								
R2□A06010	68.5	92.5	75.5	99.5	58.5	82.5	65.5	89.5
R2□A06020	79.5	107.5	86.5	114.5	69.5	97.5	76.5	104.5
R2AA06040	105.5	133.5	112.5	140.5	95.5	123.5	102.5	130.5
R2AA08020	76.3	112.0	83.3	119.0	66.3	102	73.3	109
R2AA08040	88.3	124.0	95.3	131.0	78.3	114	85.3	121
R2AA08075	117.3	153.0	124.3	150.2	107.3	143	114.3	150
R2AAB8075	123.1	149.0	123.1	149.0	114.3	140.2	114.3	140.2
R2AAB8100*	145.8	171.8	145.8	171.8	137	163	137	163
R2AA10075	117.1	134.6	117.1	134.6	111.3	128.8	111.3	128.8
R2AA10100	134.1	151.6	134.1	151.6	128.3	145.8	128.3	145.8
R5AA06020	79.5	107.5	86.5	114.5	72.5	100.5	79.5	107.5
R5AA06040	105.5	133.5	112.5	140.5	98.5	126.5	105.5	133.5
R5AA08075	117.3	153.0	124.3	150.2	110.3	146	117.3	153

*The outline drawing of the R2AAB8100 varies for Philippine products. See p. 113.

Model no.	LG	KL	LA	LB	LE	LH	LC	LZ	LR	S	Q	QE	LT	D1	D2	D3
R2□A04003	5	35.4	46	30 ⁰ _{-0.021}	2.5	56	40	2-φ4.5	25	0 ⁰ _{6 -0.008}	20	—	—	6	5	5
R2□A04005										0 ⁰ _{8 -0.009}						
R2EA04008										0 ⁰ _{8 -0.009}						
R2AA04010										0 ⁰ _{8 -0.009}						
R2□A06010	6	44.6	70	50 ⁰ _{-0.025}	3	82	60	4-φ5.5	25	0 ⁰ _{8 -0.009}	25	M5	12	6	5	5
R2□A06020										0 ⁰ _{14 -0.011}						
R2AA06040										0 ⁰ _{14 -0.011}						
R2AA08020										0 ⁰ _{14 -0.011}						
R2AA08040	8	54.4	90	70 ⁰ _{-0.030}	3	108	80	4-φ6.6	30	0 ⁰ _{16 -0.011}	35	M5	12	6	5	5
R2AA08075										0 ⁰ _{16 -0.011}						
R2AAB8075										0 ⁰ _{16 -0.011}						
R2AAB8100*										0 ⁰ _{16 -0.011}						
R2AA10075	10	66.8	115	95 ⁰ _{-0.035}	3	130	100	4-φ9	45	0 ⁰ _{22 -0.013}	40	M6	20	6	5	5
R2AA10100										0 ⁰ _{22 -0.013}						
R5AA06020										0 ⁰ _{14 -0.011}						
R5AA06040										0 ⁰ _{14 -0.011}						
R5AA08075	8	54.4	90	70 ⁰ _{-0.030}	3	108	80	4-φ6.6	40	0 ⁰ _{16 -0.011}	35	M5	12	6	5	5
R5AA08075										0 ⁰ _{16 -0.011}						

The cable length of the motor with extension cable connector is 200±30 mm. The connector is attached to the end of the cable. See p. 138

Dimensions [Unit: mm]

86 mm sq. R2 Servo Motor Series Made in The Philippines

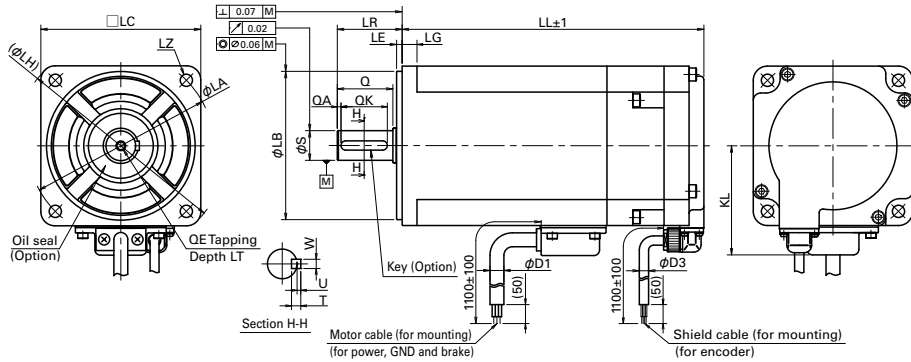

Dimensions of the battery-backup method absolute encoder and brake.

Model no.	Battery-backup method absolute encoder, Absolute encoder for incremental system				LG	KL	LA	LB	LE	LH	LC	LZ	LR
	W/out oil seal		With oil seal										
	W/out brake	With brake	W/out brake	With brake									
R2AAB8100	139	163	139	163	8	58.8	100	0 80 -0.030	3	115.5	86	4-φ 6.6	35

Model no.	S	Q	QE	LT	D1	D2	D3	QA	QK	W	T	U
R2AAB8100	0 16 -0.011	30	M5	12	7.5	-	5	2	25	0 5 -0.030	5	0 2 -0.2

130 mm sq. R2 Servo Motor 0.55 to 1.8 kW

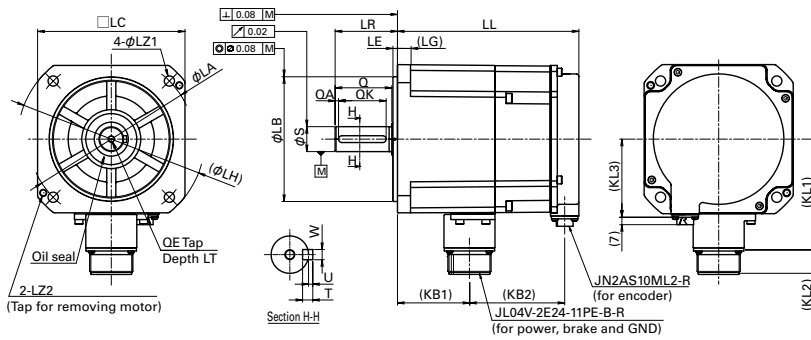

Dimensions of the battery-less absolute encoder with brake

Model no.	Battery-less absolute encoder, Battery-backup method absolute encoder, Absolute encoder for incremental systems											LE	LH	LC	LZ1	LZ2	LR
	W/out brake			With brake			LG	KL1	KL2	LA	LB						
	LL	KB2	KL3	LL	KB2	KL3											
R2AA13050	103			139.5	81												
R2AA13120	120.5	44	69	160	84	69	12	98	21	145	0 110 -0.035	4	165	130	9	M6	55
R2AA13180	138			179	86												

Model no.	S	Q	QA	QK	W	T	U	KB1	QE	LT
R2AA13050								46		
R2AA13120	0 22 -0.013	50	3	42	0 6 -0.030	6	2.5	64	M6	20
R2AA13180								81		

Dimensions [Unit: mm]

130 mm sq. R2 Servo Motor 2 kW Made in Japan

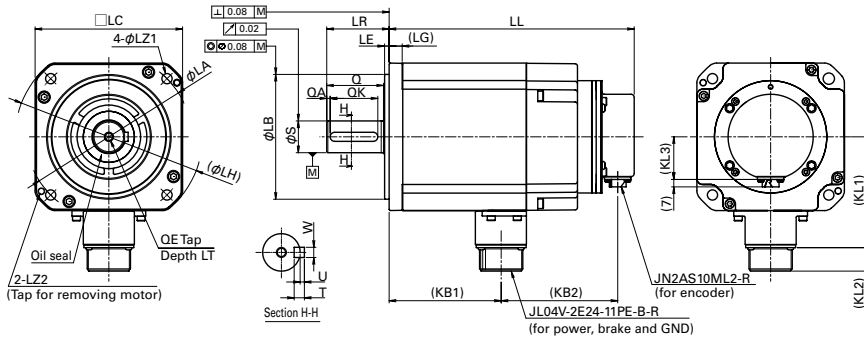

Dimensions of the battery-less absolute encoder with brake

Model no.	Battery-less absolute encoder, Absolute encoder for incremental systems											LE	LH	LC	LZ1	LZ2	LR
	W/out brake			With brake					LA	LB							
R2AA13200	LL	KB2	KL3	LL	KB2	KL3	LG	KL1	KL2	LA	LB	4	165	130	9	M6	55
	171	57	38	216	103	38	12	98	21	145	110 ⁰ _{-0.035}						
Model no.	S	Q	QA	QK	W	T	U	KB1	QE	LT							
R2AA13200	28 ⁰ _{-0.013}	50	3	42	8 ⁰ _{-0.036}	7	3	99	M8	25							

130 mm sq. R2 Servo Motor Series 2 kW Made in The Philippines

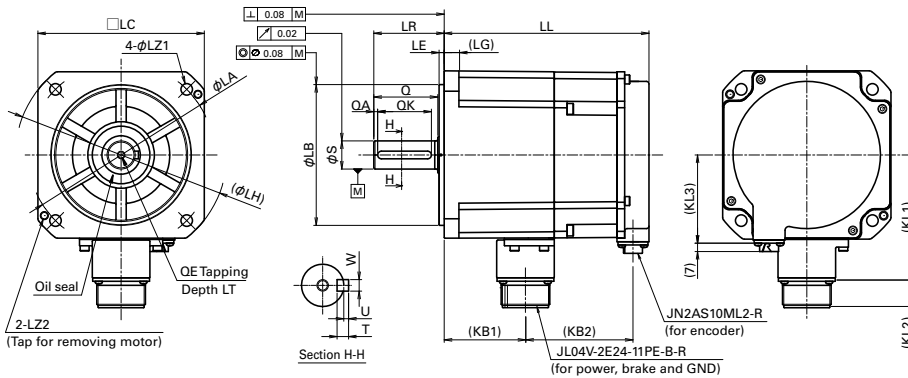

Dimensions of the battery-backup method absolute encoder and brake.

Model no.	Battery-backup method absolute encoder, Absolute encoder for incremental system											LE	LH	LC	LZ1	LZ2	LR	
	W/out brake			With brake					LA	LB								
R2AA13200	LL	KB2	KL3	LL	KB2	KL3	LG	KL1	KL2	KL3	LA	LB	4	165	130	9	M6	55
	160	48	38	201	90	38	12	98	21	69	145	110 ⁰ _{-0.035}						
Model no.	S	Q	QA	QK	W	T	U	KB1	QE	LT								
R2AA13200	28 ⁰ _{-0.013}	50	3	42	8 ⁰ _{-0.036}	7	3	99	M8	25								

Dimensions [Unit: mm]

180 mm sq. R2 Servo Motor 3.5 to 7.5 kW

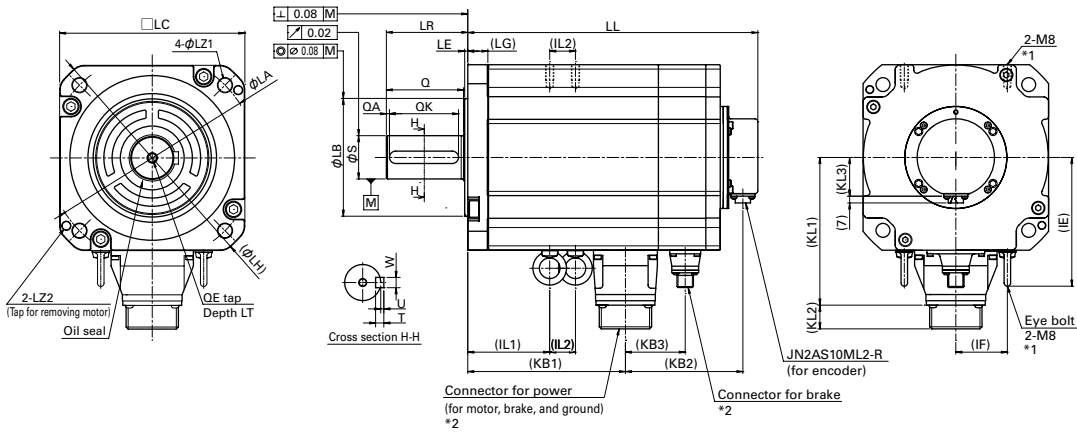

Dimensions of the battery-less absolute encoder with brake

Model no.	Battery-less absolute encoder, Absolute encoder for incremental systems																S	Q			
	W/out brake				With brake				LG	KL1	KL2	LA	LB	LE	LH	LC			LZ1	LZ2	LR
	LL	KB2	KB3	KL3	LL	KB2	KB3	KL3													
R2AA18350	155	48	—	38	205	98	—	38	16	123	21	200	114.3 ⁰ -0.035	3	230	180	13.5	M8	65	35 ⁰ -0.016	60
R2AA18450	172				222				19	144	22										
R2AA18550	228	59	—	38	274	107	64	123	50	63	41	86	JL04V-2E32-17PE-B-R	JL04V-2E10SL-3PE-B-R	75						
R2AA18750	273				329	117	74									19	144	22			

Model no.	QA	QK	W	T	U	KB1	QE	LT	IE	IF	IL1	IL2	Connector model no. for power	Connector model no. for brake
R2AA18350	3	50	10 ⁰ -0.036	8	3	92	M8	25	123 ^{*1}	50 ^{*1}	47 ^{*1}	20 ^{*1}	JL04V-2E24-11PE-B-R	— *2
R2AA18450						109			57	20				
R2AA18550		67	12 ⁰ -0.043		153	M10	123	50	63	86	JL04V-2E32-17PE-B-R	JL04V-2E10SL-3PE-B-R		
R2AA18750					198									

*1 Eye bolts are not provided to motors without R2AA18350 brake.
*2 The brake wire is commonly used by the connector for power.

180 mm sq. R2 Servo Motor 11 kW

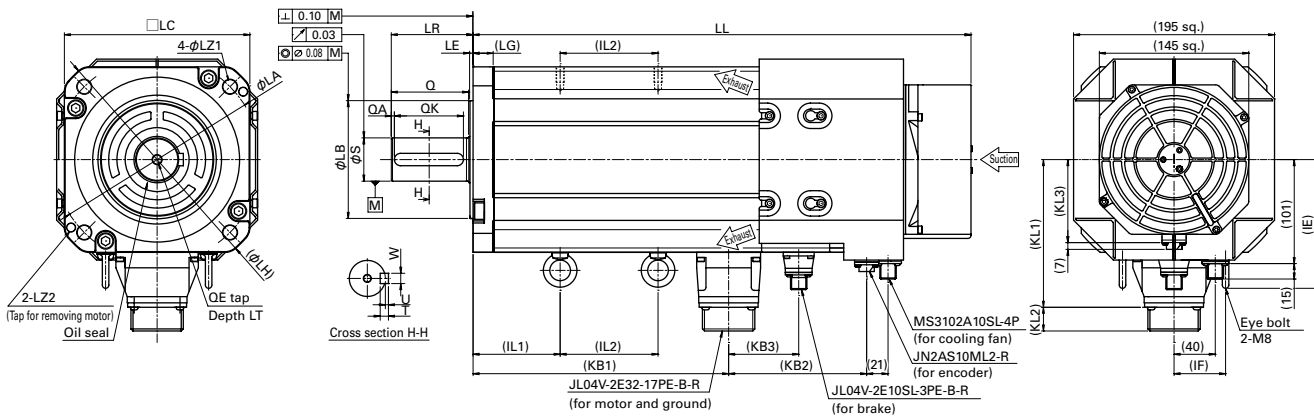

Dimensions of the battery-less absolute encoder with brake

Model no.	Battery-less absolute encoder, Absolute encoder for incremental systems																S	Q			
	W/out brake				With brake				LG	KL1	KL2	LA	LB	LE	LH	LC			LZ1	LZ2	LR
	LL	KB2	KB3	KL3	LL	KB2	KB3	KL3													
R2AA1811K	395	60	—	81	467	133	90	81	19	143	23	200	114.3 ⁰ -0.035	3	230	180	13.5	M8	79		

Model no.	S	Q	QA	QK	W	T	U	KB1	QE	LT	IE	IF	IL1	IL2
R2AA1811K	42 ⁰ -0.016	75	3	67	12 ⁰ -0.043	8	3	220	M10	25	123	50	63	108

Dimensions [Unit: mm]

220 mm sq. R2 Servo Motor 5 kW

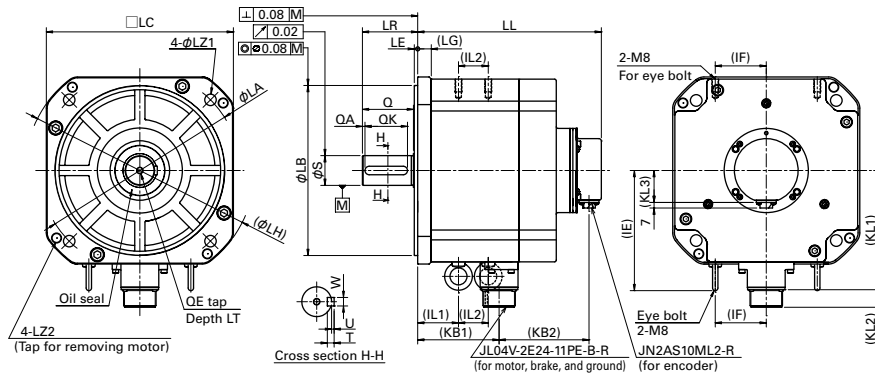

Dimensions of the battery-less absolute encoder with brake

Model no.	Battery-less absolute encoder, Absolute encoder for incremental systems																		
	W/out brake						With brake												
	LL	KB2	KL3	LL	KB2	KL3	LG	KL1	KL2	KL3	LA	LB	LE	LH	LC	LZ1	LZ2	LR	
R2AA22500	163	52	38	216	106	38	16	142	21	38	235	200 ⁰ -0.046	4	270					
Model no.	LC	LZ1	LZ2	LR	S	Q	QA	QK	W	T	U	KB1	QE	LT	IE	IF	IL1	IL2	
R2AA22500	220	13.5	M12	65	35 ⁰ -0.016	60	3	50	10 ⁰ -0.036	8	3	96	M8	25	142	60	48	35	

R2 Servo Motor 7 to 15 kW

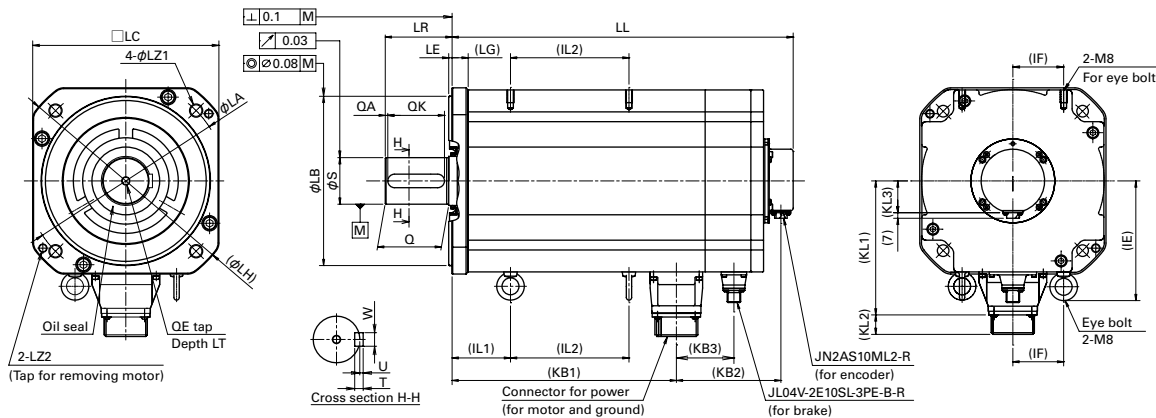

Dimensions of the battery-less absolute encoder with brake

Model no.	Battery-less absolute encoder, Absolute encoder for incremental systems																		
	W/out brake						With brake												
	LL	KB2	KB3	KL3	LL	KB2	KB3	KL3	LG	KL1	KL2	LA	LB	LE	LH	LC	LZ1	LZ2	LR
R2AA22700	265	54		38	325	114	57			141	21								
R2AA2211K	304			38	364		38	19		162	22	235	200 ⁰ -0.046	4	270	220	13.5	M10	79
R2AA2215K	343	63			403	123	66												
Model no.	QA	QK	W	T	U	KB1	QE	LT	IE	IF	IL1	IL2	Connector model no. for power						
R2AA22700						196						62	JL04V-2E24-11PE-B-R						
R2AA2211K	3	67	16 ⁰ -0.043	10	4	226	M10	25	142	60	69	101	JL04V-2E32-17PE-B-R						
R2AA2215K						265						140							

Dimensions [Unit: mm]

220 mm sq. R2 Servo Motor 20 kW

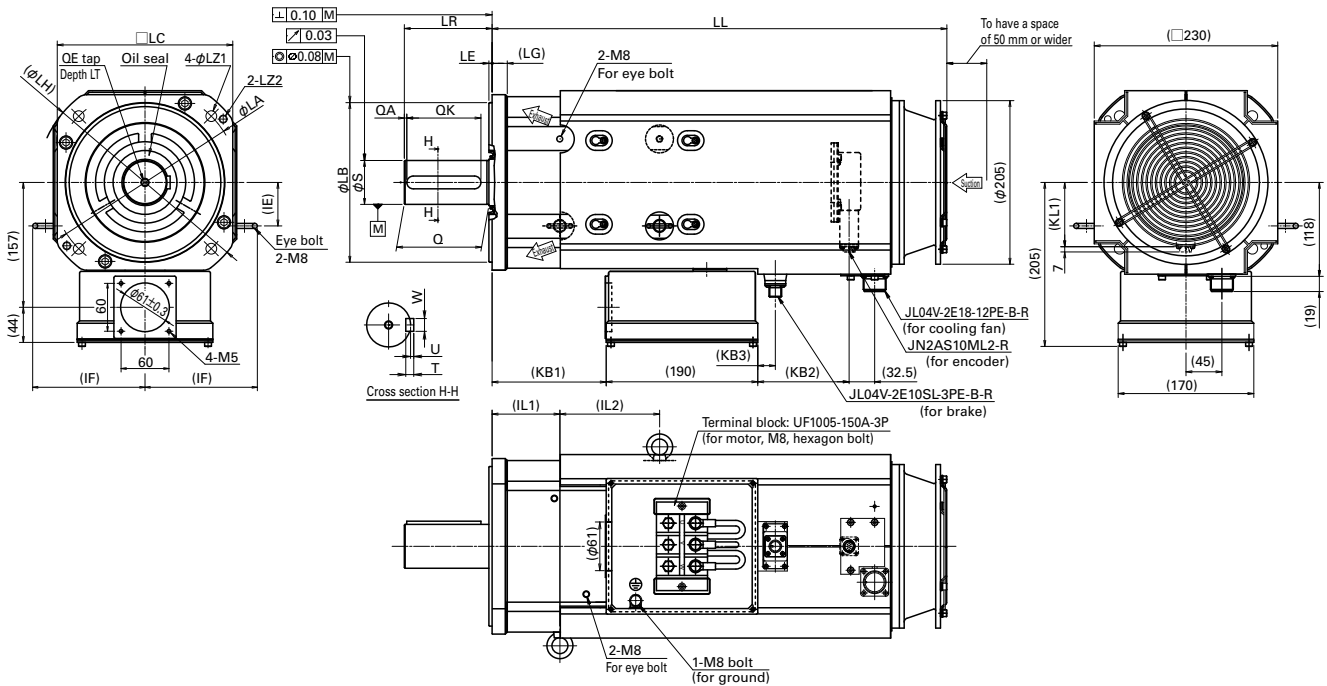

Dimensions of the battery-less absolute encoder with brake

Model no.	Battery-less absolute encoder, Absolute encoder for incremental systems																			
	W/out brake				With brake															
	LL	KB2	KB3	KL1	LL	KB2	KB3	KL1	LG	LA	LB	LE	LH	LC	LZ1	LZ2	LR	S	Q	
R2AA2220K	466	10	—	81	570	114	22	81	19	235	0 200 -0.046	4	270	220	13.5	M10	110	0 55 -0.019	106	

Model no.	QA	QK	W	T	U	KB1	QE	LT	IE	IF	IL1	IL2
R2AA2220K	3	93	0 16 -0.043	10	4	143	M10	25	55	141	85	125

275 mm sq. R2 Servo Motor 30 kW

Model no.: R2AA2830K

Dimensions without brake

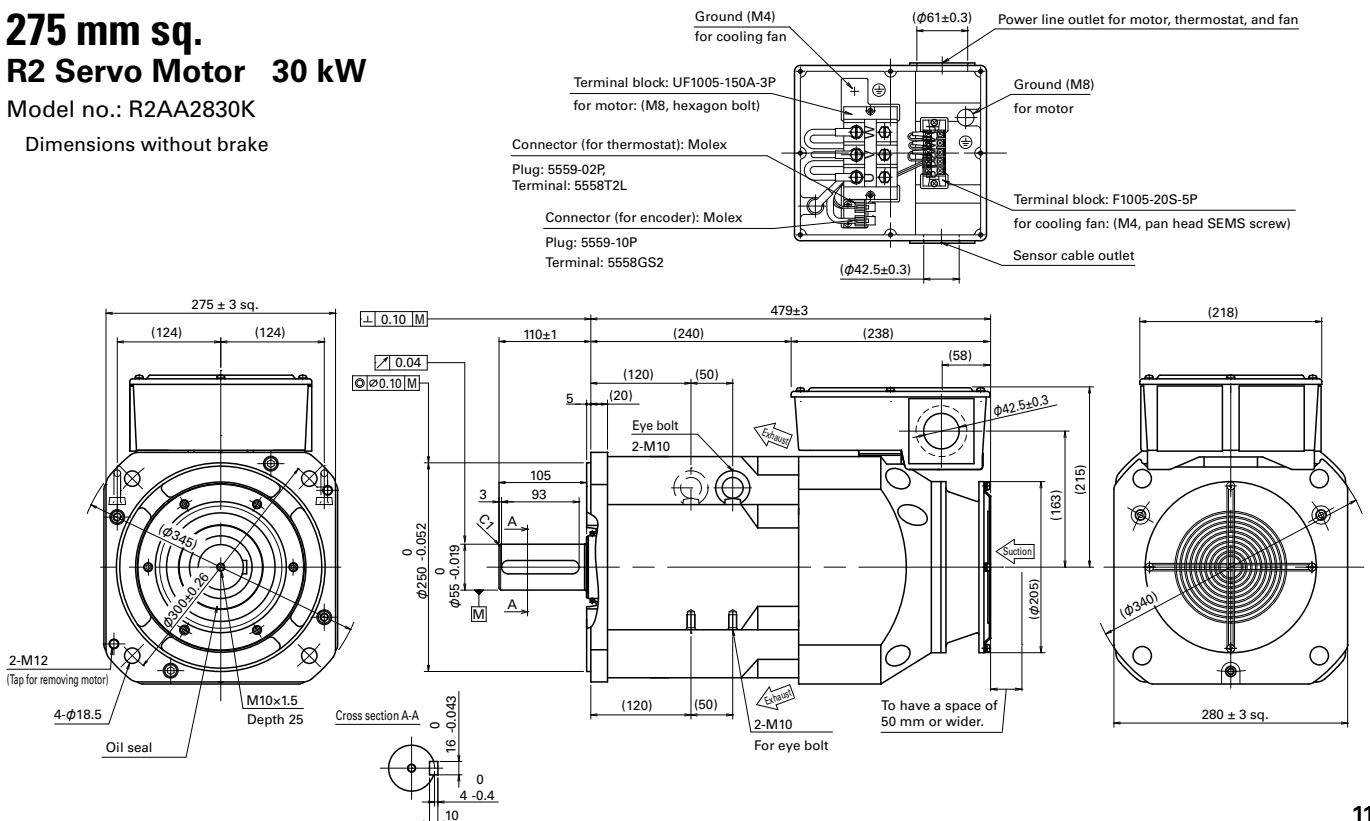

Servo Motors
Rotary Motor

Dimensions [Unit: mm]

180 mm sq. R1 Servo Motor 5.5 to 15 kW

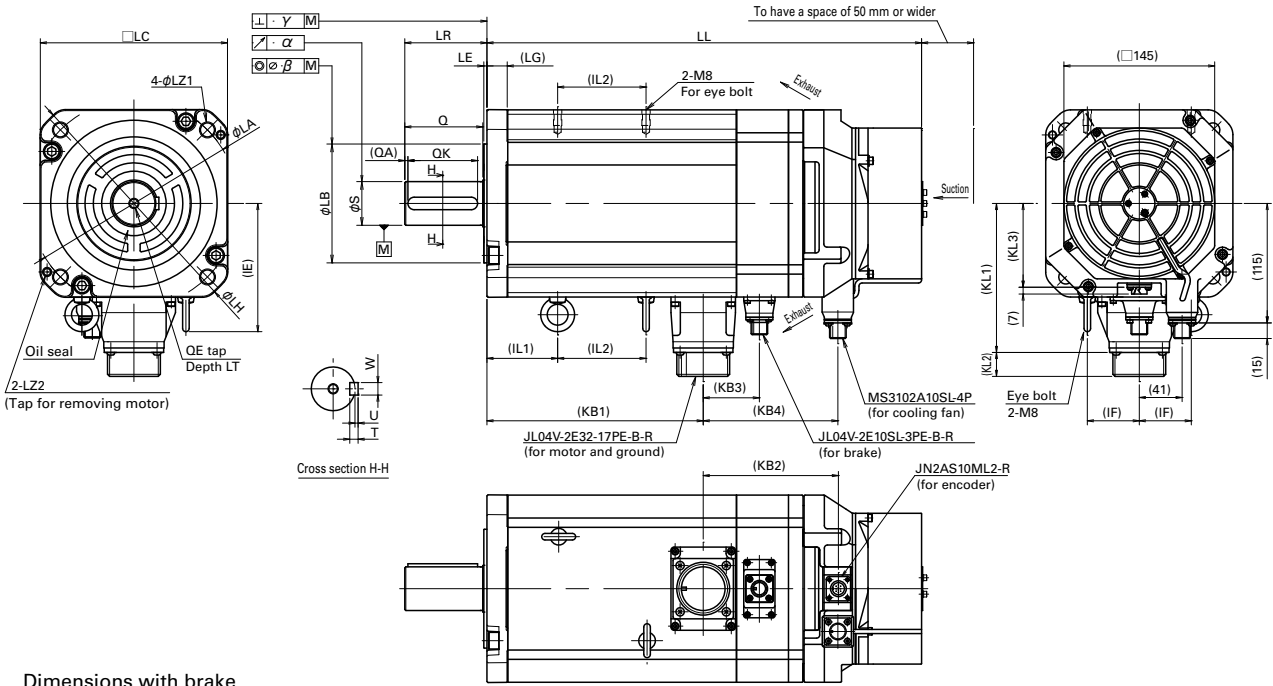

Dimensions with brake

Model no.	Battery-less absolute encoder, Absolute encoder for incremental systems											QE	LT	IE	IF	IL1	IL2			
	W/out brake					With brake														
	LL	KB2	KB3	KB4	KL3	LL	KB2	KB3	KB4	KL3	LG	KL1	KL2	LA	LB	LE	LH	LC	LZ1	LZ2
R1AA18550	333	80.5	-	79.5	81	383	130.5	54	129.5	81	19.5	143	23	200	0 114.3 -0.035	3	230	180	13.5	M8
R1AA18750	368					418	130.5	54	129.5		19.5									
R1AA1811K	438					517	149.0	79	158.0		19.5									
R1AA1815K	516					628	182.0	110	191.0		19.0									

Model no.	LR	S	Q	QA	QK	W	T	U	KB1	α	β	γ	QE	LT	IE	IF	IL1	IL2	
R1AA18550	79	0	75	3	67	12 -0.043	8	3	173	0.02	0.08	0.08	M10	25	124	50	68	85	
R1AA18750		42 -0.016							0										208
R1AA1811K		0							278										
R1AA1815K		55 -0.019							16 -0.043										10

220 mm sq. R1 Servo Motor 21 kW

Model no.: R1AA2220KV

Dimensions without brake

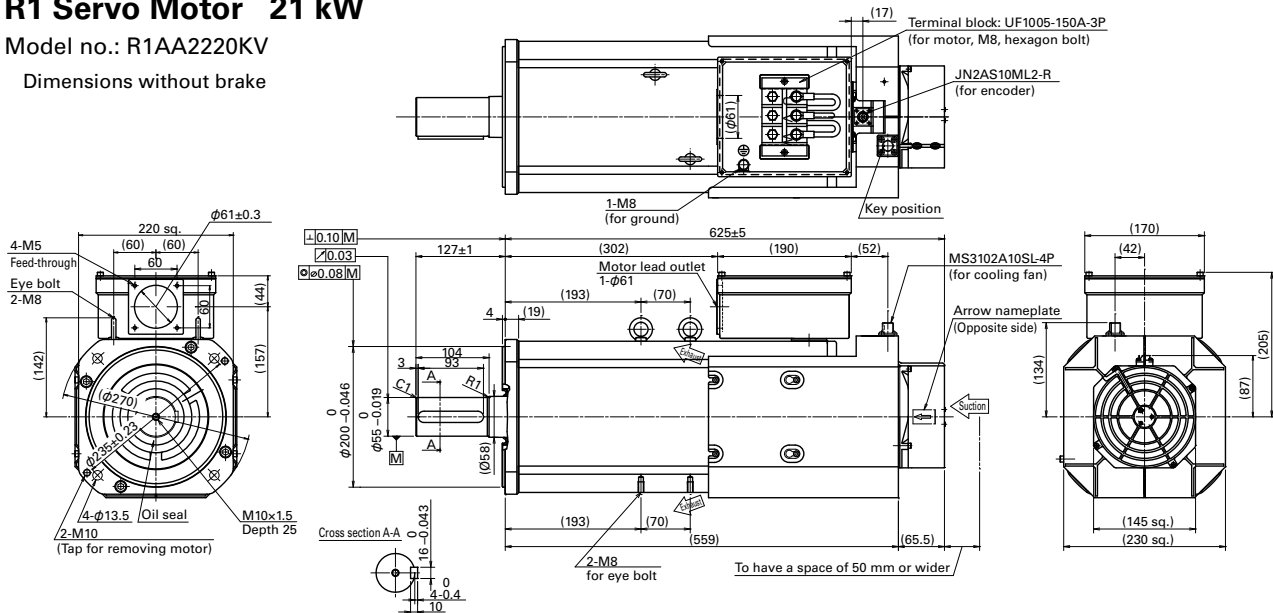

Options

Setup Software

This software allows you to set servo system parameters from a PC.
It also allows you to easily start up and run tests for the servo system.
The software can be downloaded from Product Information on our website.
URL:<http://www.sanyodenki.com>

R 3E Model R ADVANCED

■ Setup software title:

SANMOTION MOTOR SETUP SOFTWARE

■ Main functions

- Parameter settings (settings by group, settings by function)
- Diagnosis (alarm display, warning display, alarm cancellation)
- Test run execution (speed JOG, positioning operation, motor home position search, serial encoder clearance)
- Servo tuning (notch filter tuning, FF vibration control frequency tuning)
- Various measurement functions (operating waveform display, machinery frequency response measurement)
- R 3E Model: Use a USB communication cable (mini-B socket) to connect the USB port on the PC and the servo amplifier.
- R ADVANCED MODEL: Use a dedicated cable (AL-00689703-01) to connect the RS-232C terminal on the PC and the servo amplifier.

■ Supported OS

Windows XP (SP3 or newer) / Vista / 7 / 8

* See our website for details on supported OS versions.

R

■ Setup software title:

SANMOTION R-SETUP SOFTWARE

■ Main functions

- Parameter settings (settings by group, settings by function)
- Diagnosis (alarm display, warning display, alarm cancellation)
- Test run execution (speed JOG, pulse feed JOG, serial encoder clearance)
- Servo tuning (notch filter tuning, FF vibration control frequency tuning)
- Various measurement functions (operating waveform display, machinery frequency response measurement)
- Use a dedicated cable (AL-00490833-01) to connect the RS-232C terminal on the PC and the servo amplifier.

■ Supported OS

Windows XP (SP3 or newer) / Vista / 7 / 8

* See our website for details on supported OS versions.

Examples of setting screens and functions with SANMOTION R 3E Model

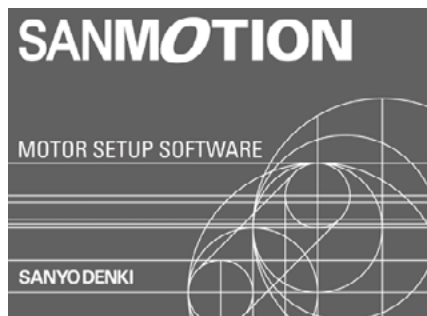

Start-up screen

Main screen

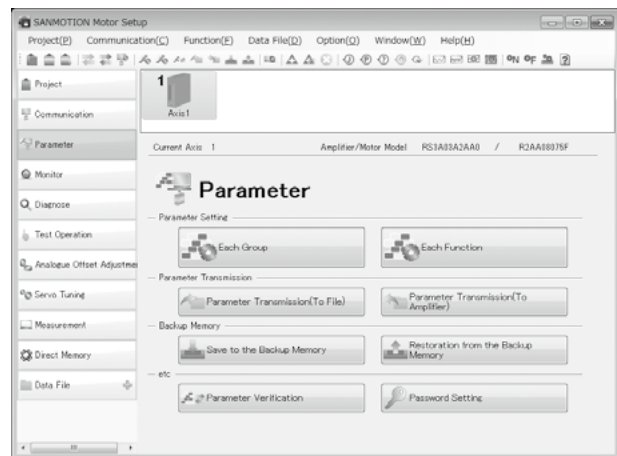

Parameter Setting screen

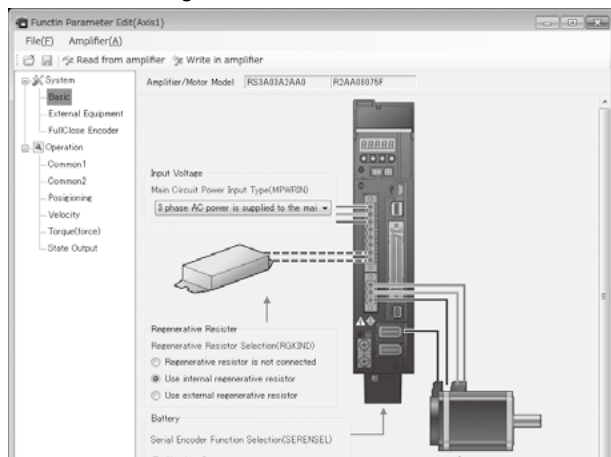

Function Parameter Edit

Minimum required parameter setting by function can be done.

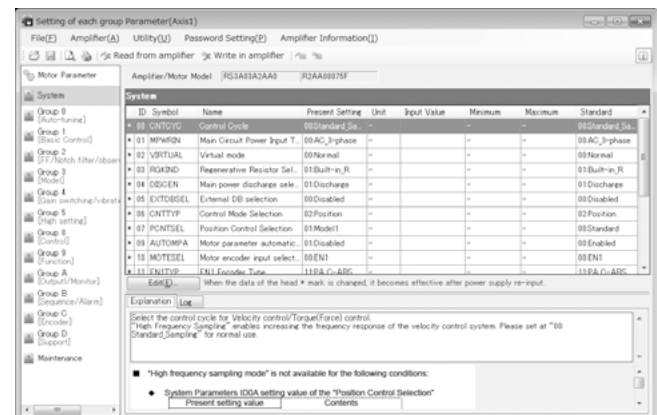

Parameter setting for each group

Parameters can be set, saved, and more.

Diagnosis screen

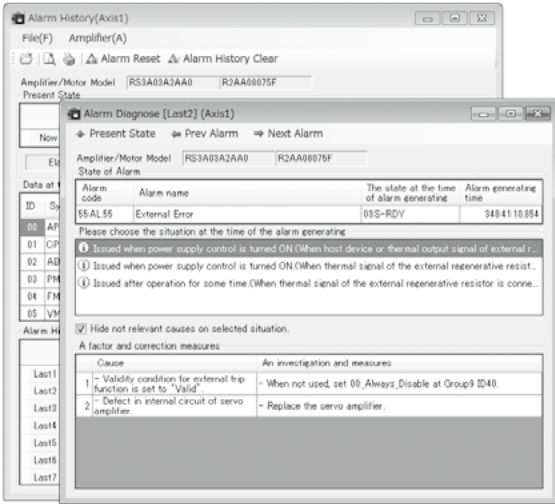

The current and previous 15 alarm occurrences can be checked. (last seven alarms for R ADVANCED MODEL)
 Causes and corrective actions can be checked based on alarm status.

Test run



Simple test run of servo motor by issuing velocity commands and position commands from a PC. (Position JOG in operation shown in screen)

Servo adjustment assist

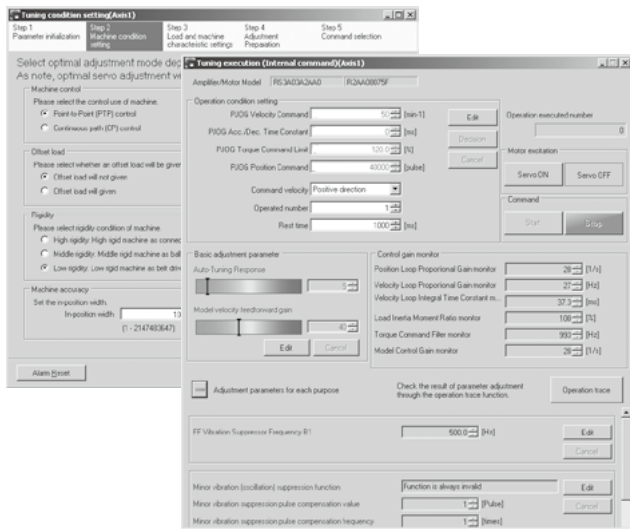

By setting the mechanical conditions, easy servo adjustment is available with the optimal tuning mode.

Measurement

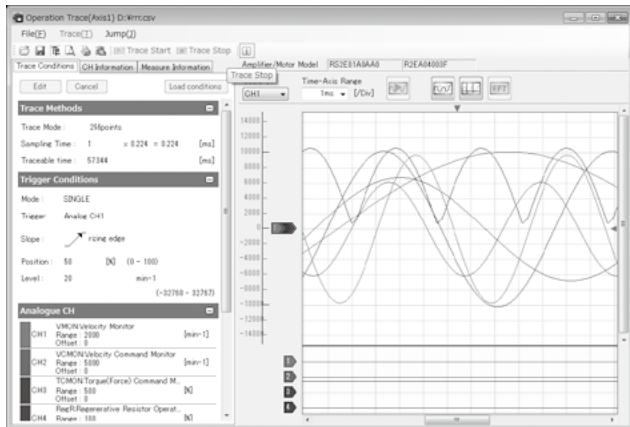

Operation Trace
 Graphically displays servo motor's speed, torque and internal status.

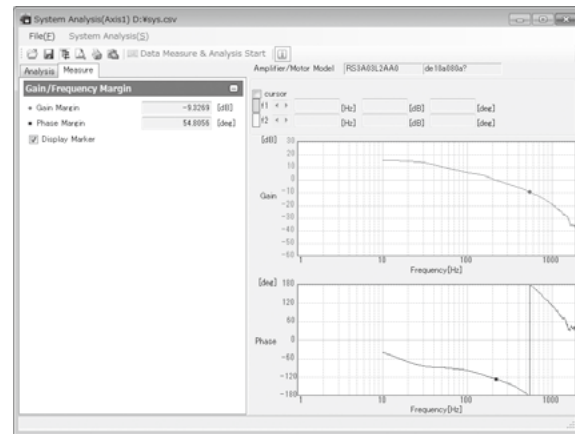

System Analysis
 Analyzes servo system frequency characteristics.

Connector to Connect Servo Amplifier

■ For Analog/Pulse input type

R 3E Model

10 to 50 A

Individual connectors

Connector no.	Description	Model no.	Manufacturer model no.	Manufacturer
CN1	To connect host device	AL-00385594	10150-3000PE, 10350-52A0-008	3M Japan Limited
EN1, EN2	To connect encoder	AL-00632607	36210-0100PL, 36310-3200-008	
CNA*1	For input power supply and regenerative resistor connections	AL-00686902-01	MSTBT2.5/8-STF-5.08LUB	Phoenix Contact.K.K
CNB	To connect to servo motor	AL-Y0004079-01	MSTBT2.5/3-STF-5.08	
CN4*2	To connect safety device (for short circuits)	AL-00718251-01	2040978-1	Tyco Electronics Japan G.K.
CN4	To connect safety device (for wiring)	AL-00718252-01	2013595-3	

*1: Amplifiers with built-in regenerative resistor are equipped with a CNA connector.

*2: When CN4 is not wired, be sure to insert a safety device connector (for short circuits) to CN4 on the servo amplifier.

Connector sets (no safe torque off function)

Servo Amplifier model no.	RS3□□□A0□L0 RS3□□□A8□L0	RS3□□□A0□A0 RS3□□□A8□A0	RS3□□□A2□L0 RS3□□□AA□L0	RS3□□□A2□A0 RS3□□□AA□A0	RS3□□□A0□□0 RS3□□□A8□□0	RS3□□□A□□L0
Built-in regenerative resistor	No	Yes	No	Yes	No/Yes	No
Connector set model no.	AL-00723282	AL-00723284	AL-00723286	AL-00723288	AL-00723290	AL-00696037
Connectors included in the set	CN1: To connect host device	Yes	Yes	Yes	Yes	No
	EN1: To connect encoder	Yes	Yes	Yes	Yes	No
	EN2: To connect encoder	No	No	Yes	Yes	No
	CNA: To connect input power supply, regenerative resistor	Yes	No	Yes	No	No
	CNB: For servo motor connection	Yes	Yes	Yes	Yes	No
	CN4: To connect safety device (for short circuits)	No	No	No	No	No
	CN4: To connect safety device (for wiring)	No	No	No	No	No
Remarks	For fully-closed control systems					

Connector sets (with safe torque off function)

Servo Amplifier model no.	RS3□□□A0□L2(4) RS3□□□A8□L2(4)	RS3□□□A0□A2(4) RS3□□□A8□A2(4)	RS3□□□A2□L2(4) RS3□□□AA□L2(4)	RS3□□□A2□A2(4) RS3□□□AA□A2(4)	RS3□□□A0□□2(4) RS3□□□A8□□2(4)
Built-in regenerative resistor	No	Yes	No	Yes	No/Yes
Connector set model no.	AL-00723155	AL-00723156	AL-00723157	AL-00723158	AL-00723159
Connectors included in the set	CN1: To connect host device	Yes	Yes	Yes	Yes
	EN1: To connect encoder	Yes	Yes	Yes	Yes
	EN2: To connect encoder	No	No	Yes	Yes
	CNA: For input power supply, regenerative resistor connection	Yes	No	Yes	No
	CNB: For servo motor connection	Yes	Yes	Yes	Yes
	CN4: To connect safety device (for short circuits)	No	No	No	No
	CN4: To connect safety device (for wiring)	Yes	Yes	Yes	Yes
Remarks	For fully-closed control systems				

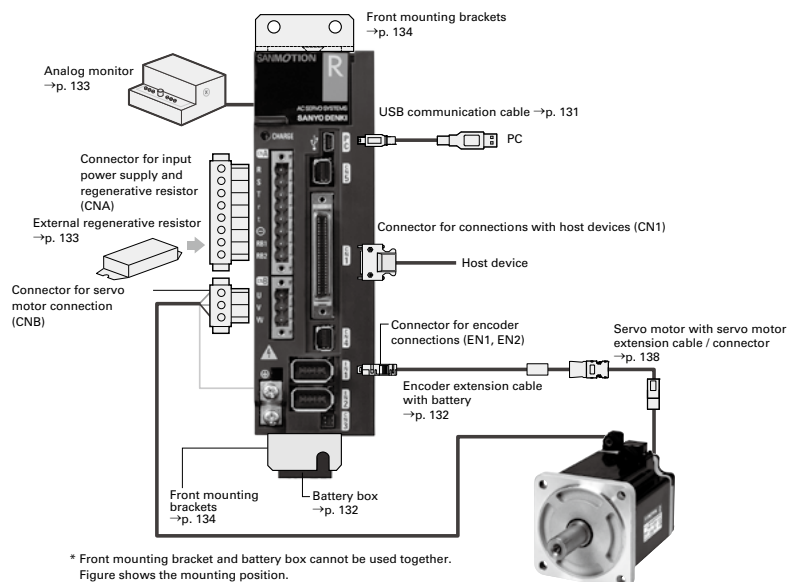

Connector to Connect Servo Amplifier

■ For Analog/Pulse input type 100, 150, 300 A

R 3E Model

Individual connectors

Connector no.	Description	Model no.	Manufacturer model no.	Manufacturer
CN1	To connect host device	AL-00385594	10150-3000PE, 10350-52A0-008	3M Japan Limited
EN1,EN2	To connect encoder	AL-00632607	36210-0100PL, 36310-3200-008	
CNA	To input control circuit power supply	AL-Y0005159-01	MSTBT2.5/2-STF-5.08	Phoenix Contact.K.K
CN4*	To connect safety device (for short circuits)	AL-00718251-01	2040978-1	Tyco Electronics Japan G.K.
CN4	To connect safety device (for wiring)	AL-00718252-01	2013595-3	

* When CN4 is not wired, be sure to insert a safety device connector (for short circuits) to CN4 on the servo amplifier.

Connector sets (no safe torque off function)

Servo Amplifier model no.	RS3□□□A0□□0 RS3□□□A8□□0	RS3□□□A2□□0 RS3□□□AA□□0	RS3□□□A0□□0 RS3□□□A8□□0
Built-in regenerative resistor	No	No	No
Connector set model no.	AL-00751448	AL-00751450	AL-00723290
Connectors included in the set	CN1: To connect host device	Yes	Yes
	EN1: To connect encoder	Yes	Yes
	EN2: To connect encoder	No	Yes
	CNA: To input control circuit power supply	Yes	Yes
	CN4: To connect safety device (for short circuits)	No	No
	CN4: To connect safety device (for wiring)	No	No
Remarks		For fully-closed control systems	

Connector sets (with safe torque off function)

Servo Amplifier model no.	RS3□□□A0□□2(4) RS3□□□A8□□2(4)	RS3□□□A2□□2(4) RS3□□□AA□□2(4)	RS3□□□A0□□2(4) RS3□□□A8□□2(4)
Built-in regenerative resistor	No	No	No
Connector set model no.	AL-00751452	AL-00751454	AL-00723159
Connectors included in the set	CN1: To connect host device	Yes	Yes
	EN1: To connect encoder	Yes	Yes
	EN2: To connect encoder	No	Yes
	CNA: To input control circuit power supply	Yes	Yes
	CN4: To connect safety device (for short circuits)	No	No
	CN4: To connect safety device (for wiring)	Yes	Yes
Remarks		For fully-closed control systems	

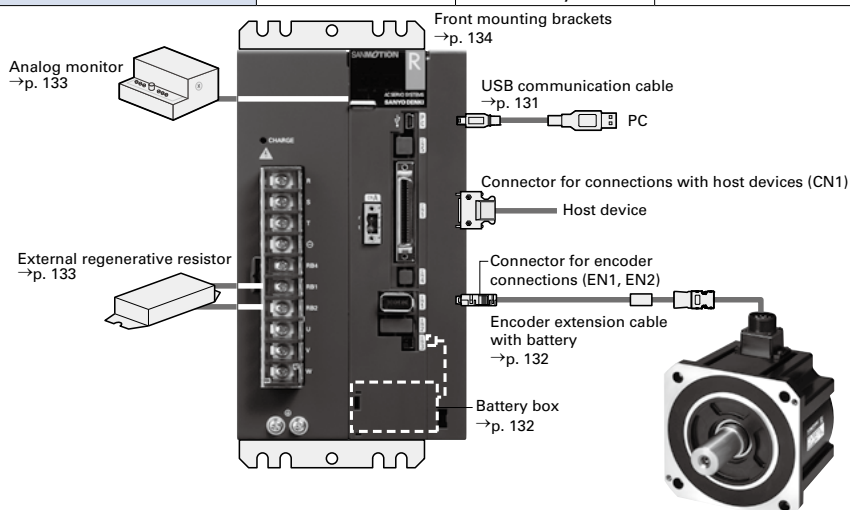

Options

Connector to Connect Servo Amplifier

■ For Analog/Pulse input type

R 3E Model

600 A

Individual connectors

Connector no.	Description	Model no.	Manufacturer model no.	Manufacturer
CN9	To connect between units (single item)	AL-00608710	10114-3000PE, 10314-52A0-008	3M Japan Limited
CN1	To connect host device	AL-00385594	10150-3000PE, 10350-52A0-008	
EN1, EN2	To connect encoder	AL-00632607	36210-0100PL, 36310-3200-008	
CNA	To input control circuit power supply	AL-Y0005159-01	MSTBT2.5/2-STF-5.08	Phoenix Contact.K.K
CNB	For dynamic brake signal	AL-Y0004079-01	MSTBT2.5/3-STF-5.08	
CN8	For external alarm signal	AL-Y0011185-01	FMC0,5/4-ST-2.54	
CN4*	To connect safety device (for short circuits)	AL-00718251-01	2040978-1	Tyco Electronics Japan G.K.
CN4	To connect safety device (for wiring)	AL-00718252-01	2013595-3	

* When CN4 is not wired, be sure to insert a safety device connector (for short circuits) to CN4 on the servo amplifier.

Connector sets (no safe torque off function)

Connector set model no.		AL-00892848	AL-00892850	AL-00723290	AL-00892854
Connectors included in the set	CN1: To connect host device	Yes	Yes	Yes	No
	EN1: To connect encoder	Yes	Yes	Yes	No
	EN2: To connect encoder	No	Yes	No	No
	CNA: To input control circuit power supply	Yes	Yes	No	Yes
	CNB: For dynamic brake signal	No	No	No	Yes
	CN8: For external alarm signal	Yes	Yes	No	No
Remarks			For fully-closed control systems		

Connector sets (with safe torque off function)

Connector set model no.		AL-00892856	AL-00892858	AL-00723159	AL-00892852
Connectors included in the set	CN1: To connect host device	Yes	Yes	Yes	No
	EN1: To connect encoder	Yes	Yes	Yes	No
	EN2: To connect encoder	No	Yes	No	No
	CNA: To input control circuit power supply	Yes	Yes	No	Yes
	CNB: For dynamic brake signal	No	No	No	Yes
	CN8: For external alarm signal	Yes	Yes	No	No
	CN4: To connect safety device (for short circuits)	No	No	No	No
	CN4: To connect safety device	Yes	Yes	Yes	Yes
Remarks			For fully-closed control systems		

■ Connecting between servo amplifier units

600 A

Name	Description	Model no.
Copper bar	To connect main power supply between power supply unit and amplifier unit Terminal number: +DC/-DC 2-pc. set (5 mm between units)	AL-00918125-01
Connecting cable between units	To connect between power supply unit (CN9) - Amplifier unit (CN9)	AL-00917284

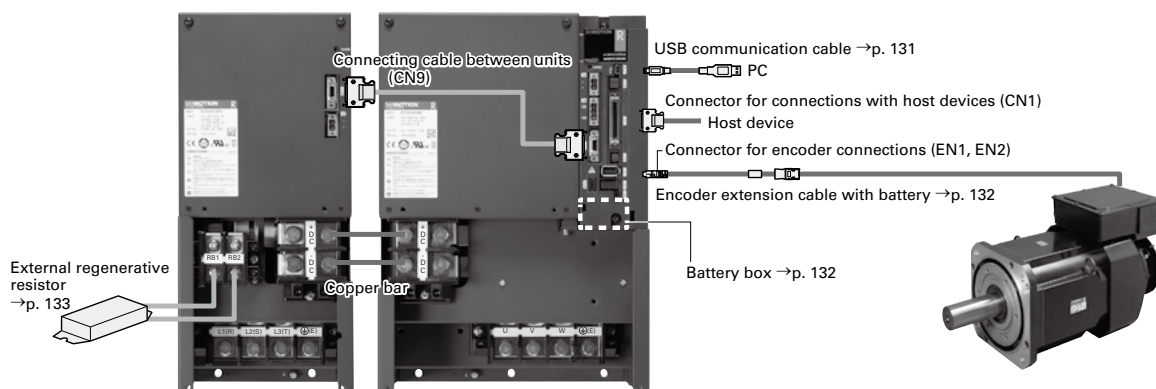

Connector to Connect Servo Amplifier

■ EtherCAT interface type

R ADVANCED

15, 30, 50 A

Individual connectors

Connector no.	Description	Model no.	Manufacturer model no.	Manufacturer
IN, OUT	Ethernet To connect host device	Not available Use a CAT5e standard-compliant shielded type modular plug (RJ-45).		
EN1, EN2	To connect encoder	AL-00632607	A set of 36210-0100PL and 36310-3200-008	3M Japan Limited
CNA*1	For input power supply and regenerative resistor connections	AL-00686902-01	MSTBT2.5/8-STF-5.08LUB	Phoenix Contact.K.K
CNB	To connect to servo motor	AL-Y0004079-01	MSTBT2.5/3-STF-5.08	Phoenix Contact.K.K
CN1	To connect safety device (for wiring)	AL-00718252-01	2013595-3	Tyco Electronics Japan G.K.
CN1*2	To connect safety device (for short circuits)	AL-00849548-02	1971153-2	Tyco Electronics Japan G.K.
CN2	For general I/O	AL-00842383	A set of HDR-E26MSG1+ and HDR-E26LPH	HONDATSUSHIN KOGYO CO., LTD

*1: Amplifiers with built-in regenerative resistor are equipped with a CNA connector.

*2: When CN1 is not wired, be sure to insert a safety device connector (for short circuits) to CN1 on the servo amplifier.

Connector sets

Built-in regenerative resistor		No	Yes	No	Yes
Connector set model no.		AL-00887324	AL-00887322	AL-00887328	AL-00887326
Connectors included in the set	EN1: To connect encoder	Yes	Yes	Yes	Yes
	EN2: To connect encoder	No	No	Yes	Yes
	CNA: To connect input power supply, regenerative resistor	Yes	No	Yes	No
	CNB: For servo motor connection	Yes	Yes	Yes	Yes
	CN1: To connect safety device (for wiring)	Yes	Yes	Yes	Yes
	CN2: General I/O connector	Yes	Yes	Yes	Yes
Remarks				For fully-closed control systems	For fully-closed control systems

100, 150, 300 A

Individual connectors

Connector no.	Description	Model no.	Manufacturer model no.	Manufacturer
IN, OUT	Ethernet To connect host device	Not available Use a CAT5e standard-compliant shielded type modular plug (RJ-45).		
EN1, EN2	To connect encoder	AL-00632607	36210-0100PL and 36310-3200-008	3M Japan Limited
CNA	To input control circuit power supply	AL-Y0005159-01	MSTBT2.5/2-STF-5.08	Phoenix Contact.K.K
CN1	To connect safety device (for wiring)	AL-00718252-01	2013595-3	Tyco Electronics Japan G.K.
CN1	To connect safety device (for short circuits)	AL-00849548-02	1971153-2	Tyco Electronics Japan G.K.
CN2	For general I/O	AL-00842383	A set of HDR-E26MSG1+ and HDR-E26LPH	HONDATSUSHIN KOGYO CO., LTD

Connector sets

Connector set model no.		AL-00887325	AL-00887329
Connectors included in the set	EN1: To connect encoder	Yes	Yes
	EN2: To connect encoder	No	Yes
	CNA: To input control circuit power supply	Yes	Yes
	CN1: To connect safety device	Yes	Yes
	CN2: For general I/O	Yes	Yes
Remarks			For fully-closed control systems

Connector to Connect Servo Amplifier

■ CANopen interface type

R

15, 30, 50 A

Individual connectors Main power supply: 200 VAC, Control circuit power supply: Single-phase 200 VAC

Connector no.	Description	Model no.	Manufacturer model no.	Manufacturer
CN1	To connect host device	AL-00608710	10114-3000PE and 10314-52A0-008	3M Japan Limited
CN2	To connect encoder	AL-00385596	10120-3000PE and 10320-52A0-008	
CNA	To connect input power supply	AL-00329461-01	MSTB2.5/5-STF-5.08	Phoenix Contact.K.K
CNB*1	To connect regenerative resistor and DC reactor	AL-Y0000988-01	IC2.5/6-STF-5.08	
CNC	To connect to servo motor	AL-00329458-01	IC2.5/3-STF-5.08	

*1: Amplifiers with built-in regenerative resistor are equipped with a CNB connector.

Connector sets Main power supply: 200 VAC, Control circuit power supply: Single-phase 200 VAC

Connector set model no.		AL-00661731	AL-00661729
Connectors included in the set	CN1: To connect host device	Yes	Yes
	CN2: To connect encoder	Yes	Yes
	CNA: To connect input power supply	Yes	No
	CNB: To connect regenerative resistor and DC reactor	No	No
	CNC: To connect to servo motor	Yes	No

Individual connectors Main power supply: 200 VAC, Control circuit power supply: 24 VDC

Connector no.	Description	Model no.	Manufacturer model no.	Manufacturer
CN1	To connect host device	AL-00608710	10114-3000PE and 10314-52A0-008	3M Japan Limited
CN2	To connect encoder	AL-00385596	10120-3000PE and 10320-52A0-008	
CNA	To connect input power supply	AL-Y0000988-02	IC2.5/7-STF-5.08	Phoenix Contact.K.K
CNB*1	To connect regenerative resistor and DC reactor	AL-00329460-01	MSTB2.5/2-STF-5.08	
CNC	To connect to servo motor	AL-00329458-01	IC2.5/3-STF-5.08	

*1: Amplifiers with built-in regenerative resistor are equipped with a CNB connector.

Connector sets Main power supply: 200 VAC, Control circuit power supply: 24 VDC

Connector set model no.		AL-00667184	AL-00661729
Connectors included in the set	CN1: To connect host device	Yes	Yes
	CN2: To connect encoder	Yes	Yes
	CNA: To connect input power supply	Yes	No
	CNB: To connect regenerative resistor and DC reactor	Yes	No
	CNC: To connect to servo motor	Yes	No

Connector to Connect Servo Amplifier

■ Built-in positioning function type

R

15 to 300 A

Individual connectors DIO type Main power supply: 200 VAC

Connector no.	Description	Model no.	Manufacturer model no.	Manufacturer
CN1	To connect host device	AL-00385594	10150-3000PE and 10350-52A0-008	3M Japan Limited
CN2	To connect encoder	AL-00385596	10120-3000PE and 10320-52A0-008	
CNA	To connect input power supply	AL-00329461-01	MSTB2.5/5-STF-5.08	Phoenix Contact.K.K
CNB*1	To connect regenerative resistor and DC reactor	AL-Y0000988-01	IC2.5/6-STF-5.08	
CNC	To connect to servo motor	AL-00329458-01	IC2.5/3-STF-5.08	

*1: Amplifiers with built-in regenerative resistor are equipped with a CNB connector.
 · CNA, CNB, and CNC connectors are used for 10 to 50 A.

Connector sets DIO type Main power supply: 200 VAC

Connector set model no.		AL-00393603	AL-00292309
Connectors included in the set	CN1: To connect host device	Yes	Yes
	CN2: To connect encoder	Yes	Yes
	CNA: To connect input power supply	Yes	No
	CNB: To connect regenerative resistor and DC reactor	No	No
	CNC: To connect to servo motor	Yes	No

Individual connectors DIO type Main power supply: 100 VAC

Connector no.	Description	Model no.	Manufacturer model no.	Manufacturer
CN1	To connect host device	AL-00385594	10150-3000PE and 10350-52A0-008	3M Japan Limited
CN2	To connect encoder	AL-00385596	10120-3000PE and 10320-52A0-008	
CNA	To connect input power supply	AL-00329461-02	MSTB2.5/4-STF-5.08	Phoenix Contact.K.K
CNB*1	To connect regenerative resistor and DC reactor	AL-Y0000988-01	IC2.5/6-STF-5.08	
CNC	To connect to servo motor	AL-00329458-01	IC2.5/3-STF-5.08	

*1: Amplifiers with built-in regenerative resistor are equipped with a CNB connector.

Connector sets DIO type Main power supply: 100 VAC

Connector set model no.		AL-00492384	AL-00292309
Connectors included in the set	CN1: To connect host device	Yes	Yes
	CN2: To connect encoder	Yes	Yes
	CNA: To connect input power supply	Yes	No
	CNB: To connect regenerative resistor and DC reactor	No	No
	CNC: To connect to servo motor	Yes	No

Individual connectors RS-485 communication type

Connector no.	Description	Model no.	Manufacturer model no.	Manufacturer
CN1	To connect host device	AL-Y0004290-02	MUF-PK10K-X	J.S.T. Mfg. Co.,Ltd.

CN2, CNA, CNB, and CNC are common to the above DIO type.

Connector to Connect Servo Amplifier

■ Multi-axis pulse input type

R

15, 30 A

Individual connectors for amplifier unit

Connector no.	Description	Model no.	Manufacturer model no.	Manufacturer
CN1	To connect host device	AL-Y0003305-01	55100-0670	Molex
CN2, CN6	To connect encoder	AL-00632607	36310-3200-008 and 36210-0100PL	3M Japan Limited
CNC	To connect to servo motor	AL-00632604	04JFAT-SBXGF-I J-FATOT	J.S.T. Mfg. Co.,Ltd.

Individual connectors for power supply unit

Connector no.	Description	Model no.	Manufacturer model no.	Manufacturer
CNA	To connect input power supply	AL-00632600	05JFAT-SBXGF-I J-FATOT	J.S.T. Mfg. Co.,Ltd.
CNB	To connect regenerative resistor and DC reactor	AL-00632602	06JFAT-SBXGF-I J-FATOT	
CN1A, CN1B	To connect host device	AL-00385594	10150-3000PE and 10350-52A0-008	3M Japan Limited

Connector sets

Connector set model no.		AL-00632611	AL-00632609
Connectors included in the set	CN1: To connect host device	Yes	No
	CN2, CN6: To connect encoder	Yes	No
	CNC: To connect to servo motor	Yes	No
	CNA: To connect input power supply	No	Yes
	CNB: To connect regenerative resistor and DC reactor	No	No
	CN1A, CN1B: To connect host device	No	Yes
Remarks		A set of connectors for amplifier unit	A set of connectors for power supply unit

Connector for Motor Connection

■ Encoder connector Manufacturer: Japan Aviation Electronics Industry Limited

R 3E Model | R ADVANCED | R

R2 Servo Motor

Motor flange size	Combination plug for encoder (with rubber bushing)		Encoder receptacle model number (motor side)	Applicable cable diameter (bushing color phase)	Pin Layout Symbol
	Straight	Angle			
130 mm sq. to 220 mm sq.	JN2DS10SL1-R	JN2FS10SL1-R	JN2AS10ML2-R	φ5.7 to 7.3 mm (Black)	See the encoder wiring diagram for each servo amplifier.
	JN2DS10SL2-R	JN2FS10SL2-R		φ6.5 to 8.0 mm (Gray)	
	JN2DS10SL3-R	JN2FS10SL3-R		φ3.5 to 5.0 mm (Brick)	

Select the correct plug and contacts for the size of cable to be used. The manufacturer's model number and the model number for parts procured from SANYO DENKI are the same number.

Applicable contact for encoder plug*1, 2

Contact size	Category	Applicable contact	
		Socket contact model no.	Applicable wire size
#22	Manual crimp tool type *3, 4	JN1-22-20S-R-PKG100	AWG #20
		JN1-22-22S-PKG100	AWG #21 to #25
		JN1-22-26S-PKG100	AWG #26 to #28
	Solder type	JN1-22-22F-PKG100	AWG #20

*1: Select the correct plug and contacts for the size of cable to be used. The manufacturer's model number and the model number for parts procured from SANYO DENKI are the same number.

*2: When removing a contact that has already been inserted, use a removal tool. Purchase the removal tool from the connector manufacturer (Japan Aviation Electronics Industry Limited).

*3: For the manual crimp tool part number, see the instruction manuals from the connector manufacturer (Japan Aviation Electronics Industry Limited).

*4: Purchase the semi-automatic crimp tool from the manufacturer (Japan Aviation Electronics Industry Limited).

· For the connector and contact instructions, precautions, etc., see the catalogs and instruction manuals from the connector manufacturer (Japan Aviation Electronics Industry Limited).

■ Cooling fan connector Manufacturer: Japan Aviation Electronics Industry Limited

R1, R2 Servo Motor

Motor flange size	Receptacle for cooling fan connection	Standard specification for cooling fan connectors		Waterproof specification for cooling fans		Pin Layout Symbol		
		(1) Plug (manufacturer model number) (2) Cable clamp (manufacturer model number) (3) Plug + cable clamp (SANYO DENKI part numbers)		Plug (cable clamp)				
		Straight	Angle	Straight	Angle			
180 mm sq. to 220 mm sq. single-phase fan	N/MS3102A10SL-4P	(1) N/MS3106B10SL-4S (2) N/MS3057-4A (3) MS06B10SL-4S-4	(1) N/MS3108B10SL-4S (2) N/MS3057-4A (3) MS08B10SL-4S-4	JA06A-10SL-4S-J1-R (Conduit)	—	A	B	—

R2 Servo Motor

Motor flange size	Receptacle for cooling fan connection	Standard specification for cooling fan connectors		Pin Layout Symbol				
		(1) Plug (manufacturer model number) (2) Cable clamp (manufacturer model number) (3) Plug + cable clamp (SANYO DENKI part numbers)		U	V	W	Ground	Thermos
		Straight	Angle					
220 mm sq. 3-phase fan	JL04V-2E18-12PE-B-R	(1) JL04V-6A18-12SE-EB-R (2) JL04-18CK(13)-R (3) 332706X3	(1) JL04V-8A18-12SE-EBH-R (2) JL04-18CK(13)-R (3) 332707X3	A	B	C	—	E, F

· See the catalogs and instruction manuals issued by the connector manufacturer (Japan Aviation Electronics Industry Limited) for how to handle the items and precautions.
· Conduit is not provided..

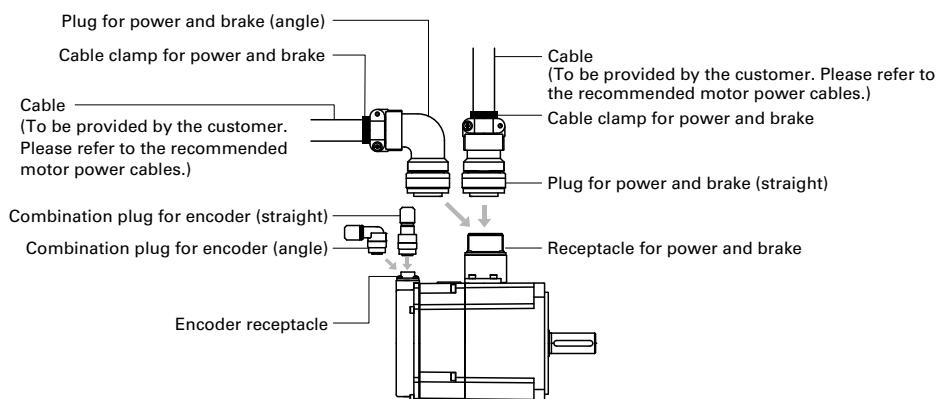

Power Connector to Connect Motor, Electric Wire Size

Manufacturer: Japan Aviation Electronics Industry Limited

R 3E Model

RADVANCED

R

Flange size (mm)	Motor model no.	For power standard specification (1) Plug (manufacturer model no.) (2) Cable clamp (manufacturer model no.) (3) Plug + cable clamp (SANYO DENKI part numbers)		For power waterproofing specification TÜV standard plug (1) Plug (manufacturer model no.) (2) Cable clamp (manufacturer model no.) (3) Plug + cable clamp (SANYO DENKI part numbers)		For brake standard specification waterproof specification TÜV standard plug (1) Plug (manufacturer model no.) (2) Cable clamp (manufacturer model no.) (3) Plug + cable clamp (SANYO DENKI part numbers)		
		Straight	Angle	Straight	Angle	Straight	Angle	
130 sq.	R2AA13050					Same part number as for power		
	R2AA13120	(1) N/MS3106B24-11S	(1) N/MS3108B24-11S	(1) JL04V-6A24-11SE-EB-R	(1) JL04V-8A24-11SE-EB-R			
	R2AA13180	(2) N/MS3057-16A	(2) N/MS3057-16A	(2) JL04-2428CK-R	(2) JL04-2428CK-R			
	R2AA13200	(3) MS06B24-11S-16	(3) MS08B24-11S-16	(3) 332706X10	(3) 332707X10			
180 sq.	R2AA18350L	(1) N/MS3106B24-11S	(1) N/MS3108B24-11S	(1) JL04V-6A24-11SE-EB-R	(1) JL04V-8A24-11SE-EB-R	Same part number as for power		
	R2AA18350D	(2) N/MS3057-16A	(2) N/MS3057-16A	(2) JL04-2428CK-R	(2) JL04-2428CK-R			
	R2AA18450H	(3) MS06B24-11S-16	(3) MS08B24-11S-16	(3) 332706X10	(3) 332707X10			
	R2AA18550R					(1) JL04V-6A10SL-3SE-EB-R	(1) JL04V-8A10SL-3SE-EB-R	
	R2AA18550H	(1) N/MS3106B32-17S	(1) N/MS3108B32-17S	(1) JL04V-6A32-17SE-R (Conduit)	—	(2) JL04-1012CK-R	(2) JL04-1012CK-R	
	R2AA18750H	(2) N/MS3057-20A	(2) N/MS3057-20A	(3) 332706X1		(3) 332706X1	(3) 332707X1	
	R2AA1811KR	(3) MS06B32-17S-20	(3) MS08B32-17S-20	(3) JL04V-6A32-17SE				
220 sq.	R2AA22500L	(1) N/MS3106B24-11S	(1) N/MS3108B24-11S	(1) JL04V-6A24-11SE-EB-R	(1) JL04V-8A24-11SE-EB-R	Same part number as for power		
	R2AA22700S	(2) N/MS3057-16A	(2) N/MS3057-16A	(2) JL04-2428CK-R	(2) JL04-2428CK-R			
	R2AA2211KB	(3) MS06B24-11S-16	(3) MS08B24-11S-16	(3) 332706X10		(1) JL04V-6A10SL-3SE-EB-R	(1) JL04V-8A10SL-3SE-EB-R	
	R2AA2215KB	(1) N/MS3106B32-17S	(1) N/MS3108B32-17S	(1) JL04V-6A32-17SE-R (Conduit)	—	(2) JL04-1012CK-R	(2) JL04-1012CK-R	
275 sq.	R2AA2830KV	Terminal block; therefore, plug is not necessary						
	R1AA18550H							
	R1AA18750L	(1) N/MS3106B32-17S	(1) N/MS3108B32-17S	(1) JL04V-6A32-17SE-R (Conduit)	—	(1) JL04V-6A10SL-3SE-EB-R	(1) JL04V-8A10SL-3SE-EB-R	
	R1AA1811KR	(2) N/MS3057-20A	(2) N/MS3057-20A	(3) JL04V-6A32-17SE		(2) JL04-1012CK-R	(2) JL04-1012CK-R	
180 sq.	R1AA1815KB	(3) MS06B32-17S-20	(3) MS08B32-17S-20			(3) 332706X1	(3) 332707X1	

Flange size (mm)	Motor model no.	Receptacle for power (motor side)	Receptacle for brake (motor side)	Pin layout symbol					Applicable amplifier capacity	Recommended motor power wire size (U, V, W, GND)		Wire size of main power supply (R, S, T, GND)	
				U phase	V phase	W phase	Ground	Brake		mm ²	AWG No.	mm ²	AWG No.
130 sq.	R2AA13050H	JL04V-2E24-11PE-B-R	Same part number as for power	D	E	F	G, H	A, B	30 A	0.75	#19	2	#14
	R2AA13050D			D	E	F	G, H	A, B	50 A	2	#14	2	#14
	R2AA13120B			D	E	F	G, H	A, B	100 A	5.5	#10	5.5	#10
	R2AA13120L			D	E	F	G, H	A, B	50 A	2	#14	2	#14
	R2AA13120D			D	E	F	G, H	A, B	100 A	5.5	#10	5.5	#10
	R2AA13180H			D	E	F	G, H	A, B	150 A	8	#8	8	#8
	R2AA13180D			D	E	F	G, H	A, B	300 A	14	#6	14	#6
	R2AA13200L			D	E	F	G, H	A, B	300 A	14	#6	14	#6
180 sq.	R2AA18350L	JL04V-2E24-11PE-B-R	Same part number as for power	D	E	F	G, H	A, B	150 A	5.5	#10	8	#8
	R2AA18350D			D	E	F	G, H	A, B	150 A	5.5	#10	8	#8
	R2AA18450H			D	E	F	G, H	A, B	150 A	5.5	#10	8	#8
	R2AA18550R	JL04V-2E32-17PE-B-R	JL04V-2E10SL-3PE-B-R	A	B	C	D	A, B	300 A	14	#6	14	#6
	R2AA18550H			A	B	C	D	A, B	300 A	14	#6	14	#6
	R2AA18750H			A	B	C	D	A, B	300 A	14	#6	14	#6
R2AA1811KR	A	B	C	D	A, B	300 A	14	#6	14	#6			
220 sq.	R2AA22500L	JL04V-2E24-11PE-B-R	Same part number as for power	D	E	F	G, H	A, B	150 A	5.5	#10	8	#8
	R2AA22700S			D	E	F	G, H	A, B	150 A	5.5	#10	8	#8
	R2AA2211KB	JL04V-2E32-17PE-B-R	JL04V-2E10SL-3PE-B-R	A	B	C	D	A, B	300 A	14	#6	14	#6
	R2AA2215KB			A	B	C	D	A, B	300 A	14	#6	14	#6
275 sq.	R2AA2830KV	Terminal block: UF1005-150A-3P (M8, Hexagon bolt)	Terminal block: F1005-20S-5P (M4, Screws)	—	—	—	—	—	600 A	38	#2	38	#2
180 sq.	R1AA18550H	JL04V-2E32-17PE-B-R	JL04V-2E10SL-3PE-B-R	A	B	C	D	A, B	300 A	14	#6	14	#6
	R1AA18750L			A	B	C	D	A, B	300 A	14	#6	14	#6
	R1AA1811KR			A	B	C	D	A, B	300 A	14	#6	14	#6
	R1AA1815KB			A	B	C	D	A, B	300 A	14	#6	14	#6

• See the catalogs and instruction manuals of the connector manufacturer (Japan Aviation Electronics Industry Limited) for how to handle the items and precautions.
• Conduit is not provided.

Cable

■USB communication cable for setup software

R 3E Model

PC communication cable for setup software

Cable length: L (m)	Model no.
1.0	AL-00896515-01
2.0	AL-00896515-02

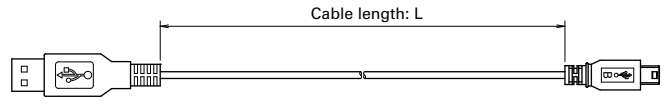

PC side (Series A) Servo amplifier side (Series mini B)
Specifications and external drawings may be changed without prior notice.

■Communication cable between amplifiers for tandem operation

R 3E Model

Connects between amplifiers for tandem operation. (CN5⇔CN5)

Cable length: L (m)	Model no.
0.2	AL-00911582-01
3.0	AL-00911582-02

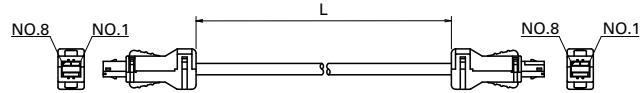

Note that the wiring differs from the communication cable between amplifiers for R ADVANCED MODEL (Model number: AL-00695974-□□).

■PC communication cable for setup software

R ADVANCED

PC communication cable for setup software

Cable length: L (m)	Model no.
2.85	AL-00689703-01

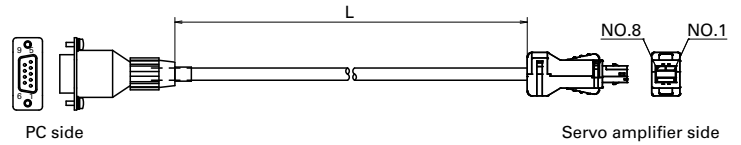

PC side

Servo amplifier side

■PC communication cable for setup software

R

PC communication cable for setup software

Cable length: L (m)	Model no.
2.85	AL-00490833-01

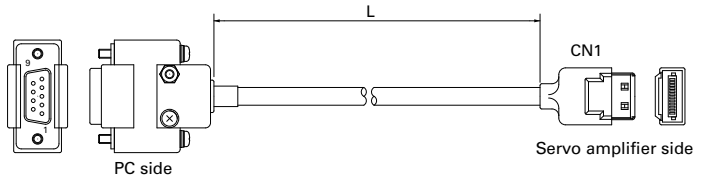

PC side

Servo amplifier side

Battery for Battery-backup Method Absolute Encoder and Related Parts

Battery box

R 3E Model

Name	Description	Model no.
1) Battery box *With 10 to 50 A amplifiers, the front mounting brackets cannot be used.	A set of lithium battery ER3VLY and battery box	AL-00880402-01
2) Battery for battery box (Lithium battery)	Lithium battery: ER3VLY from Toshiba Lifestyle Products & Services Corporation	AL-00879511-01

1) Battery box (Model no.: AL-00880402-01)

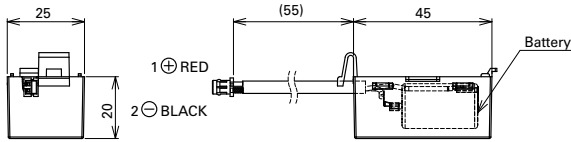

2) Replacement battery for use with battery box (Model no.: AL-00879511-01)

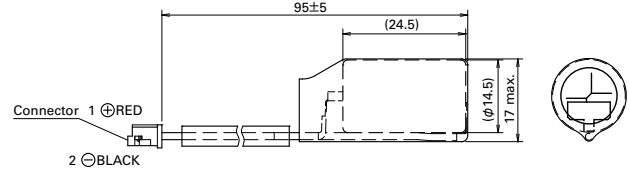

Encoder extension cable with battery

R 3E Model R ADVANCED

Name	Description	Model no.
3) Encoder extension cable with battery and connectors on both ends	No	AL-00731792-01
4) Encoder extension cable with battery and connectors on one end	No	AL-00697960-□□
5) Replacement battery for encoder cable (Lithium battery)	Lithium battery: ER3VLY from Toshiba Lifestyle Products & Services Corporation	AL-00697958-01

3) Encoder cable attached to battery, with connectors on both ends (Model no.: AL-00731792-01)

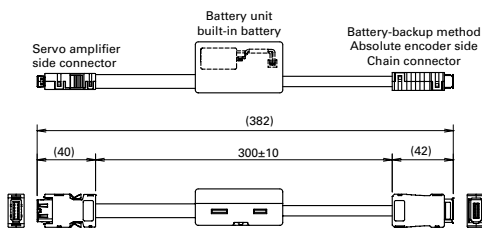

4) Encoder cable attached to battery, with connector on one end (Model no.: AL-00697960-□□)

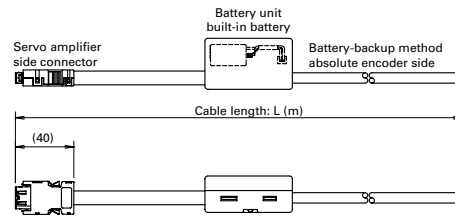

5) Replacement battery for encoder cable with battery (Model no.: AL-00697958-01)

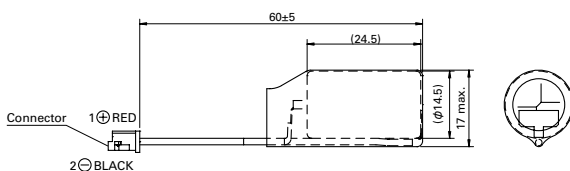

	Model no.	L [m]
1	AL-00697960-01	3
2	AL-00697960-02	5
3	AL-00697960-03	10
4	AL-00697960-04	15
5	AL-00697960-05	20
6	AL-00697960-06	25

Battery

R

Name	Model no.
Lithium battery	AL-00494635-01

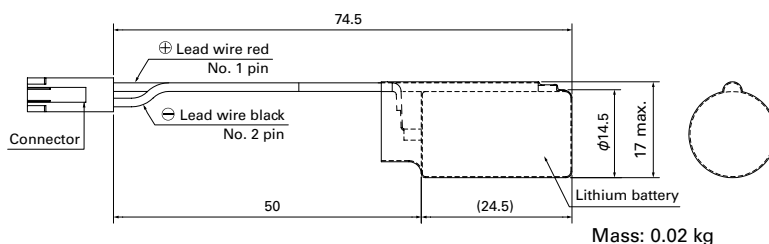

Analog Monitor

R 3E Model R ADVANCED

This is an analog monitor which can display the velocity waveform with an oscilloscope for system maintenance or when tuning.

Name	Description	Model no.
1) Monitor box	Monitor box body 2 dedicated cables	Q-MON-3
2) Dedicated cable	1 dedicated cables	AL-00690525-01

1) Monitor box (Model no.: Q-MON-3)

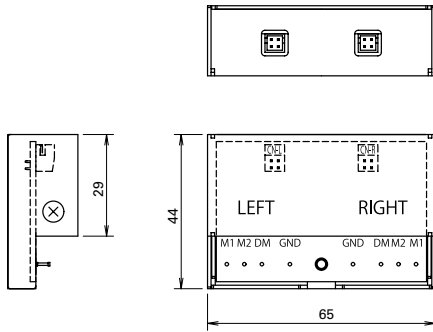

2) Dedicated cable (Model no.: AL-00690525-01)

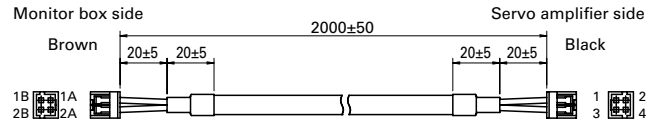

*1 2 units of the dedicated cables per above 2) (PN# AL-00690525-01) are attached to monitor box (PN#Q-MON-3).

*2 Power is supplied from the servo amplifier.

External Regenerative Resistor

R 3E Model R ADVANCED R

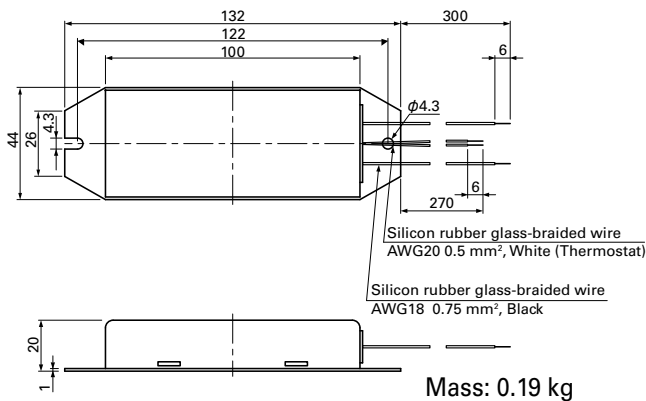

	Model no.	Thermostat
1	REGIST-080W50B	Normally closed
2	REGIST-080W100B	Normally closed

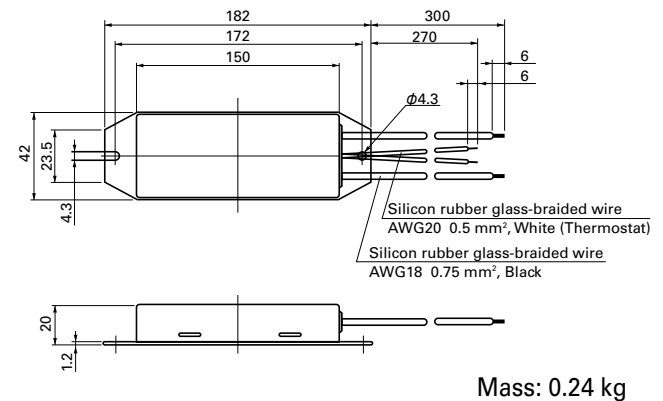

	Model no.	Thermostat
1	REGIST-120W50B	Normally closed
2	REGIST-120W100B	Normally closed

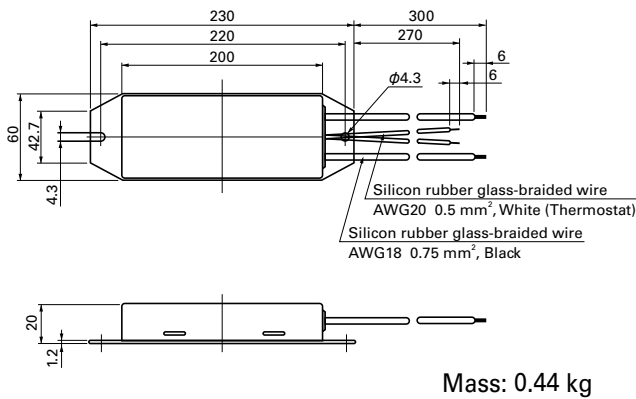

	Model no.	Thermostat
1	REGIST-220W20B	Normally closed
2	REGIST-220W50B	Normally closed
3	REGIST-220W100B	Normally closed

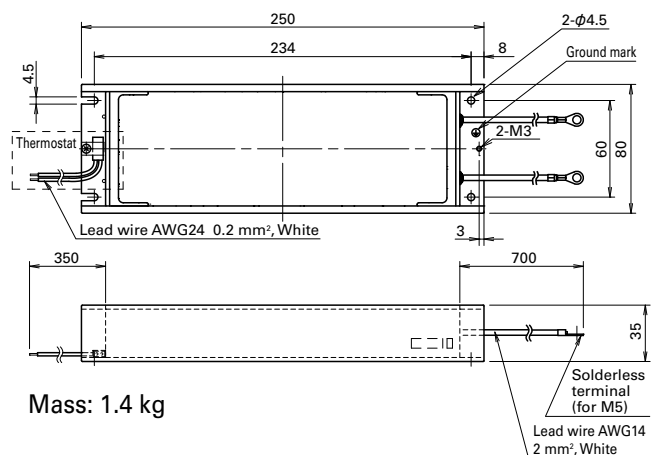

	Model no.	Thermostat
1	REGIST-500CW7B	Normally closed
2	REGIST-500CW10B	Normally closed
3	REGIST-500CW14B	Normally closed
4	REGIST-500CW20B	Normally closed

Front Mounting Brackets

■ For Analog/Pulse input type

R 3E Model

Brackets for mounting the servo amplifier on the front (connector side).

Applicable servo amplifiers	Model no.	Set contents
10, 20, 30 A (RS3□01, 02, 03)	AL-00880390-01	Top/bottom mounting brackets: 1 each Clamping screws: 4
50 A (RS3□05)	AL-00880391-01	Top/bottom mounting brackets: 1 each Clamping screws: 4
100, 150 A (RS3□10, 15)	AL-00907039-01	Top/bottom mounting brackets: 1 each Clamping screws: 6
300 A (RS3□30)	AL-00907040-01	Top/bottom mounting brackets: 1 each Clamping screws: 8

- Trivalent chrome plating is used. (Surface color is silver-blue, and different from body color.)
- Cannot be used with battery box. (10 to 50 A)

10, 20, 30 A
AL-00880390-01
Upper side

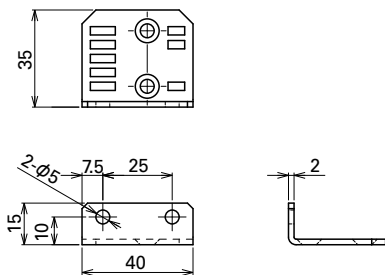

Lower side

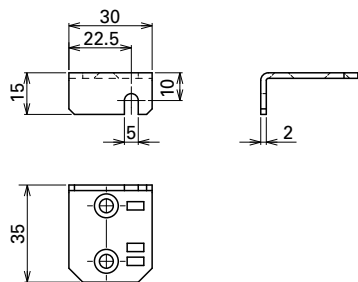

100, 150 A
AL-00907039-01
Common to upper side/lower side

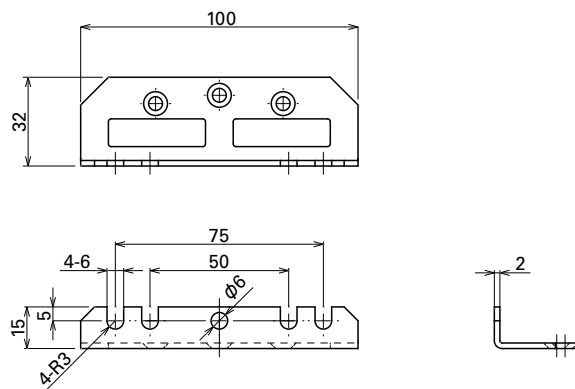

300 A
AL-00907040-01
Upper side

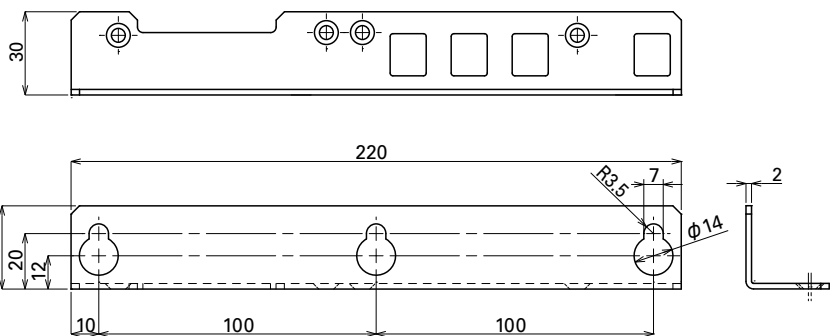

Lower side

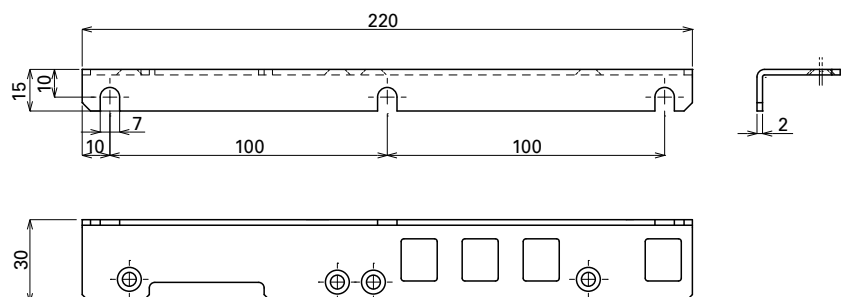

50 A
AL-00880391-01
Upper side

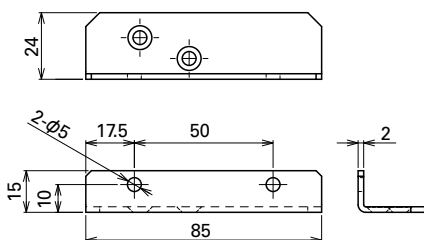

Lower side

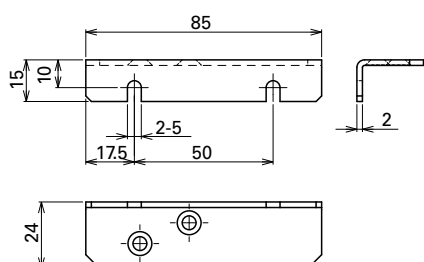

Mounting example

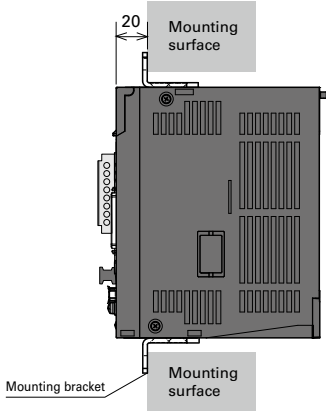

Mounting board dimension examples for reference

10, 20 A

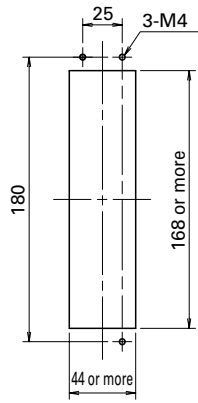

30 A

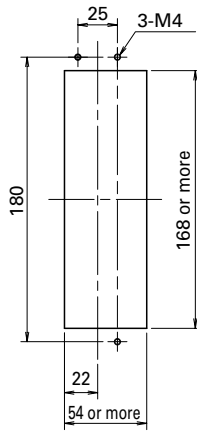

50 A

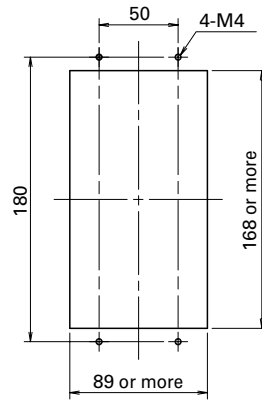

100 A

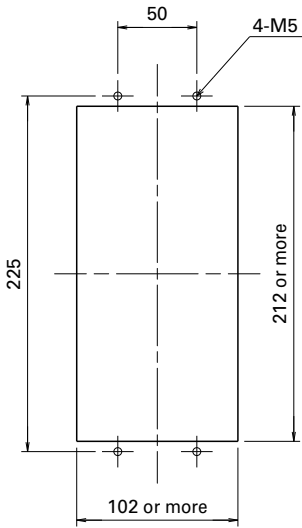

150 A

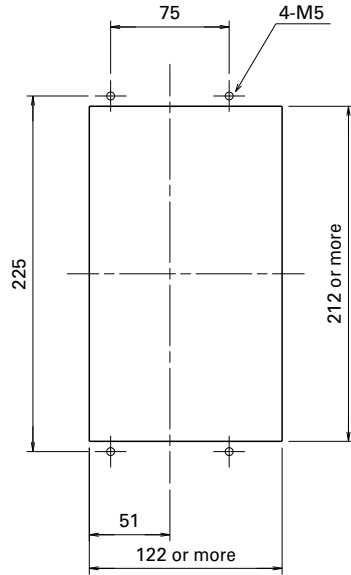

300 A

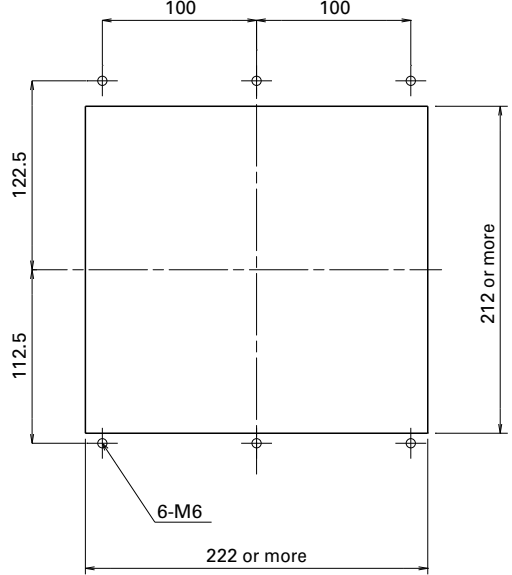

Front Mounting Brackets

■ EtherCAT interface type

R ADVANCED

Brackets for mounting the servo amplifier on the front (connector side).

Applicable servo amplifiers	Model no.	Set contents
15, 30 A (RS2□01, 03)	AL-00736863-01	Top/bottom mounting brackets: 1 each Clamping screws: 4
50 A (RS2□05)	AL-00736864-01	Top/bottom mounting brackets: 1 each Clamping screws: 4
300 A (RS2□30)	AL-00828413-01	Top/bottom mounting brackets: 1 each Clamping screws: 8

- Trivalent chrome plating is used. (Surface color is silver-blue, and different from body color.)
- For 100 A and 150 A (RS2□10/15), the rear mounting brackets can be removed and attached onto the front of the servo amplifier.

15, 30 A
AL-00736863-01
Upper side

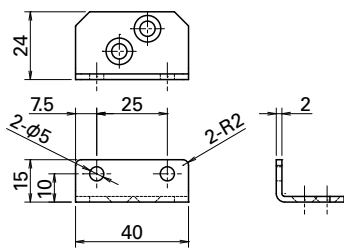

Lower side

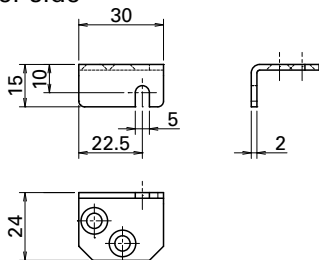

50 A
AL-00736864-01
Upper side

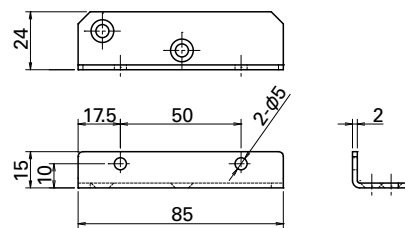

Lower side

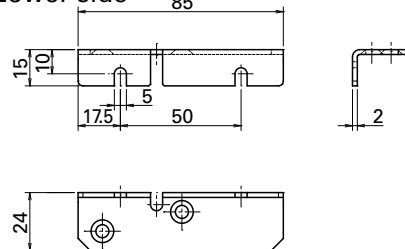

300 A
AL-00828413-01
Upper side

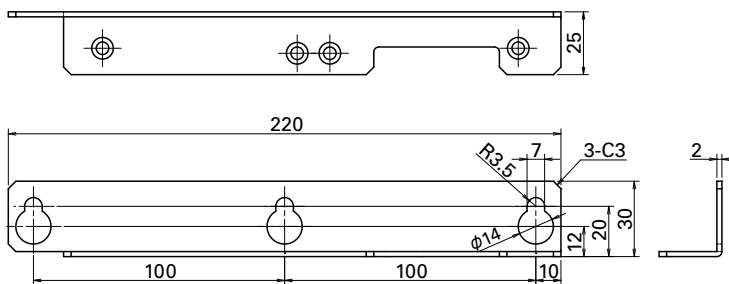

Lower side

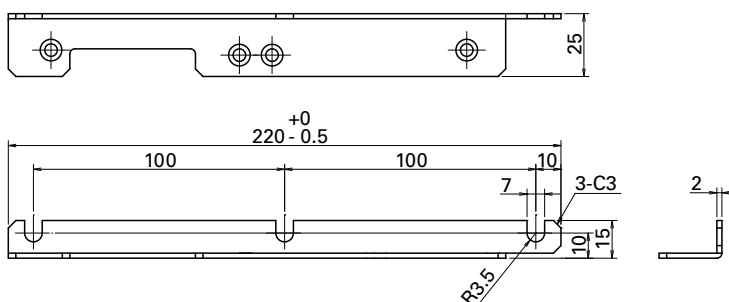

Mounting Brackets

■ Built-in positioning function type

R

Note that CANopen interface type servo amplifiers and multi-axis pulse input type servo amplifiers are not supported.

Applicable servo amplifiers	Model no.	Description	Set contents
15, 30 A (RS1□01, 03)	AL-00582791-01	For mounting on the servo amplifier rear surface	Mounting brackets: 1 Clamping screws: 2
50 A (RS1□05)	AL-00582792-01	For mounting on the servo amplifier rear surface	Mounting brackets: 1 Clamping screws: 2
15 A (RS1□01)	AL-00582788-01	For mounting on the servo amplifier front surface	Mounting brackets: 1 Clamping screws: 6
30 A (RS1□03)	AL-00582789-01	For mounting on the servo amplifier front surface	Mounting brackets: 1 Clamping screws: 6
50 A (RS1□05)	AL-00582790-01	For mounting on the servo amplifier front surface	Mounting brackets: 1 Clamping screws: 6

15, 30 A (rear)
AL-00582791-01

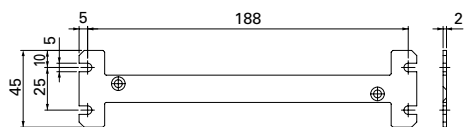

50 A (rear)
AL-00582792-01

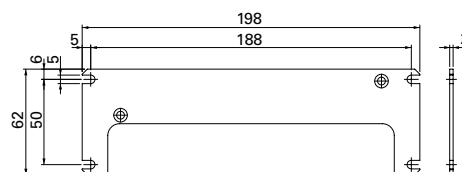

15 A (front)
AL-00582788-01

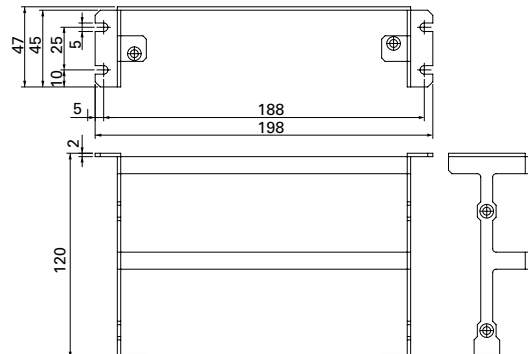

30 A (front)
AL-00582789-01

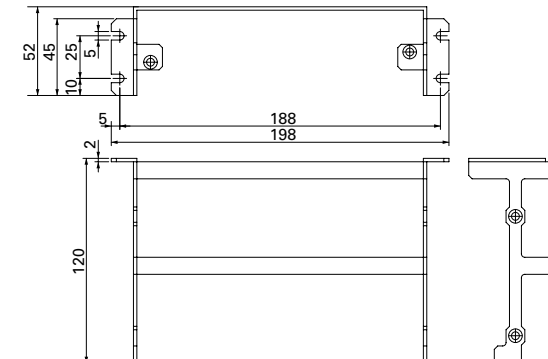

50 A (front)
AL-00582790-01

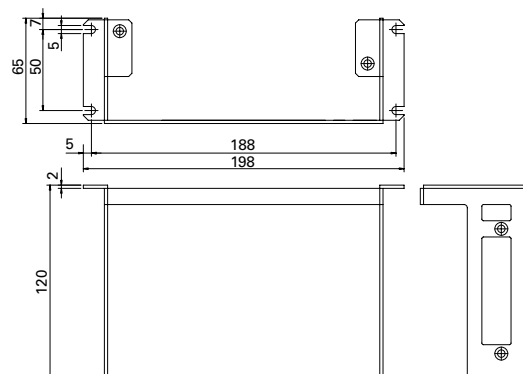

Servo Motor with Servo Motor Extension Cable and Connectors

Extension cable for servo motor dimensions

Power cable

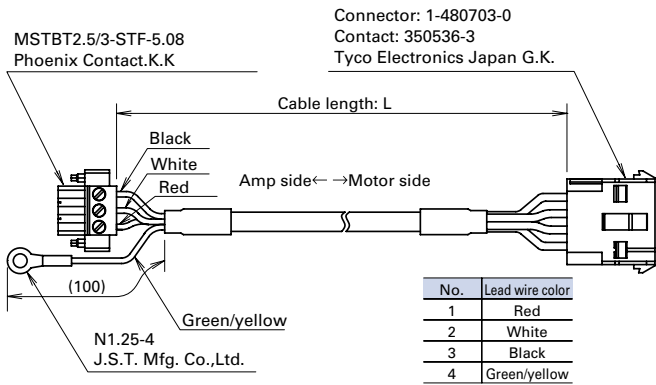

Encoder cable

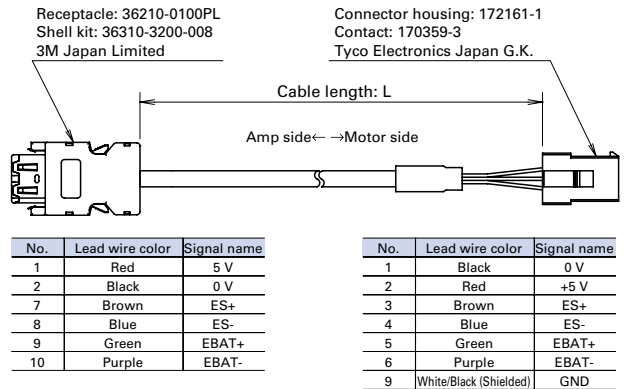

Brake cable

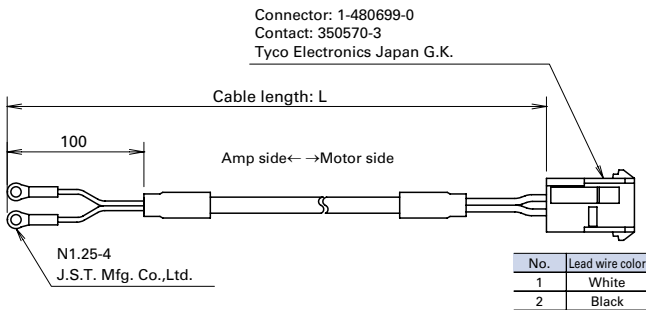

Model no.			Cable length: L (m)
Power cable	Brake cable	Encoder cable	
RS-CM4-01-R	RS-CB3-01-R	RS-CA4-01-R	1
RS-CM4-02-R	RS-CB3-02-R	RS-CA4-02-R	2
RS-CM4-03-R	RS-CB3-03-R	RS-CA4-03-R	3
RS-CM4-05-R	RS-CB3-05-R	RS-CA4-05-R	5
RS-CM4-10-R	RS-CB3-10-R	RS-CA4-10-R	10

Servo motors with connectors for extension cables

200 V system

Rated output	Motor flange size	Holding brake	Model no.
30 W	40 mm sq.	—	R2AA04003FXPA0
30 W	40 mm sq.	Yes (24 VDC)	R2AA04003FCPA0
50 W	40 mm sq.	—	R2AA04005FXPA0
50 W	40 mm sq.	Yes (24 VDC)	R2AA04005FCPA0
90 W	40 mm sq.	Yes (24 VDC)	R2AA04010FCPA0
100 W	40 mm sq.	—	R2AA04010FXPA0
100 W	60 mm sq.	—	R2AA06010FXPA0
100 W	60 mm sq.	Yes (24 VDC)	R2AA06010FCPA0
200 W	60 mm sq.	—	R2AA06020FXPA0
200 W	60 mm sq.	Yes (24 VDC)	R2AA06020FCPA0
360 W	60 mm sq.	Yes (24 VDC)	R2AA06040FCPA0
400 W	60 mm sq.	—	R2AA06040FXPA0
750 W	60 mm sq.	—	R2AA08075FXPA0
750 W	80 mm sq.	Yes (24 VDC)	R2AA08075FCPA0

Protection code: IP67. CE/UL approval: no.
Encoder classification: battery-backup method absolute encoder (PA035C).
Output shaft: straight. Oil seal: no.

Connectors are connected as shown in the figure. The cable length is 200 ±30 mm.

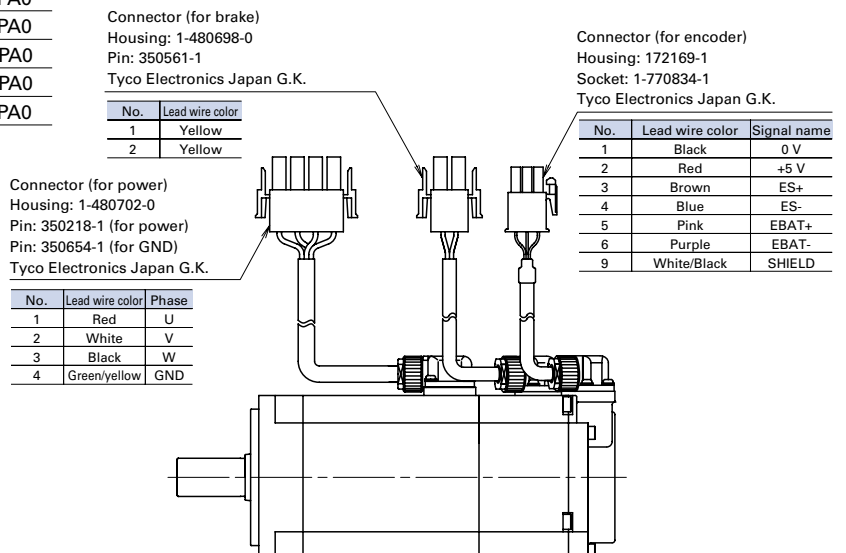

Linear Servo Motors

Flat type with core

Dual magnet type with core

Linear servo motors featuring large thrust force.
Compatible with R 3E Model servo amplifiers.
Contact us for the model numbers of the compatible amplifiers.

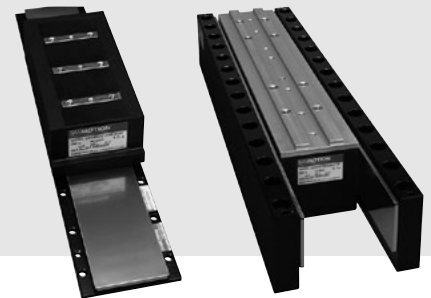

How to read model numbers

Note that not all the possible combinations of the numbers and characters below are valid. Also, some of the numbers/characters listed below are for optional models.

Coil

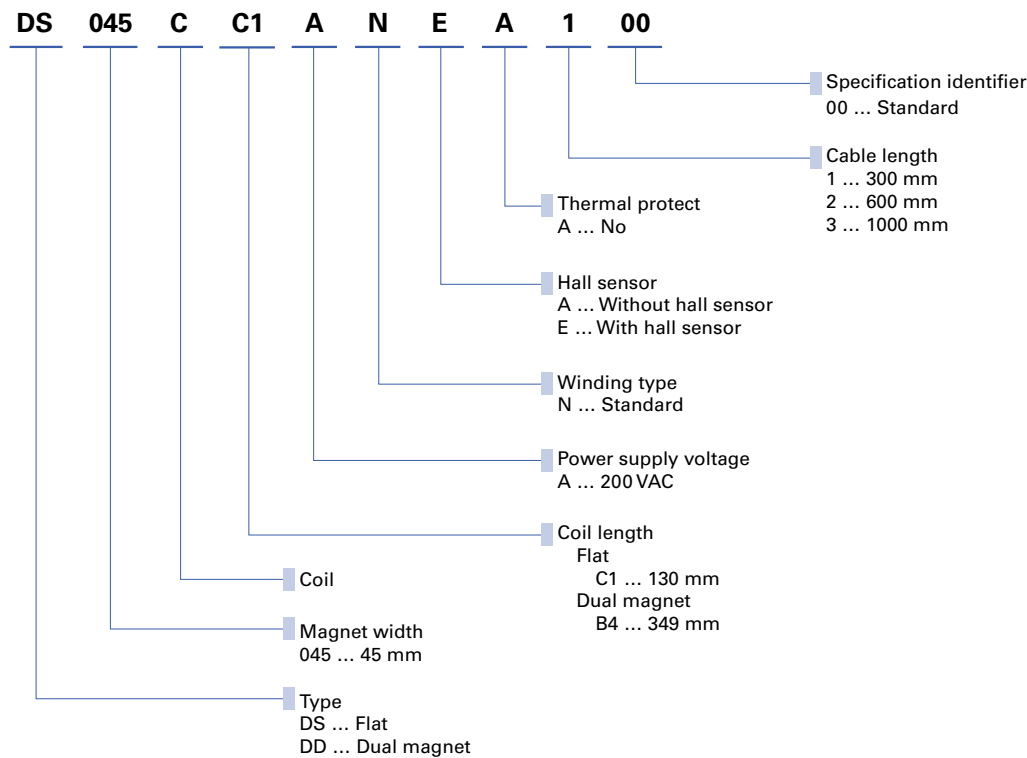

Magnet rail

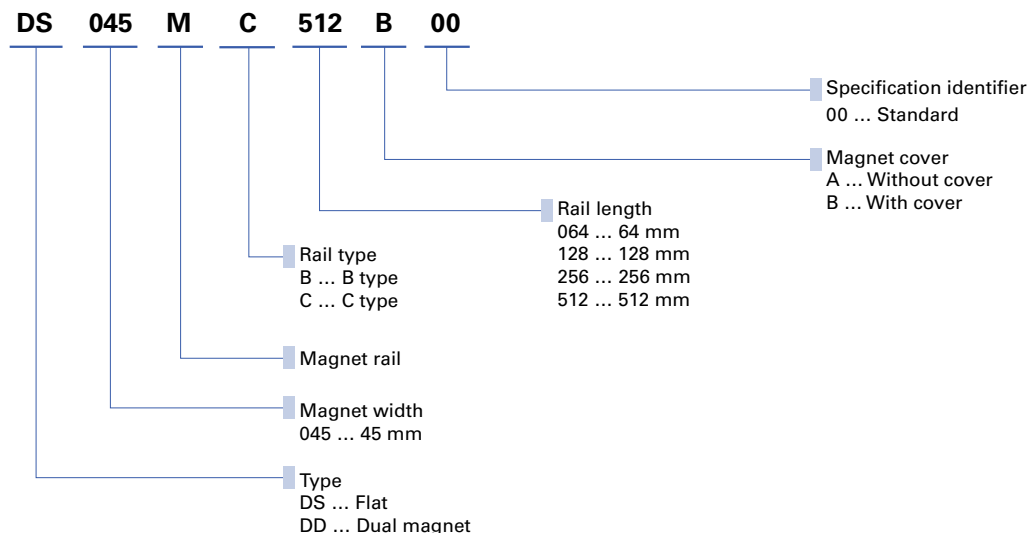

System Configuration

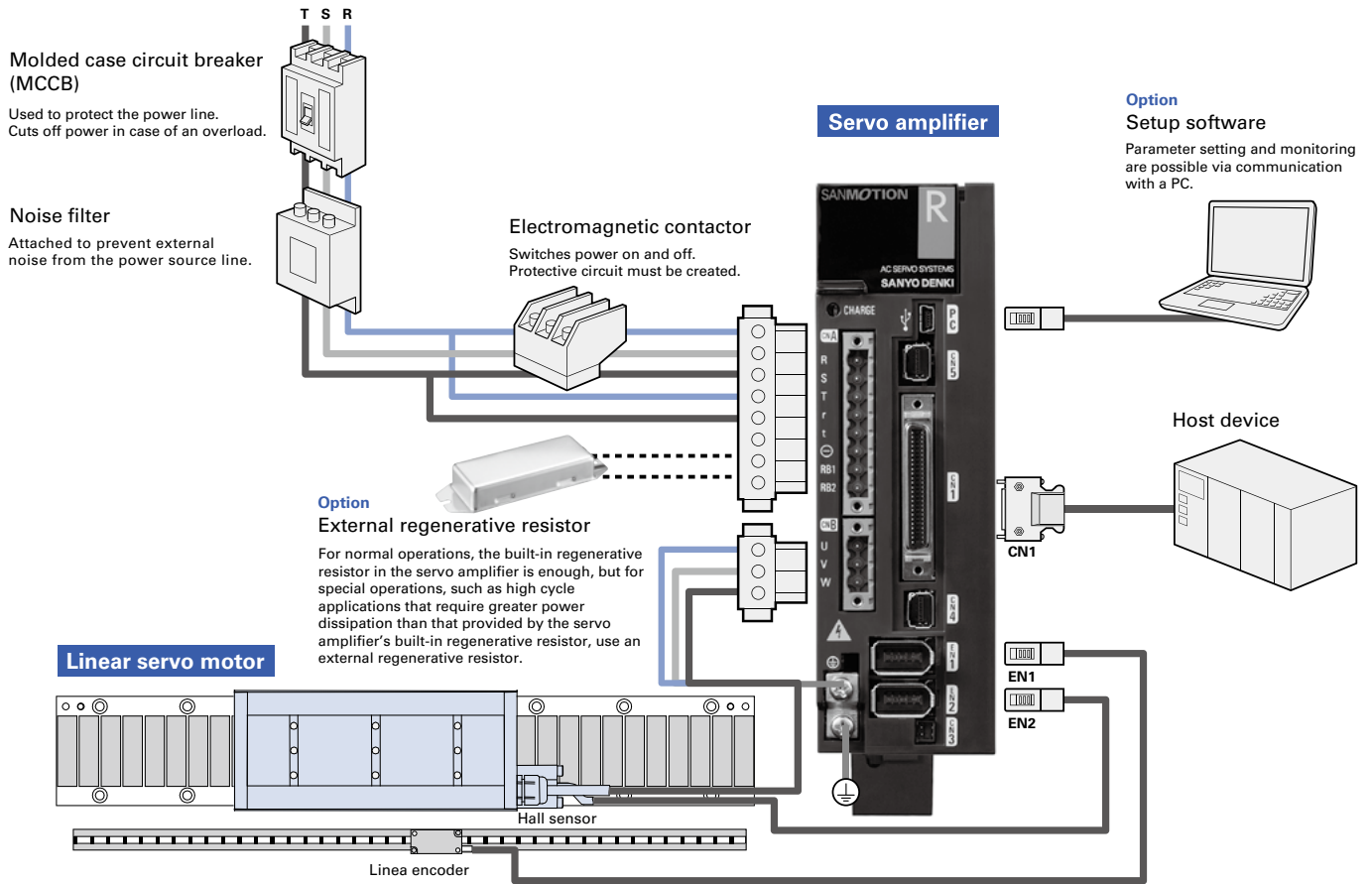

Options

■ Connector to connect servo amplifier

R 3E Model

10 to 50 A

Individual connectors

Connector no.	Item	Model no.	Manufacturer model no.	Manufacturer
CN1	To connect host device	AL-00385594	10150-3000PE and 10350-52A0-008	3M Japan Limited
EN1, EN2	For linear encoder and hall sensor connections	AL-00632607	36210-0100PL and 36310-3200-008	
CNA*1	For input power supply and regenerative resistor connections	AL-00686902-01	MSTBT2.5/8-STF-5.08LUB	Phoenix Contact.K.K
CNB	For linear motor connection	AL-Y0004079-01	MSTBT2.5/3-STF-5.08	
CN4*2	To connect safety device (for short circuits)	AL-00718251-01	2040978-1	Tyco Electronics Japan G.K.
CN4	To connect safety device	AL-00718252-01	2013595-3	

*1: Amplifiers with built-in regenerative resistor are equipped with a CNA connector.

*2: When CN4 is not wired, be sure to insert a safety device connector (for short circuits) to CN4 on the servo amplifier.

Connector sets (no Safe Torque Off function)

Connector no.	Item	Model no.	Compatible servo amplifier model no.	Remarks
CN1, EN1, CNA, CNB	Standard set without hall sensor	AL-00723282	RS3□□□L0□L0/ RS3□□□L8□L0	Without regenerative resistor
CN1, EN1, CNB		AL-00723284	RS3□□□L0□A0/ RS3□□□L8□A0	With regenerative resistor
CN1, EN1, EN2, CNA, CNB	Standard set with hall sensor	AL-00723286	RS3□□□LA□L0/ RS3□□□LB□L0	Without regenerative resistor
CN1, EN1, EN2, CNB		AL-00723288	RS3□□□LA□A0/ RS3□□□LB□L0	With regenerative resistor
CN1, EN1	Low-voltage set without hall sensor	AL-00723290	RS3□□□L0□□0/ RS3□□□L8□□0	—
CN1, EN1, EN2	Low-voltage set with hall sensor	AL-00781940	RS3□□□LA□□0/ RS3□□□LB□□0	—
CNA, CNB	High-voltage set	AL-00696037	RS3□□□L□□L0	Without regenerative resistor

Connector sets (with Safe Torque Off function)

Connector no.	Item	Model no.	Compatible servo amplifier model no.	Remarks
CN1, EN1, CNA, CNB, CN4	Standard set without hall sensor	AL-00723155	RS3□□□L0□L2(4)/ RS3□□□L8□L2(4)	Without regenerative resistor
CN1, EN1, CNB, CN4		AL-00723156	RS3□□□L0□A2(4)/ RS3□□□L8□A2(4)	With regenerative resistor
CN1, EN1, EN2, CNA, CNB, CN4	Standard set with hall sensor	AL-00723157	RS3□□□LA□L2(4)/ RS3□□□LB□L2(4)	Without regenerative resistor
CN1, EN1, EN2, CNB, CN4		AL-00723158	RS3□□□LA□A2(4)/ RS3□□□LB□A2(4)	With regenerative resistor
CN1, EN1, CN4	Low-voltage set without hall sensor	AL-00723159	RS3□□□L0□□2(4)/ RS3□□□L8□□2(4)	—
CN1, EN1, EN2, CN4	Low-voltage set with hall sensor	AL-00781942	RS3□□□LA□□2(4)/ RS3□□□LB□□2(4)	—

* Connector CN4 included in a set is for safety device connection. Model no.: AL-00718252-01

Flat Type with Core

Specifications

Coil model no.	Rated thrust [N]	Max. thrust [N]	Rated speed [m/s]	Max. speed [m/s]	Magnetic attraction force [N]	Mass of movable element [kg]	Compatible magnet rail model no.	Compatible servo amplifier model no.
DS045CC1AN	260	500	1.8	3.0	1700	1.8	DS045MC□□□□	RS□A03L

Magnet rail model no.	Magnet rail mass [kg]	Dimensions			
		L1	L2	N1	N2
DS045MC064	0.2	64	32	1	4
DS045MC128	0.4	128	96	3	8
DS045MC256	0.8	256	224	7	16
DS045MC512	1.5	512	480	15	32

Thrust-Speed Characteristics

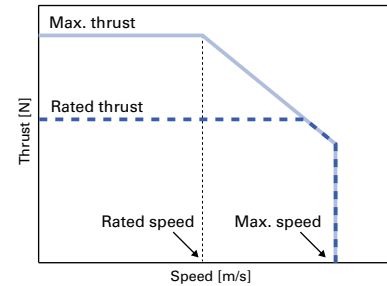

Coil dimensions

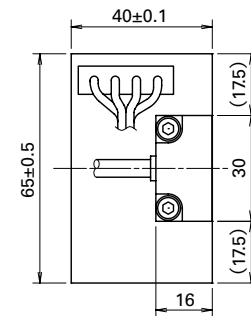
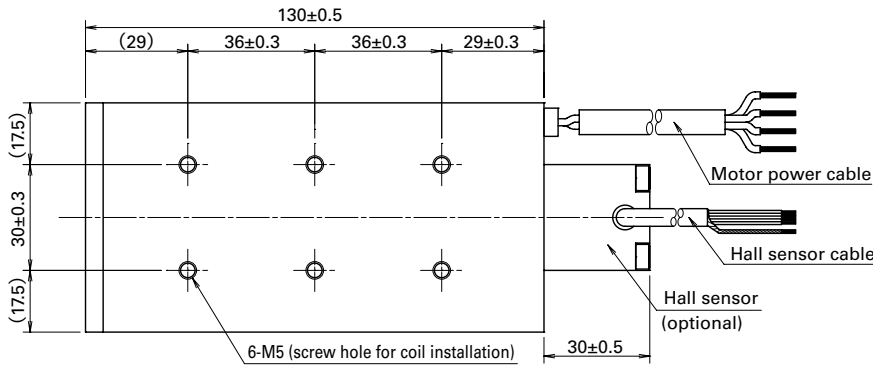

Magnet rail dimensions

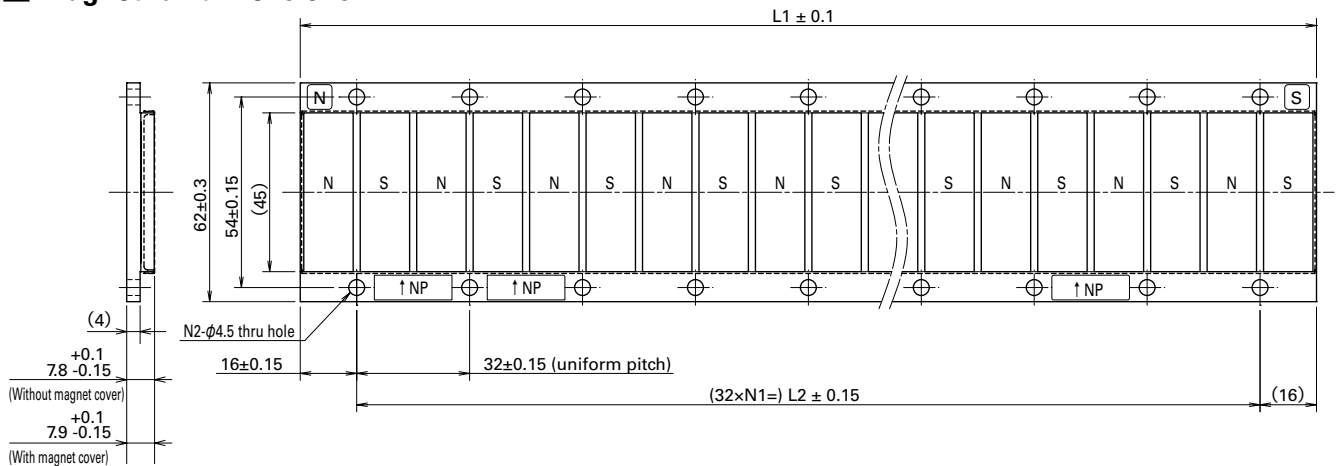
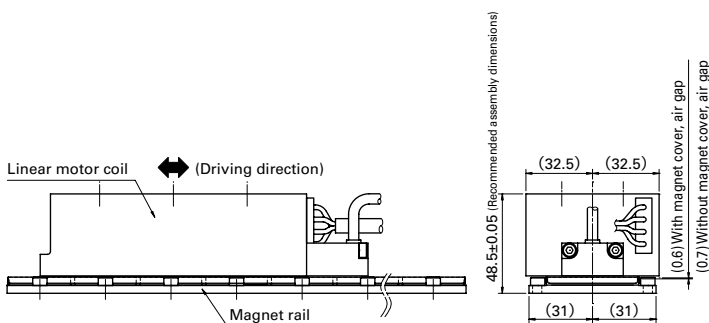
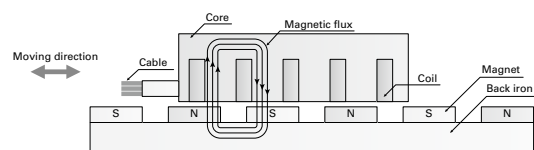

Diagram of recommended assembly example



Motor cross section (side view)



Dual Magnet Type with Core

Specifications

Coil model no.	Rated thrust [N]	Max. thrust [N]	Rated speed [m/s]	Max. speed [m/s]	Magnetic attraction force [N]	Mass of movable element [kg]	Compatible magnet rail model no.	Compatible servo amplifier model no.
DD045CB4AN	800	2200	1.9	3.0	600	8.6	DD045MB□□□□	RS□A10L

Magnet rail model no.	Magnet rail mass (total of 2 rails) [kg]	Dimensions			
		L1	L2	N1	N2
DD045MB064	1.4	64	32	1	2
DD045MB128	2.8	128	96	3	4
DD045MB256	5.5	256	224	7	8
DD045MB512	11.1	512	480	15	16

Thrust-Speed Characteristics

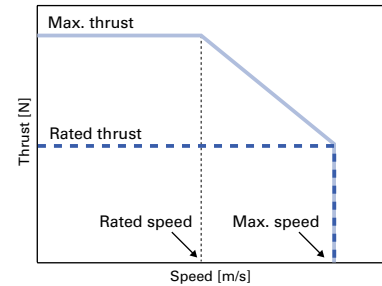

Coil dimensions

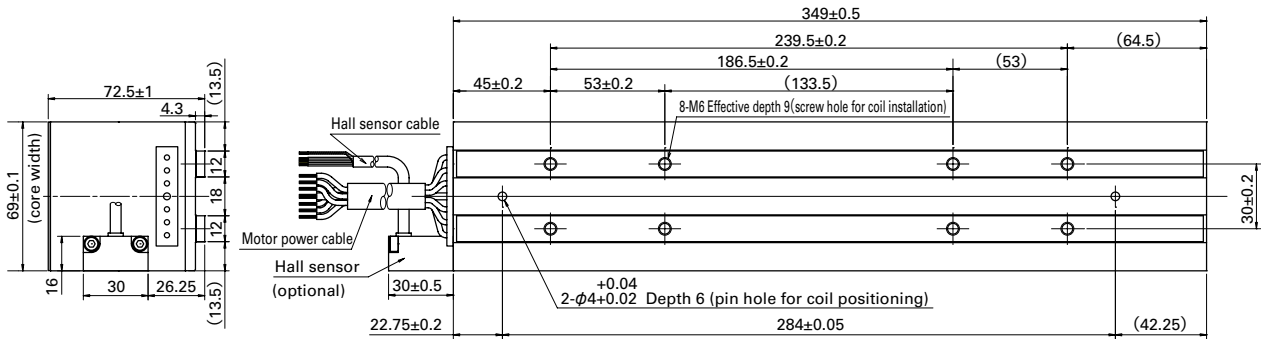

Magnet rail dimensions

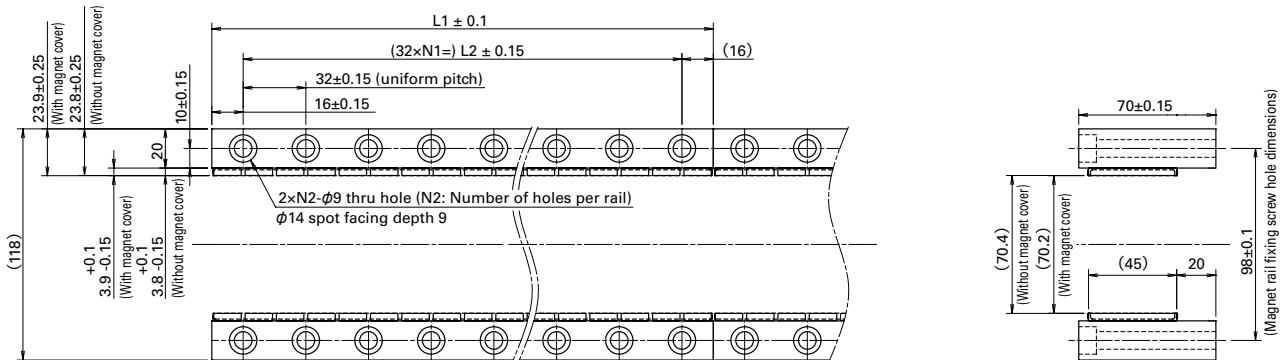
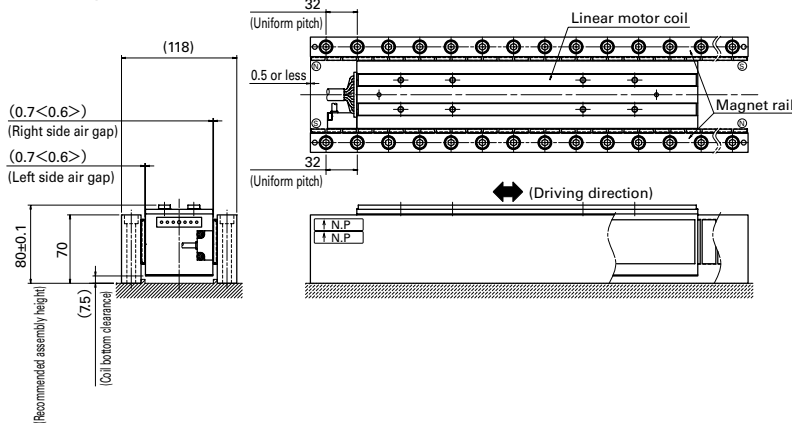
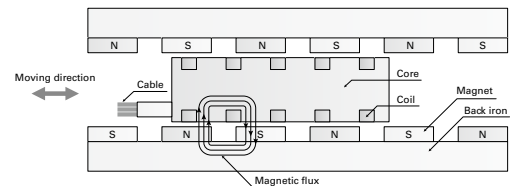

Diagram of recommended assembly example



Motor cross section (top view)



SANMOTION S

Servo Amplifiers and Spindle Motors

Servo Amplifier Capacity: 150 A

A servo system with a servo amplifier and a spindle motor. Ideal for the main shaft of machine tools that require highly precise tapping synchronized with the feed shaft. It improves productivity of the device.



How to read model numbers

Note that not all the possible combinations of the numbers and characters below are valid. Also, some of the numbers/characters listed below are for optional models. For model numbers valid as standard products, refer to "Standard Model Number List".

Servo amplifier

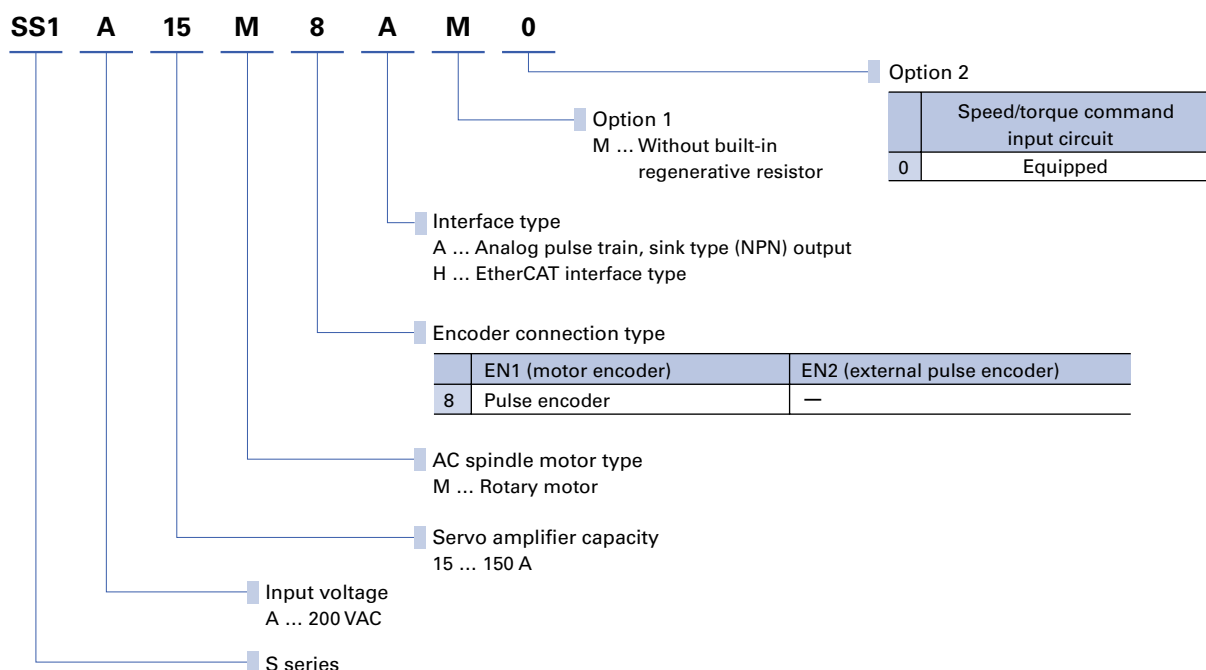

Spindle motor

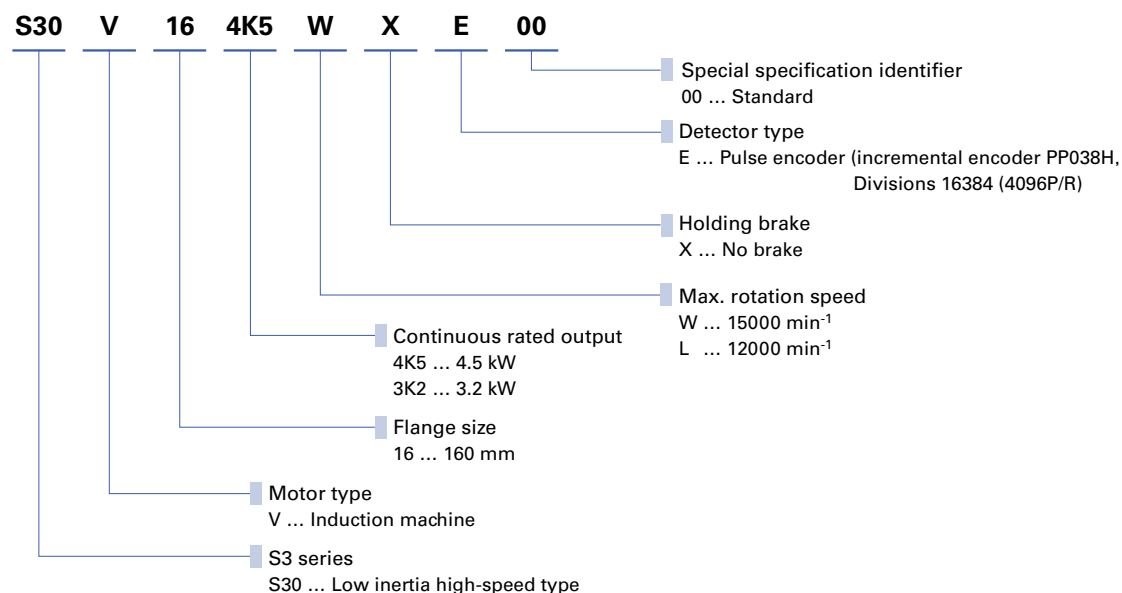

Spindle Motor Specifications

Spindle motor model number				S30V163K2LXE00	S30V164K5WXE00
Servo amplifier model No. to be combined	Analog/pulse input type			SS1A15M8AM0	
	EtherCAT interface type			SS1A15M8HM1	
S1 continuous rated output	★	P_R	kW	3.2	4.5
S2 15 min. rated output	★	P_{15}	kW	5.0	6.5
Max. output	★	P_p	kW	9.6	13.5
Base rotation speed		N_R	min^{-1}	1500	3000
Max. Rotation Speed		N_{max}	min^{-1}	12000	15000
S1 continuous rated torque	★	T_R	$\text{N}\cdot\text{m}$	20.4	14.3
S2 15 min. rated torque	★	T_{15}	$\text{N}\cdot\text{m}$	31.8	20.7
Max. torque	★	T_p	$\text{N}\cdot\text{m}$	61.1	43.0
S1 continuous rated current	★	I_R	Arms	27	32
S2 15 min. rated current	★	I_{15}	Arms	39	41
Max. current	★	I_p	Arms	78	79
Rotor inertia		J_M	$\text{kg}\cdot\text{m}^2(\text{GD}^2/4)$	0.00683	0.00483
Mass		W_E	kg	36	29

Items with ★ indicate values after temperature rise saturation. Other items indicate values when the temperature is 20°C. Also, items with ★ indicate values when used with a standard amplifier. Above values are typical values.

Speed-Output characteristics

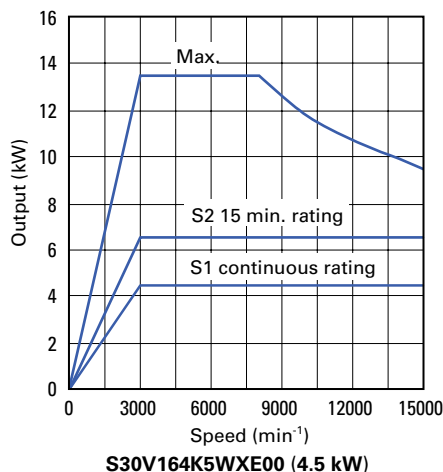
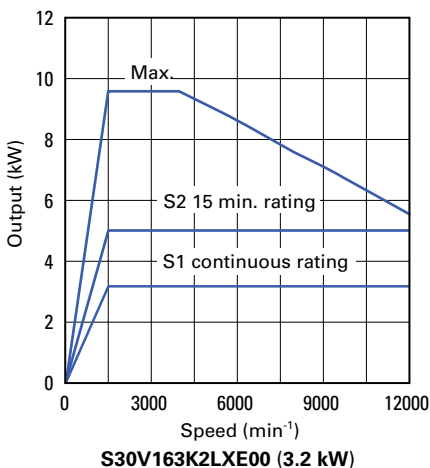

Speed-Torque characteristics

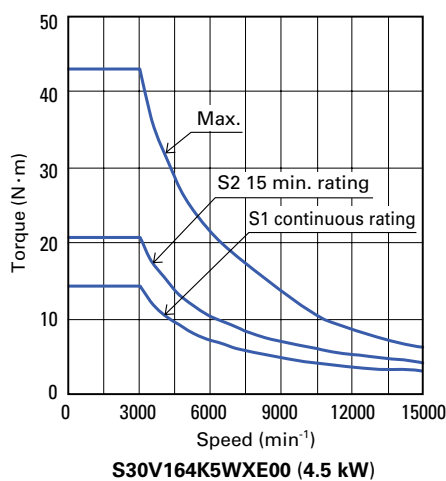
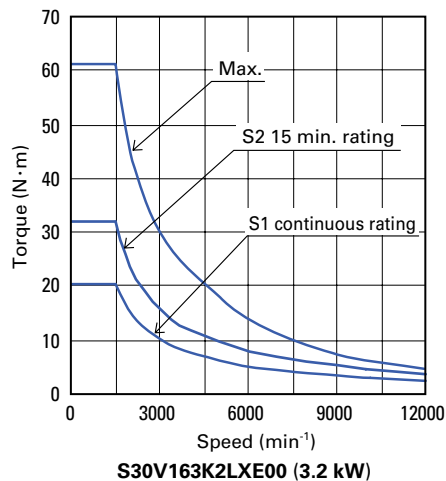

Servo Amplifier Specifications

Model No.	SS1A15M8AM0	SS1A15M8HM1
Interface	Analog/pulse input type	EtherCAT interface type
Power supply voltage	Main circuit power supply: 3-Phase 200 to 230 VAC +10, -15%, 50/60 Hz \pm 3 Hz Control circuit power supply: Single-phase 200 to 230 VAC +10, -15%, 50/60 Hz \pm 3 Hz Power supply voltage should be within the specified range (170 to 253 VAC).	
Amplifier output capacity	150 A	
Applicable motor capacity	3.2, 4.5 kW	
Supported encoders	4096 P/R (A, B, Z phase pulse signal)	
Control function	Position, speed, torque, orientation controls	
Control system	Sinusoidal PWM control	
Speed control range	1:5000 (internal command)	
Frequency characteristics	200 Hz	
Regenerative process circuit	Built in (regenerative resistor mounted externally)	
Sequence signal	8 Input channels, 8 Output channels	6 Input channels, 2 Output channels
Ambient temperature	0 to 55°C	
Standards	UL, CE, RoHS directives	

Dimensions [Unit: mm]

Servo amplifier

150 A Mass: 4.9 kg

Model no.: SS1A15M8AM0
Analog/pulse
input type

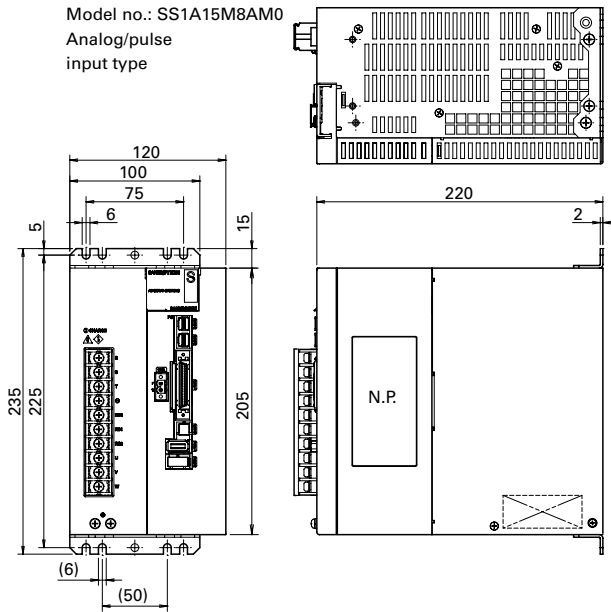

Model no.: SS1A15M8HM1
EtherCAT
interface type

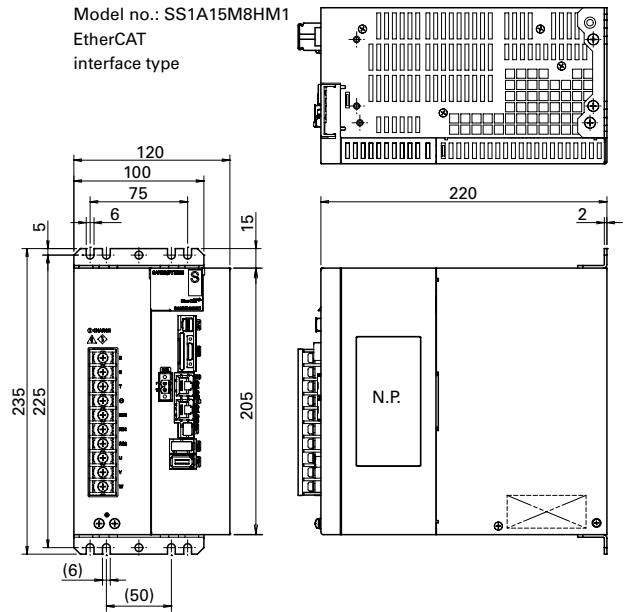

Spindle motor

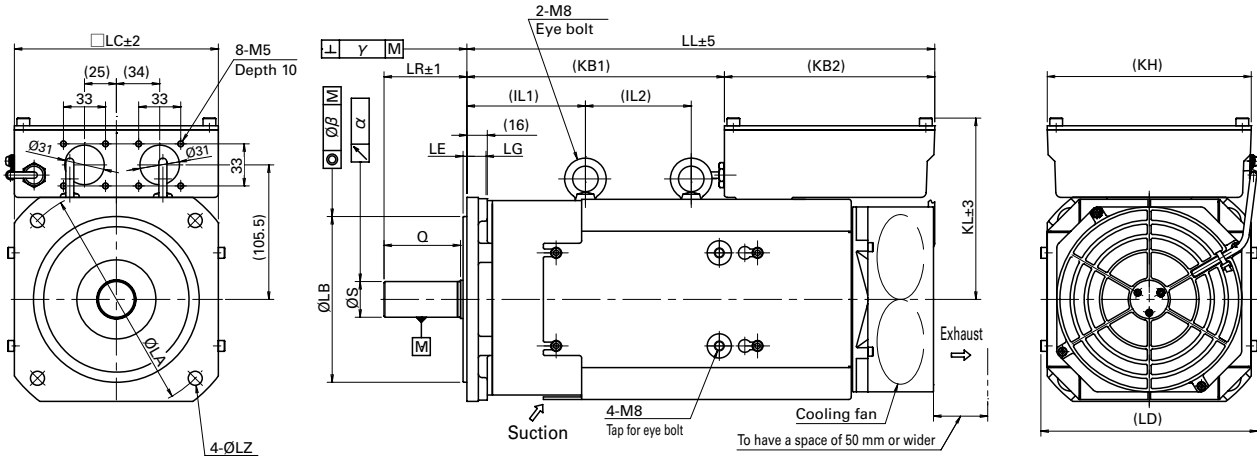

Spindle motor model number	LL	KB2	KL	KH	LG	LA	LB	LE	LC	LZ	LR	LD	S	Q	KB1	IL1	IL2
S30V164K5WXE00	367	165	142	160	15	175	0 130-0.040	3	160	11	65	170	0 28-0.013	60	202	93	83
S30V163K2LXE00	432																

Spindle motor model number	α	β	γ
S30V164K5WXE00	0.01	0.03	0.03
S30V163K2LXE00			

Models No Longer Listed and Their Replacing Models

Models that are no longer listed in catalogs and their replacing models are shown below.

■ Servo amplifier

Models no longer listed		Replacing models (R 3E Model) Used with serial encoder in semi-closed systems
Type	Model no.	Model no.
SANMOTION R 200 V Analog/Pulse Input type	RS1A01AA	RS3A01A0AL0/RS3A02A0AL0
	RS1A03AA	RS3A02A0AL0/RS3A03A0AL0
	RS1A05AA	RS3A05A0AA0
	RS1L01AA	RS3A01A0AA0/RS3A02A0AA0
	RS1L03AA	RS3A02A0AA0/RS3A03A0AA0
	RS1L05AA	RS3A05A0AL0
	RS1A01AB	RS3A01A0BL0/RS3A02A0BL0
	RS1A03AB	RS3A02A0BL0/RS3A03A0BL0
	RS1A05AB	RS3A05A0BA0
	RS1L01AB	RS3A01A0BA0/RS3A02A0BA0
	RS1L03AB	RS3A02A0BA0/RS3A03A0BA0
	RS1L05AB	RS3A05A0BL0
SANMOTION R 100 V Analog/Pulse Input type	RS1N01AA	RS3E01A0AA0/RS3E02A0AA0
	RS1N03AA	RS3E03A0AA0
	RS1E01AA	RS3E01A0AL0/RS3E02A0AL0
	RS1E03AA	RS3E03A0AL0
	RS1N01AB	RS3E01A0BA0/RS3E02A0BA0
	RS1N03AB	RS3E03A0BA0
	RS1E01AB	RS3E01A0BL0/RS3E02A0BL0
	RS1E03AB	RS3E03A0BL0
SANMOTION R ADVANCED MODEL 200 V Analog/Pulse Input type	RS2A01A0AL0	RS3A01A0AL0/RS3A02A0AL0
	RS2A03A0AL0	RS3A02A0AL0/RS3A03A0AL0
	RS2A05A0AL0	RS3A05A0AL0
	RS2A10A0AL0	RS3A10A0AL0
	RS2A15A0AL0	RS3A15A0AL0
	RS2A30A0AL0	RS3A30A0AL0
	RS2A01A0AA0	RS3A01A0AA0/RS3A02A0AA0
	RS2A03A0AA0	RS3A02A0AA0/RS3A03A0AA0
	RS2A05A0AA0	RS3A05A0AA0
	RS2A10A0AA0	RS3A10A0AA0
	RS2A15A0AA0	RS3A15A0AA0
	RS2A01A0BL0	RS3A01A0BL0/RS3A02A0BL0
	RS2A03A0BL0	RS3A02A0BL0/RS3A03A0BL0
	RS2A05A0BL0	RS3A05A0BL0
	RS2A10A0BL0	RS3A10A0BL0
	RS2A15A0BL0	RS3A15A0BL0
	RS2A30A0BL0	RS3A30A0BL0
	RS2A01A0BA0	RS3A01A0BA0/RS3A02A0BA0
	RS2A03A0BA0	RS3A02A0BA0/RS3A03A0BA0
	RS2A05A0BA0	RS3A05A0BA0
RS2A10A0BA0	RS3A10A0BA0	
RS2A15A0BA0	RS3A15A0BA0	
SANMOTION R ADVANCED MODEL 100 V Analog/Pulse Input type	RS2E01A0AL0	RS3E01A0AL0/RS3E02A0AL0
	RS2E03A0AL0	RS3E03A0AL0
	RS2E01A0AA0	RS3E01A0AA0/RS3E02A0AA0
	RS2E03A0AA0	RS3E03A0AA0
	RS2E01A0BL0	RS3E01A0BL0/RS3E02A0BL0
	RS2E03A0BL0	RS3E03A0BL0
	RS2E01A0BA0	RS3E01A0BA0/RS3E02A0BA0
	RS2E03A0BA0	RS3E03A0BA0

* Some models that are no longer listed use the same hardware depending on the motor encoder and external encoder that are used together, however, the product model numbers of the replacing models vary with the motor encoder and external encoder that are used together.

* For model numbers of the R 3E Model servo amplifiers (replacement of SANMOTION R servo amplifiers (model no. starts with RS1)) which use a wire-saving incremental encoder as a motor encoder or used in full-closed systems, contact us.

Servo Motor Capacity Selection (Rotary Motor)

This is a method of calculating the required capacity of servo motors from the mechanical specifications. Here we have introduced the basic selection procedure focusing on a ball screw (flat) mechanism.

Selection procedure

1. Creation of operation patterns

Create the operation patterns.

2. Calculation of conversion of motor shaft moment of load inertia J_L

Calculate the moment of load inertia from the machine configuration.

3. Calculation of load torque T_L for motor shaft conversion

Calculate the load torque from the machine configuration.

4. Provisional selection of servo motor capacity

Provisionally select a motor in which the load moment of inertia (J_L) is 10 times or less than the rotor moment of inertia (J_M) of servo motor, while the load torque (T_L) is 80% or less ($T_R \times 0.8$) of rated torque of motor (T_R).

$$J_L \leq J_M \times 10$$

$$T_L \leq T_R \times 0.8$$

5. Calculation of acceleration/deceleration torque

Calculate the required acceleration/deceleration torque from the operation patterns.

6. Calculation of effective torque

Calculate the effective torque from the torque patterns.

7. Judgment

Determine whether the acceleration and deceleration torque (T_a, T_b) are 80% ($T_p \times 0.8$) or less than the peak stall torque (T_p) of the servo motor; and the effective torque (T_{rms}) is 80% ($T_R \times 0.8$) or less than the rated torque (T_R) of the servo motor.

$$T_a \leq T_p \times 0.8$$

$$T_b \leq T_p \times 0.8$$

$$T_{rms} \leq T_R \times 0.8$$

If the judgment results cannot be applied in the aforementioned equation, reconsider the servo motor capacity, for example increasing the capacity.

8. Calculation of regenerative power

Calculate the regenerative power and select an external regenerative resistor if necessary.

1. Creation of operation patterns

First, determine the equipment mechanism, dimensions of all parts, positioning amount, positioning time, gear ratio, etc. An operation pattern is the determined driving force plotted on the speed/time axis.

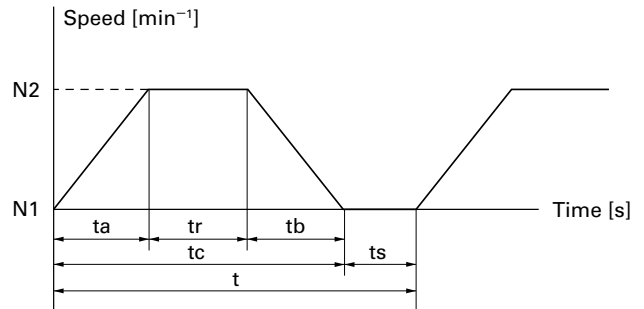

t_a = Acceleration time [s]

t_b = Deceleration time [s]

t_r = Constant speed-time [s]

t_s = Downtime [s]

t = 1 cycle [s]

2. Calculation of conversion of motor shaft moment of load inertia J_L

Load moment of inertia is the quantity showing inertia of a rotating object.

Given below is the calculation method used in case of ball screw (flat) mechanism.

■ Ball screw moment of inertia

$$J_{L1} = \left(\frac{1}{G}\right)^2 \times \frac{\pi \times \rho \times D^4 \times L}{32} \quad [\text{kg}\cdot\text{m}^2]$$

G: Gear ratio

ρ : Ball screw specific gravity [kg/m^3] [Iron: 7.8×10^3]

D: Ball screw diameter [m]

L: Ball screw length [m]

■ Work + table moment of inertia

$$J_{L2} = \left(\frac{1}{G}\right)^2 \times W \times \left(\frac{P}{2\pi}\right)^2 \quad [\text{kg}\cdot\text{m}^2]$$

G: Gear ratio

W: Work + table mass [kg]

P: Ball screw pitch [m]

■ Conversion of motor shaft moment of load inertia.

$$J_L = J_{L1} + J_{L2}$$

* Moments of inertia of reducer and coupling are assumed to be negligible and have therefore been omitted.

Servo Motor Capacity Selection (Rotary Motor)

3. Calculation of load torque T_L for motor shaft conversion

Load torque is the power generated from the friction of the driving part or from the gravity that is converted on the motor shaft. When activated, this torque always acts as the load.

Given below is the calculation method used in the case of a ball screw (flat) mechanism.

$$T_L = \frac{(F + \mu W)}{\eta} \times \frac{P}{2\pi} \times \frac{1}{G} \times 9.8 \quad [\text{N}\cdot\text{m}]$$

- F: External force [kg]
- η : Machine efficiency
- μ : Coefficient of friction
- W: Work + table mass [kg]
- P: Ball screw lead [m]
- G: Gear ratio

4. Provisional selection of servo motor capacity

Provisionally select the motors that apply to the following 2 conditions.

- Load moment of inertia (J_L) calculated in step 2 is 10 times or less than the rotor moment of inertia (J_M) of servo motor

$$J_L \leq J_M \times 10$$

- Load torque (T_L) calculated in step 3 is 80% or less ($T_R \times 0.8$) of rated torque (T_R) of servo motor

$$T_L \leq T_R \times 0.8$$

5. Calculation of acceleration/deceleration torque

Acceleration/deceleration torque is necessary for accelerating and decelerating the motor and load.

■ Method of obtaining acceleration torque (T_a)

$$T_a = \frac{2\pi(N_2 - N_1) \times (J_L + J_M)}{60 \times t_a} + T_L \quad [\text{N}\cdot\text{m}]$$

- N_2 : Servo motor rotary speed after acceleration [min^{-1}]
- N_1 : Servo motor rotary speed before acceleration [min^{-1}]
- J_L : Conversion of motor shaft moment of load inertia [$\text{kg}\cdot\text{m}^2$]
- J_M : Conversion of servo motor moment of rotor inertia [$\text{kg}\cdot\text{m}^2$]
- T_L : Calculation of load torque for motor shaft conversion [$\text{N}\cdot\text{m}$]
- t_a : Acceleration time [s]

■ Method of obtaining deceleration torque (T_b)

$$T_b = \frac{2\pi(N_2 - N_1) \times (J_L + J_M)}{60 \times t_b} - T_L \quad [\text{N}\cdot\text{m}]$$

- N_2 : Servo motor rotary speed before deceleration [min^{-1}]
- N_1 : Servo motor rotary speed after deceleration [min^{-1}]
- J_L : Conversion of motor shaft moment of load inertia [$\text{kg}\cdot\text{m}^2$]
- J_M : Conversion of servo motor moment of rotor inertia [$\text{kg}\cdot\text{m}^2$]
- T_L : Calculation of load torque for motor shaft conversion [$\text{N}\cdot\text{m}$]
- t_b : Deceleration time [s]

6. Calculation of effective torque

Effective torque is the value per unit time obtained from root mean square of load torque / acceleration torque / deceleration torque .

$$T_{rms} = \sqrt{\frac{(T_a^2 \times t_a) + (T_L^2 \times t_r) + (T_b^2 \times t_b)}{t}} \quad [\text{N}\cdot\text{m}]$$

7. Judgment

Our company's judgment criteria are as follows.

- Load torque load factor $T_L \leq T_R \times 0.8$
(Load torque is 80% or less of rated torque)
- Acceleration torque load factor $T_a \leq T_p \times 0.8$
(Acceleration torque is 80% or less of peak stall torque)
 T_p : Peak stall torque
- Deceleration torque load factor $T_b \leq T_p \times 0.8$
(Deceleration torque is 80% or less of peak torque at stall)
 T_p : Peak stall torque
- Effective torque load factor $T_{rms} \leq T_R \times 0.8$
(Effective torque is 80% less than rated torque)
- Moment of inertia ratio $J_L \leq J_M \times 10$
(Load moment of inertia is 10 times or less than the rotor moment of inertia of motor)

Rise in motor temperature can be suppressed by keeping a large margin in torque load factor. The moment of inertia ratio can be controlled at 10 times or more, for example, by slowly rotating the table mechanism. Testing with an actual machine is recommended.

8. Calculation of regenerative power

Calculate the regenerative efficient power (PM) to determine the regenerative resistor to be used. From the calculation results, determine whether a built-in regenerative resistor can be used.

■ Method of obtaining regenerative efficient power (PM) of horizontal drive shaft

Derive the regenerative energy.

$$EM = Ehb = \frac{1}{2} \times N \times 3 \times Ke \phi \times \frac{T_b}{KT} \times t_b - \left(\frac{T_b}{KT} \right)^2 \times 3 \times R \phi \times t_b$$

- EM: Regenerative energy in case of horizontal drive shaft [J]
- Ehb: Regenerative energy during deceleration [J]
- $Ke \phi$: Induced voltage constant [$\text{Vrms}/\text{min}^{-1}$] (motor constant)
- KT: Torque constant [$\text{N}\cdot\text{m}/\text{Arms}$] (motor constant)
- N: Motor rotary speed [min^{-1}]
- $R \phi$: Armature resistance [Ω] (motor constant)
- t_b : Deceleration time [s]
- T_b : Deceleration torque [$\text{N}\cdot\text{m}$]

Derive the regenerative efficient power from regenerative energy.

$$PM = \frac{EM}{t}$$

- PM: Regenerative efficient power [W]
- EM: Regenerative energy [J]
- t: Cycle time [s]

■ Selection of regenerative resistor

Select a regenerative resistor that meets the following conditions.

- In case of servo amplifiers with a built-in regenerative resistor:
Permissible regenerative power [PR] that is less than efficient regenerative power [PM] and can be used with built-in regenerative resistors
- In case of external regenerative resistor:
Permissible regenerative power [PRO] that is less than efficient regenerative power [PM] and can be used with external regenerative resistors

Note that we have servo amplifier models both with and without built-in regenerative resistors for absorbing regenerative power. Select the model accordingly.

Selection Data for Each Mechanism

Typical examples of mechanisms and items that require selection are shown below. Provide this information when placing an order.

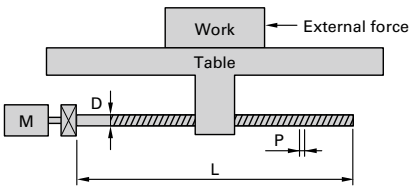
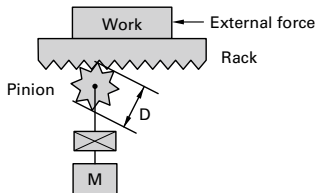
Ball screw			Rack & pinion				
							
External force	F		N	External force	F		N
W: Work + table mass	W		kg	Work + rack mass	W		kg
Ball screw diameter	D		m	Pinion diameter	D		m
Ball screw length	L		m	Pinion thickness	L		m
Ball screw lead	P		m	Pinion material specific gravity	ρ		kg/m ³
Ball screw material specific gravity	ρ		kg/m ³	Coefficient of friction	μ		
Coefficient of friction	μ			Gear ratio *	G		
Gear ratio *	G			Machine efficiency	η		
Machine efficiency	η						

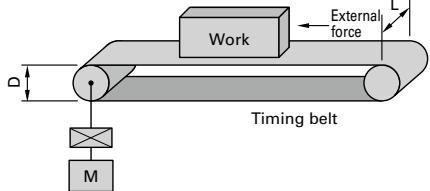
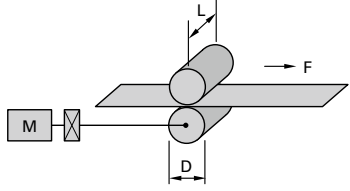
Belt drive			Roll feed				
							
External force	F		N	Sheet tension	F		N
Work + belt mass	W		kg	Roll diameter	D		m
Pulley diameter	D		m	Roll width	L		m
Pulley width	L		m	Roll material specific gravity	ρ		kg/m ³
Pulley material specific gravity	ρ		kg/m ³	Roll moment of inertia	J		kg·m ²
Pulley moment of inertia	J		kg·m ²	Gear ratio *	G		
Gear ratio *	G			Machine efficiency	η		
Machine efficiency	η						

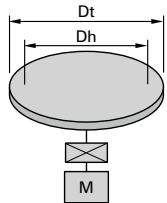
Rotary table			
			
Table mass	W		kg
Table diameter	Dt		m
Table support diameter	Dh		m
Table moment of inertia	J		kg·m ²
Support part coefficient of friction	μ		
Gear ratio *	G		
Machine efficiency	η		

* Derivation of gear ratio (G)

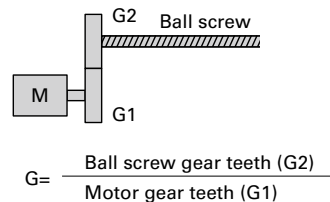

Safety Precautions

The products in this catalog are designed to be used with general industrial devices. When using them, pay sufficient attention to the following points.

- Read the Instruction Manual thoroughly prior to installation, assembly and/or operation in order to use the product properly.
- Refrain from modifying or processing the product in any way.
- Contact your dealer or professionals for installation or maintenance services of the product.
- Regarding the following uses of the product, contact us for the special care required for operation, maintenance and management such as multiplexing the system, installing an emergency electric generator set, and so forth.

- ① Use in medical equipment that may have an effect on human life
- ② Use in equipment such as trains or elevators, that may have an effect on human life or the human body
- ③ Use in computer systems that may have a major impact on society or on the public
- ④ Use in other devices that have a major impact on maintaining equipment and device functions that may have an effect on human safety or public operations.

- In addition to the above, contact us for use in an environment where vibrations occur, such as in automobiles or while being transported.
- Familiarize yourself with the equipment, safety information, and precautions before using the product.

Indication by (Warning Label) on the Product

The following indications are expressed by Warning labels. Indications vary depending on models.



This label is affixed near high voltage parts such as the electrically charged or cover-protected section, warning of the places where it is likely to cause an electric shock.



This label is affixed near the GND terminals where grounding is required, recommending that the terminals should be well grounded.

Safety Ranks of the Cautions

The following five ranks are provided.



DANGER Improper operations or use is most likely to result in serious injury or death.



WARNING Improper operations or use is most likely to result in serious injury or death.



CAUTION Improper operations or use is likely to result in average or minor injury, or in property damage.

In spite of the cautions with the **CAUTION** label, it may cause serious results. Either the contents or the labels is describing important cautions to be followed inevitably.



PROHIBITED Indicates what must not be done.



COMPULSORY Indicates what must be done.

WARNING

Precautions on Use

1. Do not use the product in an explosive atmosphere. Doing so may cause injury or fire.
2. Do not work on wiring, maintenance servicing or inspection with the electric power on. Always turn the power off and wait for 15 minutes or more. Confirm that the main circuit power supply charging LED is off before starting the work. Failure to do so may result in an electric shock or damage.
3. The protective ground terminal of the servo amplifier must be grounded to the device or control panel. The servo motor ground terminal must be connected to the protective ground terminal of the servo amplifier. Failure to do so may result in an electric shock.
4. Never touch the internal parts of the servo amplifier. Doing so may cause an electric shock.

5. Do not damage, apply excessive stress, or place a heavy object on the cable or get it caught between objects. Doing so may cause an electric shock.
6. Never touch the rotating part of the servo motor during its operation. Doing so may cause injury.

CAUTION

Precautions on Use

1. Use the servo amplifier and servo motor in the designated combination. Failure to do so may result in a fire or failure.
2. Have a person with specialized knowledge perform transporting, installation, wiring, operation, maintenance or inspection of the product. Failure to do so may result in an electric shock, injury or fire.
3. Do not install the product in a damp environment, explosive, flammable or corrosive atmosphere, or near a combustible material. Doing so may cause a fire or failure.

4. Do not touch the servo amplifier, servo motor or peripheral devices as the temperature becomes very high. Doing so may cause burns.
5. Do not touch the product while the power is on or for a while after the power is turned off since the servo amplifier radiator fins, regenerative resistor, and servo motor are very hot. Doing so may cause burns.
6. Have a person with specialized knowledge of relevant safety standards read and understand the information listed in the included Instruction Manual before designing the safety system that uses the Safe Torque Off function. Failure to do so may result in injury or failure.
7. Prior to installation, operation, maintenance servicing or inspection, be sure to read the Instruction Manual and follow the instructions to perform. Failure to do so may result in an electric shock, injury or fire.
8. Use the servo amplifier and servo motor within the specified ranges. Failure to do so may result in an electric shock, injury, or damage.
9. Element wires of the regenerative resistor have an allowed instantaneous capacity. Consult us if the moment of inertia is large or rotational speed is high and the instantaneous regenerative current is large.

Transportation

10. Do not carry the product by holding the cable, motor spindle, or detector section. Doing so may cause a failure or injury.
11. Be careful when carrying the product to prevent it from falling or overturning. Failure to do so may result in injury.

Placement

12. Do not climb on or place a heavy object on the product. Doing so may cause injury.
13. Ensure that the product is installed in the correct direction. Failure to do so may result in a fire or failure.
14. Do not drop or expose the product to excessive shock. Doing so may cause a failure.
15. Ensure that the intake and exhaust ports are not blocked and take measures to prevent foreign matter from entering. Failure to do so may result in a fire.
16. Place the servo amplifier in the control panel keeping a distance from other devices as instructed in the Instruction Manual. Failure to do so may result in a fire or failure.
17. Ensure that the bottom and top of the box are facing correctly while unpacking. Failure to do so may result in injury.
18. Confirm that the product is what you ordered. Failure to do so may result in injury or damage.
19. Be careful when installing the product in order to prevent it from falling or overturning. Use eye bolts for servo motors that come with them. Failure to do so may result in injury.
20. Mount the product on an incombustible material such as metal. Failure to do so may result in a fire.
21. Setup devices such as a collision safety device so that it sufficiently withstands the maximum output of the system. Failure to do so may result in injury.

Wiring

22. Ensure that wiring has been correctly done. Failure to do so may result in injury.
23. Perform wiring as instructed in the wiring diagram or the Instruction Manual. Failure to do so may result in an electric shock or fire.
24. Perform wiring conforming to the electrical Installation standards or the internal rule. Failure to do so may result in burnout or fire.
25. Do not connect commercial power supplies to U, V, W terminals of the servo motor. Doing so may cause a fire or failure.
26. Install safety devices such as a breaker to prepare for a short circuit of external wiring. Failure to do so may result in a fire.
27. Do not bind the servo motor power cable and I/O signal cable or encoder cable together or pass them through the same duct. Doing so may cause a malfunction.
28. When connecting an inductive load such as a relay to the control output signal of the servo amplifier, always connect a diode for surge absorption. Make sure that the diode is connected in the correct polarity direction. Failure to do so may result in a failure of the servo amplifier.
29. Do not connect 90 VDC or AC power to the servo motor 24 VDC brake. Also, do not connect 400 VAC to the servo motor 200 VAC cooling fan. Doing so may cause burnout or fire.
30. Braking delay time becomes longer due to the surge absorption

element for the servo motor holding brake relay. Use a sequence that takes the holding delay time into consideration. Failure to do so may result in fall or injury.

Operations

31. Do not make drastic changes or adjustments as they may result in unstable operation. Doing so may cause injury.
32. When performing a trial operation, fasten the servo motor and disconnect it from the mechanical system. Check the operation, then connect it to the machine. Failure to do so may result in injury.
33. The holding brake is not a stopping device to ensure machine safety. Install a stopping device on the machine to ensure machine safety. Failure to do so may result in injury.
34. When an alarm has been activated, eliminate the cause, ensure safety, and reset the alarm before resuming operations. Failure to do so may result in injury.
35. Ensure that the input power supply voltage is within the specified range. Failure to do so may result in a failure.
36. When the electric power recovers after a momentary interruption, do not approach the devices because the system may restart operation by itself. (Design the system ensuring safety in case it restarts on such occasions.) Doing so may cause injury.
37. Do not use servo amplifiers and servo motors that have had a failure, damage, or burnout. Doing so may cause injury or fire.
38. Stop operations immediately when an emergency occurs. Failure to do so may result in an electric shock, injury or fire.
39. When using the servo motor with a vertical axis, install a safety device to prevent the workpiece from falling when an alarm is activated. Failure to do so may result in injury or damage.

Maintenance and Inspection

40. Parts that are used in servo amplifiers (electrolytic condenser, cooling fan, lithium batteries for the encoder, fuse, relay, etc.) deteriorate over time. As preventive maintenance, replace with new ones according to the standard replacement intervals. Contact us for details. Failure to do so may result in a failure.
41. Never touch the terminals or connectors while the power is on. Doing so may cause an electric shock.
42. Servo amplifier frames become very hot. Be careful when performing maintenance or inspection. Failure to do so may result in burns.
43. Contact us for repairs. If the product is disassembled by the user, it may become inoperable. Doing so may cause a failure.



Storage

1. Avoid storing this product in places exposed to rain or water drops, or in an environment with hazardous gas or liquid. Failure to do so may result in a failure.

Operations

2. Do not use the brake built into the servo motor for normal braking operation as it is a holding brake. Using this brake for braking damages the brake. Doing so may cause a failure.
3. Do not apply static electricity or high voltage to the encoder cable for the servo motor. Doing so may cause a failure.
4. With a servo amplifier that has a standard dynamic brake resistor, never continuously rotate the servo motor externally when the servo is off. Doing so causes the dynamic brake resistor to generate heat, which is very dangerous. Doing so may cause a fire or burns.
5. Applying excessive voltage that exceeds the input voltage range may cause a part failure. Never use the product with the voltage exceeding the specified range. Doing so may cause a failure or injury.
6. Do not turn on and off the power frequently. Turning on and off the power exceeding 30 times/day, 5 times/hour may cause premature failures of internal parts.

Maintenance and Inspection

7. Do not disassemble or repair the product. Doing so may cause fire or an electric shock.
8. Do not measure the insulation resistance or dielectric voltage of the product. Doing so may cause damage.
9. Never plug in or unplug a connector with the power ON (hot swapping) as electronic components may be damaged due to the generated surge voltage. Doing so may cause an electric shock or damage.
10. Do not remove the nameplate.

Storage

1. Avoid direct sunlight and store the product within the specified ambient temperature and humidity range “-20°C to +65°C, 90% RH or less” (non-condensing). Failure to do so may cause a failure.
2. If the servo amplifier has been stored for a long period (3 years or longer as a general guide), contact us. The capacitance may have decreased with the electrolytic condenser due to the long period storage, which may cause a failure.
3. If the servo motor has been stored for a long period (3 years or longer as a general guide), contact us. Bearings and brakes must be checked.

Transportation

4. Excess loading of products on the carrier may cause the load to collapse. Follow the instructions given on the outside of the package. Failure to do so may result in injury.
5. Use eye bolts that come with servo motors to transport servo motors. Do not use them to transport devices. Doing so may cause injury or failure.

Wiring

6. Install an external emergency stop circuit to turn the power off in the event that operation must be instantly halted. Also, build a safety circuit outside of the servo amplifier so that the main

circuit power supply is turned off when an alarm is activated. Failure to do so may result in uncontrollable operation, injury, fire, or secondary damage.

Operations

7. Install an external emergency stop circuit to turn the power off in the event that operation must be instantly halted. Also, build a safety circuit outside of the servo amplifier so that the main circuit power supply is turned off when an alarm is activated. Failure to do so may result in uncontrollable operation, injury, fire, or secondary damage.
8. Servo motors are not equipped with any protective devices. Take protective measures using an over-current protective relay, a ground fault interrupter, a protective device from excess temperature, and an emergency stopping device. Failure to do so may result in injury or fire.
9. Operate this product within the specified ambient temperature and humidity range.
 Servo amplifier (temperature 0°C to 55°C/Humidity 90%RH or less (non-condensing))
 Servo motor (temperature 0°C to 40°C/Humidity 90%RH or less (non-condensing))
 Failure to do so may result in a failure.

Retirement

10. When disposing of a servo amplifier or servo motor, handle it as general industrial waste.

Guideline for Suppressing Harmonics

Harmonic current generated from devices such as a servo amplifier may affect other customers if emitted. Therefore, “Guideline for Suppressing Harmonics by Customers Receiving High Voltage or Special High Voltage” is established by the Ministry of International Trade and Industry (currently Ministry of Economy).

Servo amplifiers used by specific customers are the target devices (harmonics generator) of this guideline. Consumers to whom the guideline is applied must determine if harmonic suppression measures are necessary based on the guideline and take measures for keeping harmonic emission within the limit specified by the contracted power. Even for consumers to whom the guideline is not applied, it is recommended to take harmonic suppression measures in order to avoid troubles due to the harmonics.

Our servo amplifiers fall under the circuit type in the table 1 shown in the “Guideline for Suppressing Harmonics”.

Refer to the following materials for information on how to calculate harmonic current.

“Harmonic current calculation method for specific customers” (JEM-TR225) General Incorporated Association The Japan Electrical Manufacturers’ Association (JEMA)

For servo amplifiers that have DC type input power supply, determine if harmonic suppression measures are necessary on the converter (AC-DC converter) side.

When harmonic suppression measures are necessary for the servo amplifier, connect a harmonic suppression reactor. For harmonic suppression reactors, contact us for details.

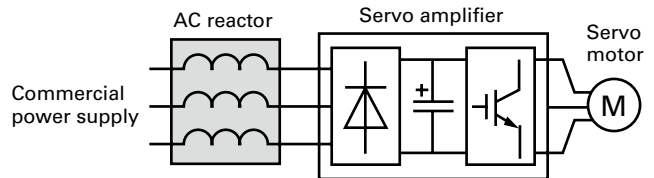

Table 1

Servo amplifier model no.	Power supply	Circuit classification	Circuit type		Conversion factor Ki	
RS3□01□□ RS3□02□□ RS3□03□□ RS3□05□□	3-Phase	3	3-Phase bridge (Condenser smooth)	3-1	6-pulse converter without reactor	K31=3.4
				3-2	6-pulse converter with reactor (AC side)	K32=1.8
	Single-phase	4	Single-phase bridge (Condenser smooth, full-wave rectification)	4-3	Without reactor	K43=2.9
				4-4	With reactor (AC side)	K44=1.3
RS3A10□□ RS3A15□□ RS3A30□□	3-Phase	3	3-Phase bridge (Condenser smooth)	3-1	6-pulse converter without reactor	K31=3.4
				3-2	6-pulse converter with reactor (AC side)	K32=1.8
RS3PAA27000 (Power supply unit for RS3W60□□)						

Reference materials
“Guideline for Suppressing Harmonics by Customers Receiving High Voltage or Special High Voltage” (September, 1994) Ministry of International Trade and Industry (currently Ministry of Economy) “Guideline for Suppressing Harmonics” (JEAG 9702-2013) General Incorporated Association The Japan Electric Association “Guideline for Suppressing Servo Amplifier Harmonics” (February, 2015) General Incorporated Association The Japan Electrical Manufacturers’ Association (JEMA) “Harmonic current calculation method for specific customers” (JEM-TR225) General Incorporated Association The Japan Electrical Manufacturers’ Association (JEMA) “Guideline for Suppressing Servo Amplifier (input current 20 A or less) Harmonics” (JEM-TR227) General Incorporated Association The Japan Electrical Manufacturers’ Association (JEMA)



■ Motion controller



SANMOTION C
MOTION CONTROLLER

- GA1060** Reduction of wires by networking with the serial I/F
- SERCOS** Motion control, robot control, and sequence control
- CANopen**



- EtherCAT** EtherCAT interface type as standard feature
- GA1060** Motion control, robot control, and sequence control

■ AC servo system



SANMOTION R 3E Model
AC SERVO SYSTEMS

- Safety function mounted** Input voltage: 100, 200 VAC
- Analog/Pulse** Motor flange size: 40 to 275 mm
Output capacity: 30 W to 30 kW



SANMOTION R ADVANCED MODEL
AC SERVO SYSTEMS

- Safety function mounted** Input voltage: 100, 200 VAC
- EtherCAT** Motor flange size: 40 to 220 mm
Output capacity: 30 W to 15 kW

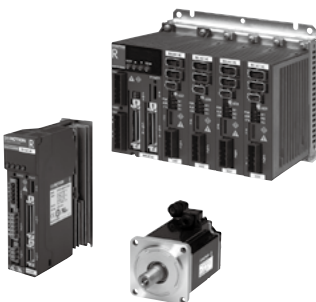

SANMOTION R
AC SERVO SYSTEMS

- Single axis** Input voltage: 100, 200 VAC
- Built-in positioning function** Motor flange size: 40 to 220 mm
Output capacity: 30 W to 15 kW
- CANopen**
- Multi-axis**
- Pulse**

■ AC servo system



SANMOTION R *ADVANCED MODEL*
AC SERVO SYSTEMS

- Single axis
 - Pulse
 - EtherCAT
- Multi-axis
 - EtherCAT

Input voltage: 48 VDC
 Motor flange: 20 to 60 mm
 Output capacity: 20 to 200 W



Compact AC servo motor

Motor flange size: 14 mm
 Output capacity: 2.4 W

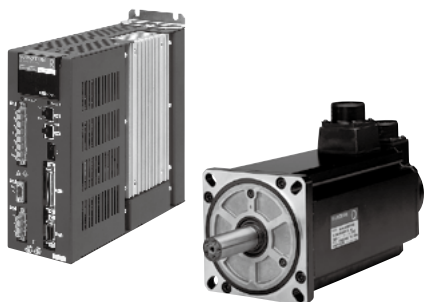

SANMOTION
AC SERVO SYSTEMS

- Analog/Pulse
- CANopen

Input voltage: 400 VAC
 Motor flange size: 86 to 220 mm
 Output capacity: 500 W to 20 kW

■ AC spindle motor, AC servo amplifier

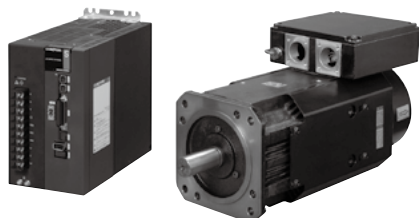

SANMOTION S
AC SERVO SYSTEMS

- Analog/Pulse
- EtherCAT

Input voltage: 200 VAC
 Motor flange size: 160 mm
 Output capacity: 3.2, 4.5 kW

■ DC servo system



SANMOTION T
DC SERVO SYSTEMS

- Analog/Pulse

Input voltage: 50, 140 VDC
 Motor size: ϕ 41 to ϕ 87.5 mm
 Rated output: 23 to 500 W

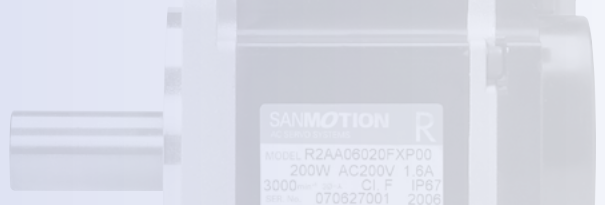

■ Closed-loop stepping system



SANMOTION Model No. PB

Pulse
RS-485
Parallel I/O
EtherCAT

Driver: AC input/DC input, single axis/multi axes
 Motor size: 28 to 86 mm
 With gear and brake

■ 5-Phase stepping system

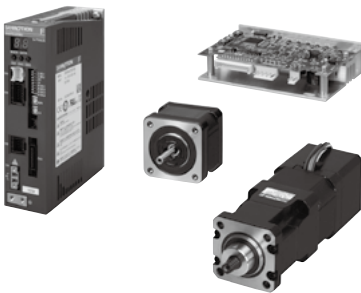

SANMOTION F5

5-PHASE STEPPING SYSTEMS

Micro step
Pulse

Driver: AC input/DC input
 Motor size: 28 to 86 mm
 With gear and brake

Linear drive stepping motor

Motor size: 42, 60 mm
 With brake, without brake

■ 2-Phase stepping system

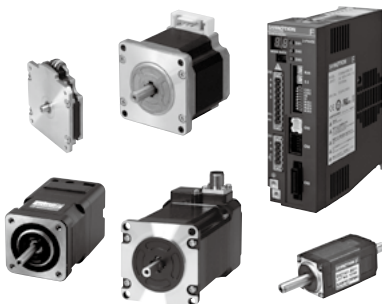

SANMOTION F2

2-PHASE STEPPING SYSTEMS

Micro step
Pulse

Driver: AC input/DC input
 Motor size: 14 to 86 mm, ϕ 80 to 106 mm
 With gear and brake

Driver-integrated stepping motor

Pulse
RS-485
I/O

Driver: 24 VDC
 Motor size: 42, 60 mm

Protection code IP65 stepping motor

Motor size: 56, 86 mm

■ 3-Phase stepping motor

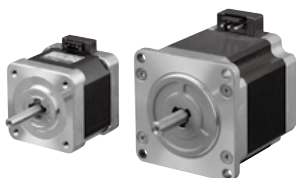

SANMOTION F3

3-PHASE STEPPING MOTOR

Motor size: 42 to 60 mm

■ Linear servo system

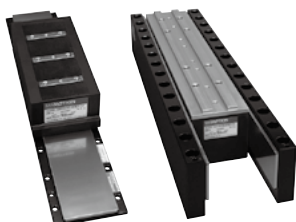

SANMOTION

LINEAR SERVO SYSTEMS

Linear servo motor

Flat type with core, Dual magnet type with core
 Compact cylinder

■ Precautions For Adoption

Failure to follow the precautions on the right may cause moderate injury and property damage, or in some circumstances, could lead to a serious accident.

Always follow all listed precautions.

Cautions

- Read the accompanying Instruction Manual carefully prior to using the product.
- If applying to medical devices and other equipment affecting people's lives, please contact us beforehand and take appropriate safety measures.
- If applying to equipment that can have significant effects on society and the general public, please contact us beforehand.
- Do not use this product in an environment where vibration is present, such as in a moving vehicle or shipping vessel.
- Do not perform any retrofitting, re-engineering, or modification to this equipment.
- The products presented in this catalog are meant to be used for general industrial applications. If using for special applications related to aviation and space, nuclear power, electric power, submarine repeaters, etc., please contact us beforehand.

*For any question or inquiry regarding the above, contact our Sales Department.

<https://www.sanyodenki.com>

SANYO DENKI CO., LTD.

3-33-1 Minami-Otsuka, Toshima-ku, Tokyo 170-8451, Japan

TEL: +81 3 5927 1020

SANYO DENKI EUROPE SA.

P.A. Paris Nord II, 48 Allée des Erables-VILLEPINTE, BP.57286, F-95958 ROISSY CDG Cedex, France

TEL: +33 1 48 63 26 61

SANYO DENKI AMERICA, INC.

468 Amapola Avenue Torrance, CA 90501, U.S.A.

TEL: +1 310 783 5400

SANYO DENKI SHANGHAI CO., LTD.

Room 2106-2110, Bldg A, Far East International Plaza, No.319, Xianxia Road, Shanghai, 200051, China

TEL: +86 21 6235 1107

Beijing Branch

Room1222, Tower B, Beijing COFCO Plaza, No.8 Jianguomennei Dajie, Dong Cheng District, Beijing 100005 China

TEL: +86 10 6522 2160

SANYO DENKI (H.K.) CO., LIMITED

Room 2305, 23/F, South Tower, Concordia Plaza, 1 Science Museum Road, TST East, Kowloon, Hong Kong

TEL: +852 2312 6250

SANYO DENKI TAIWAN CO., LTD.

N-711, 7F, Chia Hsin 2nd Bldg., No.96, Sec.2, Zhongshan N. Rd., Taipei 10449, Taiwan (R.O.C.)

TEL: +886 2 2511 3938

SANYO DENKI SINGAPORE PTE. LTD.

988 Toa Payoh North, #04-08, Singapore 319002

TEL: +65 6223 1071

Indonesia Representative Office

Summitmas II 4th Floor, Jl. Jend. Sudirman Kav.61-62, Jakarta 12190, Indonesia

TEL: + 62 21 252 3202

SANYO DENKI GERMANY GmbH

Frankfurter Strasse 80-82, 65760 Eschborn, Germany

TEL: +49 6196 76113 0

SANYO DENKI KOREA CO., LTD.

15F, KDB Building, 372, Hangang-daero, Yongsan-gu, Seoul, 04323, Korea

TEL: +82 2 773 5623

Busan Branch

8F, CJ Korea Express Bldg., 119, Daegyo-ro, Jung-gu, Busan, 48943, Korea

TEL: +82 51 796 5151

SANYO DENKI (Shenzhen) CO., LTD.

2F 02-11, Shenzhen International Chamber of Commerce Tower, No.168 Fuhua 3 Road, Futian District, Shenzhen, 518048 China

TEL: +86 755 3337 3868

Tianjin Branch

Room AB 16th Floor TEDA Building, No. 256 Jie Fang Nan Road, Hexi District, Tianjin 300042 China

TEL: +86 22 2320 1186

Chengdu Branch

Room2105B, Block A, Times Plaza, 2 Zongfu Road, Jinjiang District, Chengdu, 610016 China

TEL: +86 28 8661 6901

SANYO DENKI (THAILAND) CO., LTD.

388 Exchange Tower, 25th Floor, Unit 2501-1, Sukhumvit Road, Klongtoey, Klongtoey, Bangkok 10110 Thailand

TEL: +66 2261 8670

SANYO DENKI INDIA PRIVATE LIMITED

#14 (Old No.6/3), Avenue Road, Nungambakkam, Chennai - 600034, Tamil Nadu, India

TEL: +91 44 420 384 72