

Electrical network protection

Sepam series 80

Installation and operation

User's manual
06/2008



Safety instructions

Safety symbols and messages

Read these instructions carefully and look at the equipment to become familiar with the device before trying to install, operate, service or maintain it. The following special messages may appear throughout this bulletin or on the equipment to warn of potential hazards or to call attention to information that clarifies or simplifies a procedure.



ANSI symbol.



IEC symbol.

Risk of electric shock

The addition of either symbol to a “Danger” or “Warning” safety label on a device indicates that an electrical hazard exists, which will result in death or personal injury if the instructions are not followed.

Safety alert



This is the safety alert symbol. It is used to alert you to potential personal injury hazards and prompt you to consult the manual. Obey all safety instructions that follow this symbol in the manual to avoid possible injury or death.

Safety messages

⚠ DANGER

DANGER indicates an imminently hazardous situation which, if not avoided, will result in death, serious injury or property damage.

⚠ WARNING

WARNING indicates a potentially hazardous situation which, if not avoided, could result in death, serious injury or property damage.

⚠ CAUTION

CAUTION indicates a potentially hazardous situation which, if not avoided, could result in minor or moderate injury or property damage.

Important notes

Restricted liability

Electrical equipment should be serviced and maintained only by qualified personnel. No responsibility is assumed by Schneider Electric for any consequences arising out of the use of this manual. This document is not intended as an instruction manual for untrained persons.

Device operation

The user is responsible for checking that the rated characteristics of the device are suitable for its application. The user is responsible for reading and following the device's operating and installation instructions before attempting to commission or maintain it. Failure to follow these instructions can affect device operation and constitute a hazard for people and property.

Protective grounding

The user is responsible for compliance with all the existing international and national electrical codes concerning protective grounding of any device.

General contents

Installation

1

Use

2

Commissioning

3

Maintenance

4



Safety instructions	4
Before starting	
Precautions	5
Equipment identification	6
List of Sepam series 80 references	8
Technical characteristics	10
Environmental characteristics	11
Base unit	12
Dimensions	12
Mounting	13
Connection	14
Connection of Sepam B83	16
Connection of Sepam C86	17
Connection of phase current inputs	18
Connection of residual current inputs	19
Connection of main voltage inputs	22
Connection of additional voltage inputs for Sepam B83	23
Connection of additional phase voltage input for Sepam B80	24
Functions available according to connected voltage inputs	25
1 A/5 A current transformers	26
LPCT type current sensors	29
CSH120 and CSH200 Core balance CTs	32
CSH30 interposing ring CT	34
ACE990 Core balance CT interface	36
Voltage transformers	38
MES120, MES120G, MES120H 14 input / 6 output modules	40
Presentation	40
Installation	41
Remote modules	43
MET148-2 Temperature sensor module	44
MSA141 Analog output module	46
DSM303 Remote advanced UMI module	48
MCS025 Synchro-check module	50
Communication accessory selection guide	54
Connection of communication accessories	55
ACE949-2 2-wire RS 485 network interface	56
ACE959 4-wire RS 485 network interface	57
ACE937 fiber optic interface	58
ACE969TP-2 and ACE969FO-2 Multi-protocol interfaces	59
Description	61
Connection	62
ACE909-2 RS 232/RS 485 converter	64
ACE919CA and ACE919CC RS 485/RS 485 converters	66
ECI850 IEC 61850 Sepam server	68

Safety instructions

Before starting

1

This page contains important safety instructions that must be followed precisely before attempting to install, repair, service or maintain electrical equipment. Carefully read and follow the safety instructions described below.

⚠ DANGER

HAZARD OF ELECTRIC SHOCK, ELECTRIC ARC, BURNS OR EXPLOSION

- Only qualified personnel should install this equipment. Such work should be performed only after reading this entire set of instructions.
- NEVER work alone.
- Turn off all power supplying this equipment before working on or inside it.
- Always use a properly rated voltage sensing device to confirm that all power is off.
- Before performing visual inspections, tests, or maintenance on this equipment, disconnect all sources of electric power. Assume that all circuits are live until they have been completely de-energized, tested and tagged. Pay particular attention to the design of the power system. Consider all sources of power, including the possibility of backfeeding.
- Beware of potential hazards, wear personal protective equipment, carefully inspect the work area for tools and objects that may have been left inside the equipment.
- The successful operation of this equipment depends upon proper handling, installation, and operation. Neglecting fundamental installation requirements can lead to personal injury as well as damage to electrical equipment or other property.
- Handling this product requires relevant expertise in the field of protection of electrical networks. Only competent people who have this expertise are allowed to configure and set up this product.
- Before performing Dielectric (Hi-Pot) or Megger testing on any equipment in which the relay is installed, disconnect all input and output wires to the relay. High voltage testing can damage electronic components contained in the Sepam unit.

Failure to follow these instructions will result in death or serious injury.

We recommend that you follow the instructions given in this document for quick, correct installation of your Sepam unit:

- Equipment identification
- Assembly
- Connection of inputs, current, voltage and sensors
- Connection of power supply
- Checking prior to commissioning

Transport, handing and storage

Sepam in its original packaging

Transport:

Sepam can be shipped to any destination by all usual means of transport without taking any additional precautions.

Handling:

Sepam can be handled without any particular care and can even withstand being dropped by a person standing at floor-level.

Storage:

Sepam can be stored in its original packaging, in an appropriate location for several years:

- Temperature between -25°C and +70°C (between -13°F and +158°F)
- Humidity ≤ 90%.

Periodic, yearly checking of the environment and the packaging condition is recommended.

Once Sepam has been unpacked, it should be energized as soon as possible.

Sepam installed in a cubicle

Transport:

Sepam can be transported by all usual means of transport in the customary conditions used for cubicles. Storage conditions should be taken into consideration for a long period of transport.

Handling:

Should the Sepam fall out of a cubicle, check its condition by visual inspection and energizing.

Storage:

Keep the cubicle protection packing for as long as possible. Sepam, like all electronic units, should not be stored in a damp environment for more than a month. Sepam should be energized as quickly as possible. If this is not possible, the cubicle reheating system should be activated.

Environment of the installed Sepam

Operation in a damp environment

The temperature/relative humidity factors must be compatible with the unit's environmental withstand characteristics.

If the use conditions are outside the normal zone, special arrangements should be made before commissioning, such as air conditioning of the premises.

Operation in a polluted atmosphere

A contaminated industrial atmosphere (such as the presence of chlorine, hydrofluoric acid, sulfur, solvents, etc.) can cause corrosion of the electronic components, in which case environmental control arrangements should be made (such as pressurized premises with filtered air, etc.) before commissioning.

The effect of corrosion on Sepam has been tested according to the IEC 60068-2-60 standard. Sepam is certified level C under the following test conditions:

- 2-gas test: 21 days, 25°C (77°F), 75% relative humidity, 0.5 ppm H₂S, 1 ppm SO₂
- 4-gas test: 21 days, 25°C (77°F), 75% relative humidity, 0.01 ppm H₂S, 0.2 ppm SO₂, 0.2 ppm NO₂, 0.01 ppm Cl₂

Identification of the base unit

Each Sepam is delivered in a separate package containing:

- 1 Sepam series 80 base unit, with its memory cartridge and two connectors (A) and (E) tightened
- 8 spring clips
- 1 terminal block identification label
- 2 keys (mimic-based UMI only)
- 1 Quick Start



The other optional accessories such as modules, current input connectors and cords are delivered in separate packages.

To identify a Sepam, inspect the 3 labels which are visible when the door on the front panel is opened:

- label with base unit hardware reference, stuck on the back of the door on the front panel:

Serial n° _____

Reference n° **59703** Serial N° **03050002**

Description Séries 80/HM avancée/24-250V
Series 80/advanced UMI/24-250V   



Commercial name **SEP080** Origin: France

Final testing: _____
date and _____
operator code _____

59703+01+1234567+C99
Test PASS: 12/14/2006
Operator: C99

- 2 labels stuck on the cartridge:

59707 Serial N° **0242004**

Memory cartridge series 80
Cartouche mémoire série 80  

MMS020 Origin: France

59707+01+1234567+C99

Cartridge hardware reference.

59730 substation S81
sous-station S81

59709 English / French series 80 33
Anglais / Français série 80 33

5973059709

Reference of software loaded in the cartridge:

- application
- working language.

Identification of accessories

The accessories such as optional modules, current or voltage connectors and connection cords come in separate packages, identified by labels.

- Example of MSA141 module identification label:

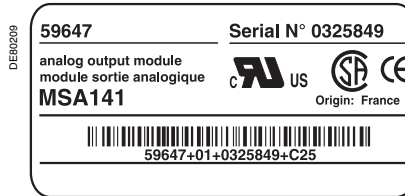

Reference	Designation
59608	DSM303, remote advanced UMI module
59629	CCA634 connector for 1 A/5 A + I0 CT current sensors
59630	CCA630 connector for 1A/5A CT current sensors
59632	CCT640 connector for VT voltage sensors
59634	CSH30 interposing ring CT for I0 input
59635	CSH120 residual current sensor, diameter 120 mm (4.75 in)
59636	CSH200 residual current sensor, diameter 200 mm (7.87 in)
59638	ECI850 IEC 61850 Sepam server with PRI surge arresters
59639	AMT852 lead sealing accessory
59641	MET148-2 8-temperature sensor module
59642	ACE949-2-wire RS 485 network interface
59643	ACE959 4-wire RS 485 network interface
59644	ACE937 fiber optic interface
59647	MSA141 1 analog output module
59648	ACE909-2 RS 485/RS 232 convertor
59649	ACE919 AC RS 485/RS 485 interface (AC power supply)
59650	ACE919 DC RS 485/RS 485 interface (DC power supply)
59660	CCA770 remote module cord, L = 0.6 m (2 ft)
59661	CCA772 remote module cord, L = 2 m (6.6 ft)
59662	CCA774 remote module cord, L = 4 m (13.1 ft)
59663	CCA612 RS 485 network interface communication cord, L = 3 m (9.8 ft)
59664	CCA783 PC connection cord
59665	CCA785 MCS025 module connection cord
59666	CCA613 remote LPCT test plug
59667	ACE917 LPCT injection adapter
59668	CCA620 20-pin screw type connector
59669	CCA622 20-pin ring lug connector
59670	AMT840 MCS025 mounting plate
59672	ACE990 core balance CT interface for I0 input
59676	Kit 2640 with 2 sets of spare connectors for MES
59679	SFT2841 CD-ROM with SFT2841 and SFT2826 software without CCA783 cord
59699	ATM820 blanking plate

Reference	Designation
59702	CCA671 connector for LPCT current sensors
59703	SEP080, base unit without UMI, 24-250 V DC power supply
59704	SEP383, base unit with advanced UMI, 24-250 V DC power supply
59705	SEP888 base unit with mimic-based UMI, 24-250 V DC power supply
59706	AMT880 Sepam series 80 mounting plate
59707	MMS020 memory cartridge
59709	Working language English/French
59710	Working language English/Spanish
59711	SFT080 Logipam option
59712	MCS025 synchro-check module
59715	MES120 14 input + 6 output module / 24-250 V DC
59716	MES120G 14 input + 6 output module / 220-250 V DC
59722	MES120H 14 input + 6 output module / 110-125 V DC
59723	ACE969TP-2 ⁽¹⁾ 2-wire RS 485 multi-protocol interface (Modbus, DNP3 or IEC 60870-5-103)
59724	ACE969FO-2 ⁽¹⁾ fiber-optic multi-protocol interface (Modbus, DNP3 or IEC 60870-5-103)
59726	CD SFT850 CD-ROM with IEC 61850 configuration software
59727	CD SFT2885 CD-ROM with Logipam software
59729	Substation application type S80
59730	Substation application type S81
59731	Substation application type S82
59732	Substation application type S84
59733	Transformer application type T81
59734	Transformer application type T82
59735	Transformer application type T87
59736	Motor application type M81
59737	Motor application type M87
59738	Motor application type M88
59739	Generator application type G82
59741	Generator application type G87
59742	Generator application type G88
59743	Busbar application type B80
59744	Busbar application type B83
59745	Capacitor application type C86
TSXCUSB232	USB/RS 232 converter
TCSEAK0100	Ethernet configuration kit for ECI850

(1) Référence 59720 ACE969TP cancelled and replaced by 59723, référence 59721 ACE969FO cancelled and replaced by 59724.

Weight

	Base unit with advanced UMI	Base unit with mimic-based UMI
Minimum weight (base unit without MES120)	2.4 kg (5.29 lb)	3.0 kg (6.61 lb)
Maximum weight (base unit with 3 MES120)	4.0 kg (8.82 lb)	4.6 kg (10.1 lb)

Sensor inputs**Phase current inputs 1 A or 5 A CT**

Input impedance	< 0.02 Ω
Consumption	< 0.02 VA (1 A CT) < 0.5 VA (5 A CT)
Continuous thermal withstand	4 In
1 second overload	100 In (500 A)

Voltage inputs

	Phase	Residual
Input impedance	> 100 kΩ	> 100 kΩ
Consumption	< 0.015 VA (100 V VT)	< 0.015 VA (100 V VT)
Continuous thermal withstand	240 V	240 V
1-second overload	480 V	480 V
Isolation of inputs from other isolated groups	Enhanced	Enhanced

Relay outputs**Control relay outputs O1 to O4 and Ox01 ⁽¹⁾**

Voltage	DC	24/48 V DC	127 V DC	220 V DC	250 V DC	-
	AC (47.5 to 63 Hz)	-	-	-	-	100 to 240 V AC
Continuous current		8 A	8 A	8 A	8 A	8 A
Breaking capacity	Resistive load	8 A / 4 A	0.7 A	0.3 A	0.2 A	-
	L/R Load < 20	6 A / 2 A	0.5 A	0.2 A	-	-
	L/R Load < 40 ms	4 A / 1 A	0.2 A	0.1 A	-	-
	Resistive load	-	-	-	-	8 A
	p.f. load > 0.3	-	-	-	-	5 A
Making capacity		< 15 A for 200 ms				
Isolation of outputs from other isolated groups		Enhanced				

Annunciation relay output O5 and Ox02 to Ox06

Voltage	DC	24/48 V DC	127 V DC	220 V DC	250 V DC	-
	AC (47.5 to 63 Hz)	-	-	-	-	100 to 240 V AC
Continuous current		2 A	2 A	2 A	2 A	2 A
Breaking capacity	Resistive load	2 A / 1 A	0.6 A	0.3 A	0.2 A	-
	L/R Load < 20 ms	2 A / 1 A	0.5 A	0.15 A	-	-
	p.f. load > 0.3	-	-	-	-	1 A
Isolation of outputs from other isolated groups		Enhanced				

Power supply

Voltage	24 to 250 V DC	-20 % / +10 %
Maximum consumption	< 16 W	
Inrush current	< 10 A 10 ms	
Acceptable ripple content	12 %	
Acceptable momentary outages	100 ms	

Battery

Format	1/2 AA lithium 3.6 V
Service life	10 years Sepam energized 8 years Sepam not energized

(1) Relay outputs complying with clause 6.7 of standard C37.90 (30 A, 200 ms, 2000 operations).

Electromagnetic compatibility	Standard	Level / Class	Value
Emission tests			
Disturbing field emission	IEC 60255-25 EN 55022	A	
Conducted disturbance emission	IEC 60255-25 EN 55022	A	
Immunity tests – Radiated disturbances			
Immunity to radiated fields	IEC 60255-22-3 IEC 61000-4-3 ANSI C37.90.2 (1995)	III	10 V/m; 80 MHz -1 GHz 10 V/m; 80 MHz - 2 GHz 35 V/m; 25 MHz - 1 GHz
Electrostatic discharge	IEC 60255-22-2 ANSI C37.90.3		8 kV air; 6 kV contact 8 kV air; 4 kV contact
Immunity to magnetic fields at network frequency ⁽¹⁾	IEC 61000-4-8	4	30 A/m (continuous) - 300 A/m (1 - 3 s)
Immunity tests – Conducted disturbances			
Immunity to conducted RF disturbances	IEC 60255-22-6	III	10 V
Fast transient bursts	IEC 60255-22-4 IEC 61000-4-4 ANSI C37.90.1	A and B IV	4 kV; 2.5 kHz / 2 kV; 5 kHz 4 kV; 2.5 kHz 4 kV; 2.5 kHz
1 MHz damped oscillating wave	IEC 60255-22-1 ANSI C37.90.1		2.5 kV CM; 1 kV DM 2.5 kV; 2.5 kHz
100 kHz damped oscillating wave	IEC 61000-4-12		2.5 kV CM ; 1 kV DM
Surges	IEC 61000-4-5	III	2 kV CM; 1 kV DM
Voltage interruptions	IEC 60255-11		100 % during 100 ms
Mechanical robustness			
In operation			
Vibrations	IEC 60255-21-1 IEC 60068-2-6	2 Fc	1 Gn; 10 Hz - 150 Hz 2 Hz - 13.2 Hz ; a = ±1 mm
Shocks	IEC 60255-21-2	2	10 Gn / 11 ms
Earthquakes	IEC 60255-21-3	2	2 Gn (horizontal axes) 1 Gn (vertical axes)
De-energized			
Vibrations	IEC 60255-21-1	2	2 Gn; 10 Hz - 150 Hz
Shocks	IEC 60255-21-2	2	27 Gn / 11 ms
Jolts	IEC 60255-21-2	2	20 Gn / 16 ms
Climatic withstand			
In operation			
Exposure to cold	IEC 60068-2-1	Ad	-25°C (-13°F)
Exposure to dry heat	IEC 60068-2-2	Bd	+70°C (+158°F)
Continuous exposure to damp heat	IEC 60068-2-78	Cab	10 days; 93 % RH; 40°C (104°F)
Salt mist	IEC 60068-2-52	Kb/2	6 days
Influence of corrosion/2-gas test	IEC 60068-2-60		21 days; 75 % RH; 25°C (77°F); 0.5 ppm H ₂ S; 1 ppm SO ₂
Influence of corrosion/4-gas test	IEC 60068-2-60		21 days; 75 % RH; 25°C (77°F); 0.01 ppm H ₂ S; 0.2 ppm SO ₂ ; 0.2 ppm NO ₂ ; 0.01 ppm Cl ₂
In storage ⁽²⁾			
Temperature variation with specified variation rate	IEC 60068-2-14	Nb	-25°C to +70°C (-13°F to +158°F); 5°C/min
Exposure to cold	IEC 60068-2-1	Ab	-25°C (-13°F)
Exposure to dry heat	IEC 60068-2-2	Bb	+70°C (+158°F)
Continuous exposure to damp heat	IEC 60068-2-78 IEC 60068-2-30	Cab Db	56 days; 93 % RH; 40°C (104°F) 6 days; 95 % RH; 55°C (131°F)
Safety			
Enclosure safety tests			
Front panel tightness	IEC 60529 NEMA	IP52 Type 12	Other panels IP20
Fire withstand	IEC 60695-2-11		650°C (1200°F) with glow wire
Electrical safety tests			
1.2/50 μs impulse wave	IEC 60255-5		5 kV ⁽³⁾
Power frequency dielectric withstand	IEC 60255-5 ANSI C37.90		2 kV 1 min ⁽⁴⁾ 1 kV 1 min (annunciation output) 1.5 kV 1 min (control output)
Certification			
CE	EN 50263 harmonized standard	European directives: ■ 89/336/EEC Electromagnetic Compatibility (EMC) Directive □ 92/31/EEC Amendment □ 93/68/EEC Amendment ■ 73/23/EEC Low Voltage Directive □ 93/68/EEC Amendment	
UL 	UL508 - CSA C22.2 no. 14-95		File E212533
CSA	CSA C22.2 no. 14-95 / no. 94-M91 / no. 0.17-00		File 210625

(1) When protection function 50N/51N or 67N is used and I0 is calculated on the sum of phase currents, Is0 must be higher than 0.1In0.
 (2) Sepam must be stored in its original packaging.
 (3) Except for communication: 3 kV in common mode and 1 kV in differential mode.
 (4) Except for communication: 1 kVrms.

1

Dimensions

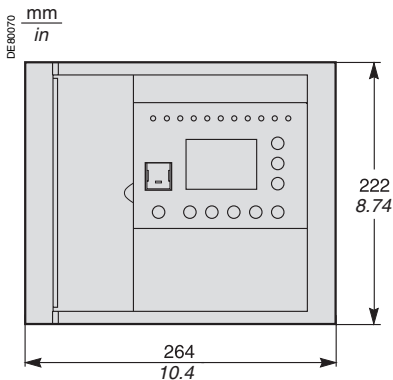

Front view of Sepam.

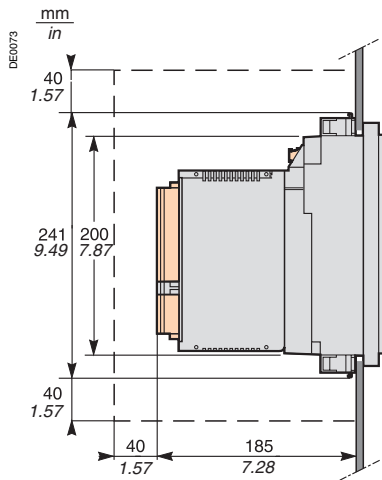

Side view of Sepam with MES120, flush-mounted in front panel with spring clips.
Front panel: 1.5 mm (0.05 in) to 6 mm (0.23 in) thick.

— — — Clearance for Sepam assembly and wiring.

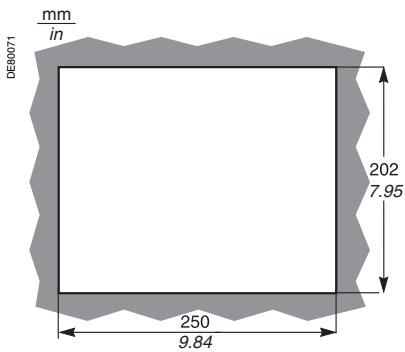

Cut out.

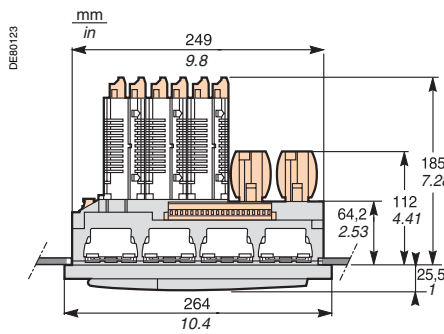

Top view of Sepam with MES120, flush-mounted in front panel with spring clips.
Front panel: 1.5 mm (0.05 in) to 6 mm (0.23 in) thick.

⚠ CAUTION

HAZARD OF CUTS

Trim the edges of the cut-out plates to remove any jagged edges.

Failure to follow this instruction can cause serious injury.

Assembly with AMT880 mounting plate

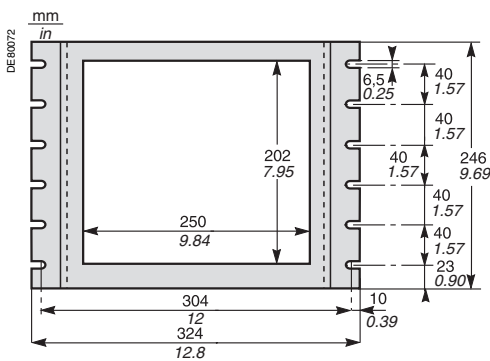

AMT880 mounting plate.

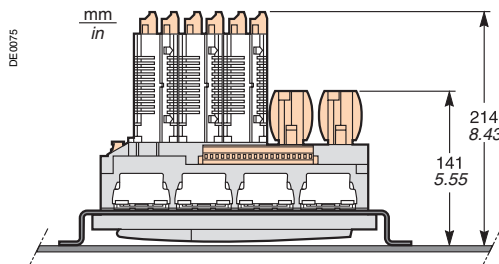

Top view of Sepam with MES120, flush-mounted in front panel with spring clips.
Mounting plate: 3 mm (0.11 in) thick.

Spring clip mounting direction

The direction in which the spring clips are mounted depends on the thickness of the mounting frame. The top clips are mounted in the opposite direction to the bottom clips.

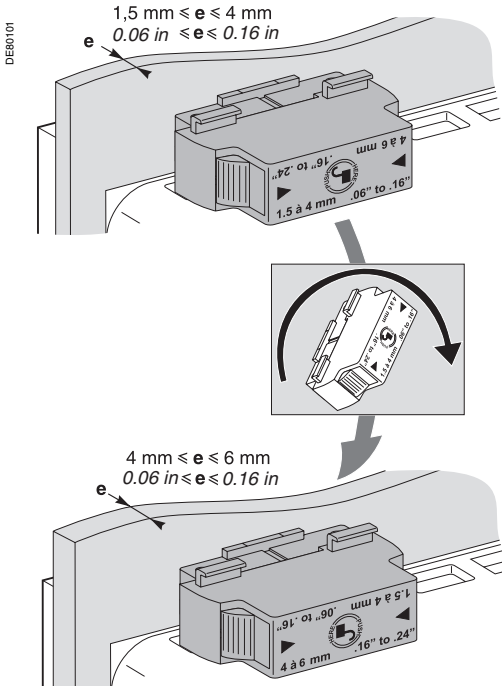

Base unit flush-mounting

Sepam series 80 is mounted on the mounting frame by 8 spring clips. The mounting surface must be flat and stiff to guarantee tightness.

⚠ DANGER

HAZARD OF ELECTRIC SHOCK, ELECTRIC ARC OR BURNS

- Only qualified personnel should install this equipment. Such work should be performed only after reading this entire set of instructions.
- NEVER work alone.
- Turn off all power supplying this equipment before working on or inside it. Consider all sources of power, including the possibility of backfeeding.
- Always use a properly rated voltage sensing device to confirm that all power is off.

Failure to follow these instructions will result in death or serious injury.

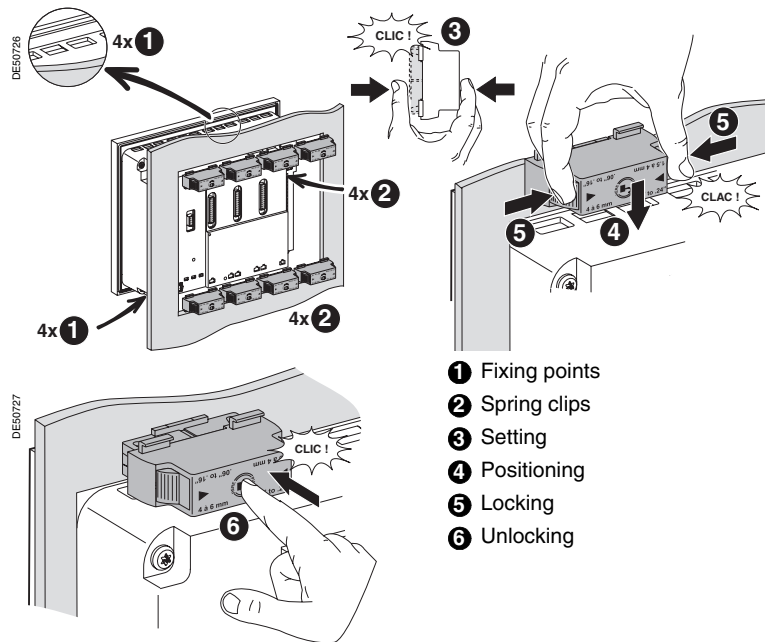

- 1 Fixing points
- 2 Spring clips
- 3 Setting
- 4 Positioning
- 5 Locking
- 6 Unlocking

Installing the terminal block identification label

A sticker showing the rear panel of Sepam and terminal assignments is supplied with each base unit to facilitate the installation and connection of Sepam and the MES120 input/output modules.

You may stick it in the location of your choice, e.g. on the side of an MES120 module or on the right-hand side panel of Sepam.

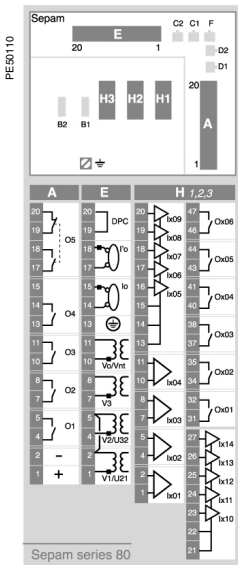

Terminal block identification label

1

- 1 Base unit.
 - 2 8 fixing points for 4 spring clips.
 - 3 Red LED: Sepam unavailable.
 - 4 Green LED: Sepam on.
 - 5 Gasket.
- (A) 20-pin connector for:
 - 24 V DC to 250 V DC auxiliary supply
 - 5 relay outputs.
 - (B1) Connector for 3 phase current I1, I2, I3 inputs.
 - (B2) ■ Sepam T87, M87, M88, G87, G88: connector for 3 phase current I'1, I'2, I'3 inputs
 - Sepam B83: connector for
 - 3 phase voltage V'1, V'2, V'3 inputs
 - 1 residual voltage V'0 input.
 - Sepam C86: connector for capacitor unbalance current inputs.
 - (C1) Communication port 1.
 - (C2) Communication port 2.
 - (D1) Remote module connection port 1.
 - (D2) Remote module connection port 2.
 - (E) 20-pin connector for:
 - 3 phase voltage V1, V2, V3 inputs
 - 1 residual voltage V0 input.
 - 2 residual current I0, I'0 inputs.
 - (F) Spare port.

Rear panel description

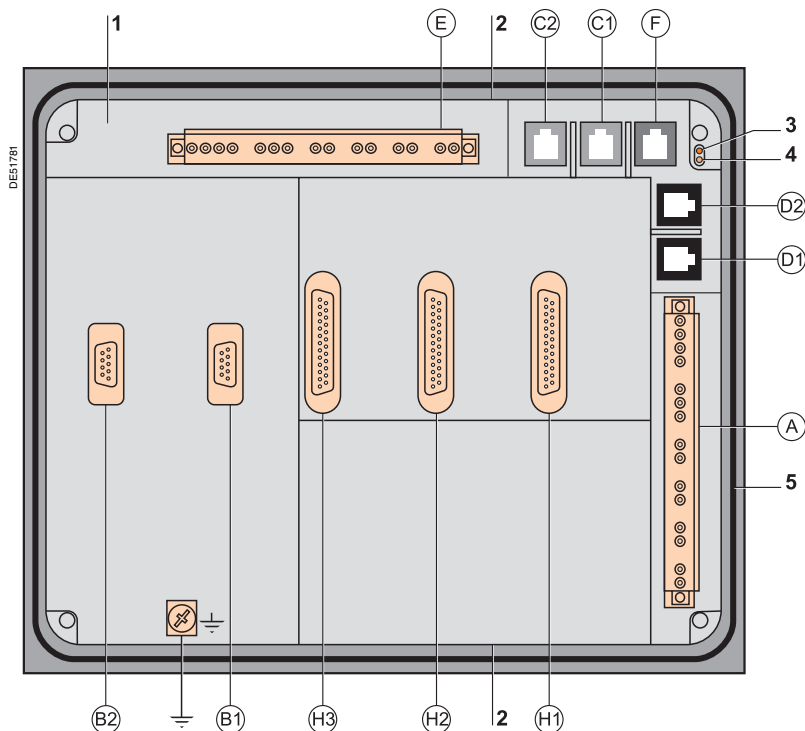

- (H1) Connector for 1st MES120 input/output module.
- (H2) Connector for 2nd MES120 input/output module.
- (H3) Connector for 3rd MES120 input/output module.

⊥ Functional earth.

Connection characteristics

Connector	Type	Reference	Wiring
(A) · (E)	Screw type	CCA620	<ul style="list-style-type: none"> ■ wiring with no fittings: <ul style="list-style-type: none"> □ 1 wire with max. cross-section 0.2 to 2.5 mm² (≥ AWG 24-12) or 2 wires with max. cross-section 0.2 to 1 mm² (≥ AWG 24-16) □ stripped length: 8 to 10 mm (0.31 to 0.39 in) ■ wiring with fittings: <ul style="list-style-type: none"> □ recommended wiring with Telemecanique fittings: <ul style="list-style-type: none"> - DZ5CE015D for 1 x 1.5 mm² wire (AWG 16) - DZ5CE025D for 1 x 2.5 mm² wire (AWG 12) - AZ5DE010D for 2 x 1 mm² wires (AWG 18) □ tube length: 8.2 mm (0.32 in) □ stripped length: 8 mm (0.31 in)
	6.35 mm (0.25 in) ring lugs	CCA622	<ul style="list-style-type: none"> ■ 6.35 mm ring or spade lugs (0.25 in) (1/4") ■ maximum wire cross-section of 0.2 to 2.5 mm² (≥ AWG 24-12) ■ stripped length: 6 mm (0.23 in) ■ use an appropriate tool to crimp the lugs on the wires ■ maximum of 2 ring or spade lugs per terminal ■ tightening torque: 0.7 to 1 Nm (8.85 lb-in)
(B1) · (B2)	4 mm (0.15 in) ring lugs	CCA630 or CCA634, for connection of 1 A or 5 A CTs	<ul style="list-style-type: none"> ■ wire with cross-section 1.5 to 6 mm² (AWG 16-10) ■ stripped length: 6 mm (0.236 in) ■ use an appropriate tool to crimp the lugs on the wires ■ tightening torque: 1.2 N.m (11 lb-in)
	RJ45 plug	CCA671, for connection of 3 LPCT sensors	Integrated with LPCT sensor
(C1) · (C2)	Green RJ45 plug		CCA612
(D1) · (D2)	Black RJ45 plug		CCA770: L = 0.6 m (2 ft) CCA772: L = 2 m (6.6 ft) CCA774: L = 4 m (13.1 ft) CCA785 for MCS025 module: L = 2 m (6.6 ft)
	Ring lug		Earthing braid, to be connected to cubicle grounding: <ul style="list-style-type: none"> ■ flat copper braid with cross-section ≥ 9 mm² (> AWG 8) ■ maximum length: 300 mm (11.8 in)
	Functional earth		

DEE1845

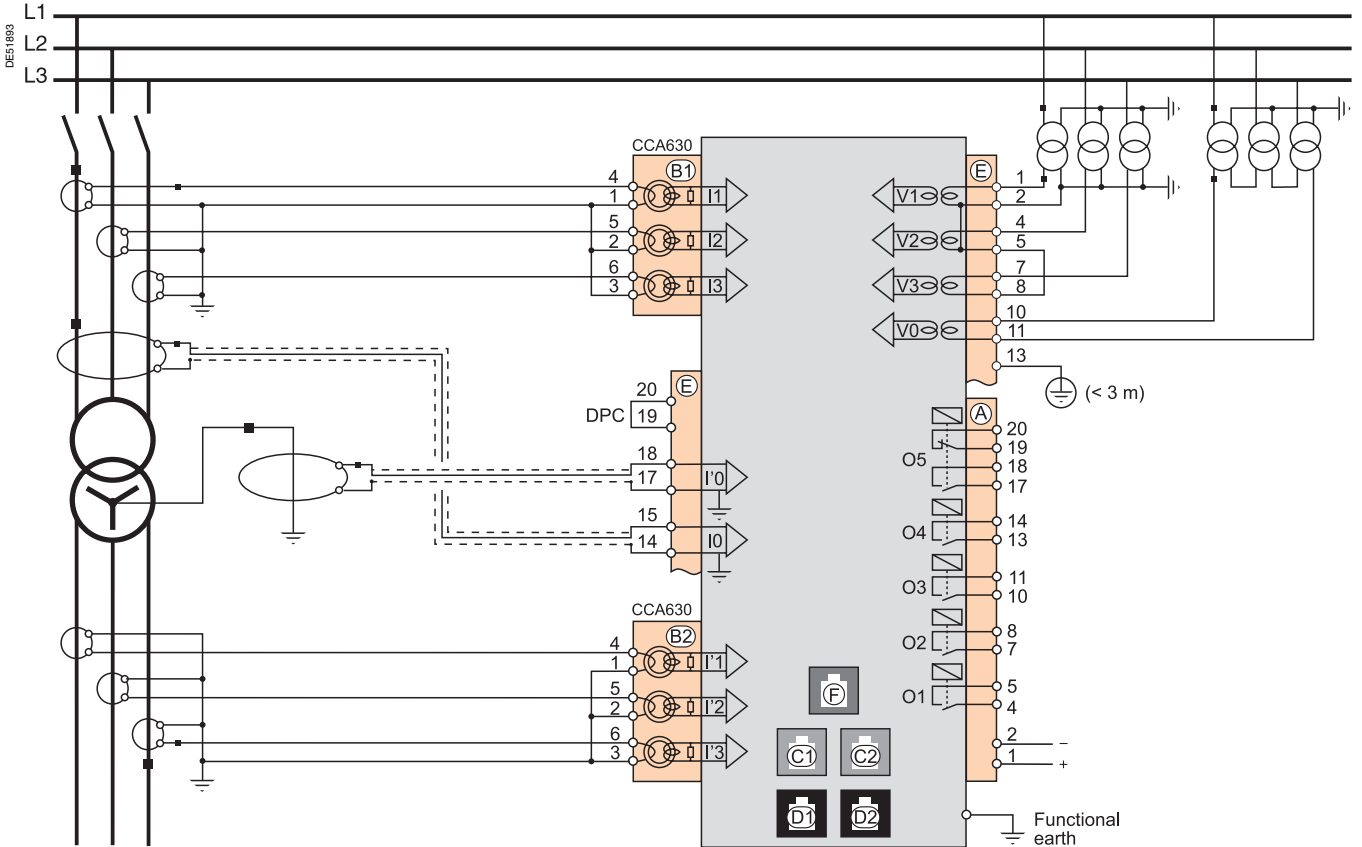

Note: See connection characteristics page 14

⚠ CAUTION

LOSS OF PROTECTION OR RISK OF NUISANCE TRIPPING

If the Sepam is no longer supplied with power or is in fail-safe position, the protection functions are no longer active and all the Sepam output relays are dropped out. Check that this operating mode and the watchdog relay wiring are compatible with your installation.

Failure to follow this instruction can result in equipment damage and unwanted shutdown of the electrical installation.

⚠ DANGER

HAZARD OF ELECTRIC SHOCK, ELECTRIC ARC OR BURNS

■ Only qualified personnel should install this equipment. Such work should be performed only after reading this entire set of instructions.

■ NEVER work alone.

■ Turn off all power supplying this equipment before working on or inside it. Consider all sources of power, including the possibility of backfeeding.

■ Always use a properly rated voltage sensing device to confirm that all power is off.

■ Start by connecting the device to the protective earth and to the functional earth.

■ Screw tight all terminals, even those not in use.

Failure to follow these instructions will result in death or serious injury.

Base unit Connection of Sepam B83

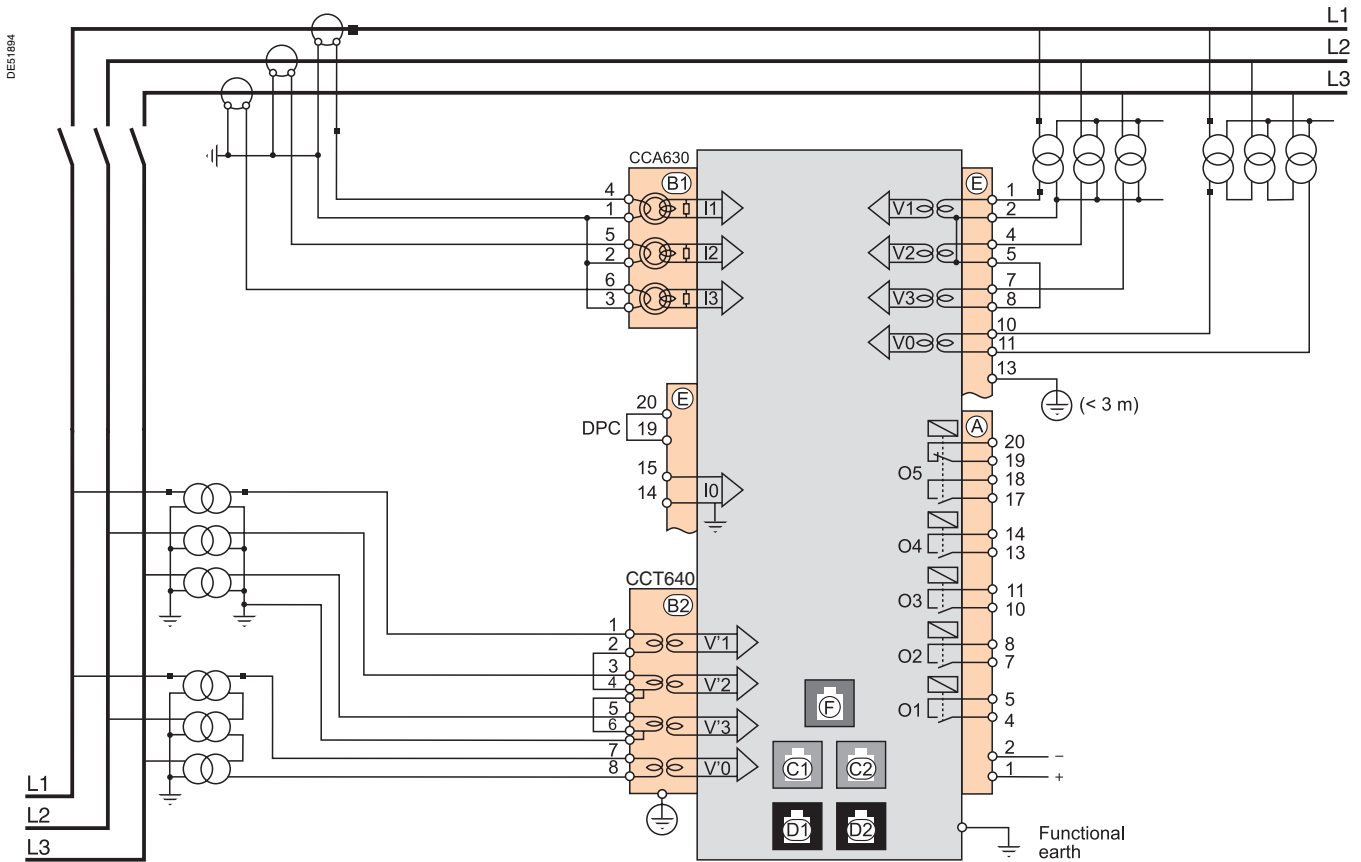

Connector	Type	Reference	Wiring
(B1)	4 mm (0.15 in) ring lugs	CCA630 or CCA634, for connection of 1 A or 5 A CTs	<ul style="list-style-type: none"> wire with cross-section 1.5 to 6 mm² (AWG 16-10) stripped length: 6 mm (0.236 in) use an appropriate tool to crimp the lugs on the wires tightening torque: 1.2 N.m (11 lb-in)
(B2)	Screw type	CCT640	<ul style="list-style-type: none"> VT wiring: identical to the CCA620 wiring Earthing connection: by 4 mm (0.16 in) ring lug tightening torque: 1.2 N.m (11 lb-in)
Functional earth	Ring lug		Earthing braid, to be connected to cubicle grounding: <ul style="list-style-type: none"> flat copper braid with cross-section $\geq 9\text{ mm}^2$ ($>$ AWG 8) maximum length: 300 mm (11.8 in)

Connection characteristics of connectors (A), (E), (C1), (C2), (D1), (D2) : see page 14

⚠ CAUTION

LOSS OF PROTECTION OR RISK OF NUISANCE TRIPPING

If the Sepam is no longer supplied with power or is in fail-safe position, the protection functions are no longer active and all the Sepam output relays are dropped out. Check that this operating mode and the watchdog relay wiring are compatible with your installation.

Failure to follow this instruction can result in equipment damage and unwanted shutdown of the electrical installation.

⚠ DANGER

HAZARD OF ELECTRIC SHOCK, ELECTRIC ARC OR BURNS

- Only qualified personnel should install this equipment. Such work should be performed only after reading this entire set of instructions.
- NEVER work alone.
- Turn off all power supplying this equipment before working on or inside it. Consider all sources of power, including the possibility of backfeeding.
- Always use a properly rated voltage sensing device to confirm that all power is off.
- Start by connecting the device to the protective earth and to the functional earth.
- Screw tight all terminals, even those not in use.

Failure to follow these instructions will result in death or serious injury.

Base unit Connection of Sepam C86

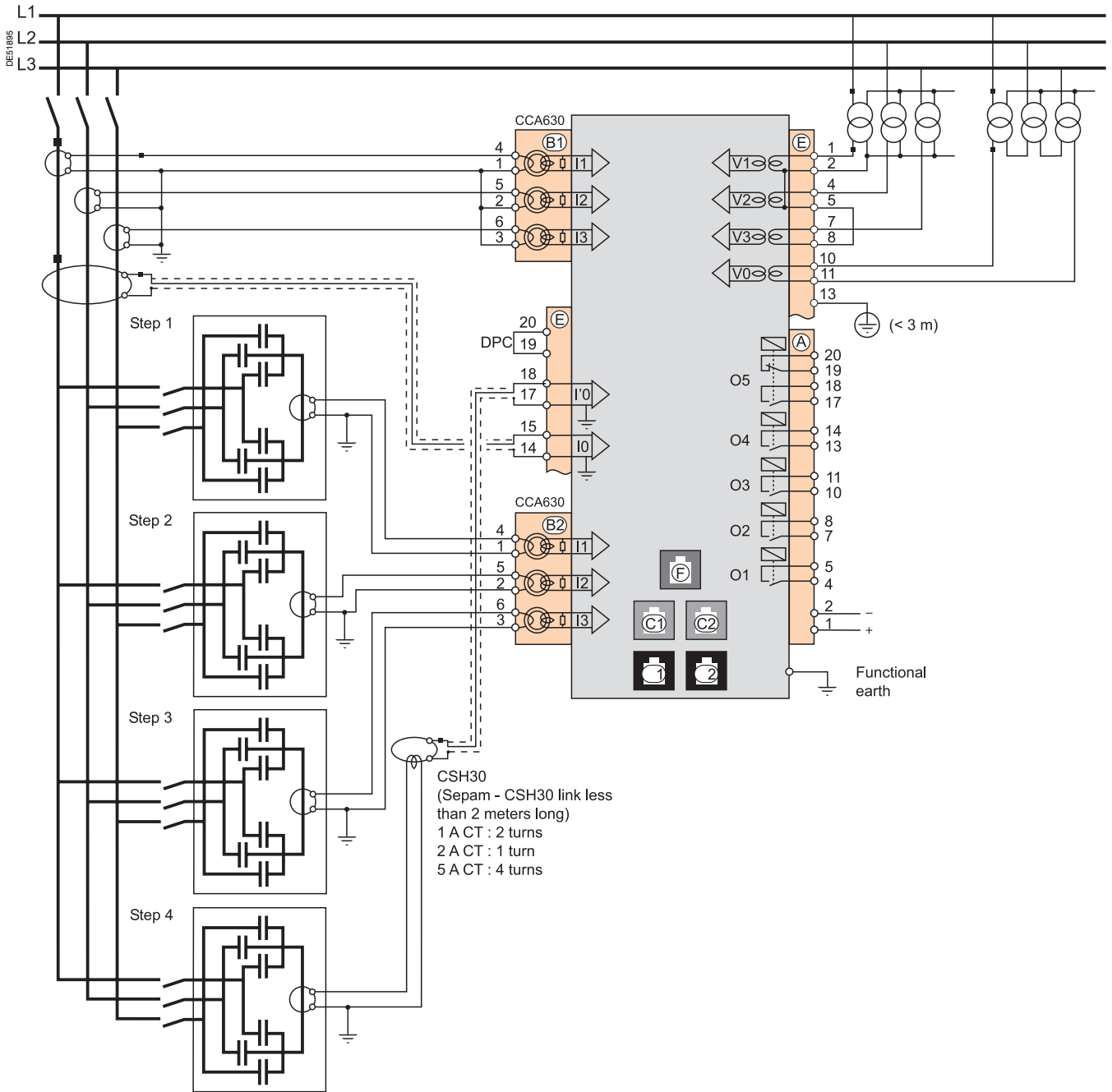

Connector	Type	Reference	Wiring
(B1)	4 mm (0.15 in) ring lugs	CCA630 or CCA634, for connection of 1 A or 5 A CTs	<ul style="list-style-type: none"> wire with cross-section 1.5 to 6 mm² (AWG 16-10) stripped length: 6 mm (0.236 in) use an appropriate tool to crimp the lugs on the wires tightening torque: 1.2 N.m (11 lb-in)
	RJ45 plug	CCA671, for connection of 3 LPCT sensors	Integrated with LPCT sensor
(B2)	4 mm (0.15 in) ring lugs	CCA630 or CCA634, for connection of 1 A, 2A or 5 A CTs	<ul style="list-style-type: none"> wire with cross-section 1.5 to 6 mm² (AWG 16-10) stripped length: 6 mm (0.236 in) use an appropriate tool to crimp the lugs on the wires tightening torque: 1.2 N.m (11 lb-in)
Functional earth	Ring lugs		Earthing braid, to be connected to cubicle grounding: <ul style="list-style-type: none"> flat copper braid with cross-section ≥ 9 mm² (>AWG 8) maximum length: 300 mm (11.8 in)

DE51845

Connection characteristics of connectors (A), (E), (C1), (C2), (D1), (D2) : see page 14

1

Variant 1: phase current measurement by 3 x 1 A or 5 A CTs (standard connection)

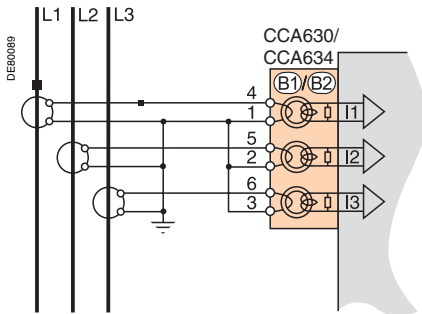

Description

Connection of 3 x 1 A or 5 A sensors to the CCA630 or CCA634 connector.

The measurement of the 3 phase currents allows the calculation of residual current.

Parameters

Sensor type	5 A CT or 1 A CT
Number of CTs	I1, I2, I3
Rated current (In)	1 A to 6250 A

Variant 2: phase current measurement by 2 x 1 A or 5 A CTs

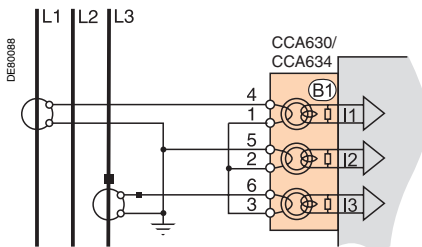

Description

Connection of 2 x 1 A or 5 A sensors to the CCA630 or CCA634 connector.

Measurement of phase 1 and 3 currents is sufficient for all protection functions based on phase current.

The phase current I2 is only assessed for metering functions, assuming that $I_0 = 0$.

This arrangement does not allow the calculation of residual current, nor use of ANSI 87T and 87M differential protection functions on the Sepam T87, M87, M88, G87 and G88.

Paramètres

Sensor type	5 A CT or 1 A CT
Number of CTs	I1, I3
Rated current (In)	1 A to 6250 A

Variant 3: phase current measurement by 3 LPCT type sensors

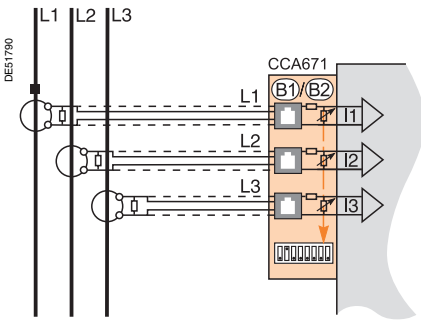

Description

Connection of 3 Low Power Current Transducer (LPCT) type sensors to the CCA671 connector. It is necessary to connect 3 sensors; if only one or two sensors are connected, Sepam goes into fail-safe position.

Measurement of the 3 phase currents allows the calculation of residual current.

It is not possible to use LPCT sensors for the following measurements:

- phase-current measurements for Sepam T87, M88 and G88 with ANSI 87T transformer differential protection (connectors B1 and B2)
- phase-current measurements for Sepam B83 (connector B1)
- unbalance-current measurements for Sepam C86 (connector B2).

Parameters

Sensor type	LPCT
Number of CTs	I1, I2, I3
Rated current (In)	25, 50, 100, 125, 133, 200, 250, 320, 400, 500, 630, 666, 1000, 1600, 2000 or 3150 A

Note: Parameter In must be set twice:

- Software parameter setting using the advanced UMI or the SFT2841 software tool
- Hardware parameter setting using microswitches on the CCA671 connector

1

Variant 1: residual current calculation by sum of 3 phase currents

Description

Residual current is calculated by the vector sum of the 3 phase currents I1, I2 and I3, measured by 3 x 1 A or 5 A CTs or by 3 LPCT type sensors. See current input connection diagrams.

Parameters

Residual current	Rated residual current	Measuring range
Sum of 3 Is	$I_{n0} = I_n$, CT primary current	0.01 to 40 I_{n0} (minimum 0.1 A)

Variant 2: residual current measurement by CSH120 or CSH200 core balance CT (standard connection)

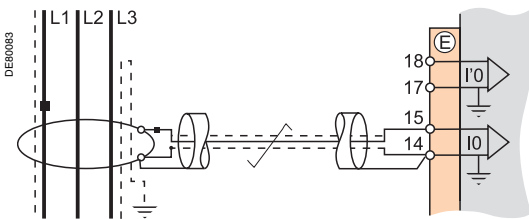

Description

Arrangement recommended for the protection of isolated or compensated neutral systems, in which very low fault currents need to be detected.

Parameters

Residual current	Rated residual current	Measuring range
2 A rating CSH	$I_{n0} = 2$ A	0.1 to 40 A
20 A rating CSH	$I_{n0} = 20$ A	0.2 to 400 A

Variant 3: residual current measurement by 1 A or 5 A CTs and CCA634

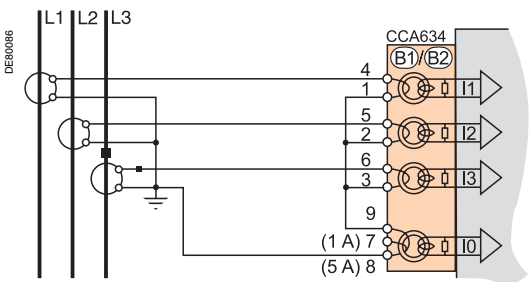

Description

Residual current measurement by 1 A or 5 A CTs

- Terminal 7: 1 A CT
- Terminal 8: 5 A CT

Parameters

Residual current	Rated residual current	Measuring range
1 A CT	$I_{n0} = I_n$, CT primary current	0.01 to 20 I_{n0} (minimum 0.1 A)
5 A CT	$I_{n0} = I_n$, CT primary current	0.01 to 20 I_{n0} (minimum 0.1 A)

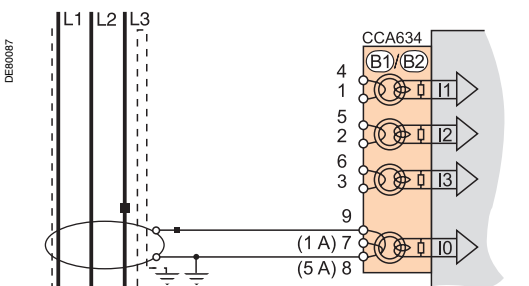

Variant 4: residual current measurement by 1 A or 5 A CTs and CSH30 interposing ring CT

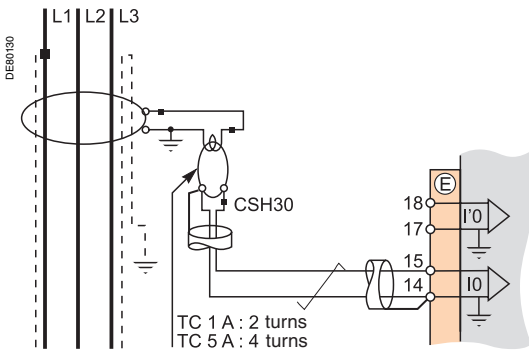

Description

The CSH30 interposing ring CT is used to connect 1 A or 5 A CTs to Sepam to measure residual current:

- CSH30 interposing ring CT connected to 1 A CT: make 2 turns through CSH primary
- CSH30 interposing ring CT connected to 5 A CT: make 4 turns through CSH primary.

Paramètres

Residual current	Rated residual current	Measuring range
1 A CT	$I_{n0} = I_n$, CT primary current	0.01 to 20 I_{n0} (minimum 0.1 A)
5 A CT	$I_{n0} = I_n$, CT primary current	0.01 to 20 I_{n0} (minimum 0.1 A)

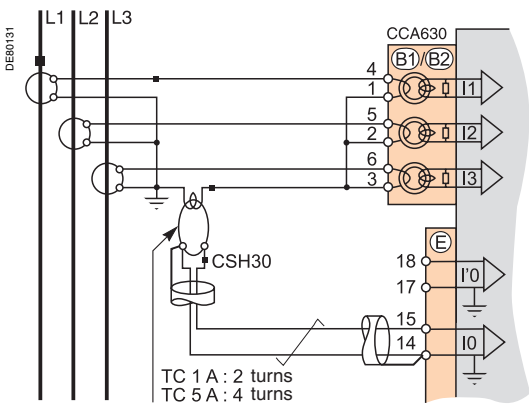

Variant 5: residual current measurement by core balance CT with ratio of 1/n (n between 50 and 1500)

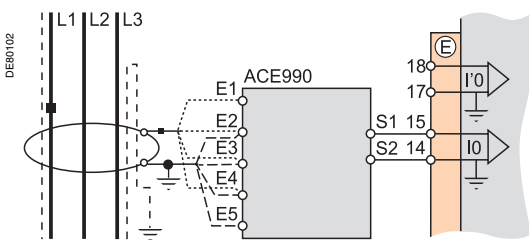

Description

The ACE990 is used as an interface between a MV core balance CT with a ratio of 1/n ($50 \leq n \leq 1500$) and the Sepam residual current input.

This arrangement allows the continued use of existing core balance CTs on the installation.

Parameters

Residual current	Rated residual current	Measuring range
ACE990 - range 1	$I_{n0} = I_k \cdot n^{(1)}$ ($0.00578 \leq k \leq 0.04$)	0.01 to 20 I_{n0} (minimum 0.1 A)
ACE990 - range 2	$I_{n0} = I_k \cdot n^{(1)}$ ($0.0578 \leq k \leq 0.26316$)	0.01 to 20 I_{n0} (minimum 0.1 A)

(1) n = number of core balance CT turns

k = factor to be determined according to ACE990 wiring and setting range used by Sepam

1

Variant 1: measurement of 3 phase-to-neutral voltages (3 V, standard connection)

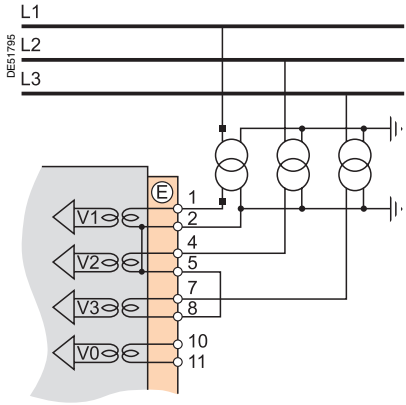

Measurement of the 3 phase-to-neutral voltages allows the calculation of residual voltage, $V_{0\Sigma}$.

Phase voltage input connection variants

Variant 2: measurement of 2 phase-to-phase voltages (2 U)

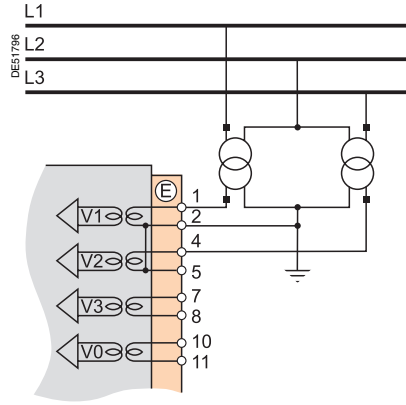

This variant does not allow the calculation of residual voltage.

Variant 3: measurement of 1 phase-to-phase voltage (1 U)

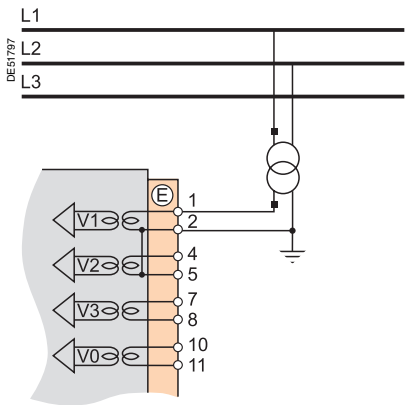

This variant does not allow the calculation of residual voltage.

Variant 4: measurement of 1 phase-to-neutral voltage (1 V)

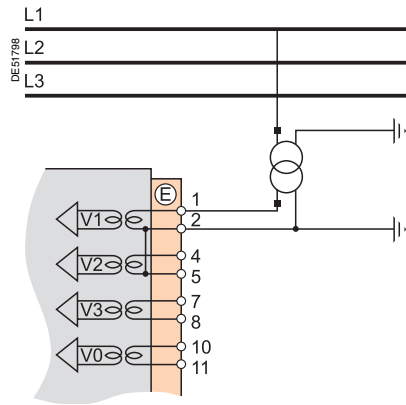

This variant does not allow the calculation of residual voltage.

Variant 5: measurement of residual voltage V0

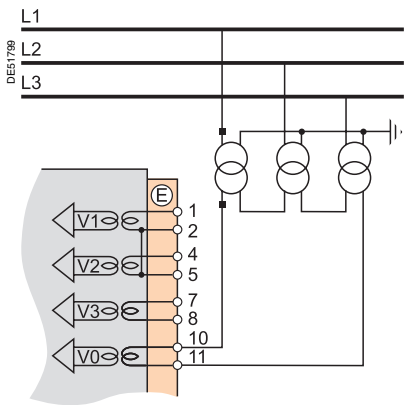

Residual voltage input connection variants

Variant 6: measurement of residual voltage V_{nt} in generator neutral point

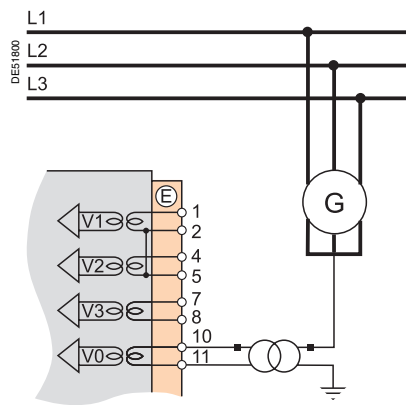

Variant 1: measurement of 3 phase-to-neutral voltages (3 V', standard connection)

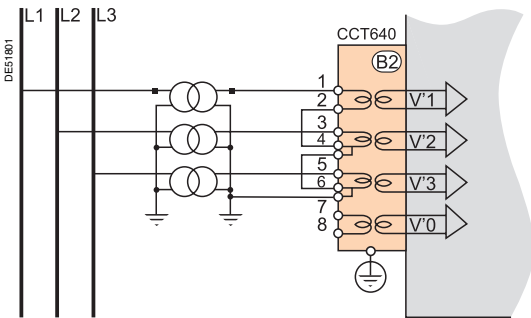

Measurement of the 3 phase-to-neutral voltages allows the calculation of residual voltage, $V'0\Sigma$.

Additional phase voltage input connection variants

Variant 2: measurement of 2 phase-to-phase voltages (2 U')

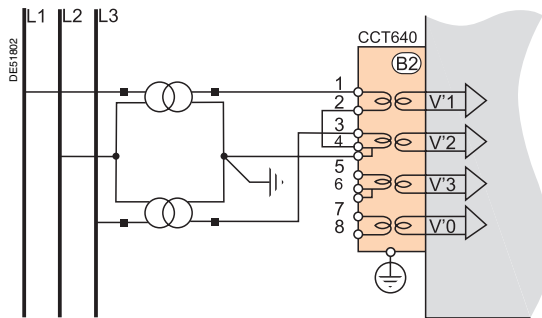

This variant does not allow the calculation of residual voltage.

Variant 3: measurement of 1 phase-to-phase voltage (1 U')

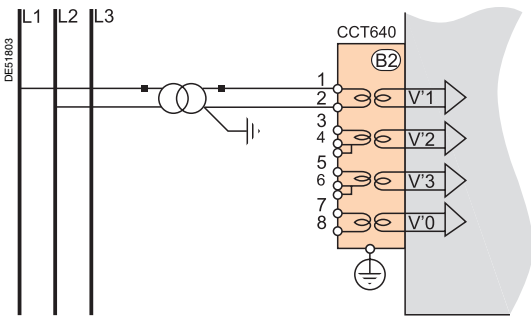

This variant does not allow the calculation of residual voltage.

Variant 4: measurement of 1 phase-to-neutral voltage (1 V')

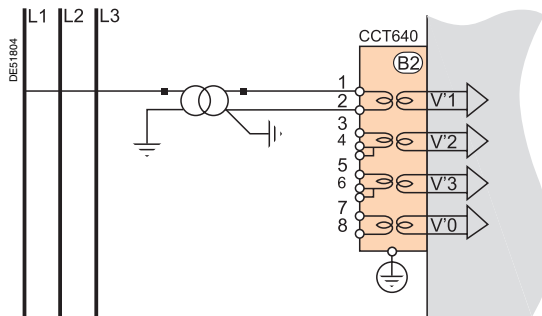

This variant does not allow the calculation of residual voltage.

Additional residual voltage input connection

Variant 5: measurement of residual voltage V'0

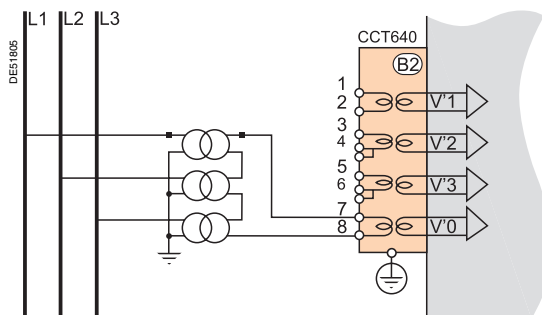

Base unit

Connection of additional phase voltage input for Sepam B80

1

Connection to measure one additional voltage

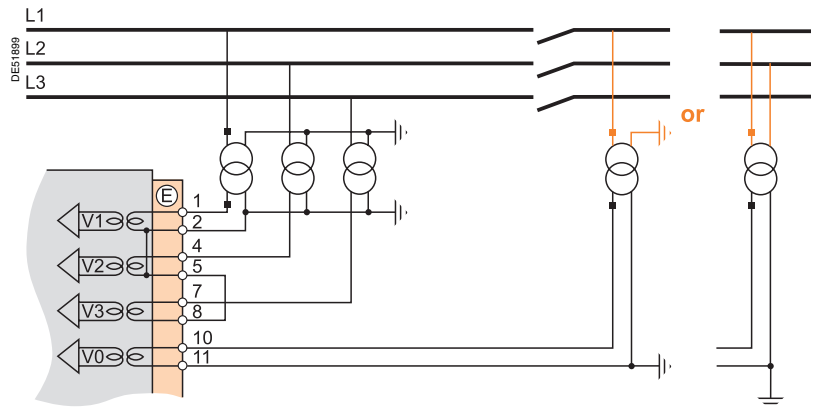

This connection should be used to measure:

- three phase-to-neutral voltages V1, V2, V3 on busbars no. 1
- one additional phase-to-neutral voltage V'1 (or one additional phase-to-phase voltage U'21) on busbars no. 2.

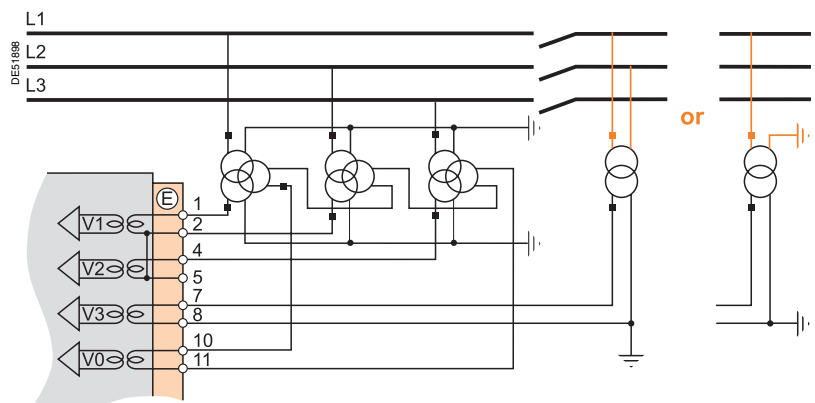

This connection should be used to measure:

- two phase-to-phase voltages U21, U32 and one residual voltage V0 on busbars no. 1
- one additional phase-to-phase voltage U'21 (or one additional phase-to-neutral voltage V'1) on busbars no. 2.

Base unit

Functions available according to connected voltage inputs

The availability of certain protection and metering functions depend on the phase and residual voltages measured by Sepam.

The table below gives the voltage input connection variants for which for each protection and metering function dependent on measured voltages is available. Example:

The directional overcurrent protection function (ANSI 67N/67NC) uses residual voltage V0 as a polarization value.

It is therefore operational in the following cases:

- measurement of the 3 phase-to-neutral voltages and calculation of $V0\Sigma$ (3 V + $V0\Sigma$, variant 1)
- measurement of residual voltage V0 (variant 5).

The protection and metering functions which do not appear in the table below are available regardless of the voltages measured.

Phase voltages measured (connection variant)		3 V + $V0\Sigma$ (var. 1)			2 U (var. 2)		1 U (var. 3)		1 V (var. 4)				
Residual voltage measured (connection variant)		-	V0 (v. 5)	Vnt (v. 6)	-	V0 (v. 5)	Vnt (v. 6)	-	V0 (v. 5)	Vnt (v. 6)	-	V0 (v. 5)	Vnt (v. 6)
Protection functions dependent on voltages measured													
Directional phase overcurrent	67	■	■	■	■	■	■						
Directional earth fault	67N/67NC	■	■	■		■		■				■	
Directional active overpower	32P	■	■	■	■	■	■						
Directional reactive active overpower	32Q	■	■	■	■	■	■						
Directional active underpower	37P	■	■	■	■	■	■						
Field loss (underimpedance)	40	■	■	■	■	■	■						
Pole slip, phase shift	78PS	■	■	■	■	■	■						
Voltage-restrained overcurrent	50V/51V	■	■	■	■	■	■						
Underimpedance	21B	■	■	■	■	■	■						
Inadvertent energization	50/27	■	■	■	■	■	■						
100 % stator earth fault	64G2/27TN			■			■						
Overfluxing (V/Hz)	24	■	■	■	■	■	■	■	■	■	■	■	■
Positive sequence undervoltage	27D	■ □	■ □	■	■ □	■ □	■						
Remanent undervoltage	27R	■ □	■ □	■	■ □	■ □	■	■ □ ☒	■ □	■	■ □ ☒	■ □	■
Undervoltage (L-L or L-N)	27	■ □	■ □	■	■ □	■ □	■	■ □ ☒	■ □	■	■ □ ☒	■ □	■
Overvoltage (L-L or L-N)	59	■ □	■ □	■	■ □	■ □	■	■ □ ☒	■ □	■	■ □ ☒	■ □	■
Neutral voltage displacement	59N	■ □	■ □	■		■ □	■		■ □	■		■ □	■
Negative sequence overvoltage	47	■ □	■ □	■	■	■ □	■					■ □	■
Overfrequency	81H	■ □	■ □	■	■ □	■ □	■	■ □ ☒	■ □	■	■ □ ☒	■ □	■
Underfrequency	81L	■ □	■ □	■	■ □	■ □	■	■ □ ☒	■ □	■	■ □ ☒	■ □	■
Rate of change of frequency	81R	■	■	■	■	■	■						
Measurements dependent on voltages measured													
Phase-to-phase voltage U21, U32, U13 or U'21, U'32, U'13		■ □	■ □	■	■ □	■ □	■ □	U21, U'21	U21	U21			
Phase-to-neutral voltage V1, V2, V3 or V'1, V'2, V'3		■ □	■ □	■		■					V1, V'1	V1, V'1	V1
Residual voltage V0 or V'0		■ □	■ □	■		■ □			■ □			■ □	
Neutral point voltage Vnt				■			■			■			■
Third harmonic neutral point or residual voltage				■			■			■			■
Positive sequence voltage Vd or V'd / negative sequence voltage Vi or V'i		■ □	■ □	■	■ □	■ □	■						
Frequency		■ □	■ □	■ □	■ □	■ □	■ □	■ □ ☒	■ □	■ □	■ □ ☒	■ □	■ □
Active / reactive / apparent power: P, Q, S		■	■	■	■	■	■	■	■	■			
Peak demand power PM, QM		■	■	■	■	■	■	■	■	■			
Active / reactive / apparent power per phase: P1/P2/P3, Q1/Q2/Q3, S1/S2/S3		■ (1)	■ (1)	■ (1)		■ (1)					P1/Q1/S1	P1/Q1/S1	P1/Q1/S1
Power factor		■	■	■	■	■	■	■	■	■			
Calculated active and reactive energy (±Wh, ±VARh)		■	■	■	■	■	■	■	■	■			
Total harmonic distortion, voltage Uthd		■	■	■	■	■	■	■	■	■			
Phase displacement $\varphi_0, \varphi'0$		■	■	■	■	■	■		■			■	
Phase displacement $\varphi_1, \varphi_2, \varphi_3$		■	■	■	■	■	■						
Apparent positive sequence impedance Zd		■	■	■	■	■	■						
Apparent phase-to-phase impedances Z21, Z32, Z13		■	■	■	■	■	■						

■ Function available on main voltage channels.
 □ Function available on Sepam B83 additional voltage channels.
 ☒ Function available on Sepam B80 additional voltage channel, according to the type of the additional voltage measured.
 (1) If all three phase currents are measured.

08P731N



ARJA1.

08P733N



ARJP3.

Function

Sepam may be connected to any standard 1 A or 5 A current transformer. Schneider Electric offers a range of current transformers to measure primary currents from 50 A to 2500 A. Consult us for more information.

Sizing of current transformers

Current transformers are sized so as not to be saturated by the current values they are required to measure accurately (minimum 5 In).

For overcurrent protection functions

- with DT tripping curve:
the saturation current must be 1.5 times greater than the setting
- with IDMT tripping curve:
the saturation current must be 1.5 times greater than the highest working value on the curve.

Practical solution when there is no information on the settings

Rated secondary current (in)	Accuracy burden	Accuracy class	CT secondary resistance R _{CT}	Wiring resistance R _f
1 A	2.5 VA	5P 20	< 3 Ω	< 0.075 Ω
5 A	7.5 VA	5P 20	< 0.2 Ω	< 0.075 Ω

For earth fault protection functions

Transformer and transformer-machine unit differential protection (ANSI 87T)

The phase current transformer primary currents must comply with the following rule:

$$0,1 \cdot \frac{S}{\sqrt{3} U n1} \leq I_n \leq 2,5 \cdot \frac{S}{\sqrt{3} U n1} \text{ for winding 1}$$

$$0,1 \cdot \frac{S}{\sqrt{3} U n2} \leq I'n \leq 2,5 \cdot \frac{S}{\sqrt{3} U n2} \text{ for winding 2.}$$

S is the transformer rated power.

In and I'n are the phase CT primary currents of winding 1 and 2 respectively.

Un1 and Un2 are the voltages of windings 1 and 2 respectively.

If the transformer peak inrush current (\hat{i}_{inrush}) is less than $6.7 \times \sqrt{2} \times I_n$, the current transformers must be either:

- type 5P20, with an accuracy burden $V_{Act} \geq R_w \cdot I_n^2$
- or defined by a knee-point voltage $V_k \geq (R_{CT} + R_w) \cdot 20 \cdot I_n$.

If the transformer peak inrush current (\hat{i}_{inrush}) is greater than $6.7 \times \sqrt{2} \times I_n$, the current transformers must be either:

- type 5P, with an accuracy-limit factor $\geq 3 \cdot \frac{\hat{i}_{inrush}}{\sqrt{2} \cdot I_n}$ and an accuracy burden $V_{Act} \geq R_w \cdot I_n^2$
- or defined by a knee-point voltage $V_k \geq (R_{CT} + R_w) \cdot 3 \cdot \frac{\hat{i}_{inrush}}{\sqrt{2} \cdot I_n} \cdot I_n$.

The equations apply to the phase current transformers of windings 1 and 2.

In and in are the CT rated primary and secondary currents respectively.

R_{CT} is the CT internal resistance.

R_w is the resistance of the CT load and wiring.

Machine differential (ANSI 87M)

Current transformers must be either:

- type 5P20, with an accuracy burden $V_{Act} \geq R_w \cdot I_n^2$
- or defined by a knee-point voltage $V_k \geq (R_{CT} + R_w) \cdot 20 \cdot I_n$.

The equations apply to the phase current transformers placed on either side of the machine.

I_n is the CT rated secondary current.

R_{CT} is the CT internal resistance.

R_w is the resistance of the CT load and wiring.

Restricted earth fault differential protection (ANSI 64REF)

■ the primary current of the neutral point current transformer used must comply with the following rule:

$0.1 I_n \leq \text{neutral point CT primary current} \leq 2 I_n$

with I_n = primary current of phase CTs on the same winding

Current transformers must be either:

■ type 5P, with an accuracy-limit factor $\geq \max. \left(20; 1,6 \frac{I_{3P}}{I_n}; 2,4 \frac{I_{1P}}{I_n} \right)$ and an accuracy burden $V_{Act} \geq R_w \cdot I_n^2$

■ or defined by a knee-point voltage $V_k \geq (R_{CT} + R_w) \cdot \max. \left(20; 1,6 \frac{I_{3P}}{I_n}; 2,4 \frac{I_{1P}}{I_n} \right) \cdot I_n$.

The equations apply to the phase current transformers and the neutral-point current transformer.

I_n is the CT rated secondary current.

R_{CT} is the CT internal resistance.

R_w is the resistance of the CT load and wiring.

I_{3P} is the maximum current value for a three-phase short-circuit.

I_{1P} is the maximum current value for a phase-to-earth short-circuit.

CCA630/CCA634 connector

Function

The current transformers (1 A or 5 A) are connected to the CCA630 or CCA634 connector on the rear panel of Sepam:

■ The CCA630 connector is used to connect three phase current transformers to Sepam.

■ The CCA634 connector is used to connect three phase current transformers and one residual current transformer to Sepam.

The CCA630 and CCA634 connectors contain interposing ring CTs with through primaries, which ensure impedance matching and isolation between the 1 A or 5 A circuits and Sepam when measuring phase and residual currents.

The connectors can be disconnected with the power on since disconnection does not open the CT secondary circuit.

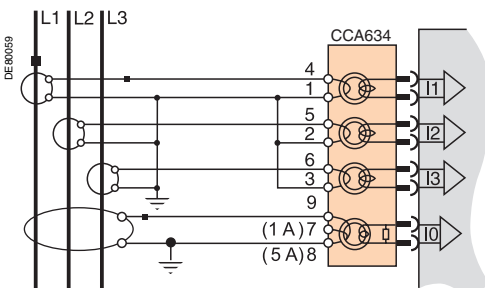
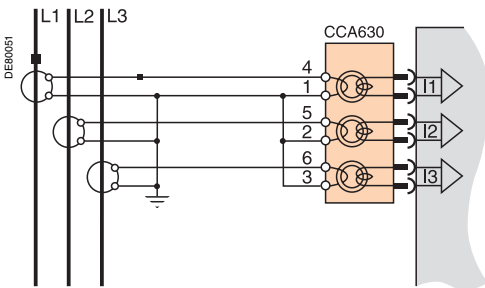

⚠ DANGER

HAZARD OF ELECTRIC SHOCK, ELECTRIC ARC OR BURNS

■ Only qualified personnel should install this equipment. Such work should be performed only after reading this entire set of instructions and checking the technical characteristics of the device.

■ NEVER work alone.

■ Turn off all power supplying this equipment before working on or inside it. Consider all sources of power, including the possibility of backfeeding.

■ Always use a properly rated voltage sensing device to confirm that all power is off.

■ To disconnect the Sepam unit current inputs, unplug the CCA630 or CCA634 connector without disconnecting the wires from it. The CCA630 and CCA634 connectors ensure continuity of the current transformer secondary circuits.

■ Before disconnecting the wires connected to the CCA630 or CCA634 connector, short-circuit the current transformer secondary circuits.

Failure to follow these instructions will result in death or serious injury.

MT10480

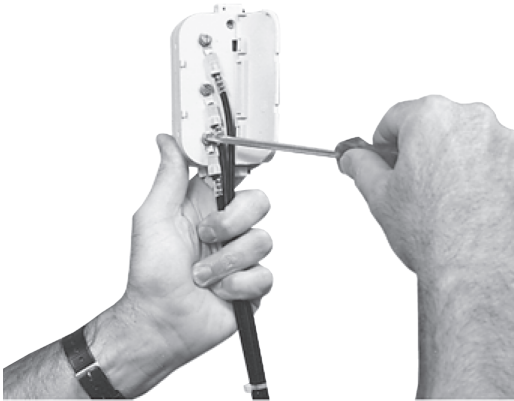

Connecting and assembling the CCA630 connector

1. Open the 2 side shields for access to the connection terminals. The shields can be removed, if necessary, to make wiring easier. If removed, they must be replaced after wiring.
2. If necessary, remove the bridging strap linking terminals 1, 2 and 3. This strap is supplied with the CCA630.
3. Connect the wires using 4 mm (0.16 in) ring lugs and check the tightness of the 6 screws that guarantee the continuity of the CT secondary circuits.
The connector accommodates wires with cross-sections of 1.5 to 6 mm² (AWG 16-10).
4. Close the side shields.
5. Plug the connector into the 9-pin inlet on the rear panel (item **B**).
6. Tighten the 2 CCA630 connector fastening screws on the rear panel of Sepam.

DEB0068

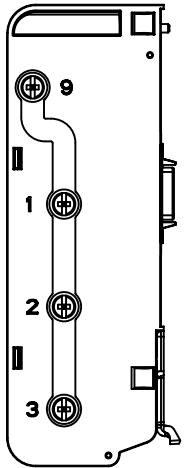

Bridging of terminals 1, 2, 3 and 9

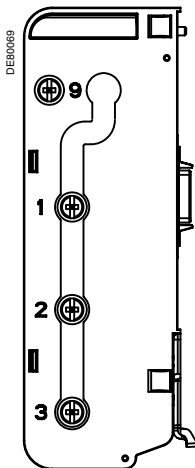

Bridging of terminals 1, 2 and 3

Connecting and assembling the CCA634 connector

1. Open the 2 side shields for access to the connection terminals. The shields can be removed, if necessary, to make wiring easier. If removed, they must be replaced after wiring.
2. According to the wiring required, remove or reverse the bridging strap. This is used to link either terminals 1, 2 and 3, or terminals 1, 2, 3 and 9 (see picture opposite).
3. Use terminal 7 (1 A) or 8 (5 A) to measure the residual current according to the CT secondary.
4. Connect the wires using 4 mm (0.16 in) ring lugs and check the tightness of the 6 screws that guarantee the continuity of the CT secondary circuits.
The connector accommodates wires with cross-sections of 1.5 to 6 mm² (AWG 16-10).
The wires only exit from the base.
5. Close the side shields.
6. Insert the connector pins into the slots on the base unit.
7. Flatten the connector against the unit to plug it into the 9-pin SUB-D connector (principle similar to that of the MES module).
8. Tighten the mounting screw.

⚠ CAUTION

HAZARD OF IMPROPER OPERATION

- Do not use a CCA634 on connector B1 and residual current input I0 on connector E (terminals 14 and 15) simultaneously. Even if it is not connected to a sensor, a CCA634 on connector B1 will disturb input I0 on connector E.
- Do not use a CCA634 on connector B2 and residual current input I'0 on connector E (terminals 17 and 18) simultaneously. Even if it is not connected to a sensor, a CCA634 on connector B2 will disturb input I'0 on connector E.

Failure to follow this instruction can cause equipment damage.

PE50031



CLP1 LPCT sensor

Function

Low Power Current Transducer (LPCT) type sensors are voltage-output sensors, which are compliant with the IEC 60044-8 standard. The Schneider Electric range of LPCTs includes the following sensors: CLP1, CLP2, CLP3, TLP160 and TLP190.

CCA670/CCA671 connector

Function

The 3 LPCT sensors are connected to the CCA670 or CCA671 connector on the rear panel of Sepam.

The connection of only one or two LPCT sensors is not allowed and causes Sepam to go into fail-safe position.

The two CCA670 and CCA671 interface connectors serve the same purpose, the difference being the position of the LPCT sensor plugs:

- CCA670: lateral plugs, for Sepam series 20 and Sepam series 40
- CCA671: radial plugs, for Sepam series 80.

Description

- 1 3 RJ45 plugs to connect the LPCT sensors.
- 2 3 blocks of microswitches to set the CCA670/CCA671 to the rated phase current value.
- 3 Microswitch setting/selected rated current equivalency table (2 In values per position).
- 4 9-pin sub-D connector to connect test equipment (ACE917 for direct connector or via CCA613).

Rating of CCA670/CCA671 connectors

The CCA670/CCA671 connector must be rated according to the rated primary current I_n measured by the LPCT sensors. I_n is the current value that corresponds to the rated secondary current of 22.5 mV. The possible settings for I_n are (in A): 25, 50, 100, 125, 133, 200, 250, 320, 400, 500, 630, 666, 1000, 1600, 2000, 3150.

The selected I_n value should be:

- entered as a Sepam general setting
- configured by microswitch on the CCA670/CCA671 connector.

Operating mode:

1. Use a screwdriver to remove the shield located in the "LPCT settings" zone; the shield protects 3 blocks of 8 microswitches marked L1, L2, L3.
2. On the L1 block, set the microswitch for the selected rated current to "1" (2 I_n values per microswitch).
 - The table of equivalencies between the microswitch settings and the selected rated current I_n is printed on the connector
 - Leave the 7 other microswitches set to "0".
3. Set the other 2 blocks of switches L2 and L3 to the same position as the L1 block and close the shield.

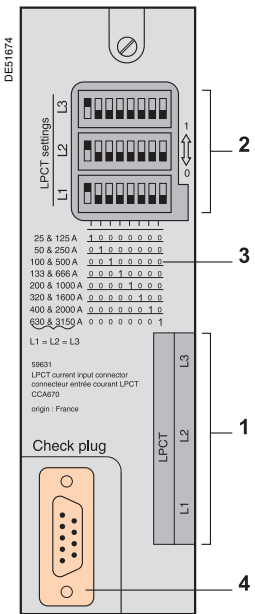

CAUTION

HAZARD OF NON-OPERATION

- Set the microswitches for the CCA670/CCA671 connector before commissioning the device.
- Check that only one microswitch is in position 1 for each block L1, L2, L3 and that no microswitch is in the center position.
- Check that the microswitch settings on all 3 blocks are identical.

Failure to follow these instructions can cause incorrect operation.

Accessory connection principle

⚠ DANGER

HAZARD OF ELECTRIC SHOCK, ELECTRIC ARC OR BURNS

- Only qualified personnel should install this equipment. Such work should be performed only after reading this entire set of instructions.
- NEVER work alone.
- Turn off all power supplying this equipment before working on or inside it. Consider all sources of power, including the possibility of backfeeding.
- Always use a properly rated voltage sensing device to confirm that all power is off.

Failure to follow these instructions will result in death or serious injury.

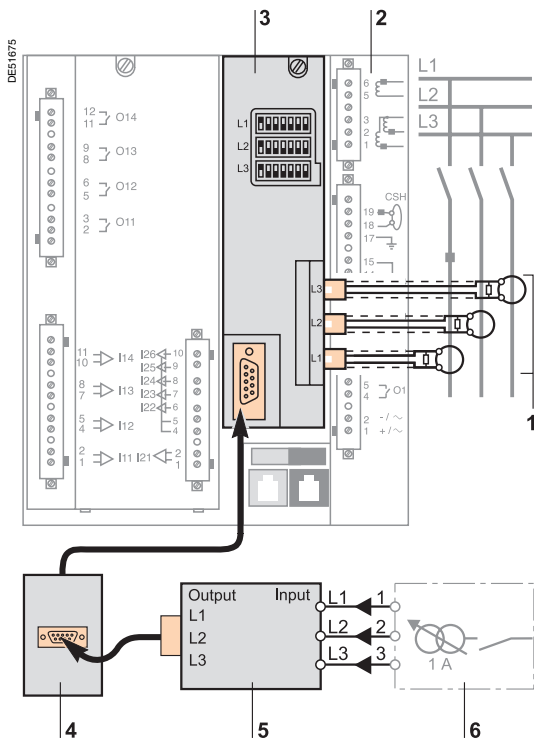

- 1 LPCT sensor, equipped with a shielded cable fitted with a yellow RJ 45 plug which is plugged directly into the CCA670/CCA671 connector.
- 2 Sepam protection unit.
- 3 CCA670/CCA671 connector, LPCT voltage interface, with microswitch setting of rated current:
 - CCA670: lateral plugs for Sepam series 20 and Sepam series 40
 - CCA671: radial plugs for Sepam series 80.
- 4 CCA613 remote test plug, flush-mounted on the front of the cubicle and equipped with a 3-meter (9.8 ft) cord to be plugged into the test plug of the CCA670/CCA671 interface connector (9-pin sub-D).
- 5 ACE917 injection adapter, to test the LPCT protection chain with a standard injection box.
- 6 Standard injection box.

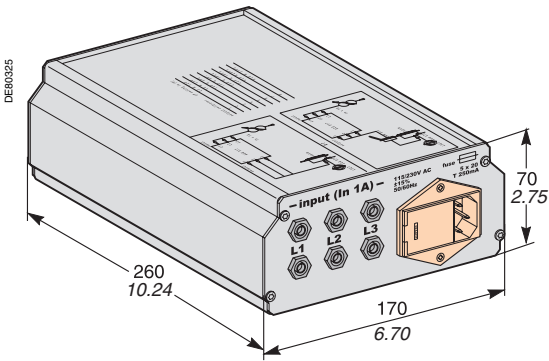

ACE917 injection adapter

Function

The ACE917 adapter is used to test the protection chain with a standard injection box, when Sepam is connected to LPCT sensors.

The ACE917 adapter is inserted between:

- The standard injection box
- The LPCT test plug:
 - integrated in the Sepam CCA670/CCA671 interface connector
 - or transferred by means of the CCA613 accessory.

The following are supplied with the ACE917 injection adapter:

- Power supply cord
- 3-meter (9.8 ft) cord to connect the ACE917 to the LPCT test plug on CCA670/CCA671 or CCA613.

Characteristics

Power supply	115/230 V AC
Protection by time-delayed fuse 5 mm x 20 mm (0.2 x 0.79 in)	0.25 A rating

CCA613 remote test plug

Function

The CCA613 test plug, flush-mounted on the front of the cubicle, is equipped with a 3-meter (9.8 ft) cord to transfer data from the test plug integrated in the CCA670/CCA671 interface connector on the rear panel of Sepam.

Dimensions

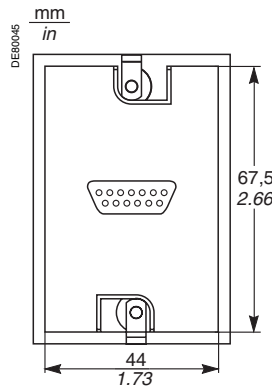

Front view with cover lifted.

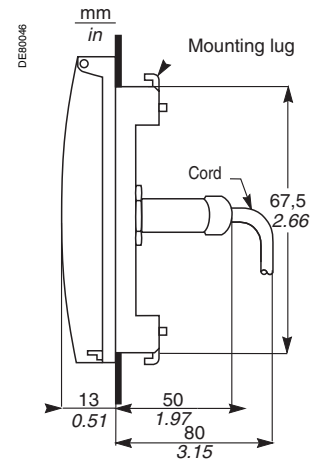

Right side view.

⚠ CAUTION

HAZARD OF CUTS
Trim the edges of the cut-out plates to remove any jagged edges.
Failure to follow this instruction can cause serious injury.

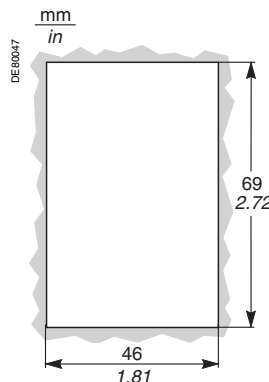

Cut-out.

CSH120 and CSH200 Core balance CTs

1

PE50028



CSH120 and CSH200 core balance CTs.

Function

The specifically designed CSH120 and CSH200 core balance CTs are for direct residual current measurement. The only difference between them is the diameter. Due to their low voltage insulation, they can only be used on cables.

Note: The CSH280 core balance CT available in the Motorpact offer is compatible with Sepam.

Characteristics

		CSH120	CSH200
Inner diameter		120 mm (4.7 in)	196 mm (7.72 in)
Weight		0.6 kg (1.32 lb)	1.4 kg (3.09 lb)
Accuracy	1 CT	±5% at 20°C (68°F) ±6% max. from -25°C to 70°C (-13°F to +158°F)	
	2 CTs in parallel	-	±10%
Transformation ratio		1/470	
Maximum permissible current	1 CT	20 kA - 1 s	
	2 CTs in parallel	-	6 kA - 1 s
Operating temperature		-25°C to +70°C (-13°F to +158°F)	
Storage temperature		-40°C to +85°C (-40°F to +185°F)	

Dimensions

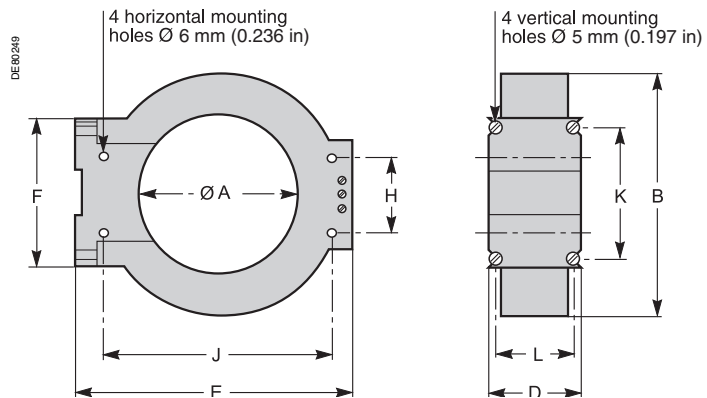

Dimensions	A	B	D	E	F	H	J	K	L
CSH120 (in)	120 (4.75)	164 (6.46)	44 (1.73)	190 (7.48)	80 (3.15)	40 (1.57)	166 (6.54)	65 (2.56)	35 (1.38)
CSH200 (in)	196 (7.72)	256 (10.1)	46 (1.81)	274 (10.8)	120 (4.72)	60 (2.36)	254 (10)	104 (4.09)	37 (1.46)

⚠ DANGER

HAZARD OF ELECTRIC SHOCK, ELECTRIC ARC OR BURNS

- Only qualified personnel should install this equipment. Such work should be performed only after reading this entire set of instructions and checking the technical characteristics of the device.
 - NEVER work alone.
 - Turn off all power supplying this equipment before working on or inside it. Consider all sources of power, including the possibility of backfeeding.
 - Always use a properly rated voltage sensing device to confirm that all power is off.
 - Only CSH120, CSH200 and CSH280 core balance CTs can be used for direct residual current measurement. Other residual current sensors require the use of an intermediate device, CSH30, ACE990 or CCA634.
 - Install the core balance CTs on insulated cables.
 - Cables with a rated voltage of more than 1000 V must also have an earthed shielding.
- Failure to follow these instructions will result in death or serious injury.**

Assembly

Group the MV cable (or cables) in the middle of the core balance CT. Use non-conductive binding to hold the cables. Remember to insert the 3 medium voltage cable shielding earthing cables through the core balance CT.

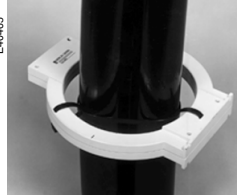
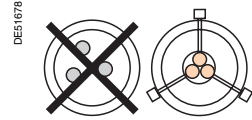

Assembly on MV cables.

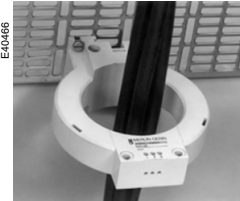

Assembly on mounting plate.

⚠ CAUTION

HAZARD OF NON-OPERATION

Do not connect the secondary circuit of the CSH core balance CTs to earth. This connection is made in Sepam. **Failure to follow this instruction can cause Sepam to operate incorrectly.**

Connection

Connection to Sepam series 20 and Sepam series 40

To residual current I0 input, on connector (A), terminals 19 and 18 (shielding)

Connection to Sepam series 80

- To residual current I0 input, on connector (E), terminals 15 and 14 (shielding)
- To residual current I'0 input, on connector (E), terminals 18 and 17 (shielding)

Recommended cable

- Sheathed cable, shielded by tinned copper braid
 - Minimum cable cross-section 0.93 mm² (AWG 18)
 - Resistance per unit length < 100 mΩ/m (30.5 mΩ/ft)
 - Minimum dielectric strength: 1000 V (700 Vrms)
 - Connect the cable shielding in the shortest manner possible to Sepam
 - Flatten the connection cable against the metal frames of the cubicle. The connection cable shielding is grounded in Sepam. Do not ground the cable by any other means.
- The maximum resistance of the Sepam connection wiring must not exceed 4 Ω (i.e. 20 m maximum for 100 mΩ/m or 66 ft maximum for 30.5 mΩ/ft).**

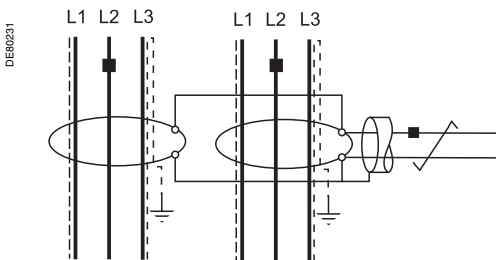
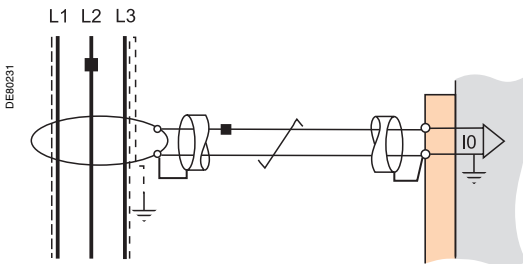

Connecting 2 CSH200 CTs in parallel

It is possible to connect 2 CSH200 CTs in parallel if the cables will not fit through a single CT, by following the instructions below:

- Fit one CT per set of cables.
- Make sure the wiring polarity is correct.

The maximum permissible current at the primary is limited to 6 kA - 1 s for all cables.

1

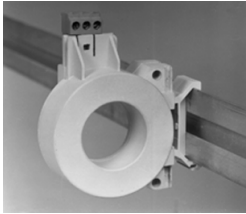

Vertical assembly of CSH30 interposing ring CT.

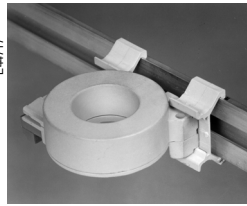

Horizontal assembly of CSH30 interposing ring CT.

Function

The CSH30 interposing ring CT is used as an interface when the residual current is measured using 1 A or 5 A current transformers.

Characteristics

Weight	0.12 kg (0.265 lb)
Assembly	On symmetrical DIN rail In vertical or horizontal position

Dimensions

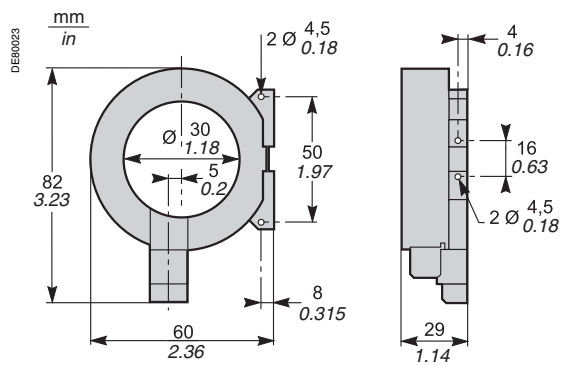

Connection

The CSH30 is adapted for the type of current transformer, 1 A or 5 A, by the number of turns of the secondary wiring through the CSH30 interposing ring CT:

- 5 A rating - 4 turns
- 1 A rating - 2 turns

Connection to 5 A secondary circuit

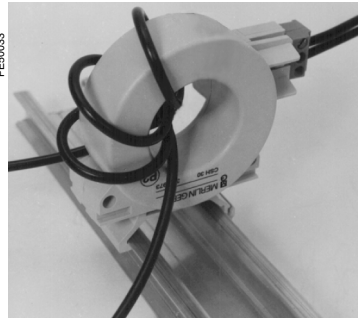

1. Plug into the connector.
2. Insert the transformer secondary wire through the CSH30 interposing ring CT 4 times.

Connection to 1 A secondary circuit

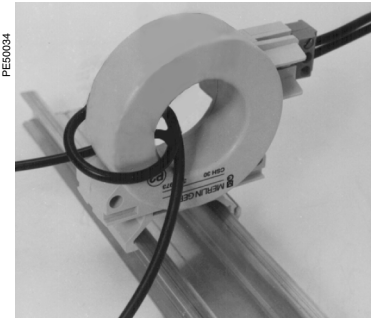

1. Plug into the connector.
2. Insert the transformer secondary wire through the CSH30 interposing ring CT twice.

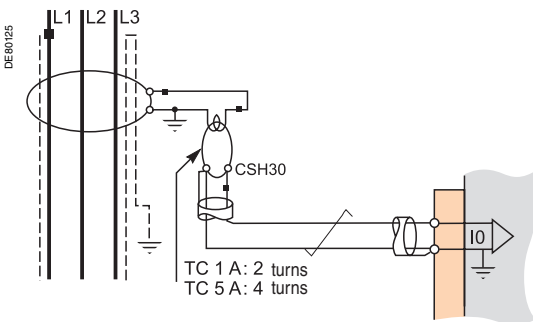

Connection to Sepam series 20 and Sepam series 40

To residual current I0 input, on connector (A), terminals 19 and 18 (shielding)

Connection to Sepam series 80

- To residual current I0 input, on connector (E), terminals 15 and 14 (shielding)
- To residual current I'0 input, on connector (E), terminals 18 and 17 (shielding)

Recommended cable

- Sheathed cable, shielded by tinned copper braid
- Minimum cable cross-section 0.93 mm² (AWG 18) (max. 2.5 mm², AWG 12)
- Resistance per unit length < 100 mΩ/m (30.5 mΩ/ft)
- Minimum dielectric strength: 1000 V (700 Vrms)
- Maximum length: 2 m (6.6 ft).

It is essential for the CSH30 interposing ring CT to be installed near Sepam (Sepam - CSH30 link less than 2 m (6.6 ft) long).

Flatten the connection cable against the metal frames of the cubicle.

The connection cable shielding is grounded in Sepam. Do not ground the cable by any other means.

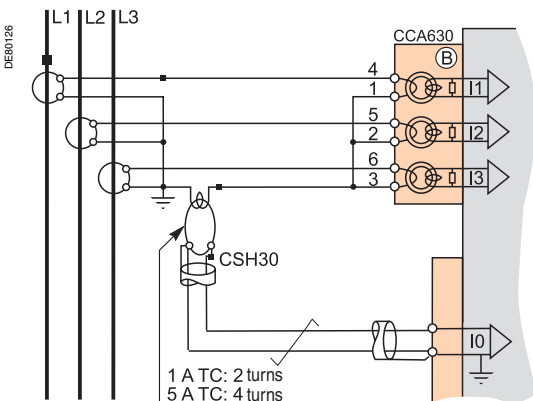

1

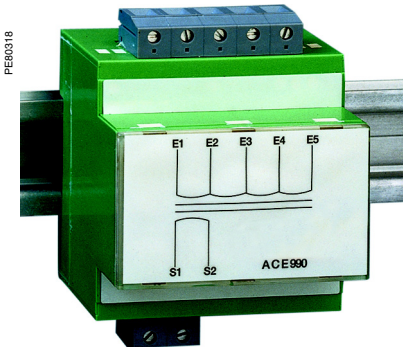

ACE990 core balance CT interface.

Function

The ACE990 is used to adapt measurements between an MV core balance CT with a ratio of 1/n ($50 \leq n \leq 1500$), and the Sepam residual current input.

Characteristics

Weight	0.64 kg (1.41 lb)
Assembly	Mounted on symmetrical DIN rail
Amplitude accuracy	±1%
Phase accuracy	< 2°
Maximum permissible current	20 kA - 1 s (on the primary winding of an MV core balance CT with a ratio of 1/50 that does not saturate)
Operating temperature	-5°C to +55°C (+23°F to +131°F)
Storage temperature	-25°C to +70°C (-13°F to +158°F)

Description and dimensions

- Ⓔ ACE990 input terminal block, for connection of the core balance CT.
- Ⓕ ACE990 output terminal block, for connection of the Sepam residual current.

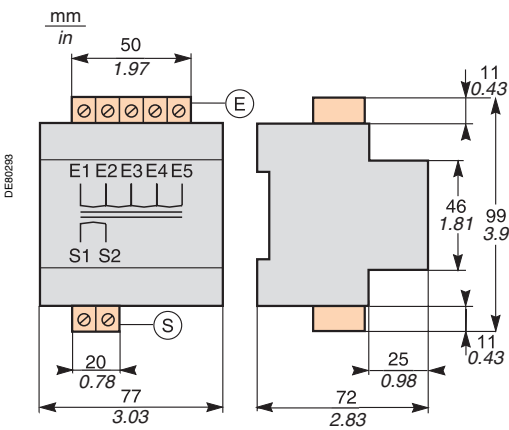

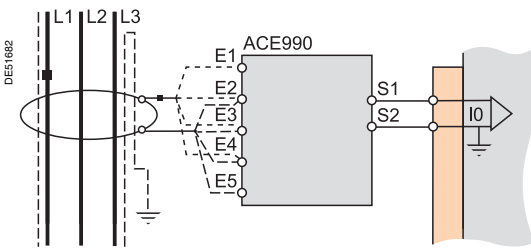

Connection

Connection of core balance CT

Only one core balance CT can be connected to the ACE990 interface. The secondary circuit of the MV core balance CT is connected to 2 of the 5 ACE990 interface input terminals. To define the 2 input terminals, it is necessary to know the following:

- Core balance CT ratio (1/n)
- Core balance CT power
- Close approximation of rated current I_{n0} (I_{n0} is a general setting in Sepam and defines the earth fault protection setting range between $0.1 I_{n0}$ and $15 I_{n0}$).

The table below can be used to determine:

- The 2 ACE990 input terminals to be connected to the MV core balance CT secondary
- The type of residual current sensor to set
- The exact value of the rated residual current I_{n0} setting, given by the following formula: $I_{n0} = k \times \text{number of core balance CT turns}$ with k the factor defined in the table below.

The core balance CT must be connected to the interface in the right direction for correct operation: the MV core balance CT secondary output terminal S1 must be connected to the terminal with the lowest index (Ex).

Example:

Given a core balance CT with a ratio of 1/400 2 VA, used within a measurement range of 0.5 A to 60 A.

How should it be connected to Sepam via the ACE990?

1. Choose a close approximation of the rated current I_{n0} , i.e. 5 A.
2. Calculate the ratio:
approx. $I_{n0}/\text{number of turns} = 5/400 = 0.0125$.
3. Find the closest value of k in the table opposite to $k = 0.01136$.
4. Check the minimum power required for the core balance CT: 2 VA core balance CT > 0.1 VA ✓ OK.
5. Connect the core balance CT secondary to ACE990 input terminals E2 and E4.
6. Set Sepam up with:
 $I_{n0} = 0.01136 \times 400 = 4.5 \text{ A}$.

This value of I_{n0} can be used to monitor current between 0.45 A and 67.5 A.

Wiring of MV core balance CT secondary circuit.

- MV core balance CT S1 output to ACE990 E2 input terminal
- MV core balance CT S2 output to ACE990 E4 input terminal.

K value	ACE990 input terminals to be connected	Residual current sensor setting	Min. MV core balance CT power
0.00578	E1 - E5	ACE990 - range 1	0.1 VA
0.00676	E2 - E5	ACE990 - range 1	0.1 VA
0.00885	E1 - E4	ACE990 - range 1	0.1 VA
0.00909	E3 - E5	ACE990 - range 1	0.1 VA
0.01136	E2 - E4	ACE990 - range 1	0.1 VA
0.01587	E1 - E3	ACE990 - range 1	0.1 VA
0.01667	E4 - E5	ACE990 - range 1	0.1 VA
0.02000	E3 - E4	ACE990 - range 1	0.1 VA
0.02632	E2 - E3	ACE990 - range 1	0.1 VA
0.04000	E1 - E2	ACE990 - range 1	0.2 VA
0.05780	E1 - E5	ACE990 - range 2	2.5 VA
0.06757	E2 - E5	ACE990 - range 2	2.5 VA
0.08850	E1 - E4	ACE990 - range 2	3.0 VA
0.09091	E3 - E5	ACE990 - range 2	3.0 VA
0.11364	E2 - E4	ACE990 - range 2	3.0 VA
0.15873	E1 - E3	ACE990 - range 2	4.5 VA
0.16667	E4 - E5	ACE990 - range 2	4.5 VA
0.20000	E3 - E4	ACE990 - range 2	5.5 VA
0.26316	E2 - E3	ACE990 - range 2	7.5 VA

Connection to Sepam series 20 and Sepam series 40

To residual current I_0 input, on connector (A), terminals 19 and 18 (shielding)

Connection to Sepam series 80

- To residual current I_0 input, on connector (E), terminals 15 and 14 (shielding)
- To residual current I_0 input, on connector (E), terminals 18 and 17 (shielding)

Recommended cables

- Cable between core balance CT and ACE990: less than 50 m (160 ft) long
- Sheathed cable, shielded by tinned copper braid between the ACE990 and Sepam, maximum length 2 m (6.6 ft)
- Cable cross-section between 0.93 mm² (AWG 18) and 2.5 mm² (AWG 12)
- Resistance per unit length less than 100 mΩ/m (30.5 mΩ/ft)
- Minimum dielectric strength: 100 Vrms.

Connect the connection cable shielding in the shortest manner possible (2 cm or 5.08 in maximum) to the shielding terminal on the Sepam connector. Flatten the connection cable against the metal frames of the cubicle.

The connection cable shielding is grounded in Sepam. Do not ground the cable by any other means.

087734N



VRQ3 without fuses.

087735N



VRQ3 with fuses.

Function

Sepam may be connected to any standard voltage transformer with a rated secondary voltage of 100 V to 220 V.

Schneider Electric offers a range of voltage transformers

- to measure phase-to-neutral voltages: voltage transformers with one insulated MV terminal
- to measure phase-to-phase voltages: voltage transformers with two insulated MV terminals
- with or without integrated protection fuses.

Consult us for more information.

Connection

Main voltage inputs

All Sepam series 80 units have 4 main voltage inputs to measure 4 voltages, i.e. 3 phase voltages and residual voltage.

- The main voltage measurement VTs are connected to the Sepam connector (E).
- 4 transformers integrated in the Sepam base unit provide the required impedance matching and isolation between the VTs and the Sepam input circuits.

Additional voltage inputs

Sepam B83 units also have 4 additional voltage inputs to measure the voltages on a second set of busbars.

- The additional voltage measurement VTs are connected to the CCT640 connector which is mounted on the Sepam port (B2).
- The CCT640 connector contains the 4 transformers that provide the required impedance matching and isolation between the VTs and the Sepam input circuits (port (B2)).

CCT640 connector

Function

The CCT640 connector is used to connect the 4 additional voltages available in Sepam B83. It provides the required impedance matching and isolation between the VTs and the Sepam input circuits (port B2).

⚠ DANGER

HAZARD OF ELECTRIC SHOCK, ELECTRIC ARC OR BURNS

- Only qualified personnel should install this equipment. Such work should be performed only after reading this entire set of instructions and checking the technical characteristics of the device.
- NEVER work alone.
- Turn off all power supplying this equipment before working on or inside it. Consider all sources of power, including the possibility of backfeeding.
- Always use a properly rated voltage sensing device to confirm that all power is off.
- Start by connecting the device to the protective earth and to the functional earth.
- Screw tight all terminals, even those not in use.

Failure to follow these instructions will result in death or serious injury.

Assembly

- Insert the 3 connector pins into the slots ① on the base unit.
- Rotate connector to plug it into the 9-pin SUB-D connector
- Tighten the mounting screw ②.

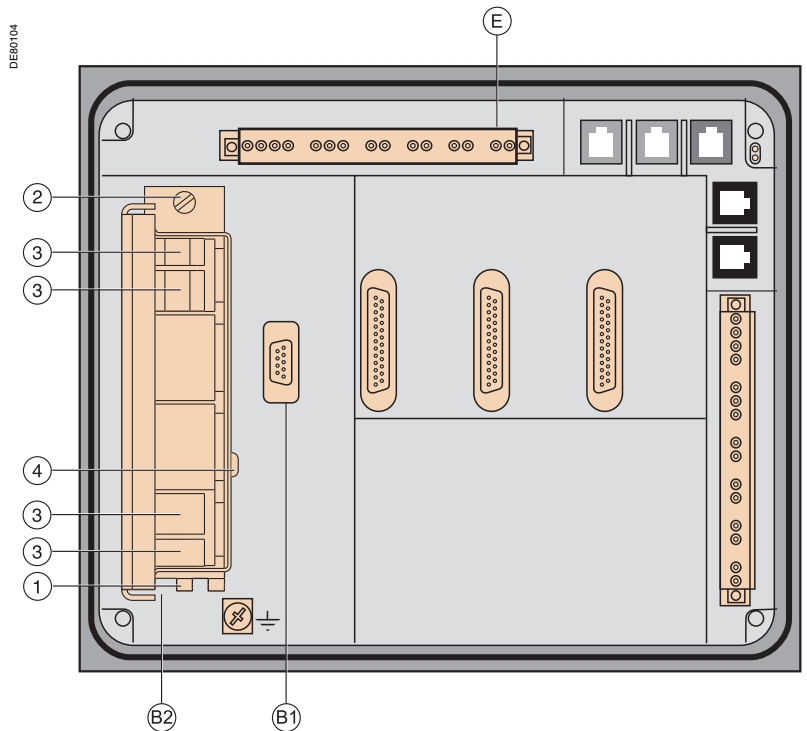

Connection

The connections are made to the screw-type connectors on the rear panel of the CCT640 (item ③).

Wiring without fittings

- 1 wire with maximum cross-section 0.2 to 2.5 mm² (≥ AWG 24-12) or 2 wires with maximum cross-section 0.2 to 1 mm² (≥ AWG 24-16)
- stripped length: 8 to 10 mm (0.31 to 0.39 in).

Wiring with fittings

- recommended wiring with Telemecanique fittings:
 - DZ5CE015D for one 1.5 mm² wire (AWG 16)
 - DZ5CE025D for one 2.5 mm² wire (AWG 12)
 - AZ5DE010D for two 1 mm² wires (AWG 18)
 - tube length: 8.2 mm (0.32 in)
 - stripped length: 8 mm (0.31 in).

Earthing

The CCT640 must be earthed by connection (green/yellow wire + ring lug) to the screw ④ (safety measure in case of disconnection of the CCT640).

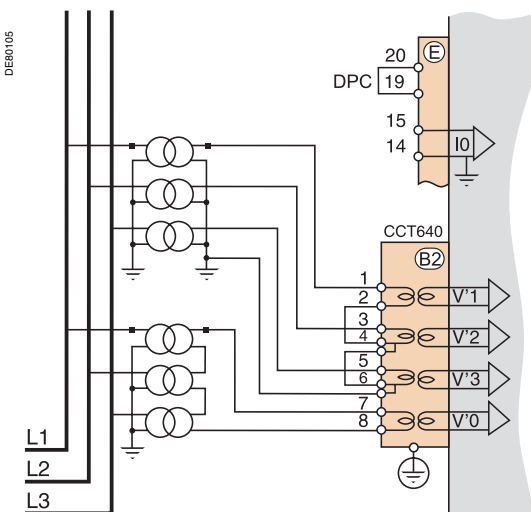

MES120, MES120G, MES120H 14 input / 6 output modules Presentation

1

PE6020

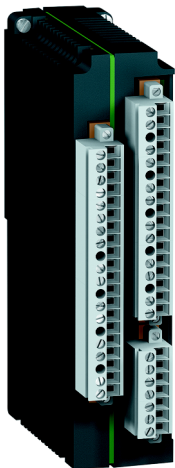

MES120 14 input / 6 output module.

Function

The 5 output relays included on the Sepam series 80 base unit may be extended by adding 1, 2 or 3 MES120 modules with 14 DC logic inputs and 6 outputs relays, 1 control relay output and 5 annunciation relay outputs.

Three modules are available for the different input supply voltage ranges and offer different switching thresholds:

- MES120, 14 inputs 24 V DC to 250 V DC with a typical switching threshold of 14 V DC
- MES120G, 14 inputs 220 V DC to 250 V DC with a typical switching threshold of 155 V DC.
- MES120H, 14 inputs 110 V DC to 125 V DC with a typical switching threshold of 82 V DC

Characteristics

MES120/MES120G/MES120H modules

Weight	0.38 kg (0.83 lb)		
Operating temperature	-25°C to +70°C (-13°F to +158°F)		
Environmental characteristics	Same characteristics as Sepam base units		

Logic inputs	MES120	MES120G	MES120H
Voltage	24 to 250 V DC	220 to 250 V DC	110 to 125 V DC
Range	19.2 to 275 V DC	170 to 275 V DC	88 to 150 V DC
Typical consumption	3 mA	3 mA	3 mA
Typical switching threshold	14 V DC	155 V DC	82 V DC
Input limit voltage	At state 0	< 6 V DC	< 144 V DC
	At state 1	> 19 V DC	> 170 V DC
Isolation of inputs from other isolated groups	Enhanced	Enhanced	Enhanced

Control relay output Ox01

Voltage	MES120		MES120G		MES120H	
	DC	24/48 V DC	127 V DC	220 V DC	250 V DC	-
AC (47.5 to 63 Hz)	-	-	-	-	100 to 240 V AC	
Continuous current	8 A	8 A	8 A	8 A	8 A	
Breaking capacity	Resistive load	8/4 A	0.7 A	0.3 A	0.2 A	8 A
	L/R load < 20 ms	6/2 A	0.5 A	0.2 A	-	-
	L/R load < 40 ms	4/1 A	0.2 A	0.1 A	-	-
	p.f. load > 0.3	-	-	-	-	5 A
Making capacity	< 15 A for 200 ms					
Isolation of outputs from other isolated groups	Enhanced					

Annunciation relay output Ox02 to Ox06

Voltage	MES120		MES120G		MES120H	
	DC	24/48 V DC	127 V DC	220 V DC	250 V DC	-
AC (47.5 to 63 Hz)	-	-	-	-	100 to 240 V AC	
Continuous current	2 A	2 A	2 A	-	2 A	
Breaking capacity	Resistive load	2/1 A	0.6 A	0.3 A	0.2 A	-
	L/R load < 20 ms	2/1 A	0.5 A	0.15 A	-	-
	p.f. load > 0.3	-	-	-	-	1 A
Isolation of outputs from other isolated groups	Enhanced					

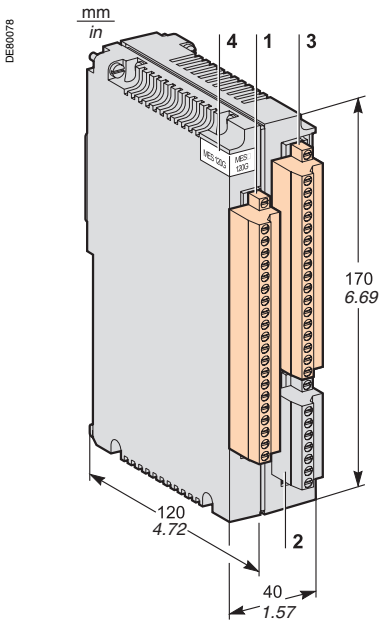

Installation of the second MES120 module, connected to base unit connector H2.

Description

3 removable, lockable screw-type connectors.

- 1 20-pin connector for 9 logic inputs:
 - Ix01 to Ix04: 4 independent logic inputs
 - Ix05 to Ix09: 5 common point logic inputs.
- 2 7-pin connector for 5 common point logic inputs Ix10 to Ix14.
- 3 17-pin connector for 6 relay outputs:
 - Ox01: 1 control relay output
 - Ox02 to Ox06: 5 annunciation relay outputs.

Addressing of MES120 module inputs / outputs:

- x = 1 for the module connected to H1
- x = 2 for the module connected to H2
- x = 3 for the module connected to H3.

- 4 MES120G, MES120H identification label (MES120 modules have no labels).

Assembly

Installation of an MES120 module on the base unit

- insert the 2 pins on the MES module into the slots 1 on the base unit
- push the module flat up against the base unit to plug it into the connector H2
- partially tighten the two mounting screws 2 before locking them.

MES120 modules must be mounted in the following order:

- if only one module is required, connect it to connector H1
- if 2 modules are required, connect them to connectors H1 and H2
- if 3 modules are required (maximum configuration), the 3 connectors H1, H2 and H3 are used.

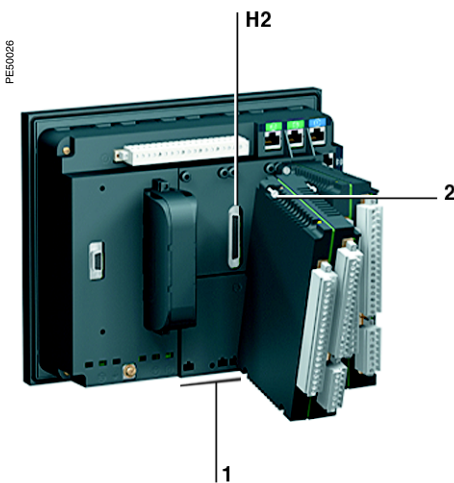

Installation of the second MES120 module, connected to base unit connector H2.

MES120, MES120G, MES120H

14 input / 6 output modules

Installation

1

Connection

The inputs are potential-free and the DC power supply source is external.

⚠ DANGER

HAZARD OF ELECTRIC SHOCK, ELECTRIC ARC OR BURNS

- Only qualified personnel should install this equipment. Such work should be performed only after reading this entire set of instructions and checking the technical characteristics of the device.
- NEVER work alone.
- Turn off all power supplying this equipment before working on or inside it. Consider all sources of power, including the possibility of backfeeding.
- Always use a properly rated voltage sensing device to confirm that all power is off.
- Screw tight all terminals, even those not in use.

Failure to follow these instructions will result in death or serious injury.

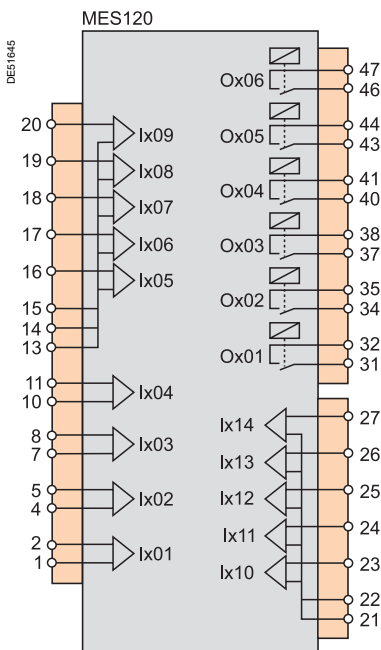

Wiring of connectors

- wiring without fittings:
 - 1 wire with maximum cross-section 0.2 to 2.5 mm² (≥ AWG 24-12)
 - or 2 wires with maximum cross-section 0.2 to 1 mm² (≥ AWG 24-16)
 - stripped length: 8 to 10 mm (0.31 to 0.39 in)
- wiring with fittings:
 - recommended wiring with Telemecanique fittings:
 - DZ5CE015D for one 1.5 mm² wire (AWG 16)
 - DZ5CE025D for one 2.5 mm² wire (AWG 12)
 - AZ5DE010D for two 1 mm² wires (AWG 18)
 - tube length: 8.2 mm (0.32 in)
 - stripped length: 8 mm (0.31 in).

Selection guide

4 remote modules are proposed as options to enhance the Sepam base unit functions:

- the number and type of remote modules compatible with the base unit depend on the Sepam application
- the DSM303 remote advanced UMI module is only compatible with base units that do not have integrated advanced UMIs.

			Sepam series 20		Sepam series 40		Sepam series 80		
			S2x, B2x	T2x, M2x	S4x	T4x, M4x, G4x	S8x, B8x	T8x, G8x	M8x C8x
MET148-2	Temperature sensor module	See page 44	0	1	0	2	0	2	2
MSA141	Analog output module	See page 46	1	1	1	1	1	1	1
DSM303	Remote advanced UMI module	See page 48	1	1	1	1	1	1	1
MCS025	Synchro-check module	See page 50	0	0	0	0	1	1	0
Number of sets of interlinked modules / maximum number of remote modules			1 set of 3 interlinked modules		1 set of 3 interlinked modules		5 modules split between 2 sets of interlinked modules		

Connection

Connection cords

Different combinations of modules may be connected using cords fitted with 2 black RJ45 connectors, which come in 3 lengths:

- CCA770: length = 0.6 m (2 ft)
- CCA772: length = 2 m (6.6 ft)
- CCA774: length = 4 m (13.1 ft).

The modules are linked by cords which provide the power supply and act as functional links with the Sepam unit (connector (D) to connector (Da), (Dd) to (Da), ...).

Rules on inter-module linking

- linking of 3 modules maximum
- DSM303 and MCS025 modules may only be connected at the end of the link.

Maximum advisable configurations

Sepam series 20 and Sepam series 40: just 1 set of interlinked modules

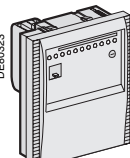
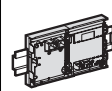
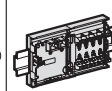
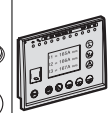
Base	Cord	Module 1	Cord	Module 2	Cord	Module 3
	(D) (Da)		(Dd) (Da)		(Dd) (D)	
series 20	CCA772	MSA141	CCA770	MET148-2	CCA774	DSM303
series 40	CCA772	MSA141	CCA770	MET148-2	CCA774	DSM303
series 40	CCA772	MSA141	CCA770	MET148-2	CCA772	MET148-2
series 40	CCA772	MET148-2	CCA770	MET148-2	CCA774	DSM303

Sepam series 80: 2 sets of interlinked modules

Sepam series 80 has 2 connection ports for remote modules, (D1) and (D2). Modules may be connected to either port.

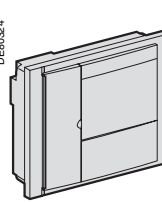
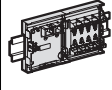
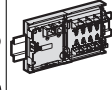
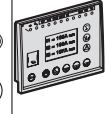
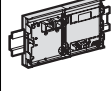
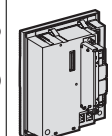
Base	Cord	Module 1	Cord	Module 2	Cord	Module 3
Set 1 (D1)	CCA772	MET148-2	CCA770	MET148-2	CCA774	DSM303
	(D1) (Da)		(Dd) (Da)		(Dd) (D)	
	(D2) (Da)		(Dd) (D)		-	-
Set 2 (D2)	CCA772	MSA141	CCA785	MCS025	-	-

CAUTION

HAZARD OF NON-OPERATION
The MCS025 module must ALWAYS be connected with the special CCA785 cord, supplied with the module and equipped with an orange RJ45 plug and a black RJ45 plug.
Failure to follow this instruction can cause equipment damage.

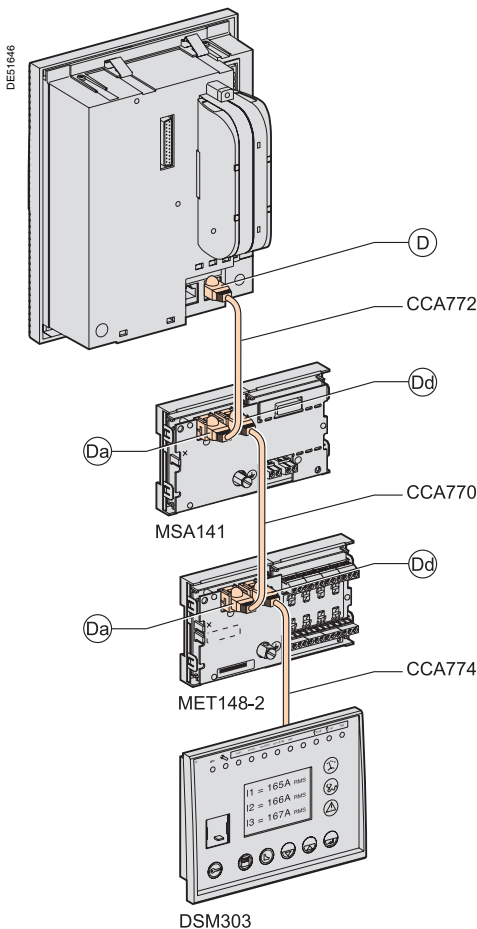

Example of inter-module linking on Sepam series 20.

MET148-2 Temperature sensor module

1

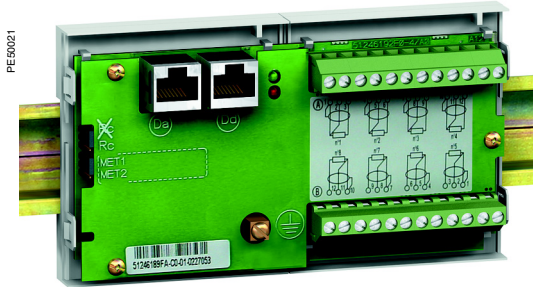

Function

The MET148-2 module can be used to connect 8 temperature sensors (RTDs) of the same type:

- Pt100, Ni100 or Ni120 type RTDs, according to parameter setting
- 3-wire temperature sensors
- A single module for each Sepam series 20 base unit, to be connected by one of the CCA770 (0.6 or 2 ft), CCA772 (2 m or 6.6 ft) or CCA774 (4 m or 13.1 ft) cords
- 2 modules for each Sepam series 40 or series 80 base unit, to be connected by CCA770 (0.6 or 2 ft), CCA772 (2 m or 6.6 ft) or CCA774 (4 m or 13.1 ft) cords

The temperature measurement (e.g. in a transformer or motor winding) is utilized by the following protection functions:

- Thermal overload (to take ambient temperature into account)
- Temperature monitoring.

Characteristics

MET148-2 module		
Weight	0.2 kg (0.441 lb)	
Assembly	On symmetrical DIN rail	
Operating temperature	-25°C to +70°C (-13°F to +158°F)	
Environmental characteristics	Same characteristics as Sepam base units	
Temperature sensors	Pt100	Ni100/Ni120
Isolation from earth	None	None
Current injected in RTD	4 mA	4 mA

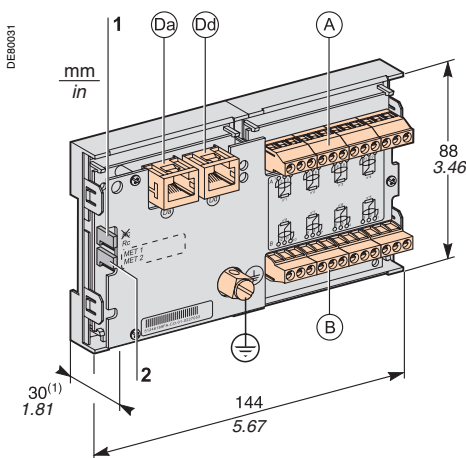

(1) 70 mm (2.8 in) with CCA77x cord connected.

Description and dimensions

- (A) Terminal block for RTDs 1 to 4
- (B) Terminal block for RTDs 5 to 8
- (Da) RJ45 connector to connect the module to the base unit with a CCA77x cord
- (Dd) RJ45 connector to link up the next remote module with a CCA77x cord (according to application)
- (⊕) Grounding/earthing terminal

- 1 Jumper for impedance matching with load resistor (Rc), to be set to:
 - \times , if the module is not the last interlinked module (default position)
 - Rc, if the module is the last interlinked module.
- 2 Jumper used to select module number, to be set to:
 - MET1: 1st MET148-2 module, to measure temperatures T1 to T8 (default position)
 - MET2: 2nd MET148-2 module, to measure temperatures T9 to T16 (for Sepam series 40 and series 80 only).

Connection

⚠ DANGER

HAZARD OF ELECTRIC SHOCK, ELECTRIC ARC OR BURNS

- Only qualified personnel should install this equipment. Such work should be performed only after reading this entire set of instructions and checking the technical characteristics of the device.
 - NEVER work alone.
 - Check that the temperature sensors are isolated from dangerous voltages.
- Failure to follow these instructions will result in death or serious injury.**

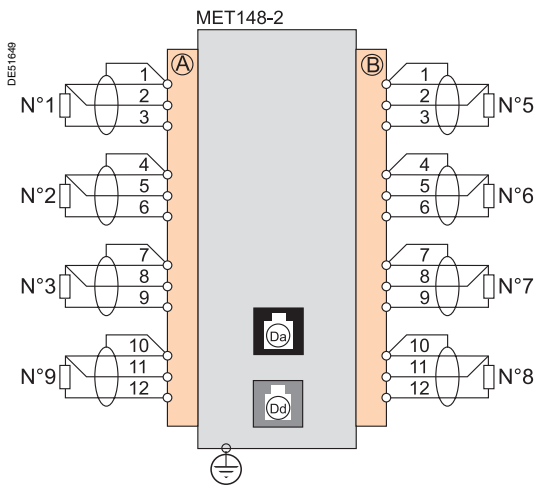

Connection of the earthing terminal

By tinned copper braid with cross-section $\geq 6 \text{ mm}^2$ (AWG 10) or cable with cross-section $\geq 2.5 \text{ mm}^2$ (AWG 12) and length $\leq 200 \text{ mm}$ (7.9 in), fitted with a 4 mm (0.16 in) ring lug. Check the tightness (maximum tightening torque 2.2 Nm or 19.5 lb-in).

Connection of RTDs to screw-type connectors

- 1 wire with cross-section 0.2 to 2.5 mm² (AWG 24-12)
 - or 2 wires with cross-section 0.2 to 1 mm² (AWG 24-18)
- Recommended cross-sections according to distance:
- Up to 100 m (330 ft) $\geq 1 \text{ mm}^2$ (AWG 18)
 - Up to 300 m (990 ft) $\geq 1.5 \text{ mm}^2$ (AWG 16)
 - Up to 1 km (0.62 mi) $\geq 2.5 \text{ mm}^2$ (AWG 12)
- Maximum distance between sensor and module: 1 km (0.62 mi)

Wiring precautions

- It is preferable to use shielded cables
- The use of unshielded cables can cause measurement errors which vary in degree according to the level of surrounding electromagnetic disturbance
- Only connect the shielding at the MET148-2 end, in the shortest manner possible, to the corresponding terminals of connectors (A) and (B)
 - Do not connect the shielding at the RTD end.

Accuracy derating according to wiring

The error Δt is proportional to the length of the cable and inversely proportional to the cable cross-section:

$$\Delta t(^{\circ}\text{C}) = 2 \times \frac{L(\text{km})}{S(\text{mm}^2)}$$

- $\pm 2.1^{\circ}\text{C}/\text{km}$ for 0.93 mm² cross-section (AWG 18)
- $\pm 1^{\circ}\text{C}/\text{km}$ for 1.92 mm² cross-section (AWG 14).

MSA141 Analog output module

1

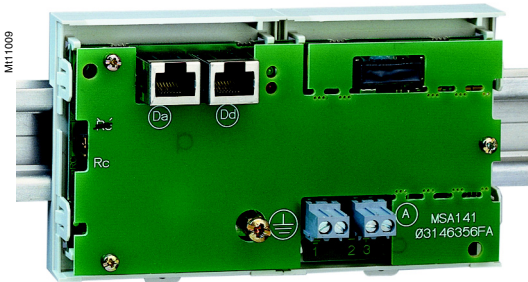

MSA141 analog output module.

Function

The MSA141 module converts one of the Sepam measurements into an analog signal:

- selection of the measurement to be converted by parameter setting
- 0-10 mA, 4-20 mA, 0-20 mA analog signal according to parameter setting
- scaling of the analog signal by setting minimum and maximum values of the converted measurement.

Example: the setting used to have phase current 1 as a 0-10 mA analog output with a dynamic range of 0 to 300 A is:

- minimum value = 0
- maximum value = 3000
- a single module for each Sepam base unit, to be connected by one of the CCA770 (0.6 m or 2 ft), CCA772 (2 m or 6.6 ft) or CCA774 cords (4 m or 13.1 ft).

The analog output may also be remotely managed via the communication network.

Characteristics

MSA141 module				
Weight	0.2 kg (0.441 lb)			
Assembly	On symmetrical DIN rail			
Operating temperature	-25°C to +70°C (-13°F to +158°F)			
Environmental characteristics	Same characteristics as Sepam base units			
Analog output				
Current	4-20 mA, 0-20 mA, 0-10 mA			
Scaling (no data input checking)	Minimum value			
	Maximum value			
Load impedance	< 600 Ω (wiring included)			
Accuracy	0.5 %			
Measurements available	Unit	Series 20	Series 40	Series 80
Phase and residual currents	0.1 A	■	■	■
Phase-to-neutral and phase-to-phase voltages	1 V	■	■	■
Frequency	0.01 Hz	■	■	■
Thermal capacity used	1 %	■	■	■
Temperatures	1°C (1°F)	■	■	■
Active power	0.1 kW		■	■
Reactive power	0.1 kVAR		■	■
Apparent power	0.1 kVA		■	■
Power factor	0.01			■
Remote setting via communication link		■	■	■

MSA141 Analog output module

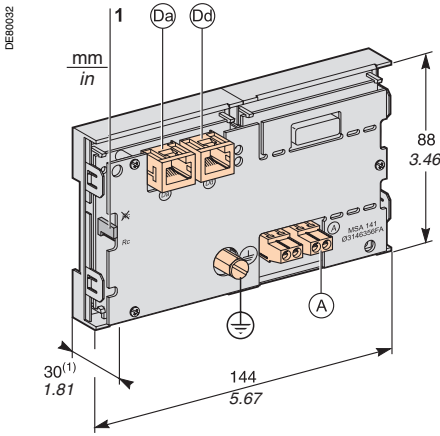

(1) 70 mm (2.8 in) with CCA77x cord connected.

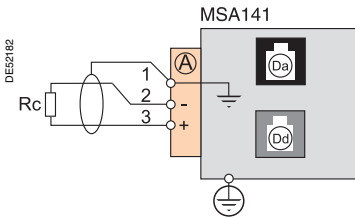

Description and dimensions

- (A) Terminal block for analog output.
- (Da) RJ45 connector to connect the module to the base unit with a CCA77x cord.
- (Dd) RJ45 connector to link up the next remote module with a CCA77x cord (according to application).
- (⊕) Grounding/earthing terminal.

- 1 Jumper for impedance matching with load resistor (Rc), to be set to:
 - Rc, if the module is not the last interlinked module (default position)
 - Rc, if the module is the last interlinked module.

Connection

Earthing terminal connection

By tinned copper braid with cross-section $\geq 6 \text{ mm}^2$ (AWG 10) or cable with cross-section $\geq 2.5 \text{ mm}^2$ (AWG 12) and length $\leq 200 \text{ mm}$ (7.9 in), equipped with a 4 mm (0.16 in) ring lug.

Check the tightness (maximum tightening torque 2.2 Nm (19.5 lb-in)).

Connection of analog output to screw-type connector

- 1 wire with cross-section 0.2 to 2.5 mm² (AWG 24-12)
- or 2 wires with cross-section 0.2 to 1 mm² (AWG 24-16).

Wiring precautions

- it is preferable to use shielded cables
- use tinned copper braid to connect the shielding at least at the MSA141 end.

DSM303 Remote advanced UMI module

1



DSM303 remote advanced UMI module.

Function

When associated with a Sepam that does not have its own advanced user-machine interface, the DSM303 offers all the functions available on a Sepam integrated advanced UMI.

It can be installed on the front panel of the cubicle in the most suitable operating location:

- Reduced depth < 30 mm (1.2 in)
- A single module for each Sepam, to be connected by one of the CCA772 (2 m or 6.6 ft) or CCA774 (4 m or 13.1 ft) cords.

The module cannot be connected to Sepam units with integrated advanced UMIs.

Characteristics

DSM303 module	
Weight	0.3 kg (0.661 lb)
Assembly	Flush-mounted
Operating temperature	-25°C to +70°C (-13°F to +158°F)
Environmental characteristics	Same characteristics as Sepam base units

Description and dimensions

The module is simply flush-mounted and secured by its clips. No additional screw-type fastening is required.

Front view

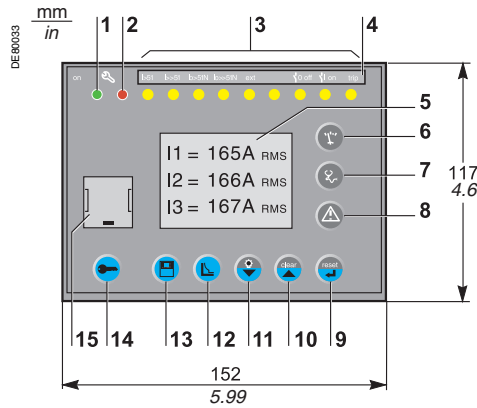

Side view

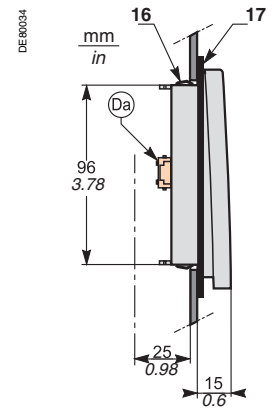

- 1 Green LED: Sepam on
 - 2 Red LED:
 - steadily on: module unavailable
 - flashing: Sepam link unavailable
 - 3 9 yellow LEDs
 - 4 Label identifying the LEDs
 - 5 Graphic LCD screen
 - 6 Display of measurements
 - 7 Display of switchgear, network and machine diagnosis data
 - 8 Display of alarm messages
 - 9 Sepam reset (or confirm data entry)
 - 10 Alarm acknowledgment and clearing (or move cursor up)
 - 11 LED test (or move cursor down)
 - 12 Access to protection settings
 - 13 Access to Sepam parameters
 - 14 Entry of 2 passwords
 - 15 PC connection port
 - 16 Mounting clip
 - 17 Gasket to ensure NEMA 12 tightness
(gasket supplied with the DSM303 module, to be installed if necessary)
- (Da) RJ45 lateral output connector to connect the module to the base unit with a CCA77x cord.

⚠ CAUTION

HAZARD OF CUTS
Trim the edges of the cut-out plates to remove any jagged edges.

Failure to follow this instruction can cause serious injury.

Cut-out for flush-mounting (mounting plate thickness < 3 mm or 0.12 in)

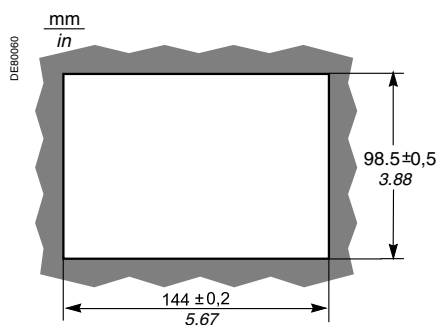

Connection

(Da) RJ45 socket to connector the module to the base unit with a CCA77x cord. The DSM303 module is always the last interlinked remote module and it systematically ensures impedance matching by load resistor (Rc).

DSM303

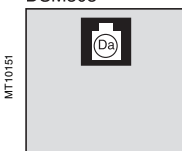

MCS025 Synchro-check module

1

PE50086



MCS025 synchro-check module.

Function

The MCS025 module checks the voltages upstream and downstream of a circuit breaker to ensure safe closing (ANSI 25).

It checks the differences in amplitude, frequency and phase between the two measured voltages, taking into account dead line/busbar conditions.

Three relay outputs may be used to send the close enable to several Sepam series 80 units.

The circuit-breaker control function of each Sepam series 80 unit will take this close enable into account.

The settings for the synchro-check function and the measurements carried out by the module may be accessed by the SFT2841 setting and operating software, similar to the other settings and measurements for the Sepam series 80.

The MCS025 module is supplied ready for operation with:

- the CCA620 connector for connection of the relay outputs and the power supply
- the CCT640 connector for voltage connection
- the CCA785 cord for connection between the module and the Sepam series 80 base unit.

Characteristics

MCS025 module					
Weight	1.35 kg (2.98 lb)				
Assembly	With the AMT840 accessory				
Operating temperature	-25°C to +70°C (-13°F to +158°F)				
Environmental characteristics	Same characteristics as Sepam base units				
Voltage inputs					
Input impedance	> 100 kΩ				
Consumption	< 0.015 VA (VT 100 V)				
Continuous thermal withstand	240 V				
1-second overload	480 V				
Relay outputs					
Relay outputs O1 and O2					
Voltage	DC	24/48 V DC	127 V DC	220 V DC	
	AC (47.5 to 63 Hz)				100 to 240 V AC
Continuous current		8 A	8 A	8 A	8 A
Breaking capacity	Resistive load	8 A / 4 A	0.7 A	0.3 A	
	Load L/R < 20 ms	6 A / 2 A	0.5 A	0.2 A	
	Load L/R < 40 ms	4 A / 1 A	0.2 A	0.1 A	
	Resistive load				8 A
	Load p.f. > 0.3				5 A
Making capacity	< 15 ms for 200 ms				
Isolation of outputs from other isolated groups	Enhanced				
Relay outputs O3 and O4 (O4 not used)					
Voltage	DC	24 / 48 V DC	127 V DC	220 V DC	
	AC (47.5 to 63 Hz)				100 to 240 V AC
Continuous current		2 A	2 A	2 A	2 A
Breaking capacity	Load L/R < 20 ms	2 A / 1 A	0.5 A	0.15 A	
	Load p.f. > 0.3				5 A
Isolation of outputs from other isolated groups	Enhanced				
Power supply					
Voltage	24 to 250 V DC, -20 % / +10 %		110 to 240 V AC, -20 % / +10 % 47.5 to 63 Hz		
Maximum consumption	6 W		9 VA		
Inrush current	< 10 A for 10 ms		< 15 A for one half period		
Acceptable momentary outages	10 ms		10 ms		

Description

- 1 MCS025 module
- (A) CCA620 20-pin connector for:
 - auxiliary power supply
 - 4 relay outputs:
 - O1, O2, O3: close enable.
 - O4: not used
- (B) CCT640 connector (phase-to-neutral or phase-to-phase) for the two input voltages to be synchronized
- (C) RJ45 connector, not used
- (D) RJ45 connector for module connection to the Sepam series 80 base unit, either directly or via another remote module.
- 2 Two mounting clips
- 3 Two holding pins for the flush-mount position
- 4 CCA785 connection cord

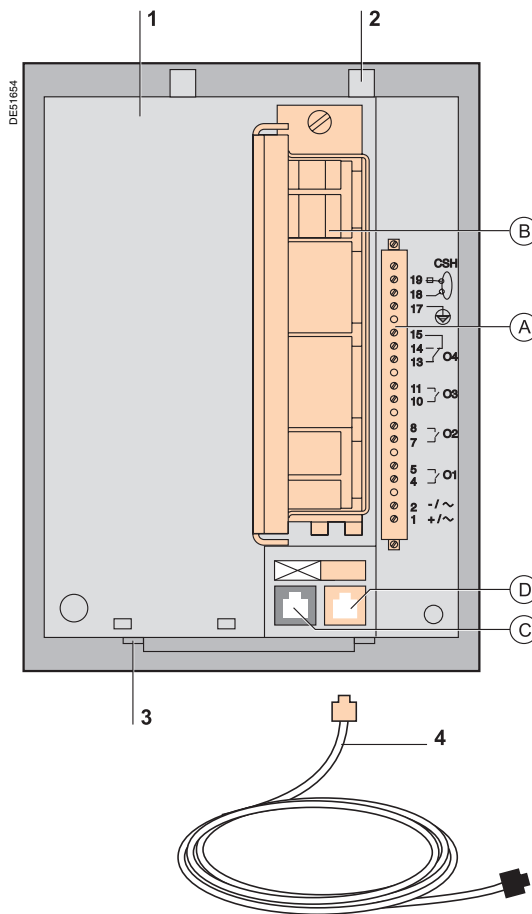

MCS025 Synchro-check module

1

Dimensions

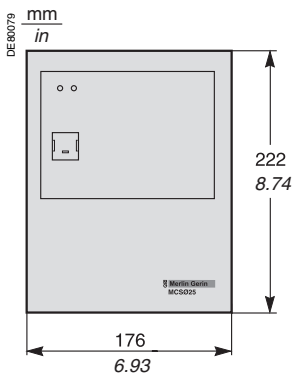

MCS025.

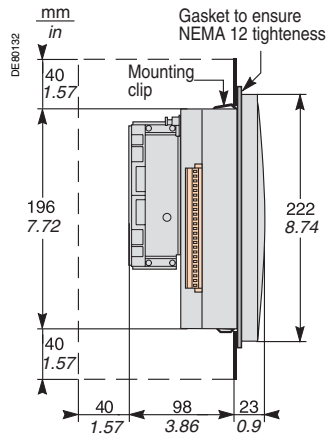

Assembly with AMT840 mounting plate

The MCS025 module should be mounted at the back of the compartment using the AMT840 mounting plate.

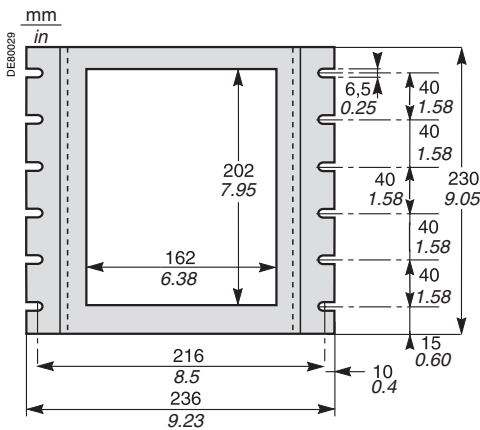

AMT840 mounting plate.

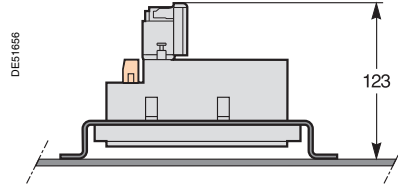

Connection characteristics

Connector	Type	Reference	Wiring
(A)	Screw-type	CCA620	<ul style="list-style-type: none"> ■ wiring with no fittings: <ul style="list-style-type: none"> □ 1 wire with maximum cross-section 0.2 to 2.5 mm² (> AWG 24-12) or 2 wires with cross-section 0.2 to 1 mm² (>AWG 24-16) □ stripped length: 8 to 10 mm (0.31 to 0.39 in) ■ wiring with fittings: <ul style="list-style-type: none"> □ recommended wiring with Telemecanique fittings: <ul style="list-style-type: none"> - DZ5CE015D for 1 wire 1.5 mm² (AWG 16) - DZ5CE025D for 1 wire 2.5 mm² (AWG 12) - AZ5DE010D for 2 x 1 mm² wires (AWG 18) □ tube length: 8.2 mm (0.32 in) □ stripped length: 8 mm (0.32 in)
(B)	Screw-type	CCT640	VT wiring: same as wiring of the CCA620 Earthing connection: by 4 mm (0.15 mm) ring lug
(D)	Orange RJ45 connector		CCA785, special prefabricated cord supplied with the MCS025 module: <ul style="list-style-type: none"> ■ orange RJ45 connector for connection to port (D) on the MCS025 module ■ black RJ45 connector for connection to the Sepam series 80 base unit, either directly or via another remote module.

Connection diagram

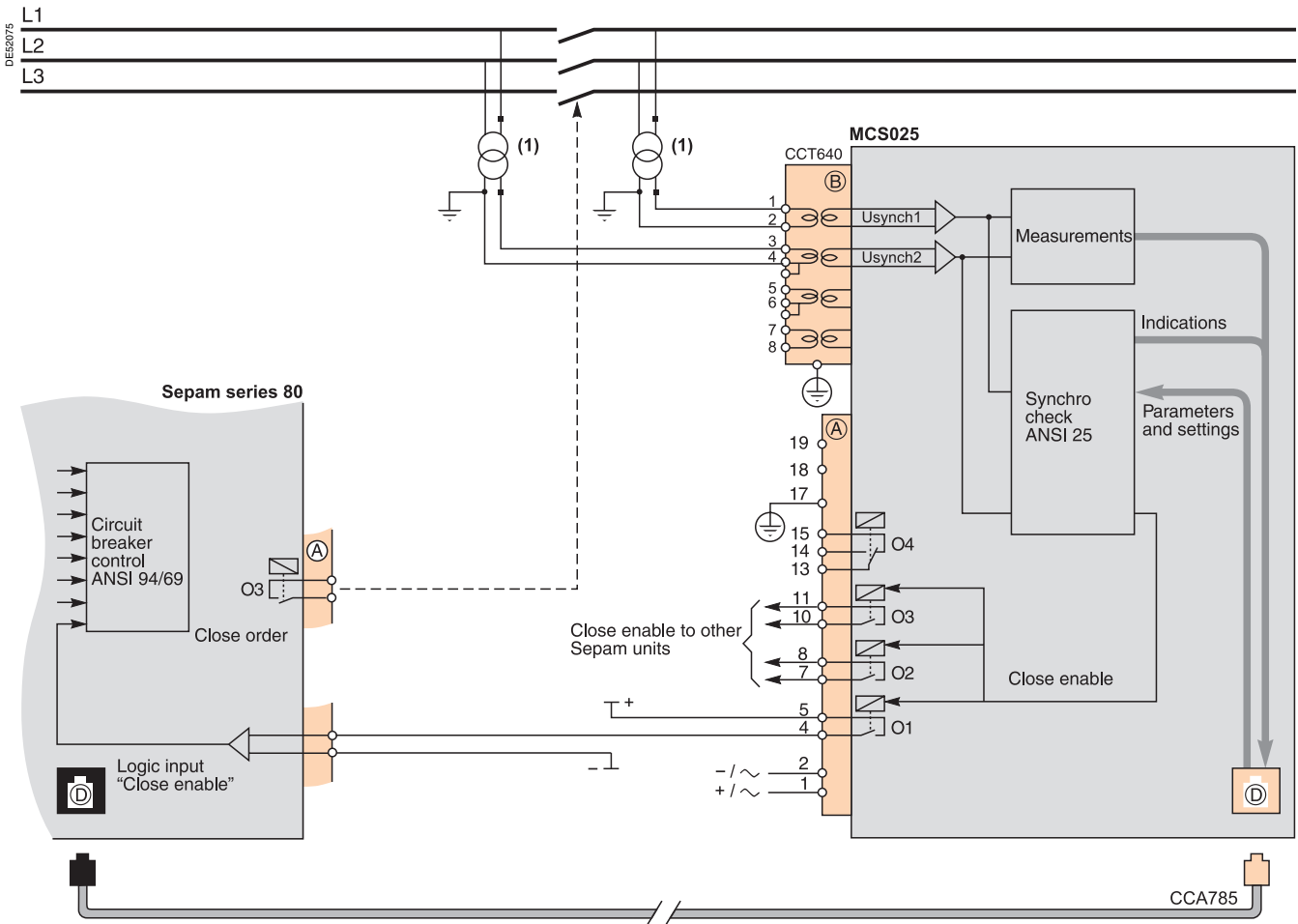

(1) Phase-to-phase or phase-to-neutral connection.

⚠ CAUTION

HAZARD OF NON-OPERATION

The MCS025 module must ALWAYS be connected with the special CCA785 cord, supplied with the module and equipped with an orange RJ45 plug and a black RJ45 plug.

Failure to follow this instruction can cause equipment damage.

⚠ DANGER

HAZARD OF ELECTRIC SHOCK, ELECTRIC ARC OR BURNS

- Only qualified personnel should install this equipment. Such work should be performed only after reading this entire set of instructions and checking the technical characteristics of the device.
- NEVER work alone.
- Check that the temperature sensors are isolated from dangerous voltages.
- Always use a properly rated voltage sensing device to confirm that all power is off.
- Start by connecting the device to the protective earth and to the functional earth.
- Terminal 17 (PE) on connector (A) of the MCS025 module and the functional earth terminal on the Sepam series 80 unit must be connected locally to the cubicle grounding circuit. The two connection points should be as close as possible to one another.
- Screw tight all terminals, even those not in use.

Failure to follow these instructions will result in death or serious injury.

There are 2 types of Sepam communication accessory:

- Communication interfaces, which are essential for connecting Sepam to the communication network
- Converters and other accessories, as options, which are used for complete implementation of the communication network.

Communication-interface selection guide

	ACE949-2	ACE959	ACE937	ACE969TP-2	ACE969FO-2	ACE850TP	ACE850FO		
Type of network									
	S-LAN or E-LAN (1)	S-LAN or E-LAN (1)	S-LAN or E-LAN (1)	S-LAN	E-LAN	S-LAN	E-LAN	S-LAN and E-LAN	S-LAN and E-LAN
Protocol									
Modbus RTU	■	■	■	■ (3)	■	■ (3)	■	■	■
DNP3				■ (3)		■ (3)			
IEC 60870-5-103				■ (3)		■ (3)			
Modbus TCP/IP								■ (3)	■ (3)
IEC 61850								■ (3)	■ (3)
Physical interface									
RS 485	2-wire	■		■	■		■		
	4-wire		■						
Fiber optic ST	Star		■			■			
	Ring					■ (2)			
10/100 base T	1 port							■	
100 base Fx	1 port								■
Power supply									
DC	Supplied by Sepam	Supplied by Sepam	Supplied by Sepam	24 to 250 V	24 to 250 V	24 to 250 V	24 to 250 V	24 to 250 V	24 to 250 V
AC				110 to 240 V	110 to 240 V	110 to 240 V	110 to 240 V	110 to 240 V	110 to 240 V
See details on page	page 56	page 57	page 58	page 59	page 59	(4)	(4)	(4)	(4)

(1) Only one connection possible, S-LAN or E-LAN.

(2) Except with the Modbus RTU protocol.

(3) Not supported simultaneously (1 protocol per application).

(4) Available in the near future for Sepam series 40 and Sepam series 80.

Converter selection guide

	ACE909-2	ACE919CA	ACE919CC	EGX100	EGX400	ECI850
To supervisor						
Physical interface	1 RS 232 port	1 port 2-wire RS 485	1 port 2-wire RS 485	1 Ethernet port 10/100 base T	2 Ethernet ports 10/100 base T 100 base F	1 Ethernet port 10/100 base T
Modbus RTU	■ (1)	■ (1)	■ (1)			
IEC 60870-5-103	■ (1)	■ (1)	■ (1)			
DNP3	■ (1)	■ (1)	■ (1)			
Modbus TCP/IP				■	■	
IEC 61850						■
To Sepam						
Physical interface	1 port 2-wire RS 485	1 port 2-wire RS 485	1 port 2-wire RS 485	1 port RS 485 2-wire or 4-wire	2 ports RS 485 2-wire or 4-wire	1 port RS 485 2-wire or 4-wire
RS 485 distributed power supply	■	■	■			
Modbus RTU	■ (1)	■ (1)	■ (1)	■	■	■
IEC 60870-5-103	■ (1)	■ (1)	■ (1)			
DNP3	■ (1)	■ (1)	■ (1)			
Power supply						
DC			24 to 48 V	24 V	24 V	24 V
AC	110 to 220 V	110 to 220 V			100 to 240 V with adapter	
See details on page	page 64	page 66	page 66	See EGX100 manual	See EGX400 manual	page 68

(1) The supervisor protocol is the same as for Sepam.

Note: All these interfaces support the E-LAN protocol.

CCA612 connection cord

For connection to Sepam

Cord used to connect a communication interface to a Sepam base unit:

- Length = 3 m (9.8 ft)
- Fitted with 2 green RJ45 plugs.

Sepam series 20 and Sepam series 40

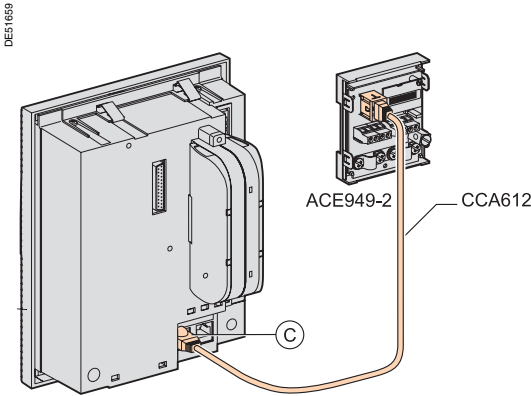

Sepam series 20 and Sepam series 40: 1 communication port.

Sepam series 80

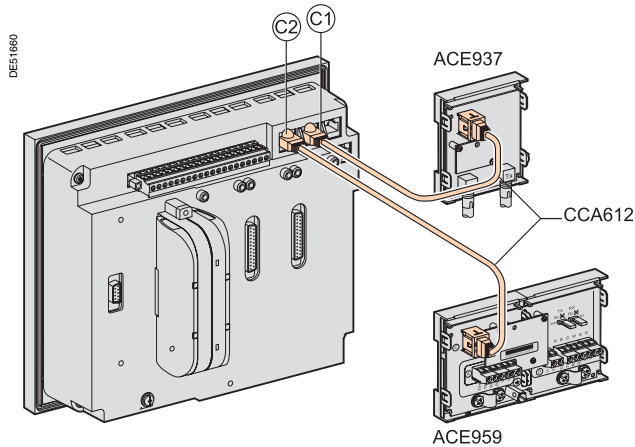

Sepam series 80: 2 communication ports.

RS 485 network cable

RS 485 network cable	2-wire	4-wire
RS 485 medium	1 shielded twisted pair	2 shielded twisted pairs
Distributed power supply	1 shielded twisted pair	1 shielded twisted pair
Shielding	Tinned copper braid, coverage > 65 %	
Characteristic impedance	120 Ω	
Gauge	AWG 24	
Resistance per unit length	< 100 Ω/km (62.1 Ω/mi)	
Capacitance between conductors	< 60 pF/m (18.3 pF/ft)	
Capacitance between conductor and shielding	< 100 pF/m (30.5 pF/ft)	
Maximum length	1300 m (4270 ft)	

Fiber optic

Fiber type	Multimode glass			
Wavelength	820 nm (infra-red)			
Type of connector	ST (BFOC bayonet fiber optic connector)			
Fiber optic diameter (μm)	Numerical aperture (NA)	Maximum attenuation (dBm/km)	Minimum optical power available (dBm)	Maximum length of fiber (m)
50/125	0.2	2.7	5.6	700 (2300 ft)
62.5/125	0.275	3.2	9.4	1800 (5900 ft)
100/140	0.3	4	14.9	2800 (9200 ft)
200 (HCS)	0.37	6	19.2	2600 (8500 ft)

ACE949-2 2-wire RS 485 network interface

1

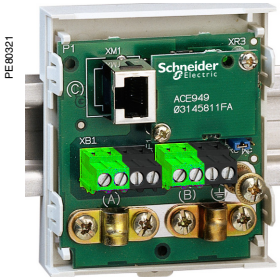

ACE949-2 2-wire RS 485 network connection interface.

Function

The ACE949-2 interface performs 2 functions:

- Electrical interface between Sepam and a 2-wire RS 485 communication network
- Main network cable branching box for the connection of a Sepam with a CCA612 cord.

Characteristics

ACE949-2 module	
Weight	0.1 kg (0.22 lb)
Assembly	On symmetrical DIN rail
Operating temperature	-25°C to +70°C (-13°F to +158°F)
Environmental characteristics	Same characteristics as Sepam base units
2-wire RS 485 electrical interface	
Standard	EIA 2-wire RS 485 differential
Distributed power supply	External, 12 V DC or 24 V DC ±10%
Power consumption	16 mA in receiving mode 40 mA maximum in sending mode

Maximum length of 2-wire RS 485 network with standard cable		
Number of Sepam units	Maximum length with 12 V DC power supply	Maximum length with 24 V DC power supply
5	320 m (1000 ft)	1000 m (3300 ft)
10	180 m (590 ft)	750 m (2500 ft)
20	160 m (520 ft)	450 m (1500 ft)
25	125 m (410 ft)	375 m (1200 ft)

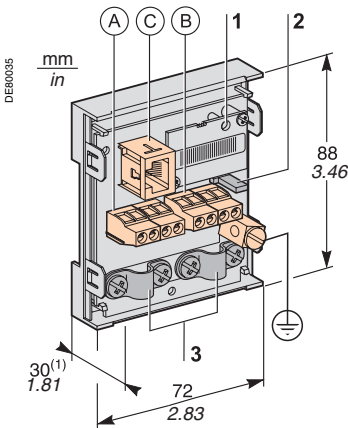

(1) 70 mm (2.8 in) with CCA612 cord connected.

Description and dimensions

- (A) and (B) Terminal blocks for network cable
- (C) RJ45 socket to connect the interface to the base unit with a CCA612 cord
- (t) Grounding/earthing terminal

- 1 Link activity LED, flashes when communication is active (sending or receiving in progress).
- 2 Jumper for RS 485 network line-end impedance matching with load resistor ($R_c = 150 \Omega$), to be set to:
 - X , if the module is not at one end of the network (default position)
 - R_c , if the module is at one end of the network.
- 3 Network cable clamps (inner diameter of clamp = 6 mm or 0.24 in).

Connection

- Connection of network cable to screw-type terminal blocks (A) and (B)
- Connection of the earthing terminal by tinned copper braid with cross-section $\geq 6 \text{ mm}^2$ (AWG 10) or cable with cross-section $\geq 2.5 \text{ mm}^2$ (AWG 12) and length $\leq 200 \text{ mm}$ (7.9 in), fitted with a 4 mm (0.16 in) ring lug. Check the tightness (maximum tightening torque 2.2 Nm or 19.5 lb-in).
- The interfaces are fitted with clamps to hold the network cable and recover shielding at the incoming and outgoing points of the network cable:
 - the network cable must be stripped
 - the cable shielding braid must be around and in contact with the clamp
- The interface is to be connected to connector (C) on the base unit using a CCA612 cord (length = 3 m or 9.8 ft, green fittings)
- The interfaces are to be supplied with 12 V DC or 24 V DC.

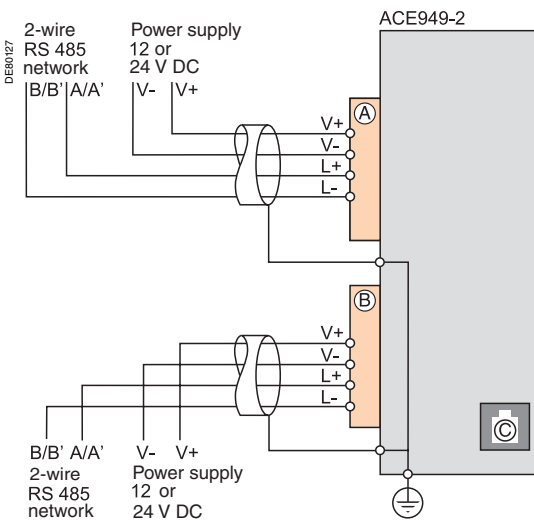

ACE959 4-wire RS 485 network interface

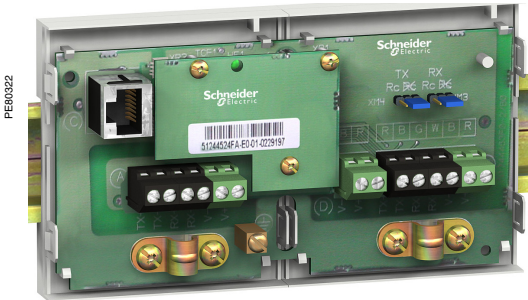

ACE959 4-wire RS 485 network connection interface.

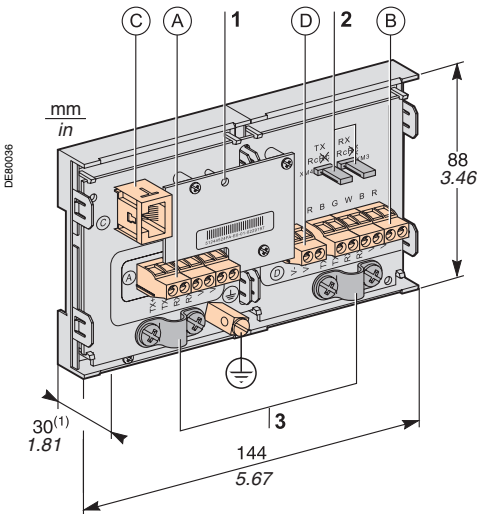

(1) 70 mm (2.8 in) with CCA612 cord connected.

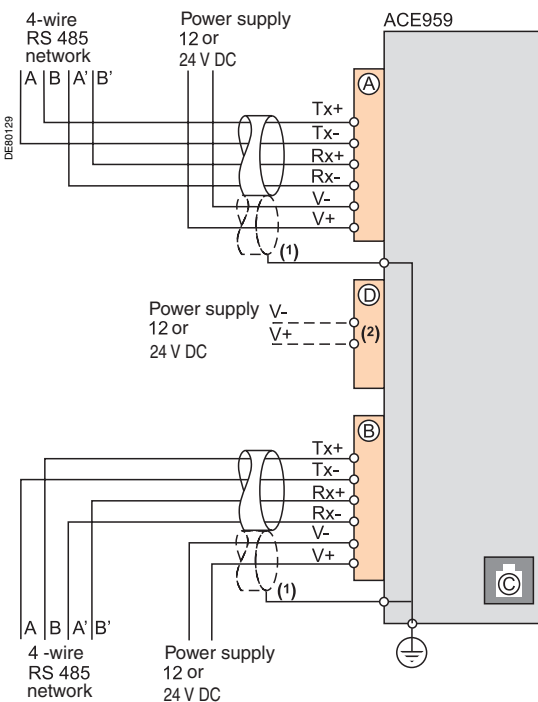

(1) Distributed power supply with separate wiring or included in the shielded cable (3 pairs).
(2) Terminal block for connection of the distributed power supply module.

Function

The ACE959 interface performs 2 functions:

- Electrical interface between Sepam and a 4-wire RS 485 communication network
- Main network cable branching box for the connection of a Sepam with a CCA612 cord.

Characteristics

ACE959 module

Weight	0.2 kg (0.441 lb)
Assembly	On symmetrical DIN rail
Operating temperature	-25°C to +70°C (-13°F to +158°F)
Environmental characteristics	Same characteristics as Sepam base units

4-wire RS 485 electrical interface

Standard	EIA 4-wire RS 485 differential
Distributed power supply	External, 12 V DC or 24 V DC ±10%
Power consumption	16 mA in receiving mode 40 mA maximum in sending mode

Maximum length of 4-wire RS 485 network with standard cable

Number of Sepam units	Maximum length with 12 V DC power supply	Maximum length with 24 V DC power supply
5	320 m (1000 ft)	1000 m (3300 ft)
10	180 m (590 ft)	750 m (2500 ft)
20	160 m (520 ft)	450 m (1500 ft)
25	125 m (410 ft)	375 m (1200 ft)

Description and dimensions

- (A) and (B) Terminal blocks for network cable
- (C) RJ45 socket to connect the interface to the base unit with a CCA612 cord
- (D) Terminal block for a separate auxiliary power supply (12 V DC or 24 V DC)
- (t) Grounding/earthing terminal

- 1 Link activity LED, flashes when communication is active (sending or receiving in progress).
- 2 Jumper for 4-wire RS 485 network line-end impedance matching with load resistor ($R_c = 150 \Omega$), to be set to:
 - R_c , if the module is not at one end of the network (default position)
 - R_c , if the module is at one end of the network.
- 3 Network cable clamps (inner diameter of clamp = 6 mm or 0.24 in).

Connection

- Connection of network cable to screw-type terminal blocks (A) and (B)
- Connection of the earthing terminal by tinned copper braid with cross-section $\geq 6 \text{ mm}^2$ (AWG 10) or cable with cross-section $\geq 2.5 \text{ mm}^2$ (AWG 12) and length $\leq 200 \text{ mm}$ (7.9 in), fitted with a 4 mm (0.16 in) ring lug. Check the tightness (maximum tightening torque 2.2 Nm or 19.5 lb-in).
- The interfaces are fitted with clamps to hold the network cable and recover shielding at the incoming and outgoing points of the network cable:
 - the network cable must be stripped
 - the cable shielding braid must be around and in contact with the clamp
- The interface is to be connected to connector (C) on the base unit using a CCA612 cord (length = 3 m or 9.8 ft, green fittings)
- The interfaces are to be supplied with 12 V DC or 24 V DC
- The ACE959 can be connected to a separate distributed power supply (not included in shielded cable). Terminal block (D) is used to connect the distributed power supply module.

1

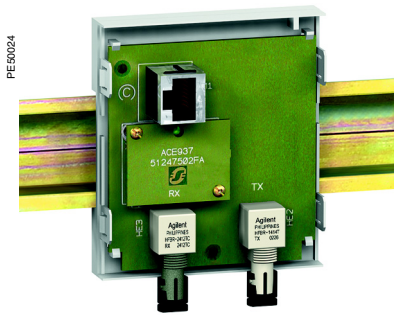

ACE937 fiber optic connection interface.

⚠ CAUTION

HAZARD OF BLINDING
Never look directly into the end of the fiber optic.
Failure to follow this instruction can cause serious injury.

Function

The ACE937 interface is used to connect Sepam to a fiber optic communication star system. This remote module is connected to the Sepam base unit by a CCA612 cord.

Characteristics

ACE937 module				
Weight	0.1 kg (0.22 lb)			
Assembly	On symmetrical DIN rail			
Power supply	Supplied by Sepam			
Operating temperature	-25°C to +70°C (-13°F to +158°F)			
Environmental characteristics	Same characteristics as Sepam base units			
Fiber optic interface				
Fiber type	Graded-index multimode silica			
Wavelength	820 nm (invisible infra-red)			
Type of connector	ST (BFOC bayonet fiber optic connector)			
Fiber optic diameter (µm)	Numerical aperture (NA)	Maximum attenuation (dBm/km)	Minimum optical power available (dBm)	Maximum fiber length
50/125	0.2	2.7	5.6	700 m (2300 ft)
62.5/125	0.275	3.2	9.4	1800 m (5900 ft)
100/140	0.3	4	14.9	2800 m (9200 ft)
200 (HCS)	0.37	6	19.2	2600 m (8500 ft)

- Maximum length calculated with:
- Minimum optical power available
 - Maximum fiber attenuation
 - Losses in 2 ST connectors: 0.6 dBm
 - Optical power margin: 3 dBm (according to IEC 60870 standard).

Example for a 62.5/125 µm fiber
 $L_{max} = (9.4 - 3 - 0.6)/3.2 = 1.8 \text{ km (1.12 mi)}$

Description and dimensions

Ⓒ RJ45 socket to connect the interface to the base unit with a CCA612 cord.

- 1 Link activity LED, flashes when communication is active (sending or receiving in progress).
- 2 Rx, female ST type connector (Sepam receiving).
- 3 Tx, female ST type connector (Sepam sending).

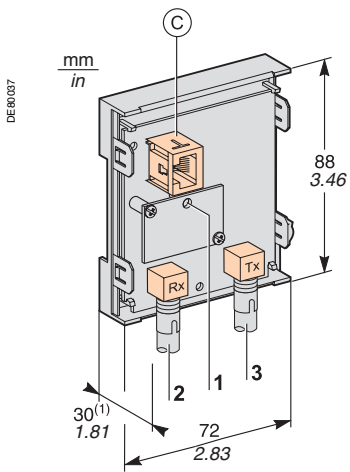

(1) 70 mm (2.8 in) with CCA612 cord connected.

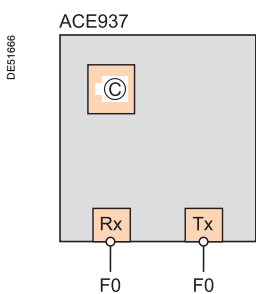

Connection

- The sending and receiving fiber optic fibers must be equipped with male ST type connectors
 - Fiber optics screw-locked to Rx and Tx connectors.
- The interface is to be connected to connector Ⓒ on the base unit using a CCA612 cord (length = 3 m or 9.8 ft, green fittings).

PE1033454

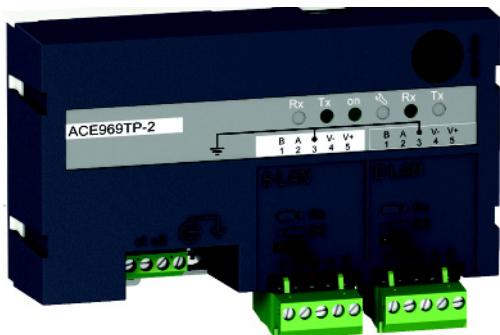

ACE969TP-2 communication interface.

PE1033453

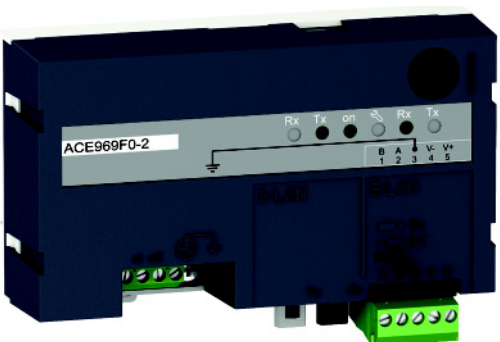

ACE969FO-2 communication interface.

Function

The ACE969 multi-protocol communication interfaces are for Sepam series 20, Sepam series 40 and Sepam series 80.

They have two communication ports to connect a Sepam to two independent communication networks:

- The S-LAN (Supervisory Local Area Network) port is used to connect Sepam to a communication network dedicated to supervision, using one of the three following protocols:

- IEC 60870-5-103
- DNP3
- Modbus RTU.

The communication protocol is selected at the time of Sepam parameter setting.

- The E-LAN (Engineering Local Area Network) port, reserved for Sepam remote parameter setting and operation using the SFT2841 software.

There are two versions of the ACE969 interfaces, which are identical except for the S-LAN port:

- ACE969TP-2 (Twisted Pair), for connection to an S-LAN network using a 2-wire RS 485 serial link
- ACE969FO-2 (Fiber Optic), for connection to an S-LAN network using a fiber-optic connection (star or ring).

The E-LAN port is always a 2-wire RS 485 type port.

Compatible Sepam

The ACE969TP-2 et ACE969FO-2 multi-protocol interfaces are compatible with the following Sepam:

- Sepam series 20 version \geq V0526
- Sepam series 40 version \geq V3.00
- Sepam series 80 base version and application version \geq V3.00.

ACE969TP-2 and ACE969FO-2 Multi-protocol interfaces

1

Characteristics

ACE969TP-2 and ACE969FO-2 module

Technical characteristics

Weight	0.285 kg (0.628 lb)	
Assembly	On symmetrical DIN rail	
Operating temperature	-25°C to +70°C (-13°F to +158°F)	
Environmental characteristics	Same characteristics as Sepam base units	

Power supply

Voltage	24 to 250 V DC	110 to 240 V AC
Range	-20%/+10%	-20%/+10%
Maximum consumption	2 W	3 VA
Inrush current	< 10 A 100 μs	
Acceptable ripple content	12%	
Acceptable momentary outages	20 ms	

2-wire RS 485 communication ports

Electrical interface

Standard	EIA 2-wire RS 485 differential
Distributed power supply	ACE969-2 not required (built-in)

Fiber optic communication port

Fiber optic interface

Fiber type	Graded-index multimode silica
Wavelength	820 nm (invisible infra-red)
Type of connector	ST (BFOC bayonet fiber optic connector)

Maximum length of fiber optic network

Fiber diameter (μm)	Numerical aperture (NA)	Attenuation (dBm/km)	Minimum optical power available (dBm)	Maximum fiber length
50/125	0.2	2.7	5.6	700 m (2300 ft)
62.5/125	0.275	3.2	9.4	1800 m (5900 ft)
100/140	0.3	4	14.9	2800 m (9200 ft)
200 (HCS)	0.37	6	19.2	2600 m (8500 ft)

Maximum length calculated with:

- Minimum optical power available
- Maximum fiber attenuation
- Losses in 2 ST connectors: 0.6 dBm
- Optical power margin: 3 dBm (according to IEC 60870 standard).

Example for a 62.5/125 μm fiber

$$L_{max} = (9.4 - 3 - 0.6) / 3.2 = 1.8 \text{ km (1.12 mi)}$$

Dimensions

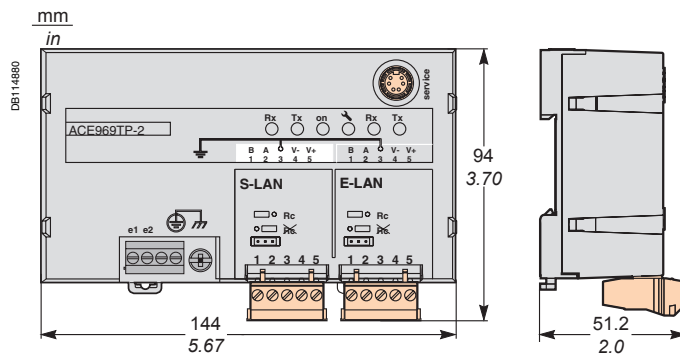

ACE969TP-2 and ACE969FO-2 Multi-protocol interfaces Description

ACE969-2 communication interfaces

- 1 Grounding/earthing terminal using supplied braid
- 2 Power-supply terminal block
- 3 RJ45 socket to connect the interface to the base unit with a CCA612 cord
- 4 Green LED: ACE969-2 energized
- 5 Red LED: ACE969-2 interface status
 - LED off = ACE969-2 set up and communication operational
 - LED flashing = ACE969-2 not set up or setup incorrect
 - LED remains on = ACE969-2 has faulted
- 6 Service connector: reserved for software upgrades
- 7 E-LAN 2-wire RS 485 communication port (ACE969TP-2 and ACE969FO-2)
- 8 S-LAN 2-wire RS 485 communication port (ACE969TP-2)
- 9 S-LAN fiber-optic communication port (ACE969FO-2).

ACE969TP-2

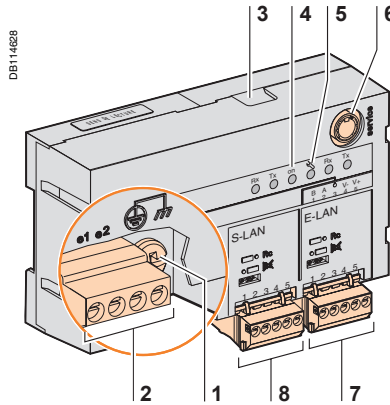

ACE969FO-2

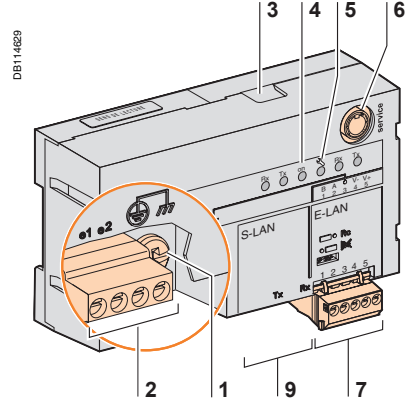

2-wire RS 485 communication ports

- 1 Draw-out terminal block, with two rows of connections to the RS 485 2-wire network:
 - 2 black terminals: connection of RS 485 twisted-pair (2 wires)
 - 2 green terminals: connection of twisted pair for distributed power supply
- 2 Indication LEDs:
 - flashing Tx LED: Sepam sending
 - flashing Rx LED: Sepam receiving
- 3 Jumper for RS 485 network line-end impedance matching with load resistor ($R_c = 150 \Omega$), to be set to:
 - \times , if the interface is not at the line end (default position)
 - R_c , if the interface is at the line end.

S-LAN port (ACE969TP-2)

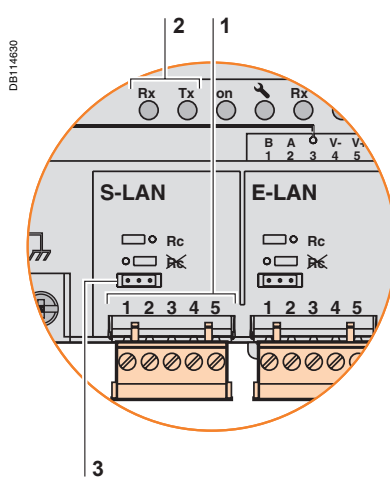

E-LAN port (ACE969TP-2 or ACE969FO-2)

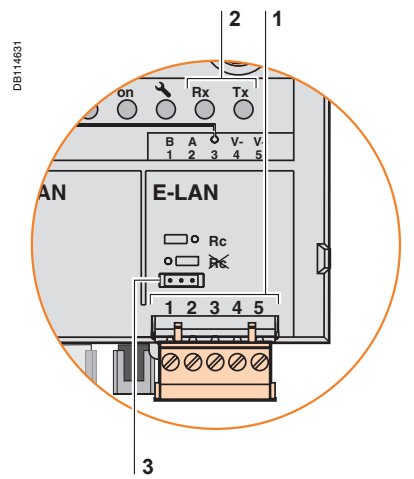

Fiber optic communication port

- 1 Indication LEDs:
 - flashing Tx LED: Sepam sending
 - flashing Rx LED: Sepam receiving
- 2 Rx, female ST-type connector (Sepam receiving)
- 3 Tx, female ST-type connector (Sepam sending).

S-LAN port (ACE969FO-2)

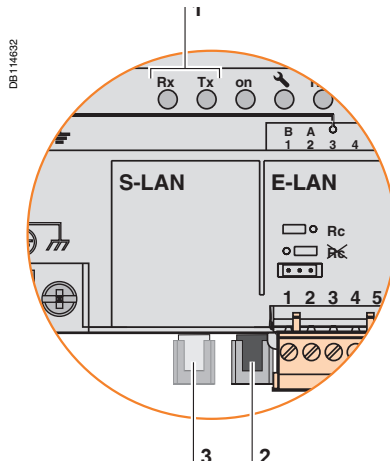

ACE969TP-2 and ACE969FO-2 Multi-protocol interfaces Connection

1

Power supply and Sepam

- The ACE969-2 interface connects to connector C on the Sepam base unit using a CCA612 cord (length = 3 m or 9.84 ft, white RJ45 fittings)
- The ACE969-2 interface must be supplied with 24 to 250 V DC or 110 to 240 V AC.

⚠ DANGER

HAZARD OF ELECTRIC SHOCK, ELECTRIC ARC OR BURNS

- Only qualified personnel should install this equipment. Such work should be performed only after reading this entire set of instructions and checking the technical characteristics of the device.
- NEVER work alone.
- Turn off all power supplying this equipment before working on or inside it. Consider all sources of power, including the possibility of backfeeding.
- Always use a properly rated voltage sensing device to confirm that all power is off.
- Start by connecting the device to the protective earth and to the functional earth.
- Screw tight all terminals, even those not in use.

Failure to follow these instructions will result in death or serious injury.

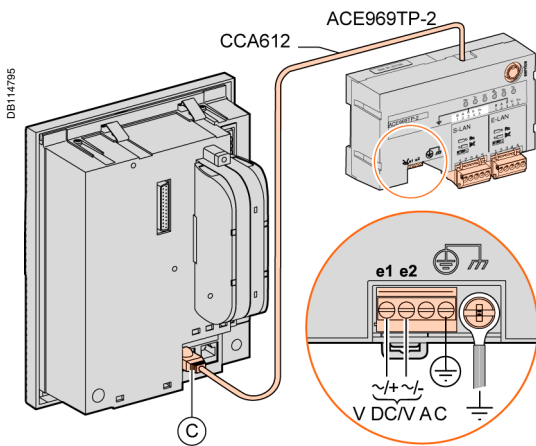

Terminals	Type	Wiring
e1-e2 - supply	Screw terminals	<ul style="list-style-type: none"> ■ Wiring with no fittings: <ul style="list-style-type: none"> □ 1 wire with maximum cross-section 0.2 to 2.5 mm² (≥ AWG 24-12) or 2 wires with maximum cross-section 0.2 to 1 mm² (≥ AWG 24-18) □ stripped length: 8 to 10 mm (0.31 to 0.39 in) ■ Wiring with fittings: <ul style="list-style-type: none"> □ recommended wiring with Telemecanique fitting: <ul style="list-style-type: none"> - DZ5CE015D for 1 wire 1.5 mm² (AWG 16) - DZ5CE025D for 1 wire 2.5 mm² (AWG 12) - AZ5DE010D for 2 wires 1 mm² (AWG 18) □ tube length: 8.2 mm (0.32 in) □ stripped length: 8 mm (0.31 in).
Protective earth	Screw terminal	1 green/yellow wire, max. length 3 m (9.8 ft) and max. cross-section 2.5 mm ² (AWG 12)
Functional earth	4 mm (0.16 in) ring lug	Earthing braid, supplied for connection to cubicle grounding

ACE969TP and ACE969FO Multi-protocol interfaces Connection

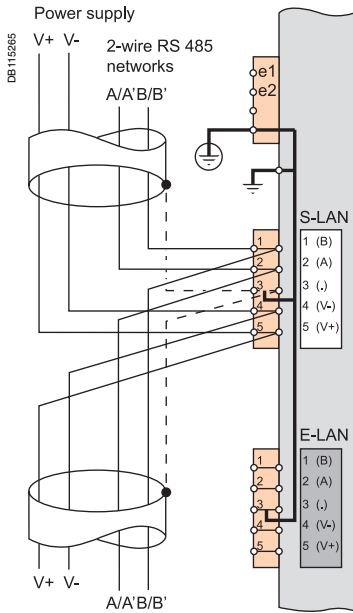

2-wire RS 485 communication ports (S-LAN or E-LAN)

- Connection of the RS 485 twisted pair (S-LAN or E-LAN) to terminals A and B
- In case of ACE 969TP wired with ACE969TP-2:
 - connection of twisted pair for distributed power supply to terminals 5(V+) et 4(V-)
- In case of ACE969TP-2 only:
 - connection only on the terminal 4(V-) (ground continuity)
 - no need of external power supply
- The cable shields must be connected to the terminals marked 3(.) on the connection terminal blocks.
- Terminal marked 3(.) are linked by an internal connection to the earthing terminals of the ACETP-2 interface (protective an functional earthing): I.e the shielding of the RS 485 cables is earthed as well.
- On the ACE960TP-2 interface, the cable clamps for the S-LAN and E-LAN RS 485 networks are earthed by the terminal 3.

If ACE969TP and ACE969TP-2 are used together, the external power supply is required.

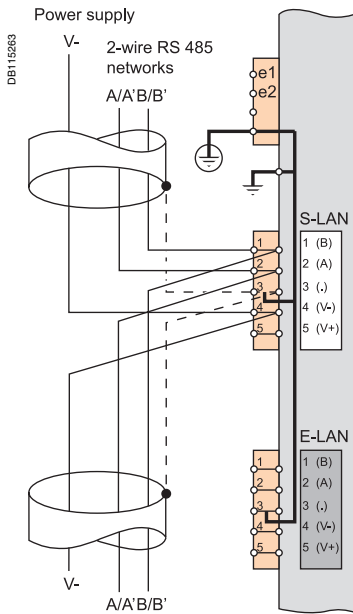

Fiber optic communication port (S-LAN)

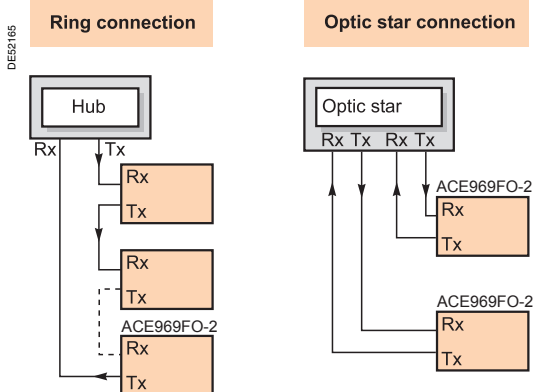

⚠ CAUTION

HAZARD OF BLINDING

Never look directly into the fiber optic.

Failure to follow this instruction can cause serious injury.

The fiber optic connection can be made:

- point-to-point to an optic star system
- in a ring system (active echo).

The sending and receiving fiber optic fibers must be equipped with male ST type connectors.

The fiber optics are screw-locked to Rx and Tx connectors.

ACE909-2 RS 232/RS 485 converter

1

PE60317



ACE909-2 RS 232/RS 485 converter.

Function

The ACE909-2 converter is used to connect a master/central computer equipped with a V24/RS 232 type serial port as a standard feature to stations connected to a 2-wire RS 485 network.

Without requiring any flow control signals, after the parameters are set, the ACE909-2 converter performs conversion, network polarization and automatic dispatching of frames between the master and the stations by two-way simplex (half-duplex, single-pair) transmission.

The ACE909-2 converter also provides a 12 V DC or 24 V DC supply for the distributed power supply of the Sepam ACE949-2, ACE959 or ACE969 interfaces. The communication settings should be the same as the Sepam and supervisor communication settings.

Characteristics

Mechanical characteristics

Weight	0.280 kg (0.617 lb)
Assembly	On symmetrical or asymmetrical DIN rail

Electrical characteristics

Power supply	110 to 220 V AC \pm 10%, 47 to 63 Hz
Galvanic isolation between ACE power supply and frame, and between ACE power supply and interface supply	2000 Vrms, 50 Hz, 1 min
Galvanic isolation between RS 232 and RS 485 interfaces	1000 Vrms, 50 Hz, 1 min
Protection by time-delayed fuse 5 mm x 20 mm (0.2 in x 0.79 in)	1 A rating

Communication and Sepam interface distributed supply

Data format	11 bits: 1 start, 8 data, 1 parity, 1 stop
Transmission delay	< 100 ns
Distributed power supply for Sepam interfaces	12 V DC or 24 V DC
Maximum number of Sepam interfaces with distributed supply	12

Environmental characteristics

Operating temperature	-5°C to +55°C (+23°F to +131°F)
-----------------------	---------------------------------

Electromagnetic compatibility

	IEC standard	Value
Fast transient bursts, 5 ns	60255-22-4	4 kV with capacitive coupling in common mode 2 kV with direct coupling in common mode 1 kV with direct coupling in differential mode
1 MHz damped oscillating wave	60255-22-1	1 kV common mode 0.5 kV differential mode
1.2/50 μ s impulse waves	60255-5	3 kV common mode 1 kV differential mode

⚠ DANGER

HAZARD OF ELECTRIC SHOCK, ELECTRIC ARC OR BURNS

■ Only qualified personnel should install this equipment. Such work should be performed only after reading this entire set of instructions and checking the technical characteristics of the device.

■ NEVER work alone.

■ Turn off all power supplying this equipment before working on or inside it. Consider all sources of power, including the possibility of backfeeding.

■ Always use a properly rated voltage sensing device to confirm that all power is off.

■ Start by connecting the device to the protective earth and to the functional earth.

■ Screw tight all terminals, even those not in use.

Failure to follow these instructions will result in death or serious injury.

ACE909-2 RS 232/RS 485 converter

Description and dimensions

- (A) Terminal block for RS 232 link limited to 10 m (33 ft).
- (B) Female 9-pin sub-D connector to connect to the 2-wire RS 485 network, with distributed power supply.
1 screw-type male 9-pin sub-D connector is supplied with the converter.
- (C) Power-supply terminal block

- 1 Distributed power supply voltage selector switch, 12 V DC or 24 V DC.
- 2 Protection fuse, unlocked by a 1/4 turn.
- 3 LEDs:
 - ON/OFF: on if ACE909-2 is energized
 - Tx: on if RS 232 sending by ACE909-2 is active
 - Rx: on if RS 232 receiving by ACE909-2 is active.
- 4 SW1, parameter setting of 2-wire RS 485 network polarization and line impedance matching resistors.

Function	SW1/1	SW1/2	SW1/3
Polarization at 0 V via Rp -470 Ω	ON		
Polarization at 5 V via Rp +470 Ω		ON	
2-wire RS 485 network impedance matching by 150 Ω resistor			ON

- 5 SW2, parameter setting of asynchronous data transmission rate and format (same parameters as for RS 232 link and 2-wire RS 485 network).

Rate (bauds)	SW2/1	SW2/2	SW2/3	SW2/4	SW2/5
1200	1	1	1		
2400	0	1	1		
4800	1	0	1		
9600	0	0	1		
19200	1	1	0		
38400	0	1	0		
Format				SW2/4	SW2/5
With parity check				0	
Without parity check				1	
1 stop bit (compulsory for Sepam)					0
2 stop bits					1

Converter configuration when delivered

- 12 V DC distributed power supply
- 11-bit format, with parity check
- 2-wire RS 485 network polarization and impedance matching resistors activated.

Connection

RS 232 link

- To 2.5 mm² (AWG 12) screw type terminal block (A)
- Maximum length 10 m (33 ft)
- Rx/Tx: RS 232 receiving/sending by ACE909-2
- 0V: Rx/Tx common, do not earth.

2-wire RS 485 link with distributed power supply

- To connector (B) female 9-pin sub-D
- 2-wire RS 485 signals: L+, L-
- Distributed power supply: V+ = 12 V DC or 24 V DC, V- = 0 V.

Power supply

- To 2.5 mm² (AWG 12) screw type terminal block (C)
- Reversible phase and neutral
- Earthed via terminal block and metal case (ring lug on back of case).

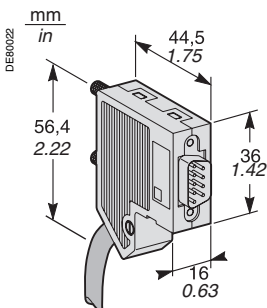
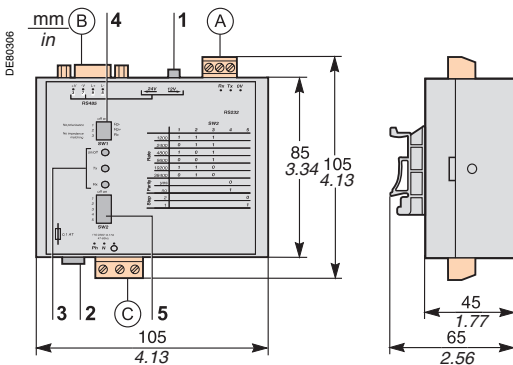

Male 9-pin sub-D connector supplied with the ACE909-2.

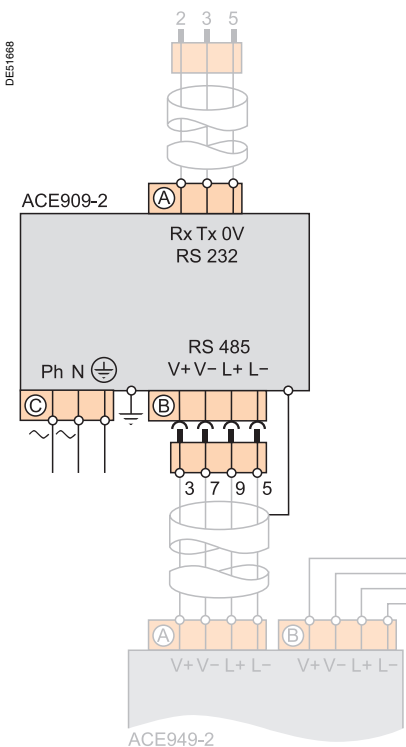

ACE919CA and ACE919CC RS 485/RS 485 converters

1

PE6016



ACE919CC RS 485/RS 485 converter.

Function

The ACE919 converters are used to connect a master/central computer equipped with an RS 485 type serial port as a standard feature to stations connected to a 2-wire RS 485 network.

Without requiring any flow control signals, the ACE919 converters perform network polarization and impedance matching.

The ACE919 converters also provide a 12 V DC or 24 V DC supply for the distributed power supply of the Sepam ACE949-2, ACE959 or ACE969 interfaces.

There are 2 types of ACE919 converter:

- ACE919CC, DC-powered
- ACE919CA, AC-powered.

Characteristics

Mechanical characteristics

Weight	0.280 kg (0.617 lb)	
Assembly	On symmetrical or asymmetrical DIN rail	

Electrical characteristics

	ACE919CA	ACE919CC
Power supply	110 to 220 V AC ±10%, 47 to 63 Hz	24 to 48 V DC ±20%
Protection by time-delayed fuse 5 mm x 20 mm (0.2 in x 0.79 in)	1 A rating	1 A rating
Galvanic isolation between ACE power supply and frame, and between ACE power supply and interface supply		2000 Vrms, 50 Hz, 1 min

Communication and Sepam interface distributed supply

Data format	11 bits: 1 start, 8 data, 1 parity, 1 stop	
Transmission delay	< 100 ns	
Distributed power supply for Sepam interfaces	12 V DC or 24 V DC	
Maximum number of Sepam interfaces with distributed supply	12	

Environmental characteristics

Operating temperature	-5°C to +55°C (+23°F to +131°F)	
-----------------------	---------------------------------	--

Electromagnetic compatibility

	IEC standard	Value
Fast transient bursts, 5 ns	60255-22-4	4 kV with capacitive coupling in common mode 2 kV with direct coupling in common mode 1 kV with direct coupling in differential mode
1 MHz damped oscillating wave	60255-22-1	1 kV common mode 0.5 kV differential mode
1.2/50 µs impulse waves	60255-5	3 kV common mode 1 kV differential mode

⚠ DANGER

HAZARD OF ELECTRIC SHOCK, ELECTRIC ARC OR BURNS

■ Only qualified personnel should install this equipment. Such work should be performed only after reading this entire set of instructions and checking the technical characteristics of the device.

■ NEVER work alone.

■ Turn off all power supplying this equipment before working on or inside it. Consider all sources of power, including the possibility of backfeeding.

■ Always use a properly rated voltage sensing device to confirm that all power is off.

■ Start by connecting the device to the protective earth and to the functional earth.

■ Screw tight all terminals, even those not in use.

Failure to follow these instructions will result in death or serious injury.

Description and dimensions

- (A) Terminal block for 2-wire RS 485 link without distributed power supply.
- (B) Female 9-pin sub-D connector to connect to the 2-wire RS 485 network, with distributed power supply. 1 screw-type male 9-pin sub-D connector is supplied with the converter.
- (C) Power supply terminal block.

- 1 Distributed power supply voltage selector switch, 12 V DC or 24 V DC.
- 2 Protection fuse, unlocked by a 1/4 turn.
- 3 ON/OFF LED: on if ACE919 is energized.
- 4 SW1, parameter setting of 2-wire RS 485 network polarization and line impedance matching resistors.

Function	SW1/1	SW1/2	SW1/3
Polarization at 0 V via Rp -470 Ω	ON		
Polarization at 5 V via Rp +470 Ω		ON	
2-wire RS 485 network impedance matching by 150 Ω resistor			ON

Converter configuration when delivered

- 12 V DC distributed power supply
- 2-wire RS 485 network polarization and impedance matching resistors activated.

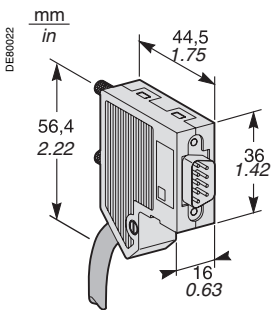
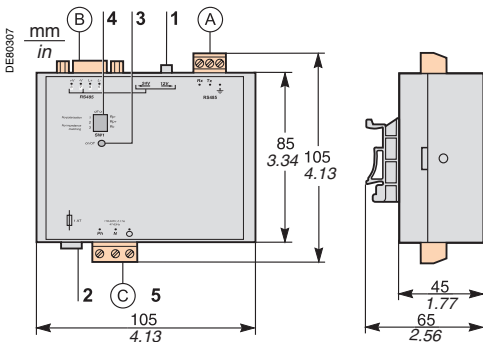

Male 9-pin sub-D connector supplied with the ACE919.

Connection

2-wire RS 485 link without distributed power supply

- To 2.5 mm² (AWG 12) screw type terminal block (A)
- L+, L-: 2-wire RS 485 signals
- ⚡ Shielding.

2-wire RS 485 link with distributed power supply

- To connector (B) female 9-pin sub-D
- 2-wire RS 485 signals: L+, L-
- Distributed power supply: V+ = 12 V DC or 24 V DC, V- = 0 V.

Power supply

- To 2.5 mm² (AWG 12) screw type terminal block (C)
- Reversible phase and neutral (ACE919CA)
- Earthed via terminal block and metal case (ring lug on back of case).

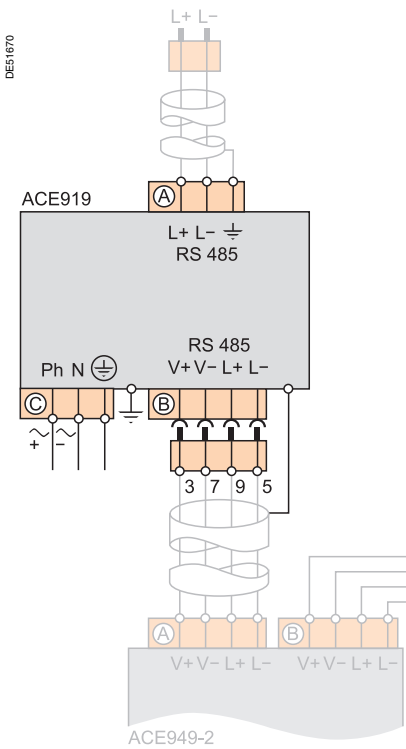

ECI850 IEC 61850 Sepam server

1

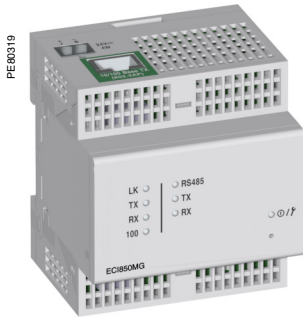

ECI850: IEC 61850 Sepam server.

Function

The ECI850 can be used to connect Sepam series 20, Sepam series 40 and Sepam series 80 to an Ethernet network using the IEC 61850 protocol.

The ECI850 creates the interface between the Ethernet/IEC 61850 network and a Sepam RS 485/Modbus network.

2 PRI surge arresters (ref. 16595) are supplied with the ECI850 to protect its power supply.

Compatible Sepam

The ECI850 servers are compatible with the following Sepam:

- Sepam series 20 version ≥ V0526
- Sepam series 40 version ≥ V3.00
- Sepam series 80 base version and application version ≥ V3.00.

Characteristics

ECI850 module	
Technical characteristics	
Weight	0.17 kg (0.37 lb)
Assembly	On symmetrical DIN rail
Power supply	
Voltage	24 V DC (± 10%) supplied by a class 2 power supply
Maximum consumption	4 W
Dielectric withstand	1.5 kV
Environmental characteristics	
Operating temperature	-25 °C to +70 °C (-13 °F to +158 °F)
Storage temperature	-40 °C to +85 °C (-40 °F to +185 °F)
Humidity ratio	5 to 95% relative humidity (non condensing) at +55 °C (131 °F)
Degree of pollution	Class 2
Tightness	IP30
Electromagnetic compatibility	
Emission tests	
Emissions (radiated and conducted)	EN 55022/EN 55011/FCC Class A
Immunity tests - Radiated disturbances	
Electrostatic discharge	EN 61000-4-2
Radiated radiofrequencies	EN 61000-4-3
Magnetic fields at the network frequency	EN 61000-4-8
Immunity tests - Conducted disturbances	
Fast transient bursts	EN 61000-4-4
Surges	EN 61000-4-5
Conducted radiofrequencies	EN 61000-4-6
Safety	
International	IEC 60950
USA	UL 508/UL 60950
Canada	cUL (complies with CSA C22.2, no. 60950)
Australia/New Zealand	AS/NZS 60950
Certification	
Europe	CE
2-wire/4-wire RS 485 communication port	
Electrical interface	
Standard	2-wire or 4-wire differential RS 485 EIA
Max. number of Sepam units	8
Maximum length of 2-wire/4-wire RS 485 network	
Number of Sepam units	Maximum length
5	1000 m (3300 ft)
8	750 m (2500 ft)
Ethernet communication port	
Number of ports	1
Type of port	10/100 Base Tx
Protocols	HTTP, FTP, SNMP, SNTP, ARP, SFT, IEC 61850 TCP/IP
Transmission speed	10/100 Mbps

Characteristics (continued)

PRI surge arresters	
Electrical characteristics	
Operating voltage	12 to 48 V
Maximum discharge current	10 kA (8/20 μs wave)
Nominal discharge current	5 kA (8/20 μs wave)
Protection level	70 V
Response time	< 25 ns
Indication of operation by mechanical indicator	
White	During normal operation
Red	Surge arresters MUST be changed
Connection	
With cage terminals	Cables with cross-section 0.5 to 2.5 mm ² (AWG 24-12)

Description

- 1 LED: power-up/maintenance
- 2 Standard LEDs:
 - RS 485 LED: network link active
 - On: RS 485 mode
 - Off: RS 232 mode
 - Flashing green Tx LED: ECI850 transmission active
 - Flashing green Rx LED: ECI850 reception active
- 3 Ethernet LEDs:
 - LK green LED on: network link active
 - Flashing green Tx LED: ECI850 transmission active
 - Flashing green Rx LED: ECI850 reception active
 - 100 green LED:
 - On: 100 Mbps network speed
 - Off: 10 Mbps network speed
- 4 10/100 Base Tx port for Ethernet connection by RJ45 connector
- 5 Connection of the 24 V DC supply
- 6 Reset button
- 7 RS 485 connection
- 8 RS 485 parameter-setting selector switches
- 9 RS 232 connection

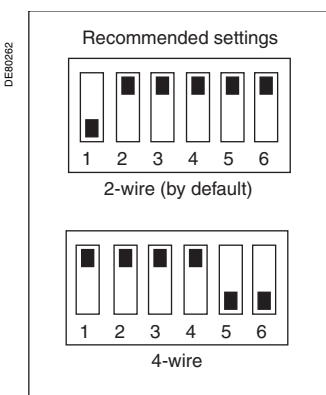
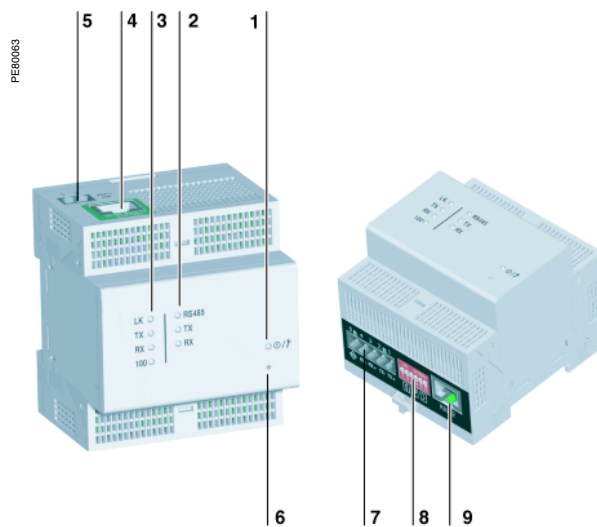

Setting the RS 485 network parameters.

Setting the RS 485 network parameters

The network polarization and line impedance matching resistors and type of 2-wire/4-wire RS 485 network are selected by means of the RS 485 parameter-setting selector switches. These selector switches are configured by default for a 2-wire RS 485 network with network polarization and line impedance matching resistors.

Network line impedance matching with resistor	SW1	SW2	SW3	SW4	SW5	SW6
2-wire RS 485	OFF	ON				
4-wire RS 485	ON	ON				

Network polarization	SW1	SW2	SW3	SW4	SW5	SW6
at the 0 V			ON			
at the 5 V				ON		

Selecting the RS 485 network	SW1	SW2	SW3	SW4	SW5	SW6
2-wire network					ON	ON
4-wire network					OFF	OFF

Setting the Ethernet link parameters

The TCSEAK0100 configuration kit can be used to connect a PC to the ECI850 to set the Ethernet link parameters.

Dimensions

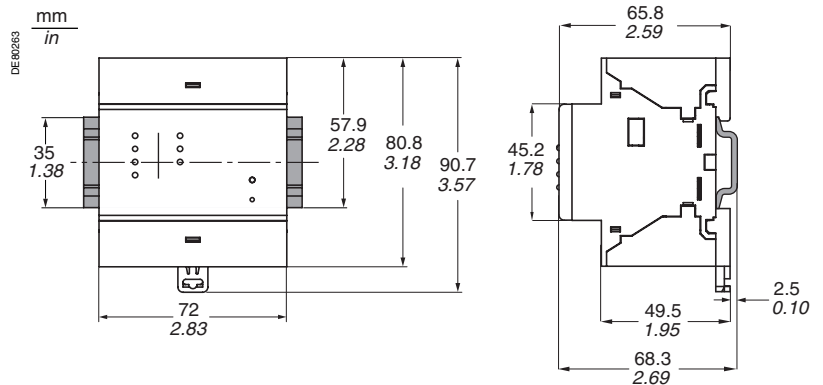

CAUTION

RISK OF DESTRUCTION OF THE ECI850

- Connect both the PRI surge arresters in accordance with the wiring diagrams below.
 - Check the quality of the earth connected to the surge arresters.
- Failure to follow these instructions can cause equipment damage.**

Connection

- Connect the power supply and RS 485 twisted pair using cable with cross-section $\leq 2.5 \text{ mm}^2$ ($\geq \text{AWG } 12$)
- Connect the 24 V DC power supply and the earth to inputs 1, 5 and 3 of the PRI surge arresters supplied with the ECI850
- Connect outputs 2 and 6 of the PRI surge arresters (ref. 16595) to the - and + terminals of the black screw terminal block
- Connect the RS 485 twisted pair (2-wire or 4-wire) to the (RX+ RX- or RX+ RX- TX+ TX-) terminals of the black screw terminal block
- Connect the RS 485 twisted pair shielding to the \oplus terminal of the black screw terminal block
- Connect the Ethernet cable to the green RJ45 connector

2-wire RS 485 network

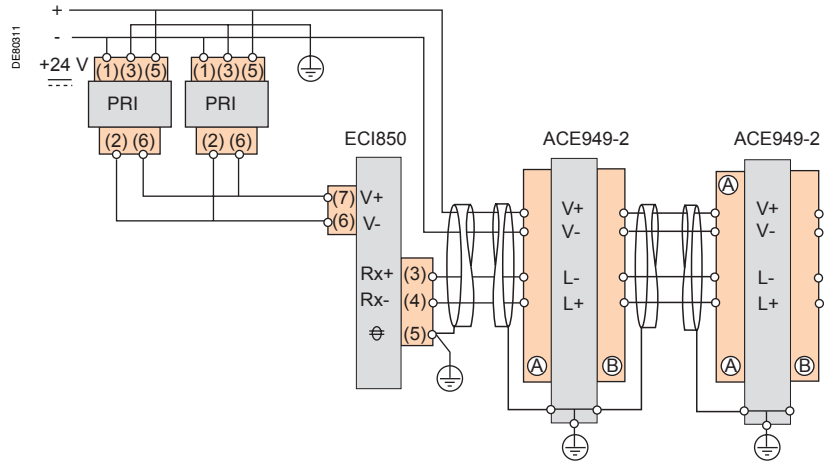

4-wire RS 485 network

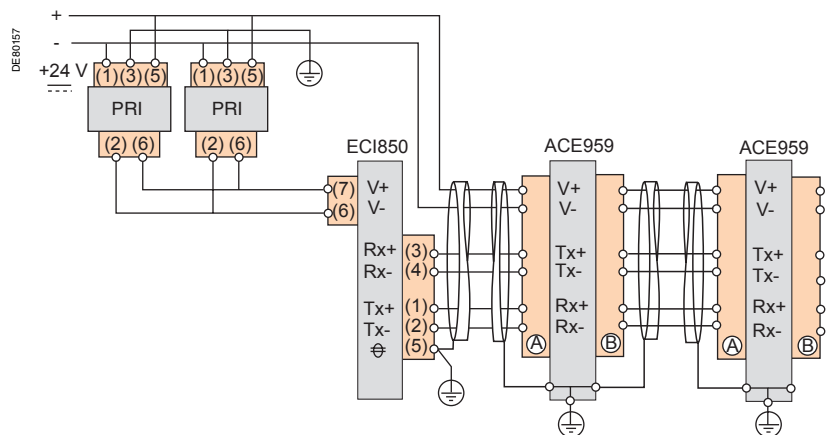

Example of architecture

The diagram below shows an example of the communication architecture with ECI850.

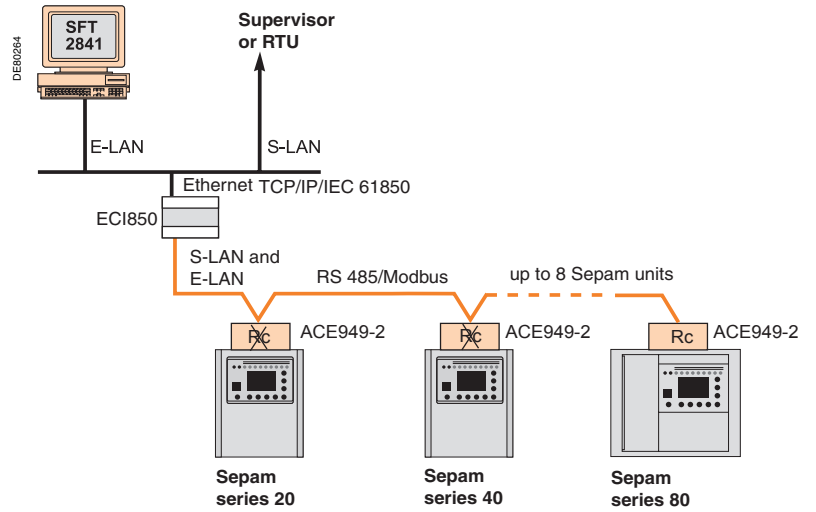

Nota : Rc, line impedance matching resistor

User-machine interfaces	74
Presentation	74
Selection guide	75
Description of the advanced UMI	76
Description of the mimic-based UMI	77
Local operation on the UMI	78
Types of operations and passwords	78
Display of operating information	79
Operating functions not requiring a password	81
Operating functions requiring a password	82
Entry of parameter and protection settings	83
Local control using the mimic-based UMI	85
SFT2841 setting and operating software	86
Welcome window	86
Presentation	87
General screen organization	88
Use of the software	90
Creation of user messages	91
Disturbance recording	92
Logic-equation editing	93
Set-up and operation of a Logipam program	94
Default settings	96
Configuration of a Sepam network	98
SFT2841 software Mimic-diagram editor	103
Presentation	103
General screen organization	105
Use	107

Two types of User-Machine Interfaces (UMI) are available for Sepam series 80 base units:

- mimic-based UMI
- advanced UMI.

The advanced UMI can be integrated in the base unit or installed remotely on the cubicle. Integrated and remote advanced UMIs offer the same functions.

A Sepam series 80 with a remote advanced UMI is made up of:

- a bare base unit without any UMI, for mounting inside the LV compartment
- a remote advanced UMI (DSM303)
 - for flush mounting on the front panel of the cubicle in the location most suitable for the facility manager
 - for connection to the Sepam base unit using a prefabricated CCA77x cord.

The characteristics of the remote advanced UMI module (DSM303) are presented on page 48.

Comprehensive data for facility managers

All the data required for local equipment operation may be displayed on demand:

- display of all measurement and diagnosis data in numerical format with units and/or in bar graphs
- display of operating and alarm messages, with alarm acknowledgment and Sepam resetting
- display of the list of activated protection functions and the main settings of major protection functions
- adaptation of activated protection function set points or time delays in response to new operating constraints
- display of Sepam and remote module versions
- output testing and logic input status display
- display of Logipam data: status of variables, timers
- entry of 2 passwords to protect parameter and protection settings.



Sepam series 80 base unit with integrated advanced UMI.

Local control of devices using the mimic-based UMI

The mimic-based UMI provides the same functions as the advanced UMI as well as local control of devices:

- selection of the Sepam control mode
- view device status on the animated mimic diagram
- local opening and closing of all the devices controlled by Sepam.

Ergonomic data presentation

- keypad keys identified by pictograms for intuitive navigation
- menu-guided access to data
- graphical LCD screen to display any character or symbol
- excellent display quality under all lighting conditions : automatic contrast setting and backlit screen (user activated).



Sepam series 80 base unit with mimic-based UMI.

Working language

All the texts and messages displayed on the advanced UMI or on the mimic-based UMI are available in 2 languages:

- English, the default working language
- and a second language, which may be
 - French
 - Spanish
 - another "local" language.

Please contact us regarding local language customization.

Connection of Sepam to the parameter setting tool

The SFT2841 parameter setting tool is required for Sepam protection and parameter setting.

A PC containing the SFT2841 software is connected to the RS 232 communication port on the front of the unit.



Customized Chinese advanced UMI.

User-machine interfaces

Selection guide

Base unit	With remote advanced UMI	With integrated advanced UMI	With mimic-based UMI
-----------	--------------------------	------------------------------	----------------------



2

Functions			
Local indication			
Metering and diagnosis data	■	■	■
Alarms and operating messages	■	■	■
List of activated protection functions	■	■	■
Main protection settings	■	■	■
Version of Sepam and remote modules	■	■	■
Status of logic inputs	■	■	■
Logipam data	■	■	■
Switchgear status on the animated mimic diagram			■
Phasor diagram of currents or voltages			■
Local control			
Alarm acknowledgement	■	■	■
Sepam reset	■	■	■
Output testing	■	■	■
Selection of Sepam control mode			■
Device open/close order			■
Characteristics			
Screen			
Size	128 x 64 pixels	128 x 64 pixels	128 x 240 pixels
Automatic contrast setting	■	■	■
Backlit screen	■	■	■
Keypad			
Number of keys	9	9	14
Control-mode switch			Remote / Local / Test
LEDs			
Sepam operating status	■ base unit: 2 LEDs visible on back ■ remote advanced UMI: 2 LEDs visible on front	2 LEDs, visible from front and back	2 LEDs, visible from front and back
Indication LEDs	9 LEDs on remote advanced UMI	9 LEDs on front	9 LEDs on front
Mounting			
	■ bare base unit, mounted at the back of the compartment using the AMT880 mounting plate ■ DSM303 remote advanced UMI module, flush mounted on the front of the cubicle and connected to the base unit with the CCA77x prefabricated cord	Flush mounted on front of cubicle	Flush mounted on front of cubicle

Integrated advanced UMI

Identifi- cation	Picto	Description
1		Green LED: Sepam on.
2		Red LED: Sepam unavailable.
3		9 yellow indication LEDs (L1 to L9 from left to right).
4		Label identifying the indication LEDs
5		Graphical LCD screen.
6		Display of measurements.
7		Display of switchgear, network and machine diagnosis data.
8		Display the alarm history.
9		Two-function key, depending on the screen displayed: ■ "Confirm" function for the entered values and selection.
10		Two-function key, depending on the screen displayed: ■ "Clear" function used to: □ acknowledge the active alarm □ reset the peak demand measurements and diagnosis information □ clear the alarm history ■ "Cursor up" function.
11		Two-function key: ■ key pressed for five seconds: LED and display test ■ key pressed briefly: Cursor down
12		Display of Sepam and Logipam data.
13		Display and adaptation of the settings of active protection functions.
14		Access to screen for password entry.
15		PC connection port.
16		Backup battery.
17		Protective battery cover.
18		Memory cartridge.
19		Door.

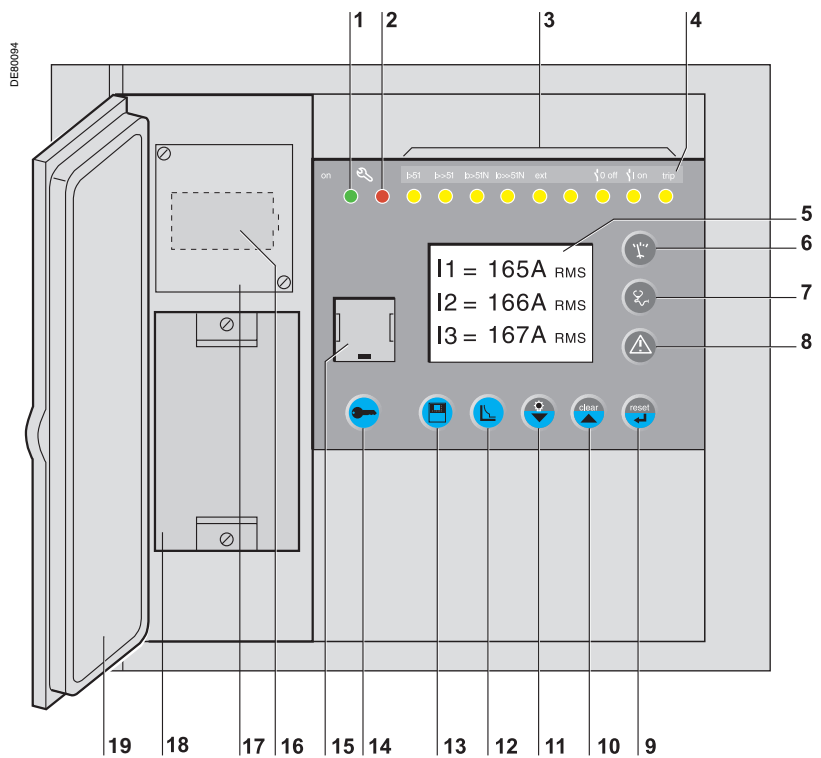

CAUTION
DAMAGE TO CARTRIDGE
 Do not install or remove the memory cartridge with the power on.
 Failure to follow this instruction can cause equipment damage.

DSM303 remote advanced UMI module

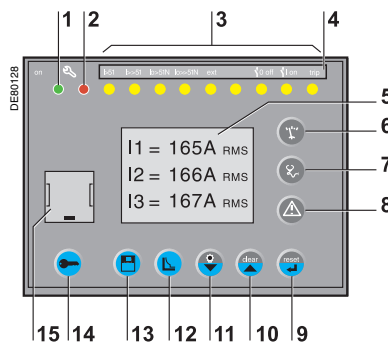

Description of the mimic-based UMI

Identification	Pictocaption	Description
1		Graphical LCD screen.
2		Green LED: Sepam on.
3		Red LED: Sepam unavailable.
4		Label identifying the indication LEDs
5		9 yellow indication LEDs (L1 to L9 from bottom to top).
6		Local closing of devices selected on the mimic-based UMI.
7		Local opening of devices selected on the mimic-based UMI.
8		Move cursor up.
9		Confirm data entry.
10		Move cursor down.
11		PC connection port.
12		Transparent door.
13		Access to screen for password entry.
14		Display the mimic-diagram.
15		Reset the latched information.
16		Display the alarm history.
17		Key used to: ■ acknowledge the active alarm ■ reset the peak demand measurements and diagnosis information ■ clear the alarm history.
18		Two-function key: ■ key pressed briefly: display of switchgear, network and machine diagnosis data. ■ key pressed for five seconds: LED and display test.
19		Display and adaptation of the settings of active protection functions.
20		Display of measurements and phasor diagram.
21		Display of Sepam and Logipam data.
22		Three-position key switch to select Sepam control mode: Remote, Local or Test.
23		Backup battery.
24		Protective battery cover.
25		Memory cartridge.
26		Door.

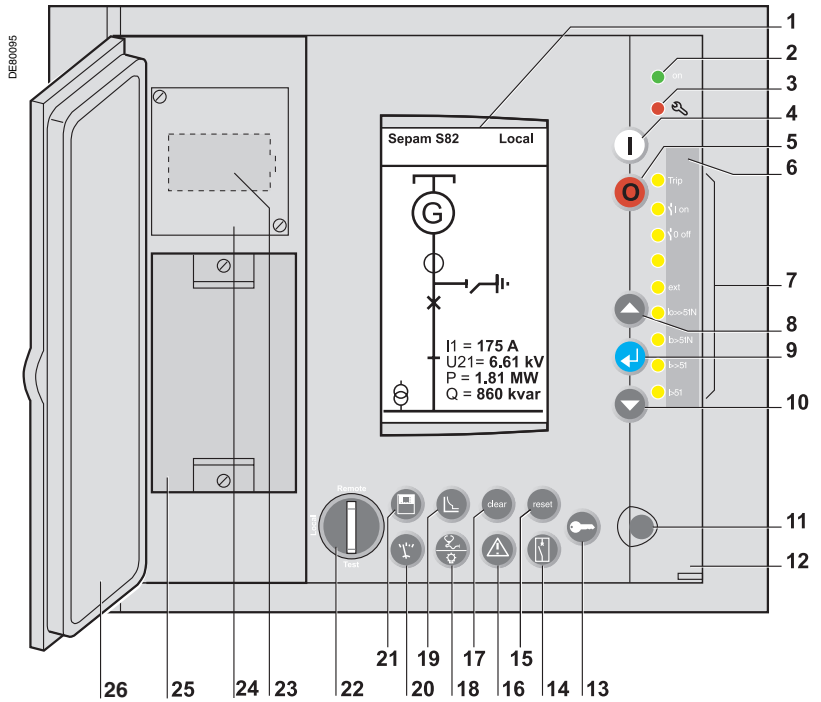

CAUTION
DAMAGE TO CARTRIDGE
 Do not install or remove the memory cartridge with the power on.
 Failure to follow this instruction can cause equipment damage.

Types of operations

The Sepam UMI can be used for three types of operations:

- normal operations: e.g., consult operating information, reset Sepam and acknowledge current alarms
- protection settings: e.g. modify the tripping set point of an active protection function
- modify Sepam parameters: e.g. change the operating language or set the internal clock.

Protection setting and parameter operations require a password.

Passwords

Protection setting and parameter operations are protected by two different passwords:

- password for protection settings
- password for parameter settings







The passwords have 4 digits.

The default passwords are 0000.

The table below indicates the operations authorized for each password.



Operations	No password	Protection-setting password	Parameter-setting password
Normal operation	■	■	■
Set the active protection functions		■	■
Modify Sepam parameters			■

Entry of passwords

1. Press the  key to access to screen for password entry.
2. Press the  key to position the cursor on the first digit.
3. Scroll the digits using the cursor keys  and .
4. Confirm to go on to the following digit by pressing the  key.
- (Do not use characters other than numbers 0 to 9 for each of the 4 digits.)
5. When the four digits have been entered, press the  key to position the cursor on [Apply].
6. Press the  key again to confirm.

Validity of passwords

Indication of password validity

- After entry of the protection-setting password, the  pictogram is displayed at the top of the screen.
- After entry of the parameter-setting password, the  pictogram is displayed at the top of the screen.

The pictogram remains displayed as long as the password is valid and the corresponding operations are authorized.

End of validity

A password is deactivated:

- by pressing the  key
- automatically if no keys are activated for more than 5 minutes.

Loss of passwords

Please contact our local after-sales service representative.

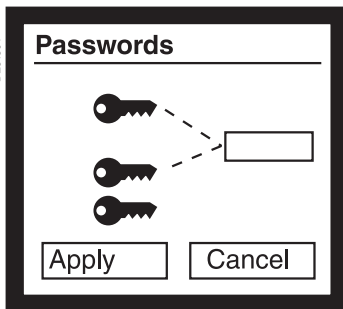

Screen for password entry.

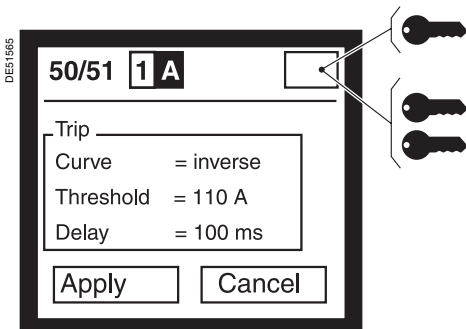

Indication of password validity on the display:





 = password for protection settings is valid.

 = password for parameter settings is valid.



Categories of operating information

Sepam operating information is grouped in five categories:

- measurements, accessed via the  key
- diagnosis data, accessed via the  key
- the alarm history, accessed via the  key
- Sepam and Logipam data, accessed via the  key
- the settings of active protection functions, accessed via the  key.



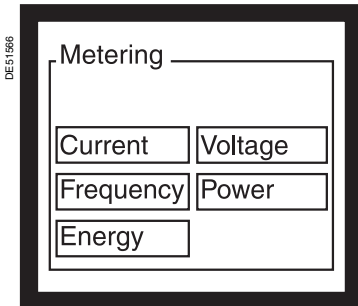

These five categories for the operating information are divided into subcategories to facilitate access to the desired information.

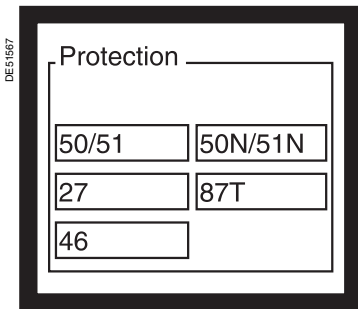

Selection screen for measurements.



Selection screen for active protection functions.

Key	Category of information	Sub-category
	Measurements	<ul style="list-style-type: none"> ■ Current ■ Voltage ■ Frequency ■ Power ■ Energy ■ Phasor (on mimic-based UMI only)
	Switchgear, network and machine diagnosis	<ul style="list-style-type: none"> ■ Diagnostic ■ Tripping context 0 (last recorded tripping context) ■ Tripping context -1 (next to last recorded tripping context) ■ Tripping context -2 ■ Tripping context -3 ■ Tripping context -4 ■ Out-of-sync context
	Alarm history (16 last recorded alarms)	<ul style="list-style-type: none"> ■ List of alarms in sets of four ■ Detailed information on individual alarms
	Sepam and Logipam data	<ul style="list-style-type: none"> ■ General information <ul style="list-style-type: none"> <input type="checkbox"/> identification of the base unit <input type="checkbox"/> minimum required version of SFT2841 software <input type="checkbox"/> general parameters <input type="checkbox"/> Sepam internal clock ■ Remote modules: <ul style="list-style-type: none"> <input type="checkbox"/> module identification ■ Inputs/outputs: <ul style="list-style-type: none"> <input type="checkbox"/> status and test of logic outputs <input type="checkbox"/> status of logic inputs ■ Logipam (if Logipam option is available): <ul style="list-style-type: none"> <input type="checkbox"/> identification of the Logipam program <input type="checkbox"/> configuration bits <input type="checkbox"/> counters
	Settings of active protection functions	Access to each individual protection function, by selecting its ANSI code

Example: measurement loop

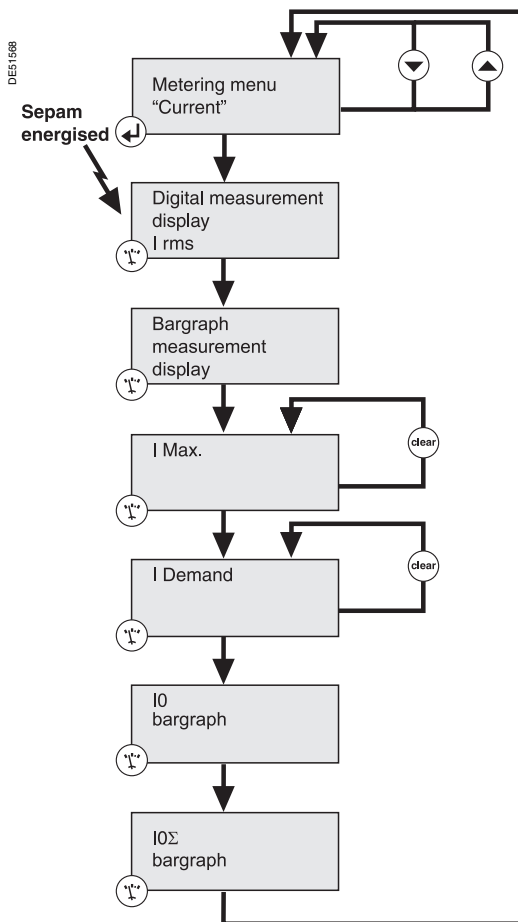

Access to operating information

- After selecting a category by pressing the corresponding key, a selection screen displays the subcategories.
- Select the subcategory with the cursor, using the \uparrow and \downarrow keys (the selected subcategory is displayed in inverse video).
- When the selection is validated by the \leftarrow key, the system displays the first screen presenting the operating information of the selected subcategory.
- Press again the key of the category displayed to go on to the next screen.
- The diagram opposite shows the progression in a given subcategory.
- When a screen cannot be completely displayed, use the \downarrow and \uparrow keys.



Local operation on the UMI

Operating functions not requiring a password

Reset the latched information

The  key is used to reset latched information. Sepam resetting must be confirmed. The alarm messages are not erased.

Acknowledge the active alarm

When Sepam displays an alarm, the  key is used to return to the screen displayed prior to the alarm or to a less recent unacknowledged alarm. The  key does not reset the latched information.

Reset the peak demand measurements

The following measurement and diagnosis information can be reset using the Sepam UMI:



- demand current
- peak demand current
- peak demand power.

Proceed as follows to reset the information:

1. Display the screen showing the information to be reset.
2. Press the  key.

Clear the alarm history

The alarm history (last 16 alarms) stored by Sepam can be cleared as follows:

1. Press the  key to display the alarm history.
2. Press the  key.

Test the LEDs and the display

The test on the LEDs and the display checks each LED and each pixel in the display.

Proceed as follows to run the test:

1. Press the  key for five seconds.
2. The nine LEDs go on successively in a predefined sequence.
3. Then the pixels in the display go on successively in a predefined sequence.

Local operation on the UMI

Operating functions requiring a password

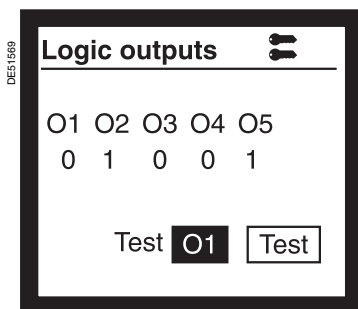

Screen presenting the logic outputs of the base unit and the status of each output, with the possibility of testing each output.

Reset the diagnosis information

The diagnosis information for certain protection functions can be reset using the Sepam UMI, after entering the parameter-setting password.

The information is listed below:

- the number of starts before inhibition, linked with the "Starts per hour" function (ANSI 66)
- heat rise calculated by the "Thermal overload" function (ANSI 49RMS).

Proceed as follows to reset the information:

1. Enter the password for parameter settings.
2. Display the screen showing the information to be reset.
3. Press the  key.

Test the logic outputs







It is possible to change the status of each logic output for five seconds. The check on logic-output connections and switchgear operation is thus simplified.

The screens on the logic outputs may be accessed in the "Sepam information" category, then in the "Inputs/outputs" subcategory.

The first screen presents the logic outputs of the base unit and up to three additional screens present the logic outputs of the additional MES120 modules.

A "Logic outputs" screen presents the status of all the logic outputs for a module and can be used, following entry of the parameter-setting password, to change the status of each output to check its operation.

Proceed as follows to test a logic output:

1. Enter the password for parameter settings.
2. Display the screen showing the logic output to be tested.
3. Go to the selection field for the output to be tested by pressing the  key.
4. Scroll the addresses of the logic outputs in the module using the cursor keys  and  to select the desired logic output.
5. Confirm the selected output by pressing the  key.
6. Press the  or  key to go on to the [Test] box.
7. Press the  key to change the status of the logic output for five seconds.

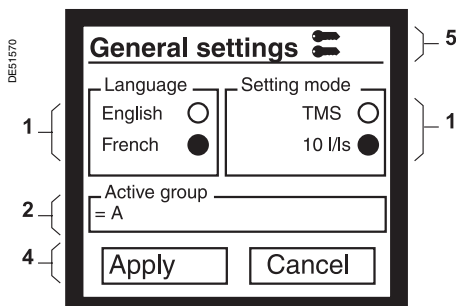

"General parameters" screen.

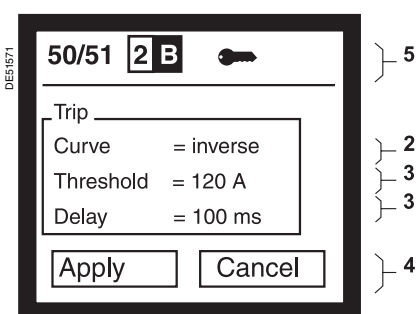

Setting screen for the "phase overcurrent" protection function (ANSI 50/51).

1. Boolean setting.
2. Selection of a value among a number of options.
3. Numerical value.
4. Boxes for final validation (Apply) or to cancel (Cancel) the procedure.
5. Pictogram indicating that the user is authorized to modify parameters and protection settings (after entry of the parameter-setting password).

Data entry principles

The principles behind the entry of parameter and protection settings are identical.

There are four steps in modifying parameter or protection settings using the Sepam UMI:

1. Enter the suitable password for either the protection or the parameter settings (see "Entry of passwords", page 78).
2. Display the screen with the value to be modified (see "Display of operating information", page 79).
3. Modify the values using one of the three entry methods offered, depending on the type of parameter or protection settings:
 - entry of Boolean values
 - selection of a value among a number of options
 - entry of numerical values
4. Final confirmation of all the new parameter or protection settings for use by Sepam.

Entry of Boolean values

Boolean parameters and protection settings are shown on the Sepam display as two buttons, representing the two status conditions of Boolean data.

For example, the language used for the operating texts on the Sepam UMI is a Boolean parameter that can have one of two states:

- English
- a local language (e.g. French).

To modify the value of a Boolean parameter or protection setting, proceed as follows:

1. Position the cursor using the \blacktriangledown and \blacktriangle keys.
2. Confirm the selection using the \blacktriangleleft key.

Selection of a value among a number of options

Certain parameters and protection settings must be selected from a finite number of possibilities.

For example, the type of tripping curve for the "phase overcurrent" protection function is selected from among 16 predefined curves (DT, SIT, VIT, EIT, etc.).

To select the desired parameter or protection setting, proceed as follows:

1. Position the cursor on the value to be modified using the \blacktriangledown and \blacktriangle keys.
2. Confirm using the \blacktriangleleft key.
3. Scroll the possibilities using the \blacktriangledown and \blacktriangle keys.
4. Confirm the new value by pressing the \blacktriangleleft key.

Entry of numerical values

Numerical parameters and protection settings are shown on the Sepam display as three digits, with or without the decimal point and the unit symbol.

To modify the value of a numerical parameter or protection setting, proceed as follows:

1. Position the cursor on the value to be modified using the \blacktriangledown and \blacktriangle keys.
2. Confirm by pressing the \blacktriangleleft key to position the cursor on the first digit.
3. Scroll the characters using the cursor keys \blacktriangledown and \blacktriangle : the available characters are the digits from 0 to 9, the decimal point and a space.
4. Confirm to go on to the following digit by pressing the \blacktriangleleft key.
5. After confirming the third digit, the cursor is positioned on the unit symbol.
6. Scroll the available units using the \blacktriangledown and \blacktriangle keys and confirm the selected unit by pressing the \blacktriangleleft key.

Local operation on the UMI

Entry of parameter and protection settings

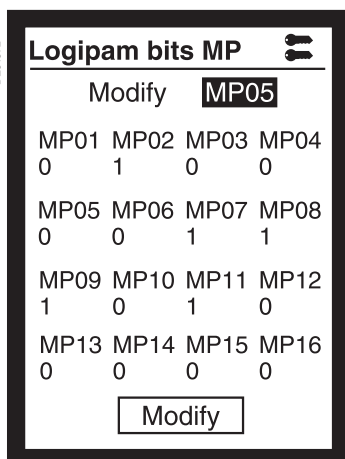



Screen for modification of Logipam configuration bits.

Final confirmation of modifications

After modifying one or more parameters or protection settings on a screen, confirmation is required before Sepam takes the modifications into account.

To confirm all the parameter and protection settings modified on a screen, proceed as follows:

1. Position the cursor on the [Apply] box at the bottom of the screen using the  key.
2. Confirm using the  key.

The new parameter or protection settings are taken into account by Sepam.

Modification of Logipam configuration bits







Logipam configuration bits are Boolean parameters that can be viewed and modified on the Sepam UMI.

The screens on the configuration bits may be accessed in the "Sepam information" category, then in the "Logipam" subcategory.

The 64 configuration bits MP01 to MP64 are presented in groups of 16 on four different screens.

A "Logipam bits MP" screen presents the status of 16 configuration bits and can be used, following entry of the parameter-setting password, to change the status of each bit.

Proceed as follows to modify a Logipam configuration bit:

1. Enter the password for parameter settings.
2. Display the screen showing the bit to be modified.
3. Go to the selection field for the bit to be modified by pressing the  key.
4. Scroll the addresses of the configuration bits using the cursor keys  and  to select the configuration bit to be modified.
5. Confirm the selected bit by pressing the  key.
6. Press the  or  key to go on to the [Modify] box.
7. Press the  key to change the status of the configuration bit.

Local operation on the UMI

Local control using the mimic-based UMI



Local control using the mimic-based UMI.

Sepam control mode

A key-switch on the mimic-based UMI is used to select the Sepam control mode. Three modes are available: Remote, Local or Test.

In Remote mode:

- remote control orders are taken into account
- local control orders are disabled, with the exception of the circuit-breaker open order.

In Local mode:

- remote control orders are disabled, with the exception of the circuit-breaker open order
- local control orders are enabled.

Test mode should be selected for tests on equipment, e.g. during preventive-maintenance operations:

- all functions enabled in Local mode are available in Test mode
- no remote indications (TS) are sent via the communication link.

The Logipam programming software can be used to customize control-mode processing.

View device status on the animated mimic diagram

For safe local control of devices, all information required by operators can be displayed simultaneously on the mimic-based UMI:

- single-line diagram of the equipment controlled by Sepam, with an animated, graphic indication of device status in real time
- the desired current, voltage and power measurements.





The local-control mimic diagram can be customized by adapting one of the supplied, predefined diagrams or by creating a diagram from scratch.

Local control of devices

All the devices for which opening and closing are controlled by Sepam can be controlled locally using the mimic-based UMI.

The most common interlock conditions can be defined by logic equations or by Logipam.

The sure and simple operating procedure is the following:

- select the Local or Test control mode
- select the device to be controlled by moving the selection window using the keys  or . Sepam checks whether local control of the selected device is authorized and informs the operator (selection window with a solid line).
- selection confirmation for the device to be controlled by pressing the key  (the selection window flashes).
- device control by pressing:
 - key : open order
 - or key : close order.

SFT2841 setting and operating software

Welcome window

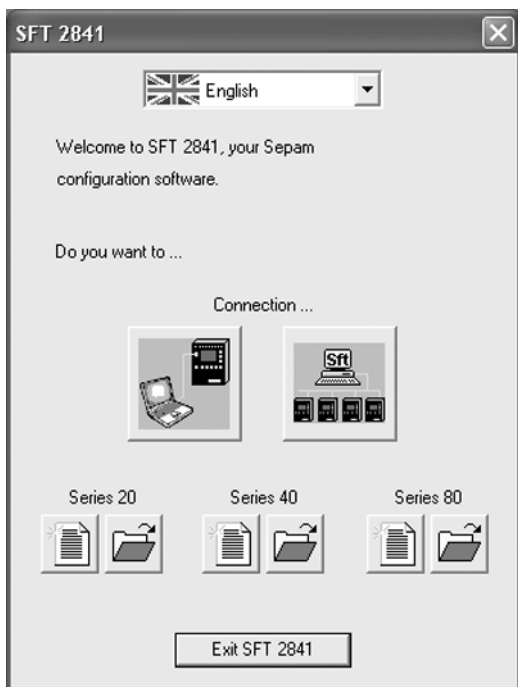

Welcome window.

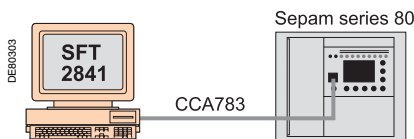

SFT2841 connected to a single Sepam unit with the serial port.

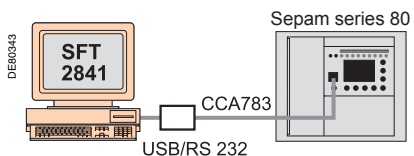

SFT2841 connected to a single Sepam unit with the USB port.

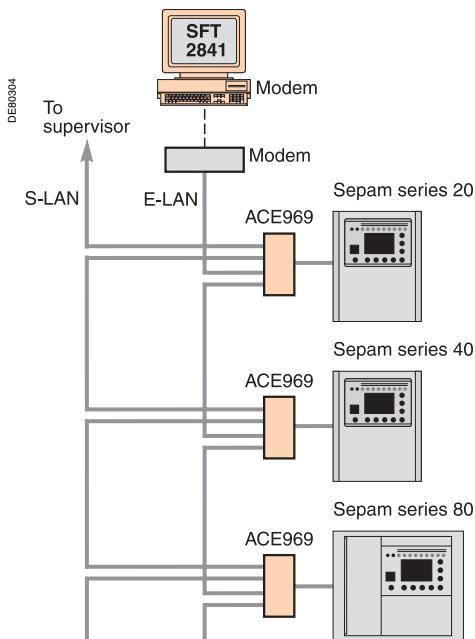

SFT2841 connected to a Sepam network.

Description

The SFT2841 welcome window opens when the program is launched.

It lets you choose the language for the SFT2841 screens, and provides access to the Sepam parameter and protection setting files:

- In disconnected mode, you can open or create a parameter and protection setting file for a Sepam series 20, Sepam series 40 or Sepam series 80
- When connected to a single Sepam unit, you can access the parameter and protection setting file for the Sepam unit connected to the PC
- When connected to a Sepam network, you can access the parameter and protection setting files for a group of Sepam units connected to the PC via a communication network.



Language of SFT2841 screens

SFT2841 software can be used in English, French or Spanish. The language is selected at the top of the window.

Using SFT2841 in disconnected mode

Disconnected mode allows you to prepare parameters and settings files for Sepam series 20, Sepam series 40 and Sepam series 80 prior to commissioning.

The parameter and protection setting files prepared in disconnected mode will be downloaded later to the Sepam units in connected mode.

- To create a new parameter and protection setting file, click on the icon  for the relevant Sepam family (Sepam series 20, Sepam series 40 or Sepam series 80)
- To open an existing parameter and protection setting file, click on the icon  for the relevant Sepam family (Sepam series 20, Sepam series 40 or Sepam series 80).

Using SFT2841 connected to a single Sepam unit

Connected to a single Sepam unit mode is used during commissioning:

- To upload, download and modify Sepam parameters and settings
 - To have all the measurements and supporting data available for commissioning.
- The PC fitted with the SFT2841 software is connected to the port on the front panel of the Sepam via an RS 232 port using the CCA783 cord. Connection to a USB port is possible if the TSXCUSB232 accessory is used in association with the CCA783 cable. The TSXCUSB232 accessory is ready to use since its driver is set-up during the SFT2841 software setup. To open the parameter and protection setting file on the Sepam once it is connected to the PC, click on the  icon.

Using SFT2841 connected to a Sepam network

Connected to a Sepam network mode is used during operation:

- To manage the protection system
- To check the status of the power supply
- To diagnose any incident occurring on the power supply.

The PC fitted with the SFT2841 software is connected to a group of Sepam units via a communication network (connection via serial link, telephone line or Ethernet). This network forms the E-LAN engineering network.

The connection window allows configuration of the Sepam network, and provides access to the parameter and protection setting files of the Sepam units on the network.

To open the connection window, click on the  icon.

See "Configuration of a Sepam network" page 101 for details of how to configure the E-LAN engineering network from the connection window.

SFT2841 setting and operating software Presentation

The SFT2841 software is used to set up and operate Sepam units. It operates in the Windows environment (XP or Vista).

All the data used for the same task are grouped in the same screen to facilitate operation. Menus and icons are used for fast, direct access to the data required.

Normal operation

- display of all metering and operation data
- display of alarm messages with the time of appearance (date, hour, min, s, ms)
- display of diagnosis data such as tripping current, number of switchgear operations and cumulative breaking current
- display of all protection and parameter settings
- display of the logic status of inputs, outputs and LEDs.

The SFT2841 software is the solution suited to occasional local operation, for demanding personnel who require fast access to all the information.

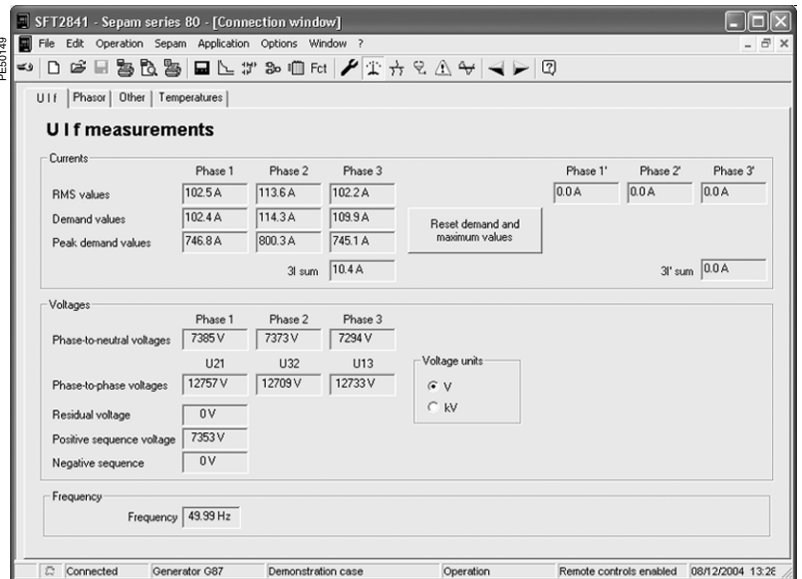

Example of a measurement display screen.

Parameter and protection settings (1)

- display and setting of all the parameters of each protection function on the same page
- set-up of general settings and Sepam data
- set-up of control and monitoring functions
- input data may be prepared ahead of time and transferred into the Sepam in a single operation (loading function).

Main functions performed by SFT2841

- changing of passwords
- entry of general settings (ratings, integration period, ...)
- entry of protection settings
- modification of assignments for control and monitoring functions
- enabling/disabling of functions
- entry of mimic-based UMI parameters
- saving of files.

Saving

- protection and parameter setting data may be saved
- printing of reports is possible as well.

The SFT2841 software may also be used to retrieve disturbance recording files and display them using the SFT2826 software tool.

Operating assistance

Access from all screens to a help section containing all the technical information needed to use and commission Sepam.

(1) Modes accessed via 2 passwords (protection setting level, parameter setting level).

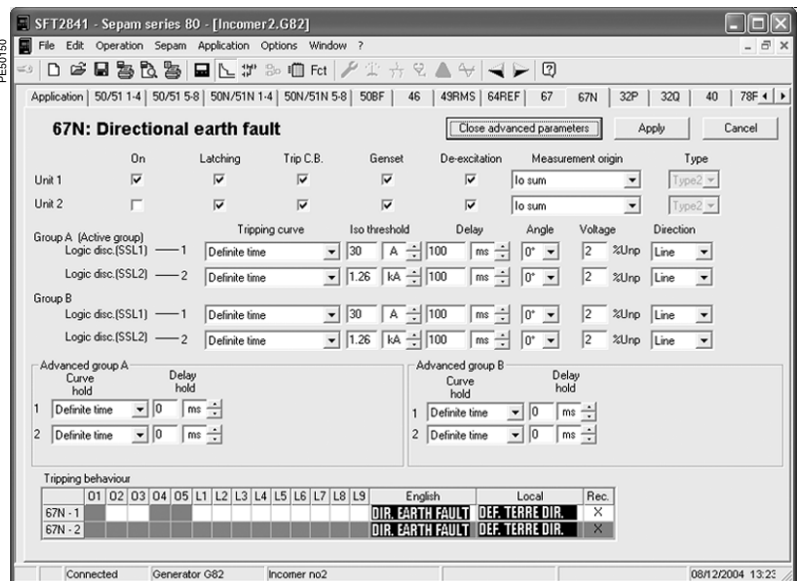

Example of a directional earth fault protection setting screen.

SFT2841 setting and operating software

General screen organization

A Sepam document is displayed on the screen via a graphic interface that has the conventional Windows features.

All the SFT2841 software screens are set up in the same way.

They include:

- 1 The title bar, with:
 - name of the application (SFT2841)
 - identification of the Sepam document displayed
 - corner symbols for window adjustments
- 2 The menu bar, for access to all the SFT2841 software functions (unavailable functions are dimmed).
- 3 The toolbar, a group of contextual icons for quick access to the main functions (also accessed via the menu bar).
- 4 The work zone available to the user, presented in the form of tab boxes.
- 5 The status bar, with the following information relating to the active document:
 - alarm on
 - identification of the connection window
 - SFT2841 operating mode, connected or not connected
 - type of Sepam
 - identification of Sepam edited
 - identification level
 - Sepam operating mode
 - PC date and time.

Guided navigation

A guided navigation mode is proposed to make it easier to enter all of the Sepam parameter and protection settings. It guides users through all data input screens in the natural order.

The sequencing of the screens in guided mode is controlled by clicking on 2 icons in the toolbar 3:

- ◀: to go back to the previous screen
- ▶: to go to the next screen.

The screens are linked up in the following order:

- 1 Sepam hardware configuration
- 2 General characteristics
- 3 CT/VT sensors
- 4 CT/VT circuit supervision
- 5 Particular characteristics
- 6 Control logic
- 7 Logic input/output assignments
- 8 Setting screens for the protection functions available, according to the type of Sepam
- 9 Logic equation editor or Logipam
- 10 Various tabs of the control matrix
- 11 Parameter setting of the disturbance recording function
- 12 Set-up of the mimic-based UMI

On-line help

The operator may look up on-line help at any time via the "?" command in the menu bar.

Acrobat Reader is required for on-line help. It is provided on the CD.

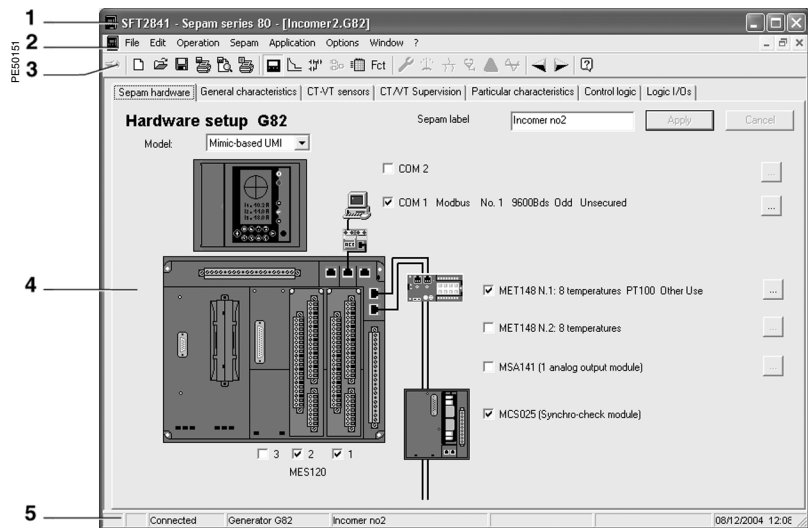



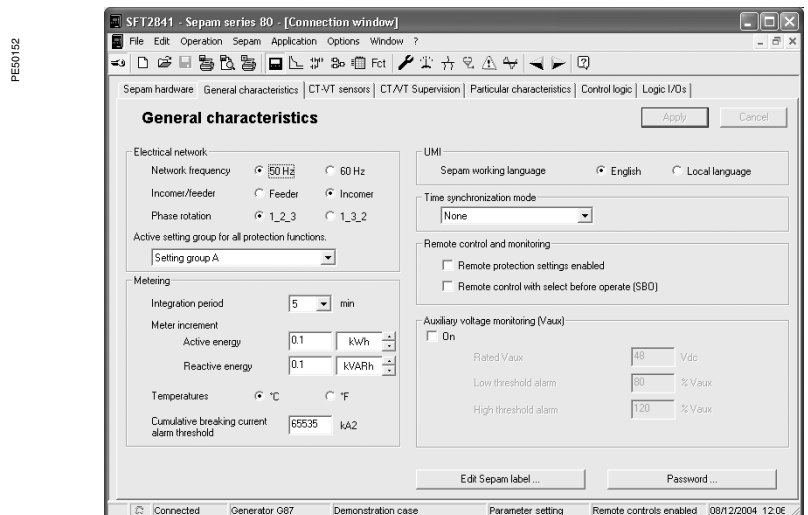









Example of hardware configuration screen.









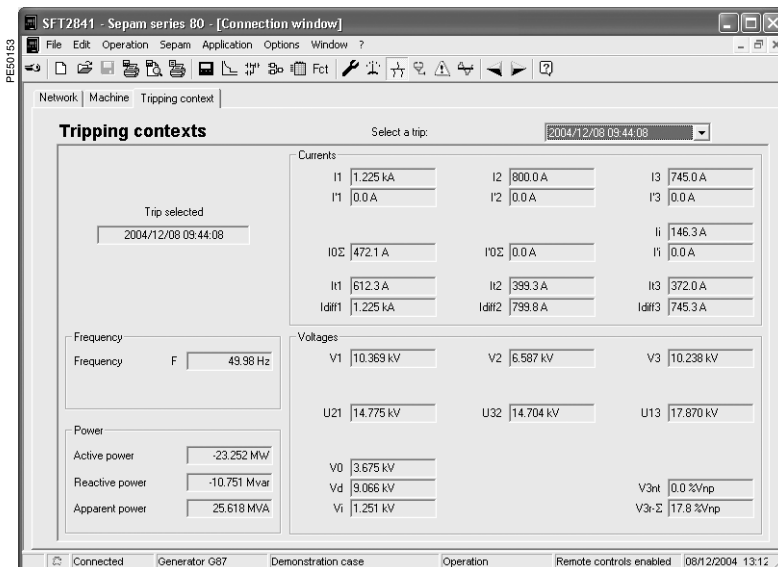

Example of general characteristics screen.

Details of the different screens

-  identification: entry of the password gives the user access rights to the parameter and protection setting mode (valid for 5 minutes)
-  selection of a new application from a list of application files with factory settings. The file suffix identifies the application.
e.g.: "appli.G87" is for a Generator 87 application
-  opening of an existing application which, in principle, should be located in the "Sepam" sub-directory of the "SFT2841" directory. A type of application may be selected by choosing the type of file (e.g.: file type *.S80, or *. G87 or *.* to obtain the complete list of files)
-  saving of an application: go to the "Sepam" sub-directory of the "SFT2841" directory, and name the file. The application suffix is updated automatically
-  configuration and complete or partial printing of the current configuration file
-  print preview of the configuration file
-  hard-copy of the current screen
-  Sepam parameter setting:
 - "Sepam hardware" tab: hardware configuration.
 - "General characteristics" tab: setting of the network, remote control and monitoring, password management and Sepam label printing parameter
 - "CT/VT sensors" tab: configuration of current and voltage sensors
 - "CT/VT supervision" tab: implementation and configuration of CT and VT sensor supervision
 - "Particular characteristics" tab: parameter setting of transformer, motor/generator rotation speed
 - "Control logic" tab: parameter setting of the switchgear control, logic discrimination, genset shutdown, de-excitation, load shedding and restart functions
 - "Logic I/Os" tab: management of logic input and output assignment
-  protection functions:
 - "Application" tab: overview of the protection functions available in the application with graphical view of the single-line diagram. A double click on a protection function label gives quick access to the setting tab
 - 1 tab per protection function: setting of the parameters of each protection function, with a mini-matrix for setting of the outputs, LEDs and disturbance recording
-  creation of logic equations: see description in "Control and monitoring functions" chapter
-  Logipam: set-up and operation of the Logipam program used. The program must first be entered and confirmed using the SFT2885 software.
-  control matrix: used to assign logic outputs, LEDs and messages to information produced by the protection units, logic inputs and logic equations. This function may also be used to create messages. See "Creation of user messages".



Example of tripping contexts screen.

-  special functions:
 - "Rec" tab: parameter setting of the disturbance-recording function
 - "Mimic-based UMI" tab: parameter setting of the mimic-based UMI
-  (1) Sepam diagnosis:
 - "Diagnosis" tab: general characteristics, software version, fault indicator and Sepam time-setting
 - "Input, output and LED status" tab: gives status and proposes an output test
 - "Remote indication status" tab: remote indication status
-  (1) main measurements:
 - "UIF" tab: voltage, current and frequency values
 - "Other" tab: power, energy and rotation speed values
 - "Temperatures" tab
-  (1) diagnosis:
 - "Network" tab: unbalance / negative sequence, V-I phase displacement, number of phase and earth trips and total harmonic distortion values
 - "Machine" tab: running hours counter, differential and through current, impedance, I-I' phase displacement, H3 voltage and thermal overload values
 - "Tripping context" tab: gives the last 5 tripping contexts
-  (1) switchgear diagnosis: cumulative breaking current, auxiliary voltage and circuit breaker data
-  (1) management of alarms with history and time-tagging
-  (1) disturbance recording: this function is used to record analog signals and logical states. See "Disturbance recording".
-  guided navigation: see previous page
-  on-line help: see previous page

(1) These icons are only accessible in "connected to Sepam" mode.

Disconnected mode

Sepam parameter and protection setting

Sepam parameter and protection setting using SFT2841 consists of preparing the Sepam file containing all the characteristics that are specific to the application, a file that is then loaded into Sepam at the time of commissioning.

⚠ CAUTION

RISK OF UNINTENDED OPERATION

- The device must only be configured and set by qualified personnel, using the results of the installation protection system study.
- During commissioning of the installation and following any modification, check that the Sepam configuration and protection function settings are consistent with the results of this study.

Failure to follow these instructions can result in equipment damage.

Operating procedure:

1. Create a Sepam file for the type of Sepam to be set up (the newly created file contains the factory settings of the Sepam parameters and protection functions).
2. Modify the Sepam general settings and protection function settings:
 - all the data relating to the same function are grouped together in the same screen
 - it is advisable to enter all the parameters and protection settings in the natural order of the screens proposed by the guided navigation mode.

Entry of parameter and protection settings

- the parameter and protection setting input fields are suited to the type of value:
 - choice buttons
 - numerical value input fields
 - dialogue box (Combo box)
- the user must "Apply" or "Cancel" the new values entered before going on to the following screen
- the consistency of the new values applied is checked:
 - an explicit message identifies inconsistent values and specifies the allowable values
 - values that have become inconsistent following a parameter modification are adjusted to the closest consistent value.

Connected mode

Precaution

When a laptop is used, given the risks inherent to the accumulation of static electricity, the customary precaution consists of discharging in contact with an earthed metal frame before physically connecting the CCA783 cord.

Note : If you are unable to connect to Sepam, check that the SFT2841 software version used is actually compatible with your Sepam. See "Compatibility of Sepam version/SFT2841 version" on page 142.

Plugging into Sepam

- plugging of the 9-pin connector (SUB-D type) into one of the PC communication ports.
Configuration of the PC communication port via the "Communication port" function in the "Options" menu.
Connection to a USB port on the PC is possible if the TSXCUSB232 accessory is used in association with the CCA783 cable.
- plugging of the 6-pin connector into the connector (round MiniDin type) situated behind the blanking plate on the front panel of Sepam or the DSM303 module.

Connection to Sepam

2 possibilities for setting up the connection between SFT2841 and Sepam:

- "Connection" function in the "File" menu
- choice of "connect to the Sepam" at the start-up of SFT2841.
Once the connection with Sepam has been established, "Connected" appears in the status bar, and the Sepam connection window may be accessed in the work zone.

User identification

The window intended for the entry of the 4-digit password is activated:

- via the "General characteristics" tab, "Passwords" button...
- via the "Identification" function in the "Sepam" menu.
The "Return to Operating mode" function in the "Passwords" tab withdraws access rights to the parameter and protection setting mode.

Loading of parameters and protection settings

Parameter and protection setting files may only be loaded in the connected Sepam in Parameter setting mode.

Once the connection has been established, the procedure for loading a parameter and protection setting file is as follows:

1. Activate the "Load Sepam" function in the "Sepam" menu
2. Select the file (*.S80, *.S81, *.S82, *.S84, *.T81, *.T82, *.T87, *.M81, *.M87, *.M88, *.G82, *.G87 or *.G88, *.B80, *.B83, *.C86, according to the type of application) which contains the data to be loaded.

Return to factory settings

This operation is only possible in Parameter setting mode, via the "Sepam" menu. All of the Sepam general settings, protection settings and the control matrix go back to the default values.

The return to factory settings does not erase the logic equations.

The logic equation editor must be used to delete them.

Unloading of parameter and protection settings

The connected Sepam parameter and protection setting file may only be unloaded in Operating mode.

Once the connection has been established, the procedure for unloading a parameter and protection setting file is as follows:

1. Activate the "Unload Sepam" function in the "Sepam" menu
2. Select the *.rpg file that is to contain the unloaded data
3. Acknowledge the end of operation report.

Local operation of Sepam

Connected to Sepam, SFT2841 offers all the local operating functions available in the advanced UMI screen, plus the following functions:

- setting of Sepam's internal clock, via the "Sepam diagnosis" tab
- implementation of the disturbance recording function: enabling/disabling of the function, retrieval of Sepam files, start-up of SFT2826
- consultation of the history of the last 250 Sepam alarms, with time-tagging
- access to Sepam diagnostic data, in the "Sepam" tab box, included in "Sepam diagnosis"
- in Parameter setting mode, switchgear diagnosis values may be modified: operation counter and cumulative breaking current to reset the values after a breaking device is changed.

SFT2841 setting and operating software

Creation of user messages

This operation is carried out using the control matrix ( icon or "Application / Set control matrix" menu).

When the matrix is displayed, select the "Events" tab, double-click on the empty box of the message to be created, or on an existing message to modify it.

A new screen may be used to:

- create a new user message:

- modify the message you have created or an existing user message:

1. Select the message number in the "No." column.

2. Click on the "Modify" button.

3. An editing or bitmap window may be used to create text or drawings.

- assign the message to the line in the control matrix:

1. Select "message" if it has not already been selected.

2. Select the new predefined or user message in the corresponding "No." column.

3. Click on "Assign".

4. Confirm your choice by clicking on the "OK" button.

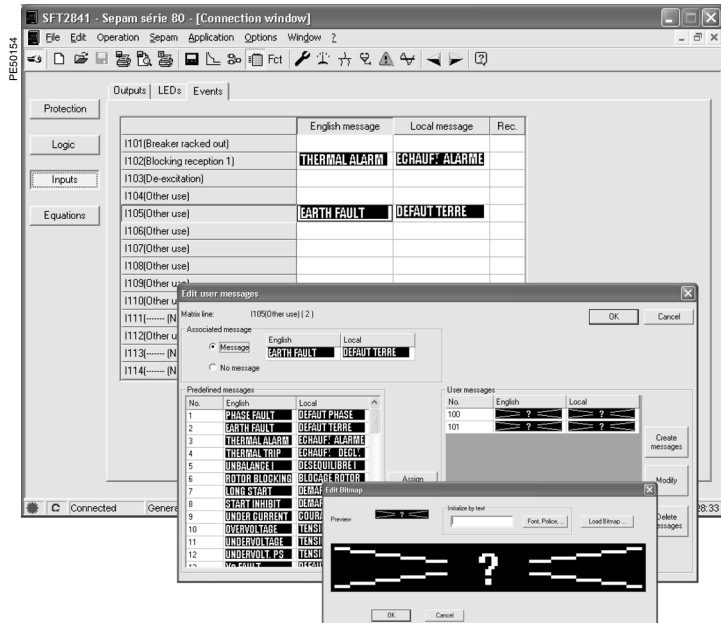

Example of message creation screen.

SFT2841 setting and operating software

Disturbance recording

Disturbance recording is set up using the  icon.

1. Activate the function.
 2. Set the following:
 - number of recordings
 - duration of each recording
 - number of samples stored per period
 - number of Pretrig periods (number of periods stored before the disturbance recording triggering event).
 3. Then make up the list of logic I/Os that should appear in the disturbance recording.
- If one of the parameters is changed: number of recordings, duration of a recording, number of Pretrig periods, all the recordings already saved will be erased (a warning message is displayed). Changes made in the list of logic I/Os do not affect existing recordings.
4. Click on the "Apply" button.

Disturbance recordings may be displayed by clicking on the  icon.
Each recording is identified in the list by the date.

Manual disturbance recording: click on the "New recording" button and a new dated item appears in the list.

Displaying recordings: select one or more disturbance recordings, and click on the "Retrieve" button. This activates the SFT2826 software for display of the disturbance recording files by selecting the "file" menu, "open" command.

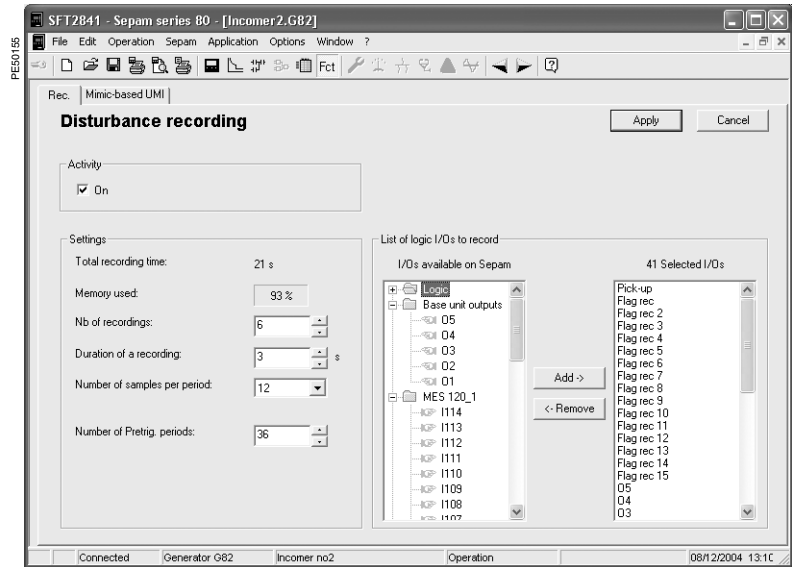

Example of disturbance recording configuration screen.

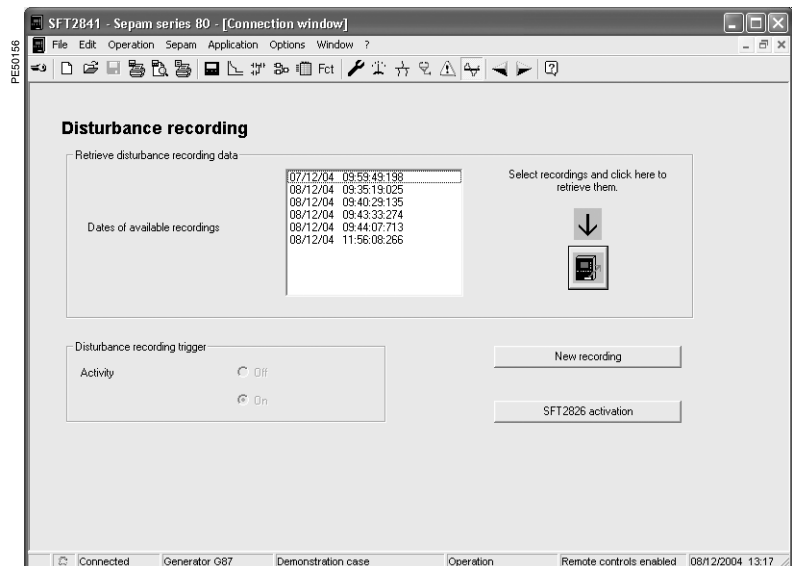

Example of disturbance recording display screen.

SFT2841 setting and operating software

Logic-equation editing

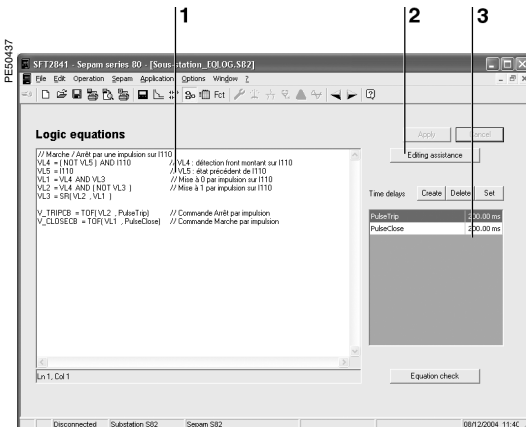

Logic-equation editor screen.

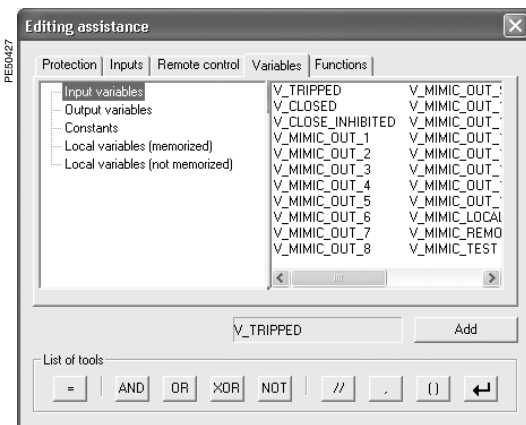

Editing assistance tool.

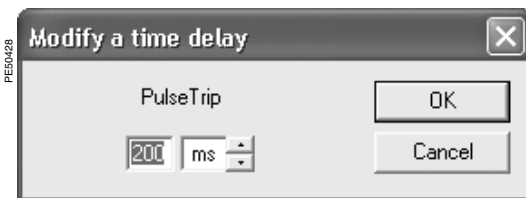

Time delay editor.

Presentation

Logic-equation editing consists of:

- entry and checks on logic equations
- setting the delays used in the logic equations
- loading the logic equations in Sepam.

The logic-equation editor of the SFT2841 software is accessed via the  icon. It is authorized only when the Logipam program linked to the Sepam configuration is not installed.

The logic-equation editor includes:

- 1 a zone to enter and display the logic equations
- 2 an editing assistance tool
- 3 a tool for setting time delays.

Entry of logic equations

The syntax required for logic equations is presented in the manual on Sepam series 80 functions, in the "Control and monitoring functions" section.

Logic equations are entered in text:

- directly in the equation entry zone
- or using the editing assistance tool.

The editing assistance tool offers guided access to variables, operators and functions. Via the tab sheets and tree structures, the user can select program elements and then click the "Add" button. The selected element is placed in the entry zone.

Check on the logic equations

The syntax of logic equations can be checked by clicking:

- the "Equation check" button during entry of logic equations
- the "Apply" button during final confirmation of the logic equations entered.

An error message is displayed if the check detects an error. The message indicates the type of error and the line containing the error.

Setting time delays

Time delays can be entered directly in a logic equation.

Example: $V1 = \text{TON}(VL1, 100)$, "On" time delay, set to delay the shift to 1 of variable VL1 by 100 ms.

To improve equation legibility and facilitate time delay settings, it is preferable to use the time delay editor to:

- create a time delay, indicating its duration and name (used in writing the logic equation)
- delete a time delay
- adjust a time delay by modifying its duration without having to make changes in the equation entry zone
- display the list of delays used in the logic equations, with their names and durations.

Example:

Create SwitchOnDelay with a duration of 100 ms.

In the entry zone, use the time delay: $V1 = \text{TON}(VL1, \text{SwitchOnDelay})$.

Load the logic equations in Sepam

Logic equations are transferred to Sepam in connected mode:

- directly by clicking the "Apply" button
- when a configuration file containing logic equations entered in disconnected mode is loaded.

In both cases, loading results in a short interruption in Sepam operation and automatic restart at the end of loading.

SFT2841 setting and operating software

Set-up and operation of a Logipam program

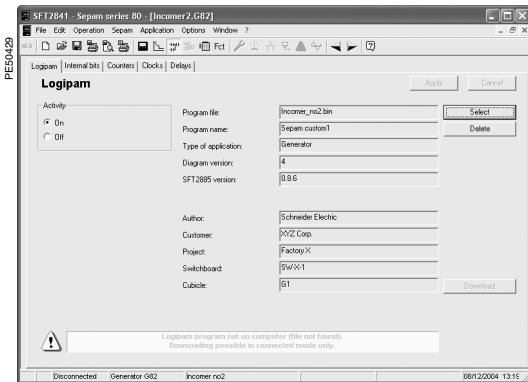

Logipam screen.

Presentation

The Logipam screen in the SFT2841 software is used to:

- link a Logipam program to the configuration of a Sepam
- set program parameters
- view the internal program variables to assist in program set-up.

The Logipam program must first be entered and confirmed using the SFT2885 software.

The Logipam screen of the SFT2841 software is accessed via the  icon.

The Logipam screen can be accessed in connected mode with a Sepam if the latter has the Logipam SFT080 option. In disconnected mode, the Logipam screen is still accessible, but the configuration files containing a Logipam program can be loaded exclusively to Sepam units with the SFT080 option.

The Logipam screen has five tabs:

- Logipam: selection of the program and its operating mode
- Internal bits: view the internal bits and set the configuration bits
- Counters: view the current value and set the counters
- Delays: view the state and set the timers
- Clocks: set the clocks.

Link a Logipam program to the configuration of a Sepam

A Logipam program is linked to the configuration of a Sepam by selecting the program file using the "Select" button on the Logipam tab sheet.

The programs are stored in the Logipam subdirectory of the SFT2841 installation directory (by default C:\Program Files\Schneider\SFT2841\Logipam). They have the extension .bin.

Once the program has been selected, the program properties are indicated (name, version, author, installation characteristics, etc.).

The "Apply" button is used as indicated below:

- In disconnected mode, it stores the name of the Logipam program in the Sepam configuration file.

The program is then loaded in Sepam at the same time as the configuration file.

- In connected mode, it stores the name of the Logipam program in the Sepam configuration file and loads the program in Sepam.

The "Delete" button eliminates the link between the Logipam program and the configuration file.

In connected mode, the name of the Logipam program is deleted in the Sepam memory cartridge when the "Apply" button is clicked.

The operating mode of the Logipam must be selected:

- On: the program runs immediately after it is loaded
 - Off: the program does not run and program outputs remain set to 0.
- Processing by the Logipam program can thus be temporarily postponed, e.g. if the program has not yet been fully set up.

SFT2841 setting and operating software

Set-up and operation of a Logipam program

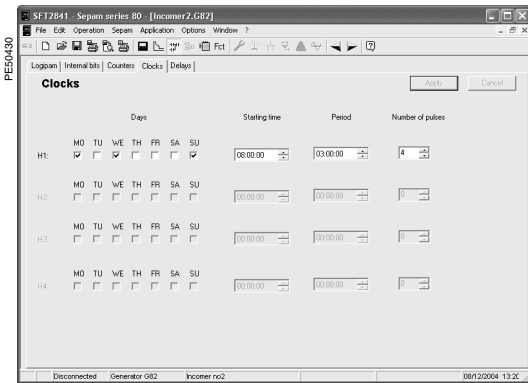

Logipam clock settings screen.

Set up a Logipam program

The following Logipam information can be set up using the SFT2841 software, on the tab sheets of the Logipam screen, to adapt the program to user needs:

- values of the configuration bits
- duration of time delays
- values of the timer bits
- counter set points
- clock settings

The set values are saved similar to the other Sepam parameters, i.e. to the configuration file in disconnected mode and to the Sepam in connected mode.

View the internal data of the Logipam program

The following information can be viewed on the tab sheets of the Logipam screen, to check program operation:

- values of the configuration bits
- values of the saved internal bits
- values of the non-saved internal bits
- current counter values.

Update a Logipam program

The SFT2841 continuously checks whether a more recent version of the Logipam program is available. If that is the case, it proposes an update on the Logipam tab sheet, with two options:

- maintain all settings as modified using the SFT2841 program or the Sepam display
- return to the default settings set up in the program.

Download the Logipam program

The Logipam program can be downloaded from Sepam by clicking the "Download" button on the Logipam tab sheet. Once downloaded, the program can be imported by the SFT2885 software to be viewed and modified.

SFT2841 setting and operating software

Default settings

The default settings (or factory settings) are present in Sepam the first time it is used. It is possible to go back to the Sepam default settings at any time by using the "Factory settings" function in the SFT2841 software. These settings are also used to initialize the SFT2841 software setting files.

Parameter	Default value
Hardware configuration	
Model	Integrated UMI
Identification	Sepam xxx
COM1, COM2	Off
MET148-2 No. 1, 2	Off
MSA141	Off
MES120 No. 1, 2, 3	Off
MCS025	Off
General characteristics	
Frequency	50 Hz
Incomer/feeder	S80, S81, S82, S84, M81, M87, M88, B80, B83, C86 applications: feeder G82, G87, G88, T81, T82, T87 applications: incomer
Phase rotation direction	1_2_3
Group of settings	Group A
Remote protection setting enabled	Off
Remote control with select before operate (SBO)	Off
Integration period	5 min
Active-energy increment	0.1 kWh
Reactive-energy increment	0.1 kVARh
Temperature	°C
Sepam working language	English
Time synchronization mode	None
Auxiliary voltage monitoring	Off
Protection setting password	0000
Parameter setting password	0000
Cumulative breaking current alarm threshold	65535 kA ²
CT-VT sensors	
Single-line type	1
I - CT rating	5 A
I - Number of CTs	I1, I2, I3
I - Rated current (I _n)	630 A
I - Base current (I _b)	630 A
I0 - Residual current	None
I'0 - Residual current	None
I' - CT rating	5 A
I' - Number of CTs	I1, I2, I3
I' - Rated current (I' _n)	630 A (except C86: I' _n = 5 A)
I' - Base current (I' _b)	630 A
V - Number of VTs	V1, V2, V3
V - Rated primary voltage (U _{np})	20 kV
V - Rated secondary voltage (U _{ns})	100 V
V0	3V sum
Vnt	None
V' - Number of VTs	V'1, V'2, V'3 (B83) U'21 (B80)
V' - Rated primary voltage (U' _{np})	20 kV
V' - Rated secondary voltage (U' _{ns})	100 V
V'0	3V sum
Particular characteristics	
Transformer present	T87, G88, M88: yes Other applications: no
Rated voltage Un1	20 kV
Rated voltage Un2	20 kV
Rated power	30 MVA
Vector shift	0
Rated speed	3000 rpm
Zero speed threshold	5 %
Pulses per rotation	1
Number of capacitor steps	1
Type of connection	Star
Capacitor step ratio	1,1,1,1

SFT2841 setting and operating software

Default settings

Parameter	Default value
Control logic	
Switchgear control	On, circuit breaker
Logic discrimination	Off
Genset shutdown	Off
De-excitation	Off
Load shedding	Off
Restart	Off
Capacitor step control	Off
Automatic transfer	Off
Logic I/O assignment	
O1, O3	On, NO, permanent
O2, O5	On, NC, permanent
O4	Off
Protection	
Activity	All protection functions are "off"
Latching	21B, 27D, 32P, 32Q, 38/49T, 40, 46, 48/51LR, 49RMS, 50BF, 50/27, 50/51, 50N/51N, 50V/51V, 51C, 64REF, 67, 67N, 78PS, 87M, 87T
Participation in switchgear control	21B, 32P, 32Q, 37, 38/49T, 40, 46, 48/51LR, 49RMS, 50/27, 50/51, 50N/51N, 50V/51V, 64REF, 67, 67N, 78PS, 87M, 87T
Genset shutdown	12, 40, 50/51 (units 6, 7), 50N/51N (units 6, 7), 59N, 64REF, 67, 67N, 87M, 87T
De-excitation	12, 40, 50/51 (units 6, 7), 50N/51N (units 6, 7), 59, 59N, 64REF, 67, 67N, 87M, 87T
Setting	Approximate values consistent with general characteristics by default
Matrix	
LED	According to front panel marking
Disturbance recording	Pick-up All protection functions except for 14, 27R, 38/49T, 48/51LR, 49RMS, 50BF, 51C, 66
Logic outputs	O1: tripping O2: inhibit closing O3: closing O5: watchdog
Disturbance recording	
Activity	On
Number of recordings	6
Duration of a recording	3
Number of samples per period	12
Number of Pretrig periods	36

SFT2841 setting and operating software

Configuration of a Sepam network

Connection window

The SFT2841 software connection window is used:

- To select an existing Sepam network or configure a new one
- To set up the connection to the selected Sepam network
- To select one Sepam unit from the network and access its parameters, settings, and operation and maintenance information.

Configuration of a Sepam network

Several configurations can be defined for the various Sepam installations.

A Sepam network configuration is identified by a name. It is saved on the SFT2841 PC in a file in the SFT2841 installation directory (default: C:\Program Files\Schneider\SFT2841\Net).

Configuration of a Sepam network is in 2 parts:

- Configuration of the communication network
- Configuration of the Sepam units.

Configuration of the communication network

To configure the communication network, first define:

- The type of link between the PC and the Sepam network
- The communication parameters, according to the type of link selected:
 - direct serial link
 - link via Ethernet TCP/IP
 - link via telephone modem.

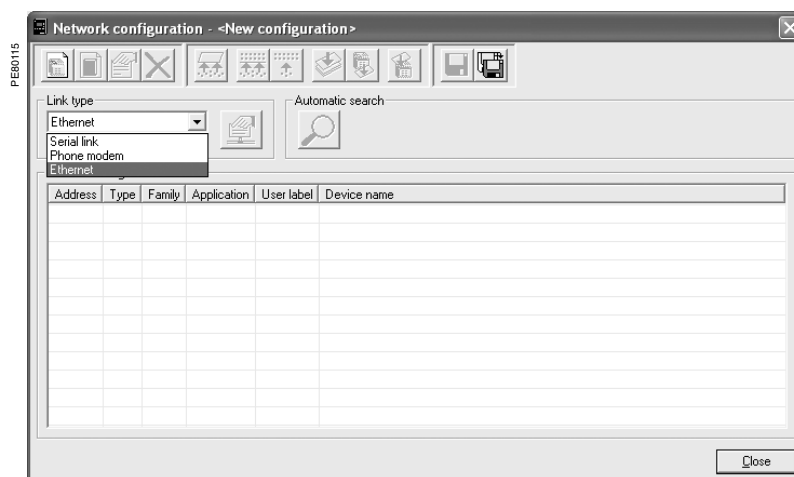

Configuration windows for the communication network, according to the type of link: serial link, modem link (STN) or Ethernet link (TCP).

SFT2841 setting and operating software

Configuration of a Sepam network

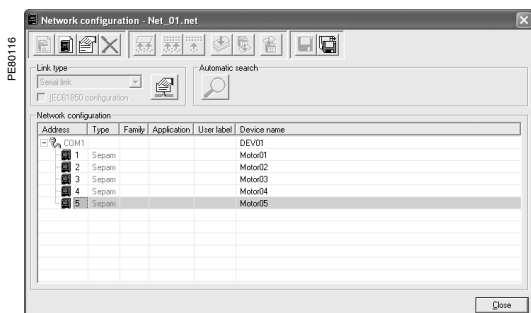

Configuration window for the serial link communication network.

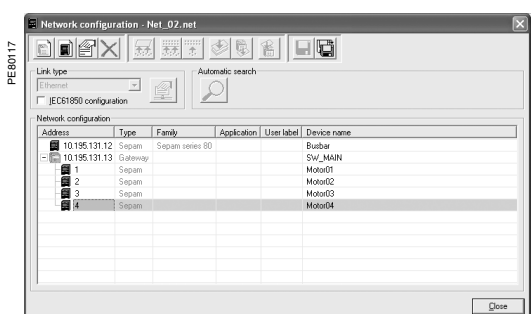

Configuration window for the Ethernet TCP/IP communication network.

Direct serial link

The Sepam units are connected to an RS 485 (or fiber-optic) multidrop network. Depending on the serial link interfaces available on the PC, the PC itself will be connected either directly to the RS 485 network (or fiber-optic HUB), or via an RS 232/RS 485 converter (or fiber-optic converter).

The communication parameters to be defined are:

- port: communication port used on the PC
- speed: 4800, 9600, 19200 or 38400 bauds
- parity: None, Even or Odd
- handshake: None, RTS or RTS-CTS
- time-out: from 100 to 3000 ms
- number of retries: from 1 to 6.

Link via Ethernet TCP/IP

The Sepam units are connected to an RS 485 multidrop network over one or more Ethernet Modbus TCP/IP gateways (for example: EGX gateways or ECI850 servers that act as the Modbus TCP/IP gateway for the link with the SFT2841).

Use on an IEC 61850 network

SFT2841 can be used on an IEC 61850 network. In this case, it can be used to define the IEC 61850 configuration of Sepams connected to this network. See the Sepam IEC 61850 Communication user's manual (reference SEPED306024EN) for more information.

Configuration of the Modbus TCP/IP gateway

See the setup manual for the gateway used.

In general, the gateway should be assigned an IP address.

The configuration parameters for the gateway's RS 485 interface must be defined in accordance with the Sepam communication interface configuration:

- speed: 4800, 9600, 19200 or 38400 bauds
- character format: 8 data bits + 1 stop bit + parity (none, even, odd).

Configuration of communication on SFT2841

When configuring a Sepam network on SFT2841, the following communication parameters must be defined:

- type of device: Modbus gateway, ECI850 or Sepam
- IP address: IP address for the connected remote equipment
- time-out: from 100 to 3000 ms.

A time-out of between 800 ms and 1000 ms is sufficient in most installations.

Communication via the TCP/IP gateway may, however, be slowed down if other applications want Modbus TCP/IP or IEC 61850 access at the same time.

The time-out value should then be increased (2 to 3 seconds).

- number of retries: from 1 to 6.

Note 1: SFT2841 uses the Modbus TCP/IP communication protocol.

Although communication is IP-based, use of SFT2841 is restricted to a local installation network based on an Ethernet network (LAN – Local Area Network).

The operation of SFT2841 over a WAN (Wide Area Network) cannot be guaranteed because of the presence of some routers or firewalls that may reject the Modbus protocol, causing communication times that would be incompatible with Sepam.

Note 2: SFT2841 allows Sepam protection settings to be modified, and direct activation of the outputs. These operations, which could involve the operation of electrical switchgear (opening and closing), and thus risk the safety of people and installations, are protected by the Sepam password. In addition to this protection, the E-LANs and S-LANs must be designed as private networks, protected from external actions by all suitable methods.

SFT2841 setting and operating software

Configuration of a Sepam network

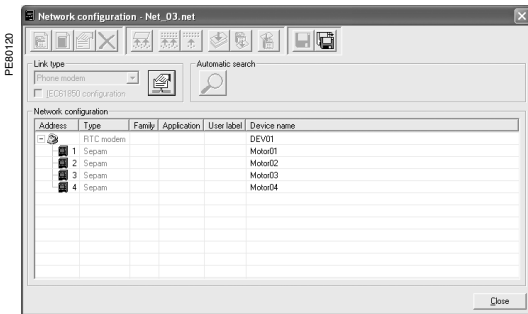

Configuration window for the communication network via telephone modem.

Link via telephone modem

The Sepam units are connected to an RS 485 multidrop network using an industrial STN modem.

This modem is the called modem. It must first be configured, either via AT commands from a PC using HyperTerminal or the configuration tool that may have been supplied with the modem, or by setting switches (see the modem manufacturer's manual).

The PC may use an internal or an external modem. This modem on the PC side is always the calling modem. It must be installed and configured in accordance with the Windows modem installation procedure.

Configuration of the calling modem in SFT2841

When configuring a Sepam network, SFT2841 displays the list of all the modems installed on the PC.

The communication parameters to be defined are:

- modem: select one of the modems listed by SFT2841
- telephone no.: no. of the remote modem to be called
- speed: 4800, 9600, 19200 or 38400 bauds
- parity: none (not adjustable)
- handshake: none, RTS or RTS-CTS
- time-out: from 100 to 3000 ms.

Communication via modem and telephone network is slowed considerably because of the transit time through the modems. A time-out of between 800 ms and 1000 ms is sufficient in most 38400 baud installations. In some cases, the poor quality of the telephone network may require a slower speed (9600 or 4800 bauds). The time-out value should then be increased (2 to 3 seconds).

- number of retries: from 1 to 6.

Note: the speed and parity of the calling modem must be configured under Windows with the same values as for SFT2841.

SFT2841 setting and operating software

Configuration of a Sepam network

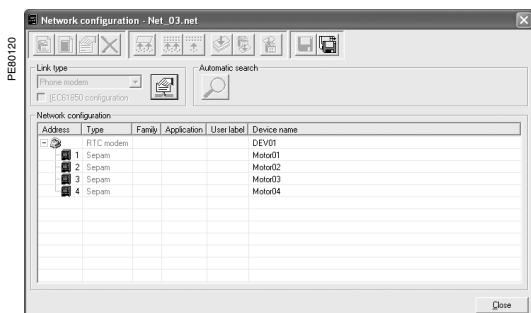

Configuration window for the communication network via telephone modem.

Configuration of called modem

The modem on the Sepam side is the called modem. It must first be configured, either via AT commands from a PC using HyperTerminal or the configuration tool that may have been supplied with the modem, or by setting switches (see the modem manufacturer's manual).

Modem RS 485 interface

In general, the configuration parameters for the modem's RS 485 interface must be defined in accordance with the Sepam communication interface configuration:

- speed: 4800, 9600, 19200 or 38400 bauds
- character format: 8 data bits + 1 stop bit + parity (none, even, odd).

Telephone network interface

Modern modems offer sophisticated features such as checking the quality of the telephone line, error correction and data compression. These options are not appropriate for communication between SFT2841 and Sepam, which is based on the Modbus RTU protocol. Their effect on communication performance may be the opposite of the expected result.

It is therefore highly advisable to:

- Invalidate the error correction, data compression and telephone line quality monitoring options
- Use the same end-to-end communication speed between:
 - the Sepam network and the called modem
 - the called modem (Sepam side) and the calling modem (PC side)
 - the PC and the calling modem (see recommended configurations table).

Sepam network	Telephone network	PC modem interface
38400 bauds	V34 modulation, 33600 bauds	38400 bauds
19200 bauds	V34 modulation, 19200 bauds	19200 bauds
9600 bauds	V32 modulation, 9600 bauds	9600 bauds

Industrial configuration profile

The following table shows the main characteristics of the modem on the Sepam side. These characteristics match a configuration profile commonly known as an "industrial profile", as opposed to the configuration of modems used in offices.

Depending on the type of modem used, the configuration will either be via AT commands from a PC using HyperTerminal or the configuration tool that may have been supplied with the modem, or by setting switches (see the modem manufacturer's manual).

Characteristics of the "industrial profile" configuration	AT command
Transmission in buffered mode, without error correction	\N0 (force &Q6)
Data compression deactivated	%C0
Line quality monitoring deactivated	%E0
DTR signal assumed to be permanently off (allows the modem connection to be established automatically on an incoming call)	&D0
CD signal off when carrier is present	&C1
All reports made to Sepam blocked	Q1
Character echo suppression	E0
No flow control	&K0

SFT2841 setting and operating software

Configuration of a Sepam network

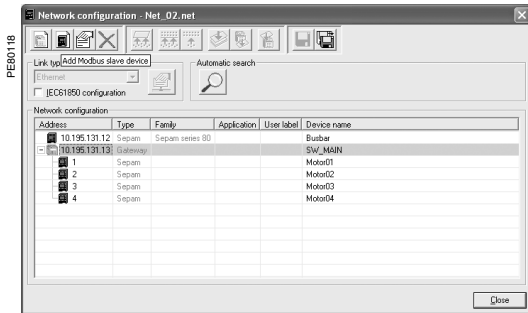

Sepam network connected to SFT2841.

Identification of Sepam units connected to the communication network

The Sepam units connected to the communication network are identified by either:

- Their Modbus address
- Their IP address
- The IP address for their gateway and their Modbus address

These addresses can be configured in either of the following ways:

- Manually, one by one:
 - the "Add" button is used to define a new device
 - the "Edit" button is used to modify the Modbus address if necessary
 - the "Delete" button removes a device from the configuration
- Or automatically for Modbus addresses, by running an automatic search of the Sepam units connected:
 - the "Automatic search"/"Stop search" button starts or interrupts the search
 - when SFT2841 recognizes a Sepam unit, its Modbus address and type are shown on screen
 - when a Modbus device other than Sepam responds to SFT2841, its Modbus address is displayed. The text "???" indicates that the device is not a Sepam.

The Sepam network configuration is saved in a file when the UMI window closes, by pressing the "OK" button.

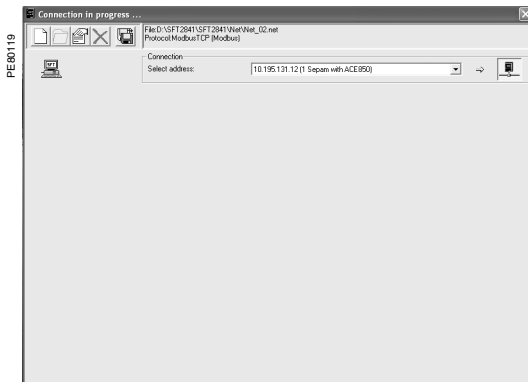





Access to parameters and settings for a Sepam series 80 connected to a communication network.

Access to Sepam information

To establish communication between SFT2841 and a Sepam network, select the Sepam network configuration you want, select the device connected to the TCP/IP network and press "Connect".

The Sepam network is displayed in the connection window. SFT2841 polls all the equipment defined in the selected configuration. Each Sepam queried is represented by an icon:

-  Sepam series 20 or Sepam series 40 actually connected to the network
-  Sepam series 80 actually connected to the network
-  Sepam configured but not connected to the network
-  Device other than Sepam connected to the network.

A summary report of each Sepam detected as present is also displayed:

- Sepam Modbus address
- Type of application and Sepam identification
- Any alarms present
- Any minor/major faults present.

To access parameters, settings and operation and maintenance information for a particular Sepam, click on the icon for that Sepam. SFT2841 then establishes a point-to-point connection with the selected Sepam.

SFT2841 software

Mimic-diagram editor

Presentation

Description

SFT2841 Sepam setting and operating software includes a mimic-diagram editor that can be used to personalize the mimic diagram for local control on the mimic-based UMI of Sepam series 80 units.

A mimic-diagram or single-line diagram is a simplified diagram of an electrical installation. It is made up of a fixed background on which symbols and measurements are placed.

The mimic-diagram editor can be used to:

- create a fixed, bitmap background (128 x 240 pixels) using standard drawing software
- create animated symbols or use predefined animated symbols to represent the electrotechnical devices or other objects
- assign the logic inputs or internal status conditions that modify the animated symbols. For example, the logic inputs for the circuit-breaker position must be assigned to the circuit-breaker symbol to enable the display of the open and closed conditions
- assign the logic outputs or internal status conditions that are activated when an opening or closing order are issued for the symbol
- display the current, voltage and power measurements on the mimic diagram.

Mimic-diagram and symbols

The symbols making up the mimic-diagram constitute the interface between the mimic-based UMI and the other Sepam control functions.

There are three types of symbols:

- Fixed symbol: represents the electrotechnical devices that are neither animated or controlled, e.g. a transformer
- Animated symbol with one or two inputs: represents the electrotechnical devices that change on the mimic diagram, depending on the symbol inputs, but cannot be controlled via the Sepam mimic-based UMI. This type of symbol is used for switch-disconnectors without remote control, for example.

- Controlled symbol with one or two inputs/outputs: represents the electrotechnical devices that change on the mimic diagram, depending on the symbol inputs, and can be controlled via the Sepam mimic-based UMI.

This type of symbol is used for circuit breakers, for example.

The symbol outputs are used to control the electrotechnical device:

- directly via the Sepam logic outputs
- by the switchgear control function
- by logic equations or the Logipam program.

Local control using a symbol

"Controlled - 1 input/output" and "Controlled - 2 inputs/outputs" symbols are used to control the switchgear corresponding to the symbol via the Sepam mimic-based UMI.

Control symbols with two outputs

"Controlled - 2 inputs/outputs" symbols have two control outputs for opening and closing of the symbolized device.

An order on the mimic-based UMI sends a 300 ms pulse on the controlled output.

Control symbols with one output

"Controlled - 1 input/output" symbols have one control output. The output remains in the last state to which it was ordered.

A new order results in a change in the output state.

Inhibition of orders

"Controlled - 1 input/output" and "Controlled - 2 inputs/outputs" symbols have two inhibition inputs that, when set to 1, block opening and closing orders. This makes it possible to create interlocking systems or other order-disabling systems that are taken into account by the UMI.

SFT2841 software

Mimic-diagram editor

Presentation

Symbol animation

Depending on the value of their inputs, symbols change. A graphic representation corresponds to each state. Animation is carried out automatically by changing the symbol each time the state changes.

The symbol inputs must be assigned directly to the Sepam inputs indicating the position of the symbolized switchgear.





Animated symbols with two inputs

"Animated - 2 inputs" and "Controlled - 2 inputs/outputs" symbols are animated symbols with two inputs, one open and the other closed.

This is the most common situation in representing switchgear positions.

The symbol has three states, i.e. three graphic representations: open, closed and unknown.

The latter is obtained when the inputs are not matched, in which case it is impossible to determine the position of the switchgear.



Symbol inputs	Symbol state	Graphic representation (example)
Input 1 (open) = 1 Input 2 (closed) = 0	Open	
Input 1 (open) = 0 Input 2 (closed) = 1	Closed	
Input 1 (open) = 0 Input 2 (closed) = 0	Unknown	
Input 1 (open) = 1 Input 2 (closed) = 1	Unknown	

Animated symbols with one input

"Animated -1 input" and "Controlled -1 input/output" symbols are animated symbols with one input. The value of the input determines the state of the symbol:

- input set to 0 = inactive
- input set to 1 = active

This type of symbol is used for simple presentation of information, for example the racked out position of a circuit breaker.

Symbol inputs	Symbol state	Graphic representation (example)
Input = 0	Inactive	
Input = 1	Active	

Symbol inputs/outputs

Depending on the desired operation of the mimic-based UMI, Sepam variables must be assigned to the inputs of animated symbols and the inputs/outputs of controlled symbols.

Sepam variables assigned to symbol inputs

Sepam variables	Name	Use
Logic inputs	Ixxx	Symbol animation directly based on device positions
Outputs of predefined functions	Switchgear control	V_CLOSE_INHIBITED
	Position of key on the front panel of Sepam	V_MIMIC_LOCAL, V_MIMIC_REMOTE, V_MIMIC_TEST
	Logic equations or Logipam program	V_MIMIC_IN_1 to V_MIMIC_IN_16

Sepam variables to be assigned to symbol outputs

Sepam variables	Name	Use
Logic outputs	Oxxx	Direct control of devices
Inputs of predefined functions	Switchgear control	V_MIMIC_CLOSE_CB V_MIMIC_OPEN_CB
	Logic equations or Logipam program	V_MIMIC_OUT1 to V_MIMIC_OUT16

SFT2841 software

Mimic-diagram editor

General screen organization





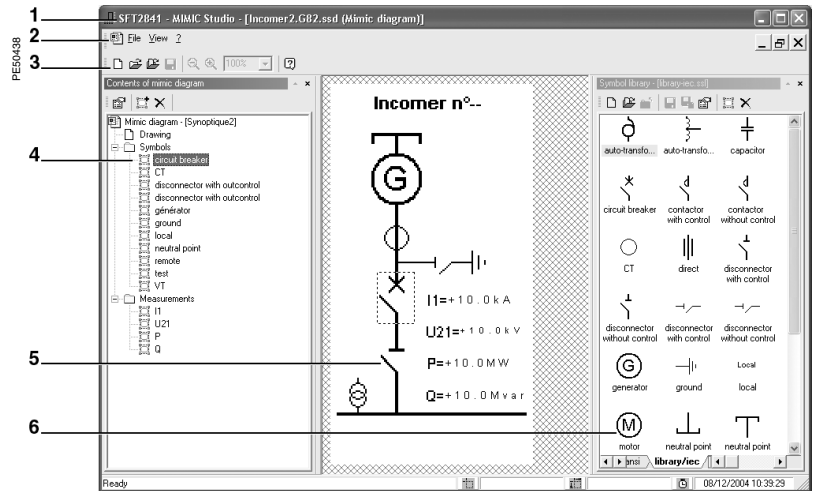

Main screen of the mimic-diagram editor

The main screen of the mimic-diagram editor is, by default, organized as presented below.

- 1 The title bar, with:
 - the name of the application
 - identification of the document
 - handles for window adjustments
- 2 The menu bar for access to all functions
- 3 The main toolbar, a group of contextual icons for quick access to the main functions
- 4 The mimic-diagram explorer, with the list of symbols and measurements in the current mimic diagram.
 - A toolbar specific to this zone.
- 5 A drawing zone showing the diagram displayed on the mimic-based UMI.
 - This is the work zone where the user can place symbols and measurements.
- 6 The symbol library containing the symbols used in the mimic diagram.
 - A toolbar specific to this zone.



Icons in the main toolbar

-  Select a new diagram in the library of existing diagrams
-  Open an existing diagram
-  Open a symbol library
-  Save a diagram
-  Zoom forward and back
-  200% Display the value of the zoom in %. The value of the zoom can also be entered directly
-  On-line help

SFT2841 software Mimic-diagram editor General screen organization

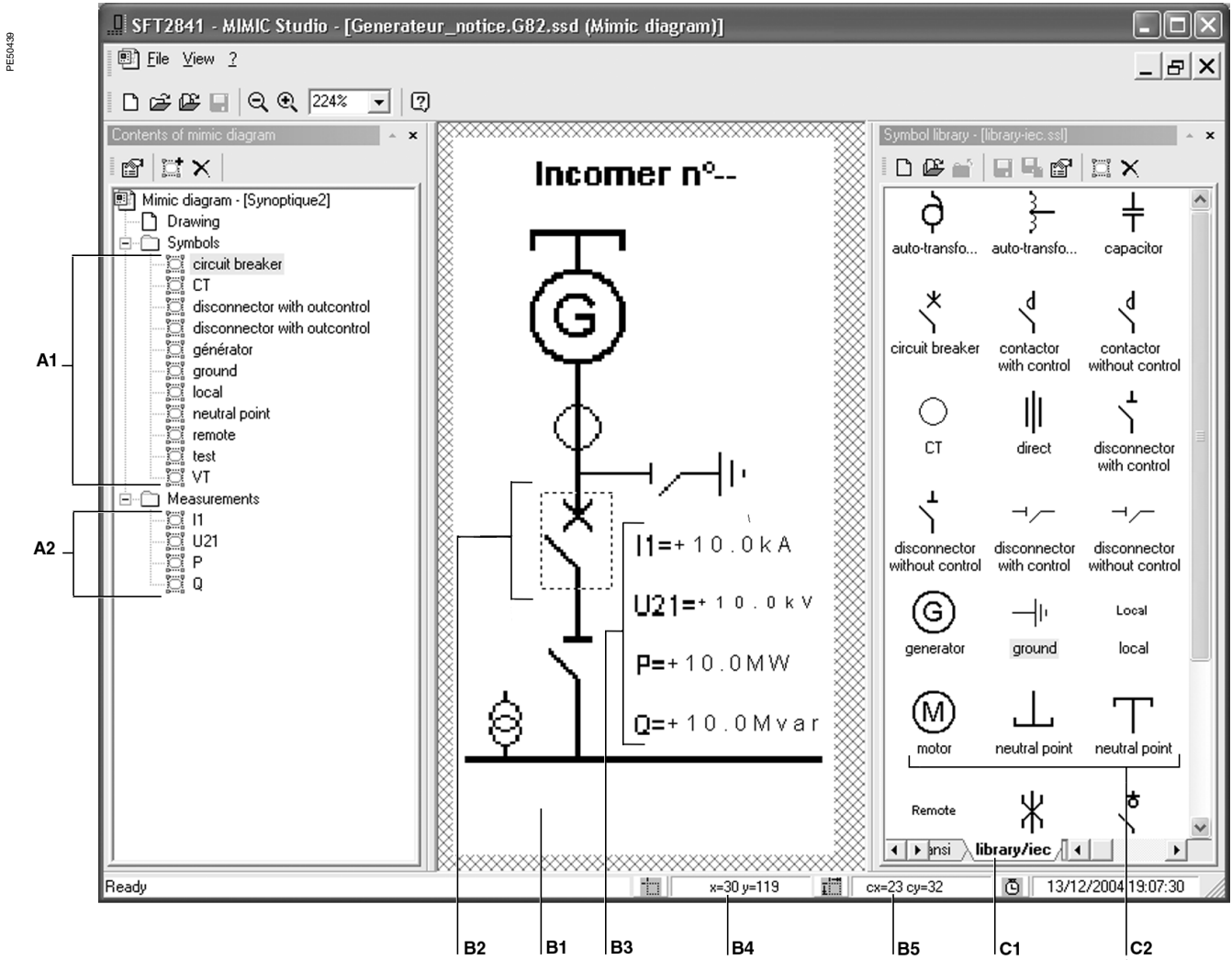

2

A1

A2

B2 B1 B3 B4 B5 C1 C2

Mimic-diagram explorer	Mimic-diagram editor	Symbol library
Description	Description	Description
A1 List of symbols contained in the mimic diagram	B1 Mimic diagram. Double-click the diagram to open the drawing software	C1 Tabs to select a symbol library
A2 List of measurements contained in the mimic diagram	B2 Symbol contained in the mimic diagram	C2 Symbols in the library
Double-click a symbol or measurement to open the "Symbol properties" window.	B3 Measurements contained in the mimic diagram	Double-click a symbol to open the "Symbol properties" window.
Icons in the toolbar	Double-click a symbol or measurement to open the "Symbol properties" window. Click and hold to move a symbol or a measurement in the diagram.	Icons in the toolbar
Read or modify diagram properties	B4 Coordinates of the selected symbol or measurement in pixels	Create a new symbol library
Copy a symbol from the library	B5 Dimensions of the selected symbol or measurement in pixels	Open a symbol library
Delete a symbol		Close a symbol library
		Save the symbol library to the same file or a different file
		Read or modify symbol-library properties
		Create a new symbol
		Delete a symbol

SFT2841 software

Mimic-diagram editor

Use

Use

The mimic-diagram editor can be used on three different levels, depending on the degree to which the diagram is personalized:

- simple use, e.g. to adapt a predefined diagram
- advanced use, e.g. to complete a predefined diagram
- expert use, e.g. to create a new diagram.

Simple use

This level is the least complicated and should be used first.

To adapt a predefined diagram, proceed as follows:

1. Select a predefined diagram template in the IEC or ANSI libraries.
2. Set up the diagram properties:
 - finish the diagram
 - assign the symbol inputs and outputs, if necessary
3. Save the diagram.
4. Quit the mimic-diagram editor.

Advanced use

To complete a predefined diagram, proceed as follows:

1. Select a predefined diagram template in the IEC or ANSI libraries.
2. Add an existing symbol or measurement to the diagram.
3. Set up the diagram properties:
 - finish the diagram
 - select the new measurements to be displayed
 - assign the symbol inputs and outputs, if necessary
4. Save the diagram.
5. Quit the mimic-diagram editor.

Expert use

Creation of a completely new diagram requires in-depth knowledge of all the functions offered by the mimic-diagram editor.

To create a new diagram, proceed as follows:

1. Create new symbols in the symbol library.
2. Set up the properties of the new symbols.
3. If applicable, create new diagram templates on the main window.
4. Create the new diagram:
 - add the symbols
 - add the measurements
 - draw the background of the diagram
5. Set up the diagram properties:
 - select the new measurements to be displayed
 - assign the symbol inputs and outputs, if necessary
6. Save the diagram.
7. Quit the mimic-diagram editor.

SFT2841 software

Mimic-diagram editor

Use

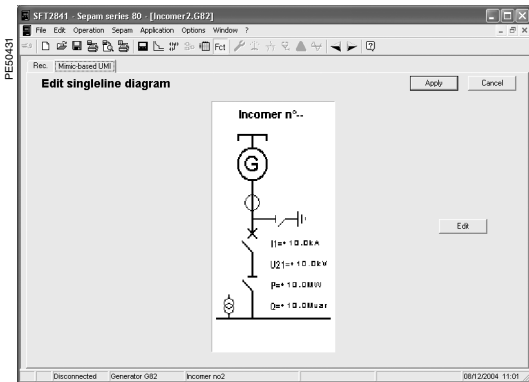

Access to the mimic-diagram editor.

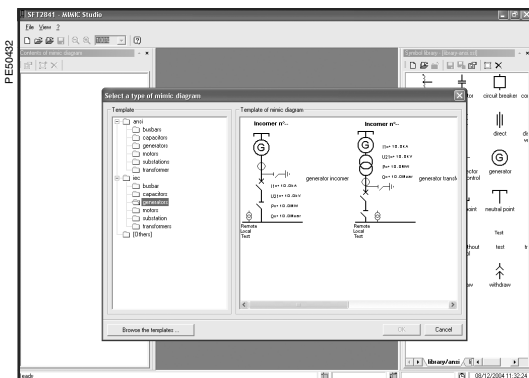

Selection of a predefined diagram template.

Run the mimic-diagram editor

The mimic-diagram editor can be accessed only if the Sepam series 80 was set up with a mimic-based UMI on the "Hardware set-up" screen in the SFT2841 software. The mimic-diagram editor of the SFT2841 software is accessed via the **[Fct]** icon and the "Mimic-based UMI" tab.

Click the [Edit] button to run the mimic-diagram editor. Simply close or reduce the mimic-diagram editor to return to the setting and operating screens in the SFT2841 software.

When the mimic-diagram editor is run:

- if a diagram is already linked to the Sepam, the editor displays the diagram
- if a diagram is not linked to the Sepam, a window opens for selection of a predefined diagram template in one of the two diagram libraries supplied:
 - diagrams complying with standard IEC 60617
 - diagrams complying with standard ANSI Y32.2-1975.

Select a predefined diagram template

The window used to select a predefined diagram template is displayed:

- when the mimic-diagram editor is opened for the first time
- when the File/New command is clicked
- when the **[Fct]** icon is clicked.

Two libraries of predefined diagrams are supplied:

- diagrams complying with standard IEC 60617
- diagrams complying with standard ANSI Y32.2-1975.

For each Sepam application, each library contains a number of predefined diagram templates corresponding to the most frequently encountered single-line diagrams.

Other diagram templates can be managed by clicking the [Browse the templates] button.

To see the available diagrams, select a subcategory (e.g. substations).

A number of diagrams are then displayed in the "Template of mimic diagram" window.

To select a diagram template, click the drawing and immediately confirm by clicking [OK].

SFT2841 software

Mimic-diagram editor

Use

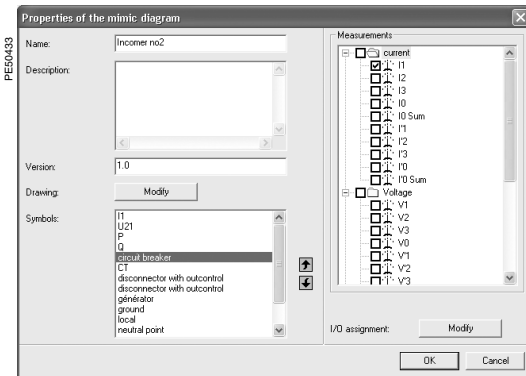

Personalization of diagram properties.

Set up the diagram properties

Operation of a mimic-diagram can be completely personalized.

The  icon in the toolbar of the diagram explorer provides access to the "Properties of the mimic diagram" window.

Personalization of diagram properties is broken down into four operations:

1. Indication of the general diagram properties: diagram name, description and version.
2. Modifications in the diagram.
3. Checks on the measurements displayed in the predefined fields based on the list of values measured by Sepam.
4. Assignment of inputs/outputs to the animated/controlled symbols making up the diagram.

Modifications in the diagram

Click the [Modify] button for the drawing to run the drawing software on the PC (MS Paint by default). The background is displayed, without the symbols or the fields reserved for the measurements.

The drawing software can be used to rework the diagram, e.g. by adding text or modifying the title.

Check on diagram measurements

Each "Measurement" symbol in the diagram is linked by default to the corresponding Sepam measurement.

For example, the "I1" symbol is linked to the value of current I1, the phase 1 current measured by Sepam.

It is possible to display additional measurement values that can be selected in the "Measurements" list.

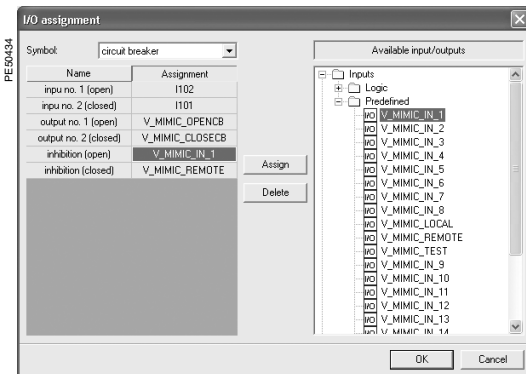

Logic input/output assignment.

Logic input/output assignment

The [Modify] button for input/output assignment opens the "I/O assignment" window used to check and modify the Sepam variables assigned to each input and output of each symbol.

Proceed as follows to modify the symbol inputs and outputs in a mimic-diagram:

1. Select a symbol.
2. Select an input to be modified, if applicable.
3. Select the desired Sepam input variable among the available inputs (it is not possible to assign a Sepam output variable to a symbol input)
 - click the [Assign] button to link the Sepam variable to the symbol input
 - click the [Delete] button to release the symbol input.
4. Proceed in the same manner to modify the assignment of a symbol output, if applicable.
5. Confirm the modifications by clicking [OK].
6. Select the next symbol and proceed in the same manner.

Modify the background of the diagram

The background is the drawing, without the symbols or the fields reserved for the measurements.

The background can be modified using the drawing software on the PC (MS Paint by default):

- to add text or modify the title of the diagram
- to add descriptions for new measurements
- to complete the single-line diagram and add new symbols to the diagram.

The drawing software can be run:

- via the "Diagram properties" window
- by double-clicking the diagram on the main editor window.

It is necessary to save the new drawing and quit the drawing software before returning to the mimic-diagram editor.

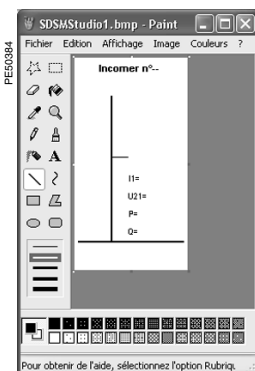

Drawing of the background of the diagram.

SFT2841 software

Mimic-diagram editor

Use

Add an existing symbol to the diagram

Proceed as follows to add an existing symbol to a diagram:

1. Select an existing symbol in one of the symbol libraries.
 2. Add the symbol to those already in the diagram by clicking the  icon in the diagram explorer.
- The new symbol is displayed in the upper left-hand corner of the diagram.
3. Modify the drawing by adding the graphic elements required to connect the new symbol in the mimic-diagram.
 4. Correctly position the new symbol in the diagram:
 - select the new symbol with a click on the left mouse button
 - hold and drag the symbol to the desired position in the diagram.
 To precisely position the symbol, it is possible to indicate the desired coordinates:
 - open the "Symbol properties" window
 - modify the symbol coordinates (X, Y) in the "Specific" zone
 - confirm the new position by clicking [OK].
 5. Test the animation of the new symbol:
 - open the "Symbol properties" window
 - modify symbol state: modify the data in the "VALUE" field in the "Specific" zone
 - confirm the new state by clicking [OK] and check the new graphic representation of the symbol in the diagram.

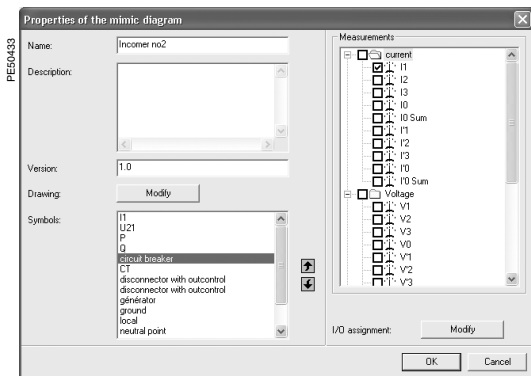

Personalization of diagram properties.

Add a measurement to a diagram

The following measurements can be shown on a diagram:

- current: I1, I2, I3, I'1, I'2, I'3, I0, I0Σ, I'0, I'0Σ
- voltage: V1, V2, V3, V0, U21, U32, U13, V'1, V'2, V'3, V'0, U'21, U'32, U'13
- power: P, Q, S, Cos φ.

Proceed as follows to add a measurement to a diagram:

1. Display diagram properties by clicking the  icon in the diagram explorer.
2. In the "Measurements" list, click the box for the measurement to be added and confirm by clicking [OK].
3. The new measurement is displayed in the upper left-hand corner of the diagram. modify the drawing by adding the description of the new measurement, e.g. "I0 =".
4. Correctly position the new measurement in the diagram:
 - select the new measurement with a click on the left mouse button
 - hold and drag the measurement to the desired position in the diagram.
 To precisely position the new measurement, it is possible to indicate the desired coordinates:
 - open the "Symbol properties" window
 - modify the measurement coordinates (X, Y) in the "Specific" zone
 - confirm the new position by clicking [OK].
5. Modify the display size of the new measurement:
 - open the "Symbol properties" window
 - modify the display size of the measurement by changing the value in the "Size" field in the "Specific" zone
 - confirm the new size by clicking [OK] and check the new graphic representation of the measurement in the diagram.

Delete a symbol or measurement in the diagram

Proceed as follows to delete a symbol or measurement in the diagram:

1. Select the symbol or measurement to be deleted in the diagram explorer.
2. Delete the symbol or the measurement by clicking the  icon in the diagram explorer.

SFT2841 software Mimic-diagram editor Use

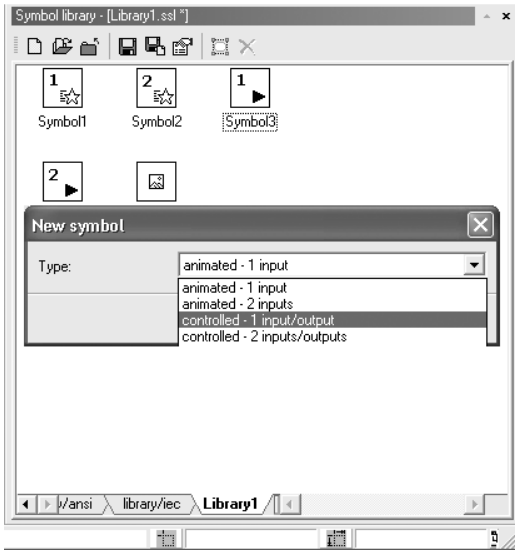

Creation of new symbols.

Create a new symbol

Two libraries of predefined diagrams are supplied in the "Symbol library" window:

- a set of diagrams complying with the IEC standard
- a set of diagrams complying with the ANSI standard.

It is not possible to create new symbols in the two libraries. Each symbol is represented by an icon.

Proceed as follows to create a new symbol:

1. Create a new library by clicking the icon or select a previously created library.
2. Create a symbol in the library by clicking the icon.
3. Select the type of symbol in the "New symbol" window among the five types of symbols available.

The five types are presented in the section below.

The symbol is displayed in the library with a default icon.

4. Set up the symbol properties by double-clicking the symbol. The "Symbol properties" window is displayed to personalize the graphic representation of the symbol and assign the inputs and outputs.

See the section on "Definition of symbol properties".

Five types of symbols

Symbol type	Default icon	Inputs	Example of IEC symbol	Outputs
Animated - 1 input		Active		
Animated - 2 inputs		Open Closed		
Controlled - 1 input/output		Active Inhibition (active) Inhibition (inactive)		Active
Controlled - 2 inputs/outputs		Open Closed Inhibition (open) Inhibition (closed)		Open Close
Fixed				

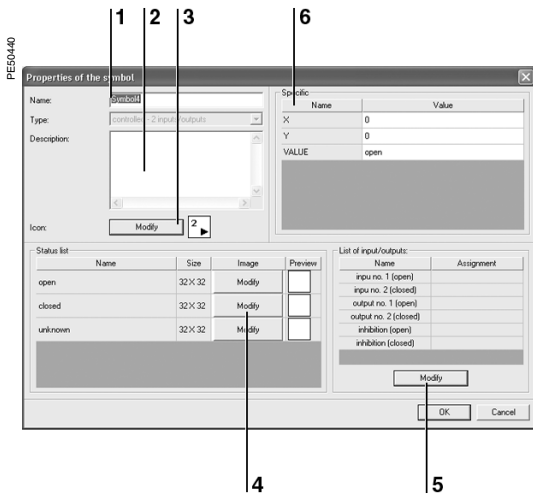

Definition of symbol properties:

- 1 Symbol name
- 2 Symbol description
- 3 Modify the icon
- 4 Modify the graphic representations of symbol states
- 5 Modify input/output assignments
- 6 Position and test the symbol in the diagram

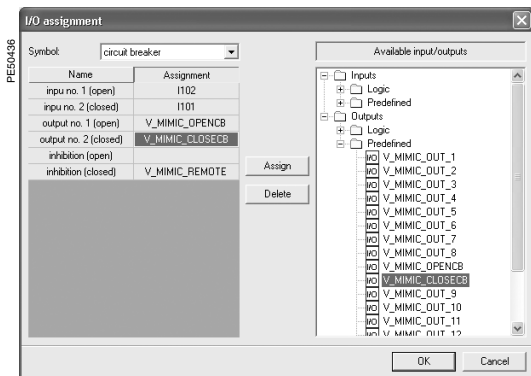

Input/output assignment.

Set up the symbol properties

The properties of a symbol can be personalized in the "Symbol properties" window.

Personalization of symbol properties is broken down into four operations:

1. Indication of the general symbol properties: name and description.
2. Modification of the symbol icon.
3. Modification of the graphic representations of symbol states.
4. Assignment of the inputs/outputs linked to the symbol.

Modify the symbol icon

The icon represents the symbol in the library of symbols.

Click the [Modify] button "3" to run the drawing software. The icon is displayed and can be modified as desired, as long as the format (32 x 32 pixels) is maintained.

It is necessary to save the new icon and quit the drawing software before going on to the next step.

Modify the graphic representations of symbol states

The animated or controlled symbols are represented in the diagram in two or three different states.

A graphic representation corresponds to each state.

Click the [Modify] button "4" to run the drawing software. The graphic representation of a symbol state is displayed and can be freely modified.

It is necessary to save the new representation and quit the drawing software before going on to the next step.

Assign the inputs/outputs linked to the symbol.

The [Modify] button "5" opens the "I/O assignment" window used to assign a Sepam variable to each input and output of the symbol.

Proceed as follows to assign a symbol input:

1. Select a symbol input.
2. Select a Sepam input variable among the available inputs (it is not possible to assign a Sepam output variable to a symbol input).
3. Click the [Assign] button to link the Sepam variable to the symbol input.

Proceed in the same manner to assign a symbol output.

Create a new predefined diagram template

A personalized mimic-diagram can be saved as a template for later use, similar to the predefined diagram templates in the IEC and ANSI diagram libraries.

Proceed as follows to save a personalized diagram as a diagram template:

1. Select the command File / Save as...
2. Open the directory \SDSMStudio\Template.
3. If necessary, create a personalized directory in addition to the existing \IEC and \ANSI directories.
4. Indicate the name of the diagram file with the .sst extension.
5. Set the type of file as "Document template (*.sst)".
6. Save the mimic diagram.

When the mimic-diagram editor is run, the new predefined diagram templates are proposed in the personalized directory or in the "Others" directory.

Principles	114
Methods	115
Testing and metering equipment required	116
General examination and preliminary actions	117
Checking of phase current and voltage input connections	118
With 3-phase generator	118
With single-phase generator and voltages delivered by 3 VTs	120
With single-phase generator and voltages delivered by 2 VTs	121
Checking of phase current input connections	122
For differential applications	122
LPCT type current sensors	123
Checking of residual current and residual voltage input connections	124
Checking of residual current input connection	125
Checking of residual voltage input connection	126
With voltage delivered by 3 VTs in open delta arrangement	126
With voltage delivered by 1 neutral point VT	127
Checking of Sepam B80 additional voltage input connection	128
Checking of Sepam B83 additional phase voltage input connections	130
Checking of Sepam B83 additional residual voltage input connection	132
Checking of Sepam C86 unbalance current input connections	133
Checking of logic input and output connections	134
Checking of optional module connections	135
Validation of the complete protection chain	136
Test sheet	137
Sepam series 80	137

⚠ DANGER**HAZARD OF ELECTRIC SHOCK, ELECTRIC ARC OR BURNS**

- Only qualified personnel should commission this equipment. Such work should be performed only after reading this entire set of instructions.
- NEVER work alone.
- Obey all existing safety instructions when commissioning and maintaining high-voltage equipment.
- Beware of potential hazards and wear personal protective equipment.

Failure to follow these instructions will result in death or serious injury.

Protection relay testing

Protection relays are tested prior to commissioning, with the dual aim of maximizing availability and minimizing the risk of malfunctioning of the assembly being commissioned. The problem consists of defining the consistency of the appropriate tests, keeping in mind that the relay is always involved as the main link in the protection chain.

Therefore, protection relays based on electromechanical and static technologies, the performances of which are not totally reproducible, must be systematically submitted to detailed testing, not only to qualify relay commissioning, but also to check that they actually are in good operating order and maintain the required level of performance.

The Sepam concept makes it possible to do away with such testing, since:

- the use of digital technology guarantees the reproducibility of the performances announced
- each of the Sepam functions has undergone full factory-qualification
- an internal self-testing system provides continuous information on the state of the electronic components and the integrity of the functions (e.g. automatic tests diagnose the level of component polarization voltages, the continuity of the analog value acquisition chain, non-alteration of RAM memory, absence of settings outside the tolerance range) and thereby guarantees a high level of availability

Sepam is therefore ready to operate without requiring any additional qualification testing that concerns it directly.

Sepam commissioning tests

The preliminary Sepam commissioning tests may be limited to a commissioning check, i.e.:

- checking of compliance with BOMs and hardware installation diagrams and rules during a preliminary general check
- checking of the compliance of the general settings and protection settings entered with the setting sheets
- checking of current or voltage input connections by secondary injection tests
- checking of logic input and output connections by simulation of input data and forcing of output status
- validation of the complete protection chain (possible customized logical functions included)
- checking of the connection of the optional MET148-2, MSA141 and MSC025 modules.

The various checks are described on the next page.

General principles

■ All the tests should be carried out with the MV cubicle completely isolated and the MV circuit breaker racked out (disconnected and open)

■ All the tests are to be performed in the operating situation: no wiring or setting changes, even temporary changes to facilitate testing, are allowed.

The SFT2841 parameter setting and operating software is the basic tool for all Sepam users. It is especially useful during Sepam commissioning tests. The tests described in this document are systematically based on the use of that tool.

For each Sepam:

■ only carry out the checks suited to the hardware configuration and the functions activated

(A comprehensive description of all the tests is given further on)

■ use the test sheet provided to record the results of the commissioning tests.

Checking of current and voltage input connections

The secondary injection tests to be carried out to check the connection of the current and voltage inputs are described according to:

■ the type of current and voltage sensors connected to Sepam, in particular for residual current and voltage measurement

■ the type of injection generator used for the tests: three-phase or single-phase generator

■ the type of Sepam.

The different possible tests are described further on by:

■ a detailed test procedure

■ the connection diagram of the associated test generator.

Determination of checks to be carried out

The table below indicates the page on which the following are described:

■ general tests to be performed according to the type of measurement sensors and type of generator used

■ additional tests to be performed for certain types of Sepam, with a single or three-phase generator

General tests			
Current sensors	Voltage sensors	Three-phase generator	Single-phase generator
3 CTs or 3 LPCTs	3 VTs	page 118	page 120
3 CTs or 3 LPCTs	3 VTs	page 118	page 120
1 or 2 core bal. CTs		page 125	page 125
3 CTs or 3 LPCTs	3 VTs	page 118	page 120
	3 V0 VTs	page 126	page 126
3 CTs or 3 LPCTs	3 VTs	page 118	page 120
1 or 2 core bal. CTs	3 V0 VTs	page 124	page 124
3 CTs or 3 LPCTs	2 phase VTs	page 119	page 121
	3 V0 VTs	page 126	page 126
3 CTs or 3 LPCTs	2 phase VTs	page 119	page 121
1 or 2 core balance CTs	3 V0 VTs	page 124	page 124
3 CTs or 3 LPCTs	3 VTs	page 118	page 120
	1 neutral point VT	page 127	page 127
3 CTs or 3 LPCTs	3 VTs	page 118	page 120
1 or 2 core bal. CTs	1 neutral point VT	pages 125 and 127	pages 125 and 127
3 CTs or 3 LPCTs	2 phase VTs	page 119	page 121
	1 neutral point VT	page 127	page 127
3 CTs or 3 LPCTs	2 phase VTs	page 119	page 121
1 or 2 core bal. CTs	1 neutral point VT	pages 125 and 127	pages 125 and 127
Additional tests			
Type of Sepam	Type of test		
T87, M87, M88, G87, G88	Checking of phase current input connections for differential application	page 122	
B80	Checking of additional phase voltage input connection	page 128	
B83	Checking of additional phase voltage input connections	page 130	
B83	Checking of additional residual voltage input connection	page 130	
C86	Checking of unbalance current input connections	page 133	

Generators

- dual sinusoidal AC current and voltage generator:
 - 50 or 60 Hz frequency (according to the country)
 - current adjustable up to at least 5 A rms
 - adjustable up to the rated secondary phase-to-phase voltage of the VTs
 - adjustable relative phase displacement (V, I)
 - three-phase or single-phase type
- DC voltage generator:
 - adjustable from 48 to 250 V DC, for adaptation to the voltage level of the logic input being tested.

Accessories

- plug with cord to match the "current" test terminal box installed
- plug with cord to match the "voltage" test terminal box installed
- electric cord with clamps, wire grip or touch probes.

Metering devices (built into the generator or separate)

- 1 ammeter, 0 to 5 A rms
- 1 voltmeter, 0 to 230 V rms
- 1 phasemeter (if phase displacement (V, I) is not identified on the voltage and current generator).

Computer equipment

- PC with minimal configuration:
 - Microsoft Windows XP or Vista
 - 400 MHz Pentium processor
 - 64 MB of RAM
 - 200 MB free on hard disk
 - CD-ROM drive
- SFT2841 software
- CCA783 serial connection cord between the PC and Sepam.

Documents

- complete connection diagram of Sepam and additional modules, with:
 - phase current input connections to the corresponding CTs via the test terminal box
 - residual current input connection
 - phase voltage input connections to the corresponding VTs via the test terminal box
 - residual voltage input connection to the corresponding VTs via the test terminal box
 - logic input and output connections
 - temperature sensor connections
 - analog output connection
 - connection of the synchro-check module
- hardware BOMs and installation rules
- group of Sepam parameter and protection settings, available in paper format.

Checking to be done prior to energizing

Apart from the mechanical state of the equipment, use the diagrams and BOMs provided by the contractor to check:

- identification of Sepam and accessories determined by the contractor
- correct earthing of Sepam (via terminal 13 of the 20-pin connector (E) and the functional earthing terminal located on the back of the Sepam unit)
- correct connection of auxiliary voltage (terminal 1: positive polarity; terminal 2: negative polarity)
- presence of the DPC (detection of plugged connectors) bridge on terminals 19-20 of the 20-pin connector (E).
- presence of a residual current measurement core balance CT and/or additional modules connected to Sepam, when applicable
- presence of test terminal boxes upstream from the current inputs and voltage inputs
- conformity of connections between Sepam terminals and the test terminal boxes.

Connections

Check that the connections are tightened (with equipment non-energized).

The Sepam connectors must be correctly plugged in and locked.

Energizing

Switch on the auxiliary power supply.

Check that Sepam performs the following initialization sequence, which lasts approximately 6 seconds:

- green ON and red indicators on
- red indicator off
- pick-up of "watchdog" contact.

The first screen displayed is the phase current measurement screen.

Implementation of the SFT2841 software for PC

1. Start up the PC.
2. Connect the PC RS 232 serial port to the communication port on the front panel of Sepam using the CCA783 cord.
3. Start up the SFT2841 software, by clicking on the related icon.
4. Choose to connect to the Sepam to be checked.

Identification of Sepam

1. Note the Sepam serial number given on the label stuck to the right side plate of the base unit.
2. Note the references defining the type of application indicated on the adhesive label on the Sepam cartridge.
3. Note the Sepam type and software version using the SFT2841 software, "Sepam Diagnosis" screen.
4. Enter them in the test sheet.

Determination of parameter and protection settings

All of the Sepam parameter and protection settings are determined ahead of time by the design department in charge of the application, and should be approved by the customer.

It is presumed that the study has been carried out with all the attention necessary, or even consolidated by a network coordination study.

All of the Sepam parameter and protection settings should be available at the time of commissioning:

- in paper file format (with the SFT2841 software, the parameter and protection setting file for a Sepam may be printed directly)
- and, when applicable, in the format of a file to be downloaded into Sepam using the SFT2841 software.

Checking of parameters and protection settings

Check to be made when the Sepam parameter and protection settings have not been entered or downloaded during commissioning testing, to confirm the conformity of the parameter and protection settings entered with the values determined during the study.

The aim of this check is not to confirm the relevance of the parameter and protection settings.

1. Go through all the parameter and protection setting screens in the SFT2841 software, in the order proposed in guided mode
2. For each screen, compare the values entered in the Sepam with the values recorded in the parameter and protection setting file
3. Correct any parameter and protection settings that have not been entered correctly, proceeding as indicated in the SFT2841 section of the Use chapter of this manual.

Conclusion

Once the checking has been done and proven to be conclusive, as of that phase, the parameter and protection settings should not be changed any further and are considered to be final.

In order to be conclusive, the tests which follow must be performed with these parameter and protection settings; no temporary modification of any of the values entered, with the aim of facilitating a test, is permissible.

Checking of phase current and voltage input connections With 3-phase generator

Procedure

1. Connect the 3-phase voltage and current generator to the corresponding test terminal boxes, using the plugs provided, according to the appropriate diagram in terms of the number of VTs connected to Sepam.

Block diagram with 3 VTs connected to Sepam

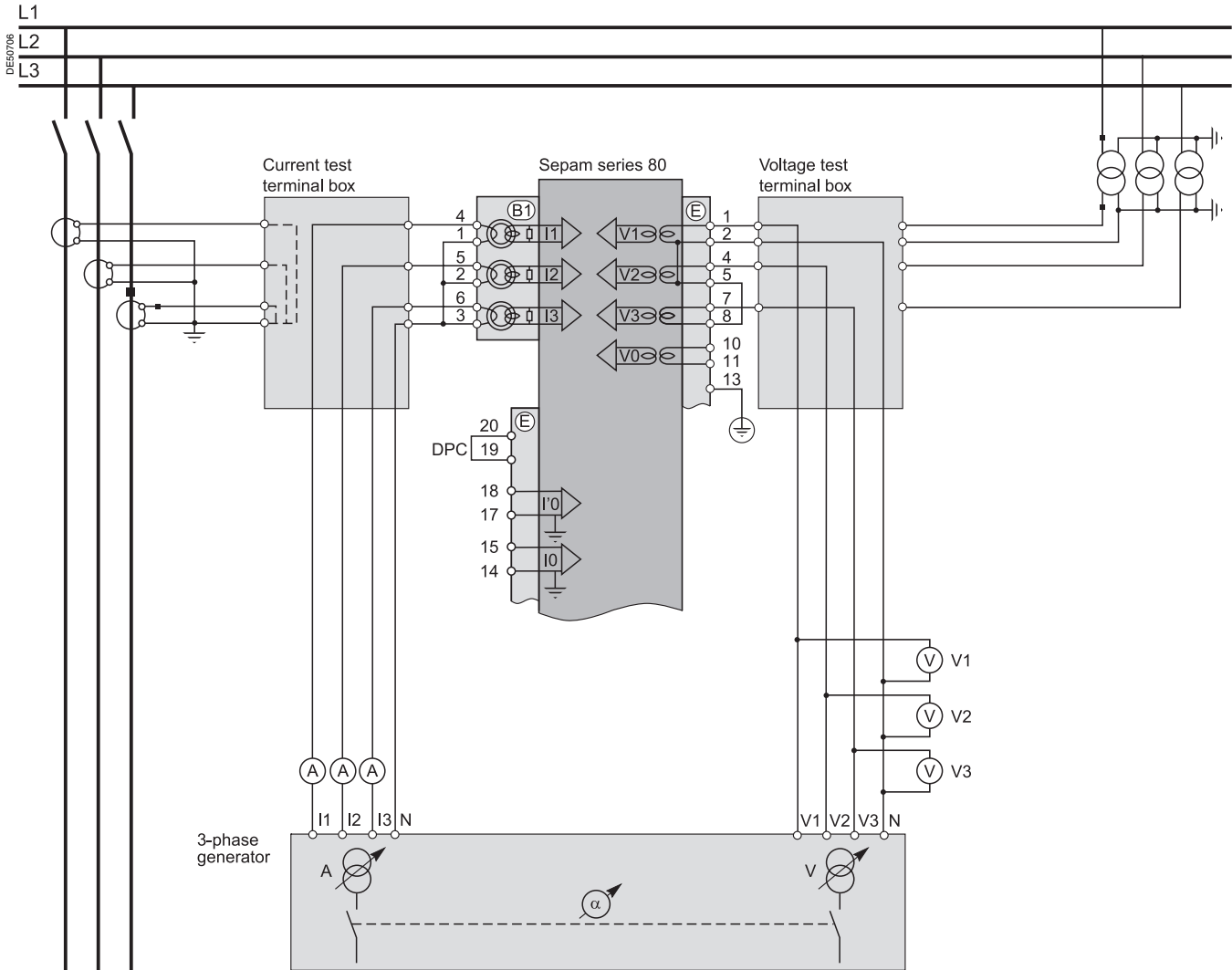

3

Checking of phase current and voltage input connections

With single-phase generator and voltages delivered by 3 VTs

Procedure

1. Connect the single-phase voltage and current generator to the corresponding test terminal boxes, using the plugs provided, according to the block diagram below.

Block diagram

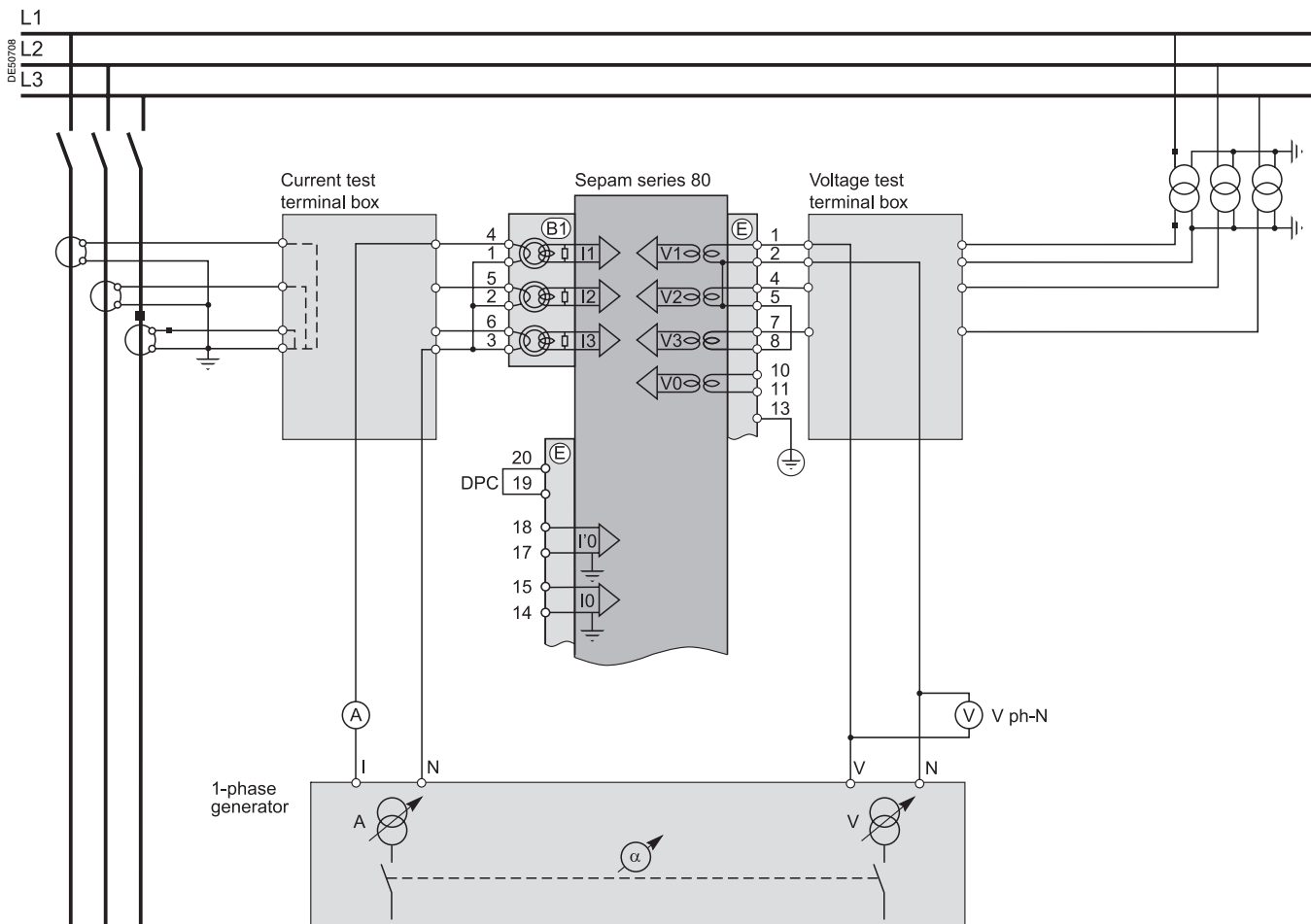

2. Turn the generator on.
3. Apply the generator V-N voltage set to the rated secondary phase-to-neutral voltage of the VTs (i.e. $V_{ns} = U_{ns}/\sqrt{3}$) between Sepam's phase 1 voltage input terminals (via the test box).
4. Inject the generator I current, set to the rated secondary current of the CTs (i.e. 1 A or 5 A) and in phase with the V-N voltage applied (i.e. generator phase displacement $\alpha(V-N, I) = 0^\circ$) to Sepam's phase 1 current input (via the text box).
5. Use the SFT2841 software to check the following:
 - the value indicated for I1 phase current is approximately equal to the rated primary current of the CT
 - the value indicated for V1 phase-to-neutral voltage is approximately equal to the rated primary phase-to-neutral voltage of the VT ($V_{np} = U_{np}/\sqrt{3}$)
 - the value indicated for the phase displacement $\varphi_1(V1, I1)$ between the I1 current and V1 voltage is approximately equal to 0°
6. proceed in the same way by circular permutation with the phase 2 and 3 voltages and currents, to check the I2, V2, $\varphi_2(V2, I2)$ and I3, V3, $\varphi_3(V3, I3)$ values
7. Turn the generator off.

Checking of phase current and voltage input connections

With single-phase generator and voltages delivered by 2 VTs

Description

Check to be carried out when the voltages are supplied by a 2 VT assembly, with the VT primary circuits connected between phases of the distributed voltage, which means that the residual voltage is obtained outside Sepam (by 3 VTs connected via their secondary circuits in an open delta arrangement) or, when applicable, is not used for the protection function.

Procedure

1. Connect the single-phase voltage and current generator to the corresponding test terminal boxes, using the plugs provided, according to the block diagram below.

Block diagram

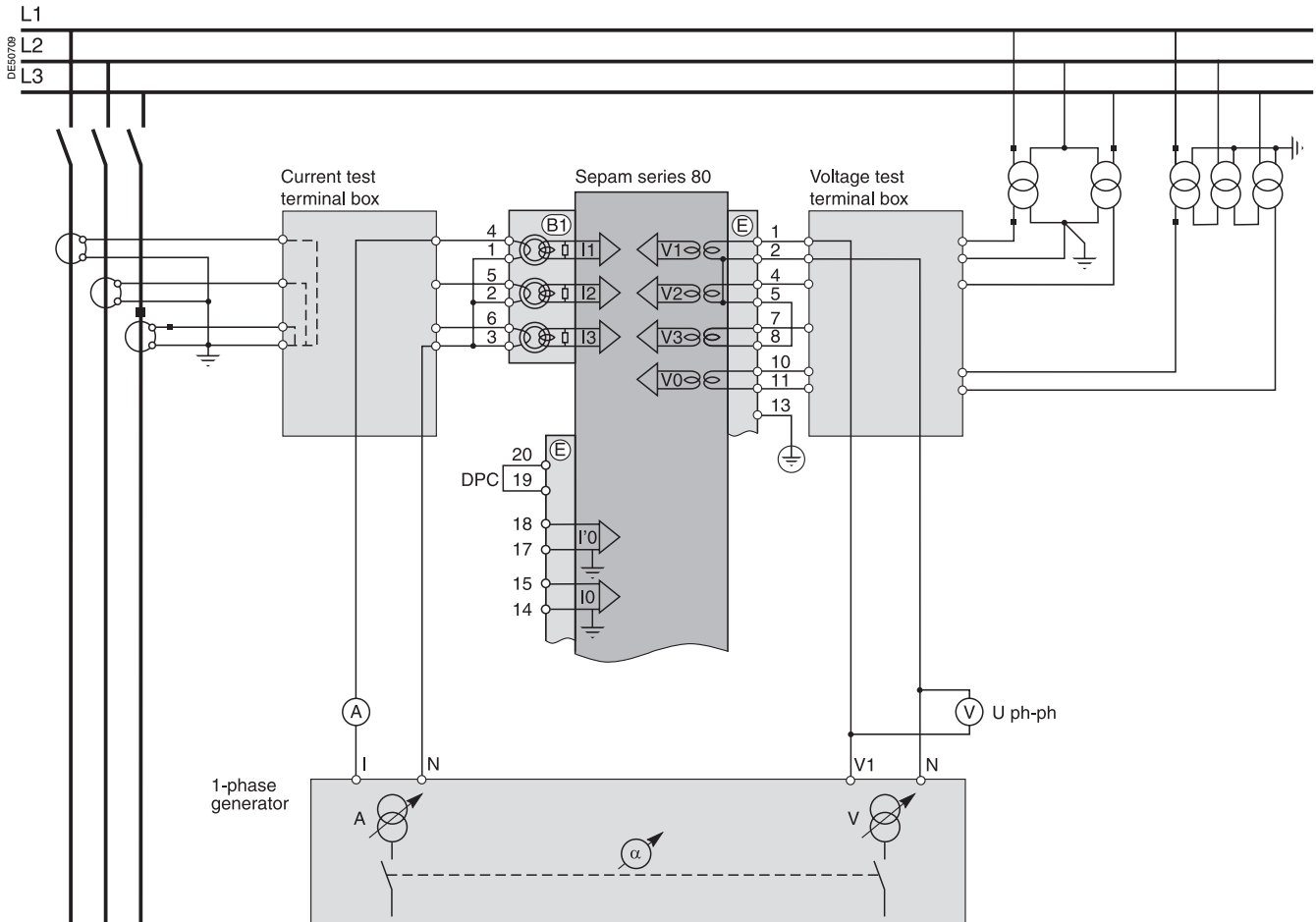

2. Turn the generator on.
3. Apply (via the test box) the voltage delivered at the V-N terminals of the generator, set to $\sqrt{3}/2$ times the rated secondary phase-to-phase voltage of the VTs (i.e. $\sqrt{3} U_{ns}/2$) between terminals 1-2 of Sepam's voltage inputs.
4. Inject the generator I current, set to the rated secondary current of the CTs (i.e. 1 A or 5 A) and in phase with the V-N voltage applied (i.e. generator phase displacement $\alpha(V-N, I) = 0^\circ$) to Sepam's phase 1 current input (via the test box).
5. Use the SFT2841 software to check the following:
 - the value indicated for I1 phase current is approximately equal to the rated primary current of the CT (I_{np}).
 - the value indicated for V1 phase-to-neutral voltage is approximately equal to the rated primary phase-to-neutral voltage of the VT ($V_{np} = U_{np}/\sqrt{3}$)
 - the value indicated for the phase displacement $\varphi_1(V1, I1)$ between the I1 current and V1 voltage is approximately equal to 0°

6. Proceed in the same way to check the I2, V2, $\varphi_2(V2, I2)$ values:
 - apply the generator V-N voltage set to $\sqrt{3} U_{ns}/2$ in parallel between terminals 1-2 and 4-2 of Sepam's voltage inputs (via the test box).
 - inject an I current set to 1 A or 5 A and in phase opposition with the V-N voltage (i.e. $\alpha(V-N, I) = 180^\circ$) to Sepam's phase 2 current input (via the test box)
 - obtain $I2 \cong I_{np}$, $V2 \cong V_{np} = U_{np}/\sqrt{3}$ and $\varphi_2 \cong 0^\circ$. In the absence of residual voltage, $V3 = 0$, $U_{32} = \sqrt{3} U_{np}/2$
7. check the I3, V3, $\varphi_3(V3, I3)$ values as well:
 - apply the generator V-N voltage set to $\sqrt{3} U_{ns}/2$ between terminals 4-2 of Sepam's voltage inputs (via the test box)
 - inject a current equal to 1 A or 5 A and in phase with the V-N voltage (i.e. $\alpha(V-N, I) = 0^\circ$) to Sepam's phase 3 current input (via the test box)
 - obtain $I3 \cong I_{np}$, $V3 \cong V_{np} = U_{np}/\sqrt{3}$ and $\varphi_3 \cong 0^\circ$. In the absence of residual voltage, $V3 = 0$, $U_{32} = \sqrt{3} U_{np}/2$
8. Turn the generator off.

Checking of phase current input connections

For differential applications

Description

Check to be carried out for differential applications (machine, transformer or transformer-machine unit). This test is carried out along with checking of the phase current and phase voltage input wiring. The purpose is to check the wiring of the second Sepam current input.

Procedure

1. Connect the generator current terminals to the corresponding current test terminal boxes using the plugs provided, according to the block diagram below.

Block diagram

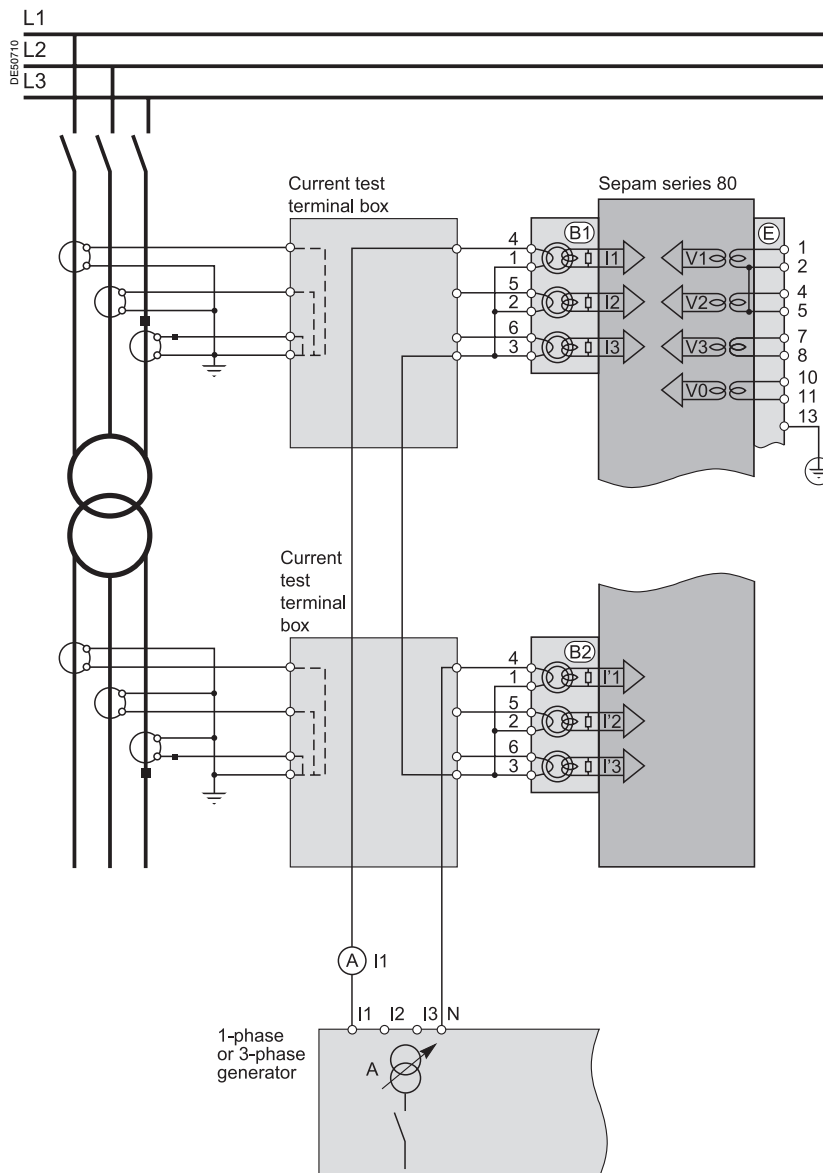

3



Should the secondary circuits of the CTs connected to each of the Sepam current inputs not have the same ratings (1 and 5 A or 5 and 1 A), set the injection to the lowest secondary rating. The value indicated for the phase currents (I1, I2, I3) or (I'1, I'2, I'3), as the case may be, is then equal to the CT rated primary current divided by 5 (In/5).

2. Turn the generator on.
3. Inject, in series, into the phase 1 current input terminals of each Sepam connector (B1, B2) connected in opposition (via the test boxes, according to the diagram above), current I from the generator, set to match the CT rated secondary current (1 A or 5 A).
4. Use the SFT2841 software to check the following:
 - the value indicated for phase current I1 is approximately equal to the rated primary current of the CT (In) wired to the Sepam (B1) connector
 - the value indicated for phase current I'1 is approximately equal to the rated primary current of the CT (I'n) wired to the Sepam (B2) connector
 - the value indicated for the phase displacement $\theta(I, I')$ between currents I1 and I'1 is equal to 0°
5. Check the I2 and I'2, I3 and I'3 and $\theta(I, I')$ values as well the values between I2-I'2 and I3-I'3 after transferring the injection plugs to the phase 2 current and then phase 3 current input terminals of each of the Sepam connectors.
6. Turn the generator off.

Checking of phase current input connections LPCT type current sensors

Phase current measurement by LPCT sensors

- The 3 LPCT current sensors are connected via an RJ45 plug to the CCA671 connector which is to be mounted on the rear panel of Sepam, identified as (B1) and/or (B2).
- The connection of only one or two LPCT sensors is not allowed and causes Sepam to go into the fail-safe position.
- The rated primary current I_n measured by the LPCT sensors is to be entered as a Sepam general setting and configured by microswitches on the CCA671 connector.

Restrictions on the use of LPCT type current sensors

- LPCT type current sensors may not be used for the following measurements:
- phase current measurements for Sepam T87, M88 and G88 units with ANSI 87T transformer differential protection ((B1) and (B2) connectors)
 - phase current measurement for Sepam B83 ((B1) connector)
 - unbalance current measurement for Sepam C86 ((B2) connector).

Procedure

The tests to be carried out to check phase current input connections are the same whether the phase currents are measured by CTs or LPCT sensors. Only the Sepam current input connection procedure and current injection values change.

To test current inputs connected to LPCT sensors with a standard injection box, the ACE917 injection adapter is required.

The ACE917 adapter is inserted between:

- the standard injection box
- the LPCT test plug:
 - integrated in the Sepam CCA671 connector
 - or transferred by means of the CCA613 accessory.

The ACE917 injection adapter should be set according to the currents selected on the CCA671 connector: the ACE917 setting should be equal to the number of the microswitch that is set to 1 on the CCA671.

The injection value depends on the rated primary current selected on the CCA671 connector and entered in the Sepam general settings, i.e.:

- 1 A for the following values (in Amps): 25, 50, 100, 133, 200, 320, 400, 630
- 5 A for the following values (in Amps): 125, 250, 500, 666, 1000, 1600, 2000, 3150.

Block diagram (without CCA613 accessory)

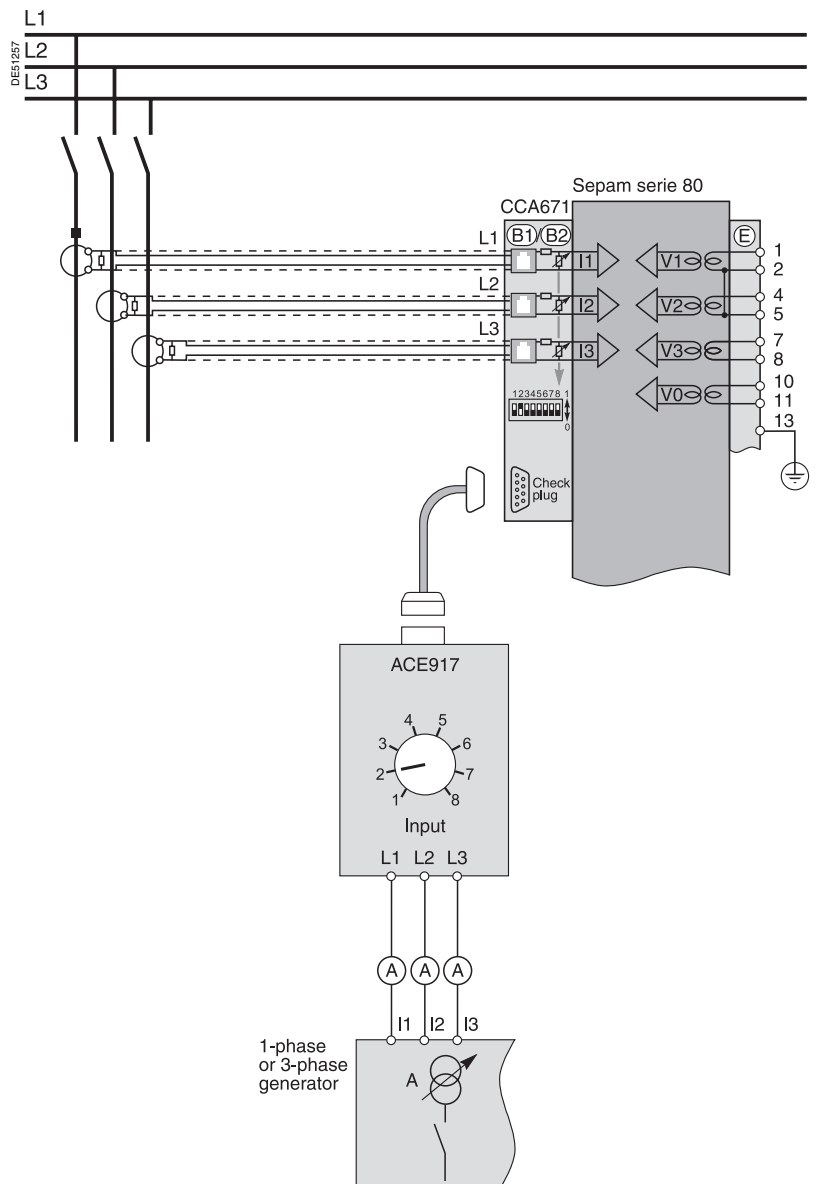

Checking of residual current and residual voltage input connections

Description

Check to be carried out when the residual voltage is delivered by 3 VTs on the secondary circuits connected in an open delta arrangement and when the residual current is obtained by a specific sensor such as:

- CSH120 or CSH200 core balance CT
- CSH30 interposing ring CT (whether it is installed on the secondary circuit of a single 1 A or 5 A CT which encompasses the 3 phases, or on the neutral connection of the three 1 A or 5 A phase CTs)
- other core balance CT connected to an ACE990 interface.

Procedure

1. Connect according to the diagram below:
 - the generator voltage terminals to the voltage test terminal box using the plug provided,
 - a wire between the generator current terminals to inject current into the primary circuit of the core balance CT or CT, with the wire passing through the core balance CT or CT in the P1-P2 direction, with P1 the busbar end and P2 the cable end.

Block diagram

Note: the number of CTs/VTs connected to the Sepam current/voltage connector phase inputs is given as an example and is not used for the test.

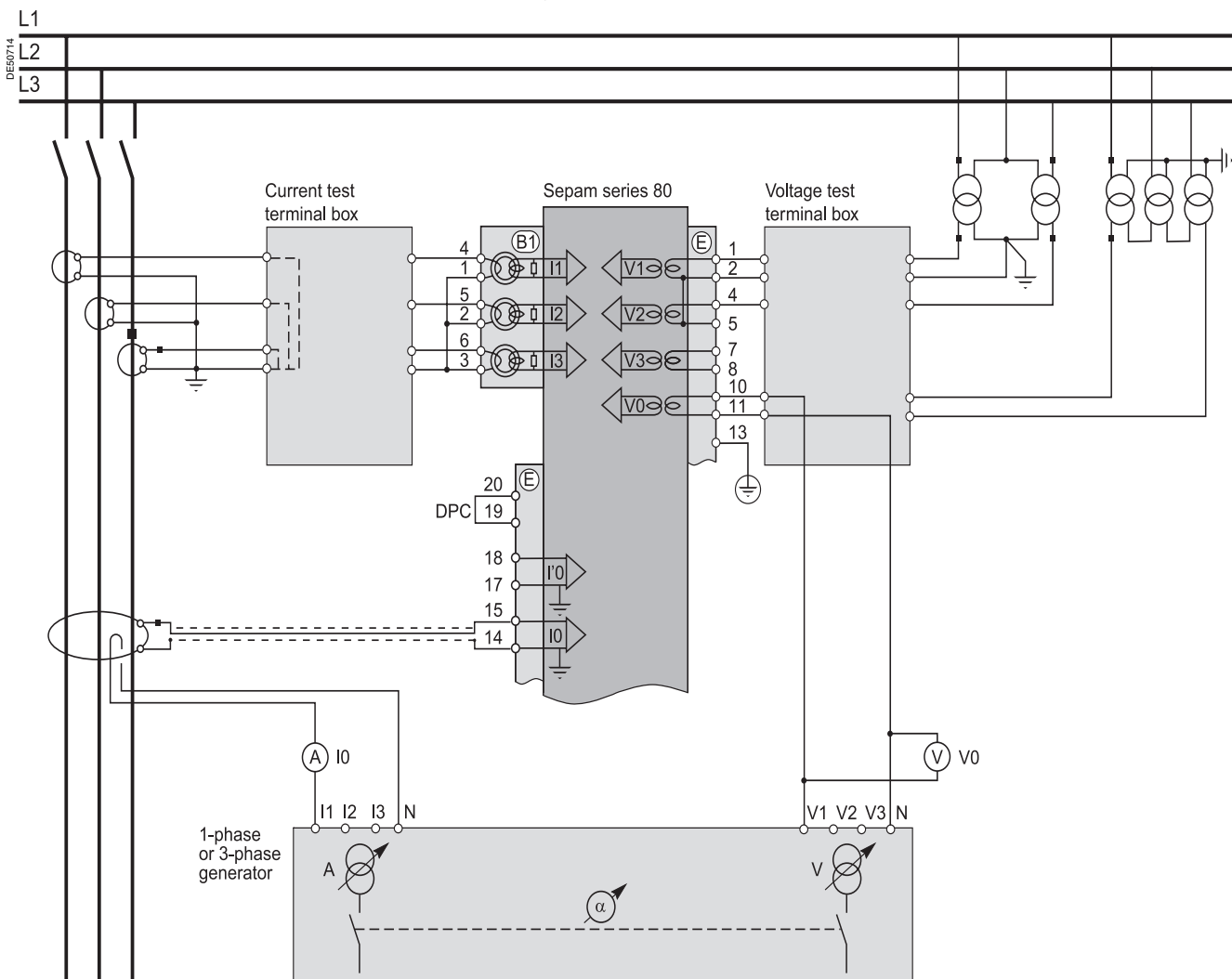

Sepam series 80 is equipped with 2 independent residual current inputs which may be connected to a core balance CT installed on the cables, tank earthing cable or neutral point of a transformer, or on the earthing cable of a motor or generator. In some cases, reading of the $\varphi 0$ or $\varphi'0$ angle is impossible due to the position of the core balance CT (e.g.: transformer tank earthing cable or neutral point) or because only one of the two $I0$ or $V0$ measurements is necessary or possible. When this is the case, simply check the measured residual current value $I0$ or $I'0$.

2. Turn the generator on.
3. Apply a V-N voltage set to the rated secondary voltage of the VTs connected in an open delta arrangement (i.e. $U_{ns}/\sqrt{3}$ or $U_{ns}/3$)
4. inject an I current set to 5 A, and in phase with the voltage applied (i.e. generator phase displacement $\alpha(V-N, I) = 0^\circ$).
5. Use the SFT2841 software to check the following:
 - the value indicated for the measured $I0$ residual current is approximately equal to 5 A
 - the value indicated for the measured $V0$ residual voltage is approximately equal to the rated primary phase-to-neutral voltage of the VTs (i.e. $V_{np} = U_{np}/\sqrt{3}$)
 - the value indicated for the phase displacement $\varphi 0(V0, I0)$ between the $I0$ current and $V0$ voltage is approximately equal to 0°
6. Use the same procedure if the $I'0$ input is connected. When this is the case, the phase displacement angle to be checked is $\varphi'0(V0, I'0)$, between the $I'0$ current and $V0$ voltage.
7. Turn the generator off.

Description

Check to be carried out when the residual current is measured by a specific sensor such as:

- CSH120 or CSH200 core balance CT
- CSH30 interposing ring CT (whether it is installed on the secondary circuit of a single 1 A or 5 A CT which encompasses the 3 phases, or on the neutral connection of the three 1 A or 5 A phase CTs)
- other core balance CT connected to an ACE990 interface,
- and when the residual voltage is calculated in Sepam or cannot be calculated (e.g.: assembly with 2 VTs connected via their primary circuits) and is therefore not available for the protection function.

Procedure

1. Connect according to the diagram below:
 - a wire between the generator current terminals to inject current into the primary circuit of the core balance CT or CT, with the wire passing through the core balance CT or CT in the P1-P2 direction, with P1 the busbar end and P2 the cable end
 - when applicable, the generator voltage terminals to the voltage test terminal box, so as to only supply Sepam's phase 1 voltage input and therefore obtain a residual voltage $V_0 = V_1$.

Block diagram

Note: the number of CTs connected to the Sepam current connector phase inputs is given as an example and is not used for the test.

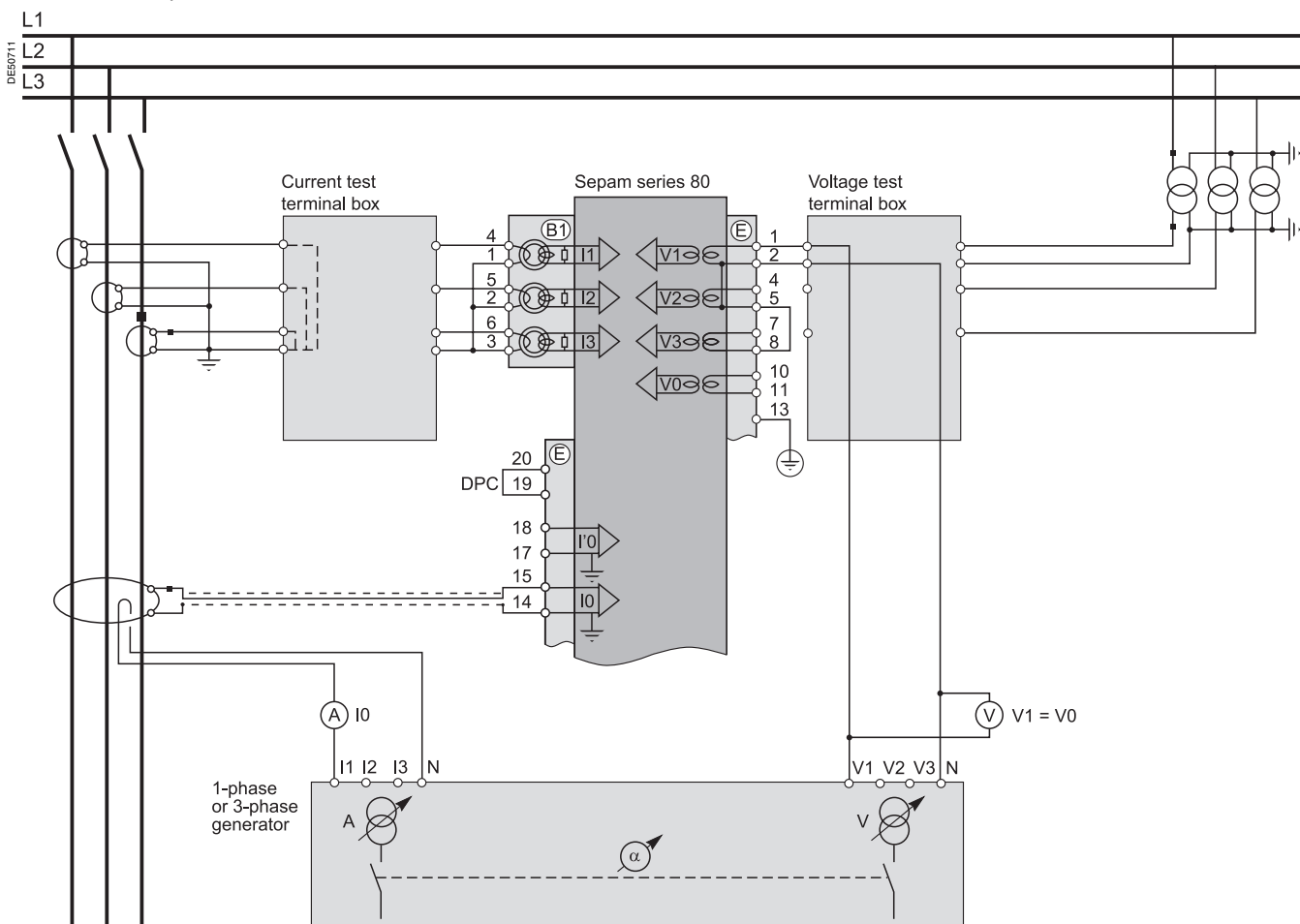

Sepam series 80 is equipped with 2 independent residual current inputs which may be connected to a core balance CT installed on the cables, tank earthing cable or neutral point of a transformer, or on the earthing cable of a motor or generator. In some cases, reading of the φ_0 or φ'_0 angle is impossible due to the position of the core balance CT (e.g. transformer neutral point or tank earthing cable) or because only one of the two I_0 or V_0 measurements is necessary or possible. When this is the case, simply check the measured residual current value I_0 or I'_0 .

2. Turn the generator on.
3. When applicable, apply a V-N voltage set to the rated secondary phase-to-neutral voltage of the VT (i.e. $V_{ns} = U_{ns}/\sqrt{3}$).
4. Inject an I current set to 5 A, and when applicable in phase with the V-N voltage applied (i.e. generator phase displacement $\alpha(V-N, I) = 0^\circ$).
5. Use the SFT2841 software to check the following:
 - the value indicated for the measured I_0 residual current is approximately equal to 5 A
 - when applicable, the value indicated for calculated V_0 residual voltage is approximately equal to the rated primary phase-to-neutral voltage of the VTs (i.e. $V_{np} = U_{np}/\sqrt{3}$)
 - when applicable, the value indicated for the phase displacement φ_0 (V_0, I_0) between the I_0 current and V_0 voltage is approximately equal to 0°
6. Use the same procedure if the I'_0 input is connected. When this is the case, the phase displacement angle to be checked is $\varphi'_0(V_0, I'_0)$, between the I'_0 current and V_0 voltage.
7. Turn the generator off.

Checking of residual voltage input connection

With voltage delivered by 3 VTs in open delta arrangement

Description

Check to be carried out when the residual voltage is delivered by 3 VTs on the secondary circuits connected in an open delta arrangement, and when the residual current is calculated in Sepam or cannot be calculated (e.g.: assembly with 2 CTs) and is therefore not available for the protection function.

Procedure

1. Connect according to the diagram below:

- the generator voltage terminals to the voltage test terminal box, so as to only supply Sepam's residual voltage input
- when applicable, the generator current terminals to the current test terminal box, so as to only supply Sepam's phase 1 current input, and therefore obtain a residual current $I0\Sigma = I1$.

Block diagram

Note: the number of VTs connected to the Sepam voltage connector phase inputs is given as an example and is not used for the test.

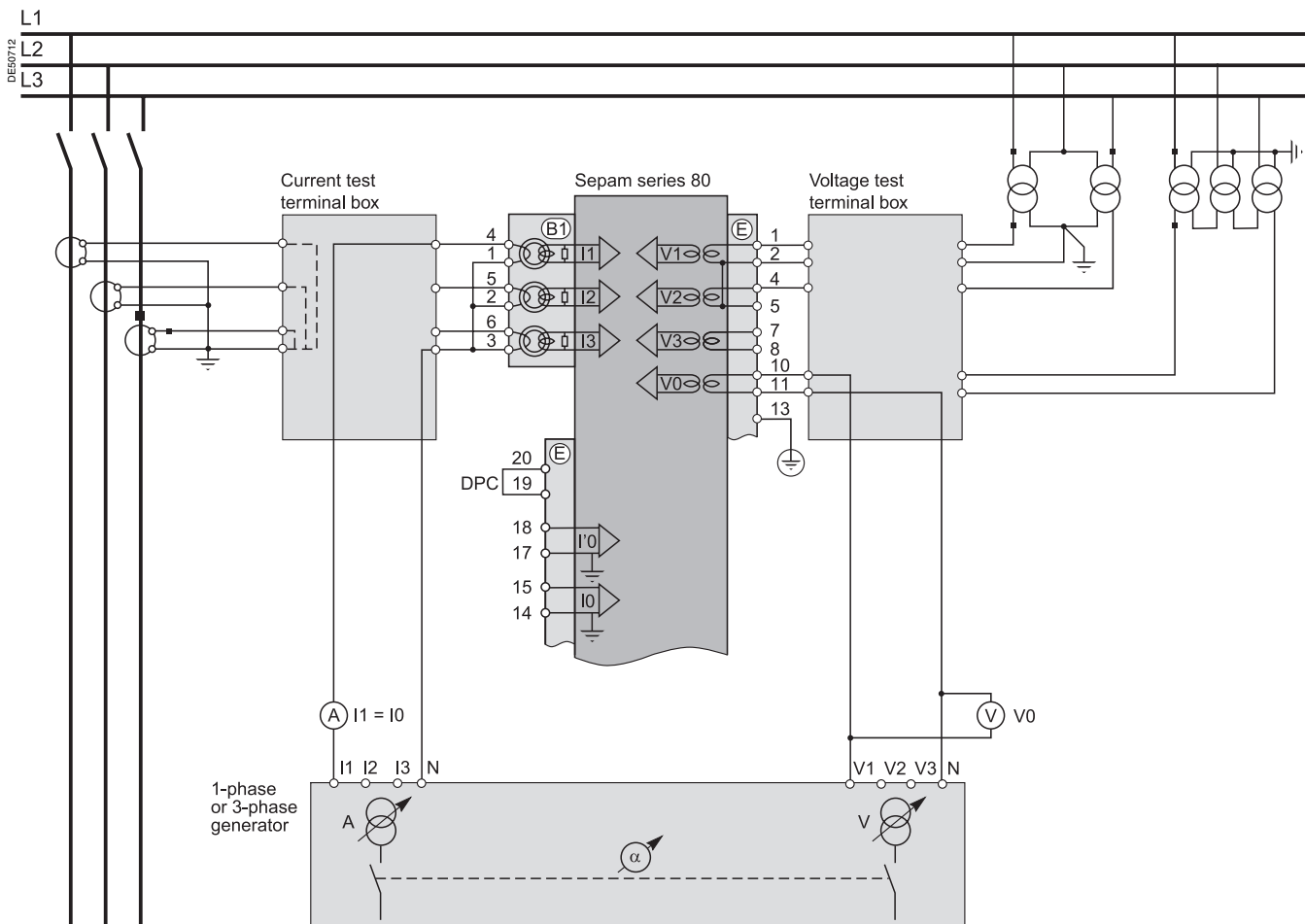

2. Turn the generator on.

3. Apply a V-N voltage set to the rated secondary voltage of the VTs installed in an open delta arrangement (i.e., depending on the case, $Unp/\sqrt{3}$ or $Unp/3$).

4. When applicable, inject an I current set to the rated secondary current of the CTs (i.e. 1 A or 5 A) and in phase with the voltage applied (i.e. generator phase displacement $\alpha(V-N, I) = 0^\circ$).

5. Use the SFT2841 software to check the following:

- the value indicated for the measured $V0$ residual voltage is approximately equal to the rated primary phase-to-neutral voltage of the VTs (i.e. $Vnp = Unp/\sqrt{3}$)

- when applicable, the value indicated for the calculated $I0\Sigma$ residual current is approximately equal to the rated primary current of the CTs

- when applicable, the value indicated for the phase displacement $\varphi0\Sigma (V0, I0\Sigma)$ between the $I0\Sigma$ current and $V0$ voltage is approximately equal to 0°

6. Turn the generator off.

Checking of residual voltage input connection

With voltage delivered by 1 neutral point VT

Description

Check to be carried out when the Sepam residual voltage input is connected to 1 VT installed on the neutral point of a motor or generator (in which case the VT is a power transformer).

Procedure

1. Connect the generator voltage terminals to the voltage test terminal box, so as to only supply Sepam's residual voltage input.

Block diagram

Note: the number of CTs/VTs connected to the Sepam current/voltage connector phase inputs is given as an example and is not used for the test.

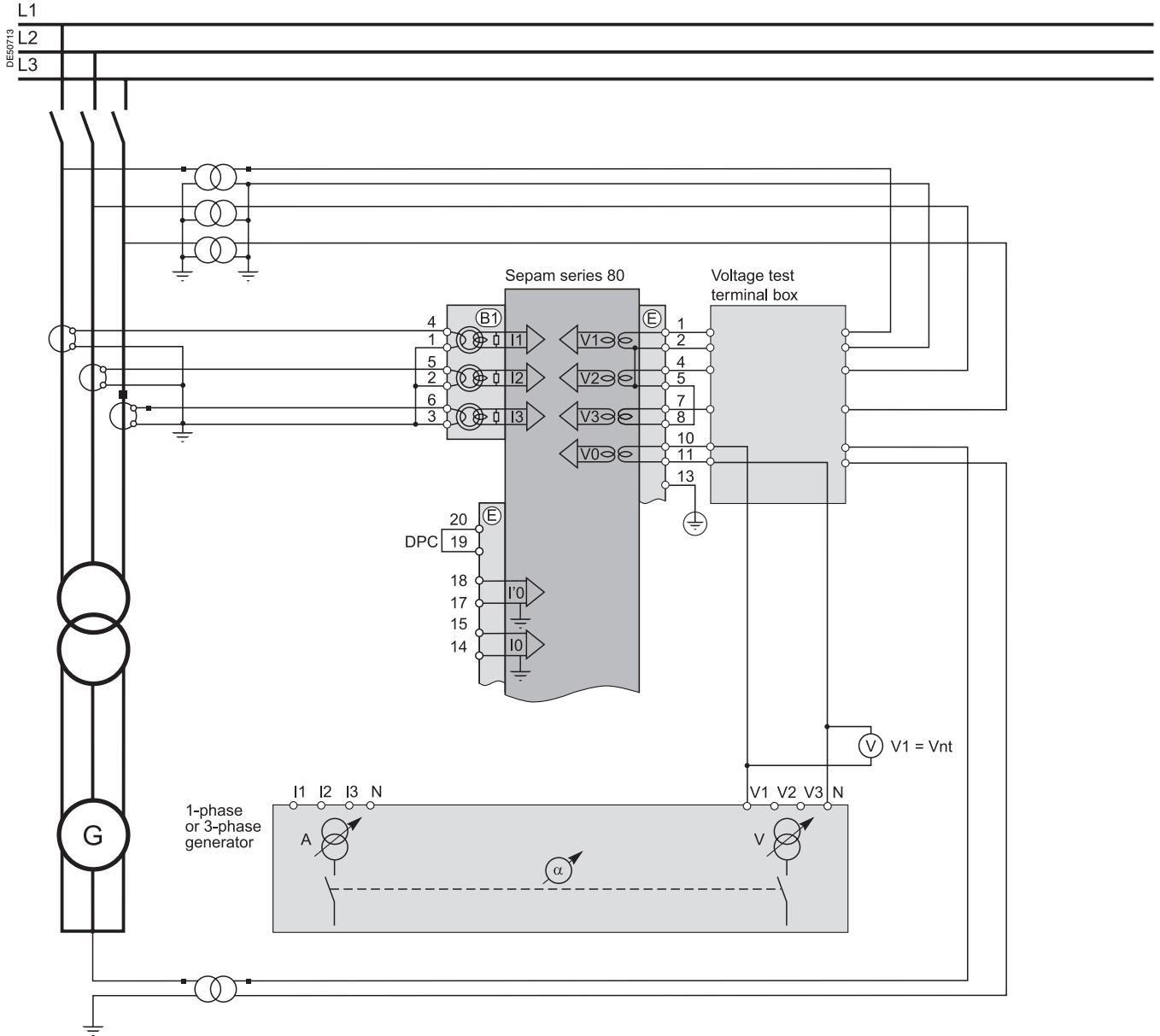

2. Turn the generator on.
3. Apply a V-N voltage set to the rated secondary voltage of the neutral point VT (i.e. V_{nt}).
4. Use the SFT2841 software to check that the measured neutral point voltage V_{nt} is approximately equal to the rated primary phase-to-neutral voltage of the VTs (i.e. V_{nts}).
5. Turn the generator off.

Description

Check to be carried out on Sepam B80 units with additional phase voltage measurement, apart from checking of the main voltage input connections.

The additional phase voltage measured by Sepam B80 is either phase-to-neutral voltage $V'1$ or phase-to-phase voltage $U'21$, according to the VT connected and the Sepam parameter setting mode.

Since the additional voltage measured is not related to the currents measured by Sepam B80, it is not necessary to inject current to check the Sepam B80 additional voltage input connection.

Procedure

Connect the single-phase voltage generator to the corresponding test terminal box, using the plugs provided, according to the diagram for the voltages measured:

■ block diagram 1: Sepam B80 measures the 3 main phase voltages and an additional phase voltage

■ block diagram 2: Sepam B80 measures 2 main phase voltages, the main residual voltage and an additional phase voltage.

Block diagram 1

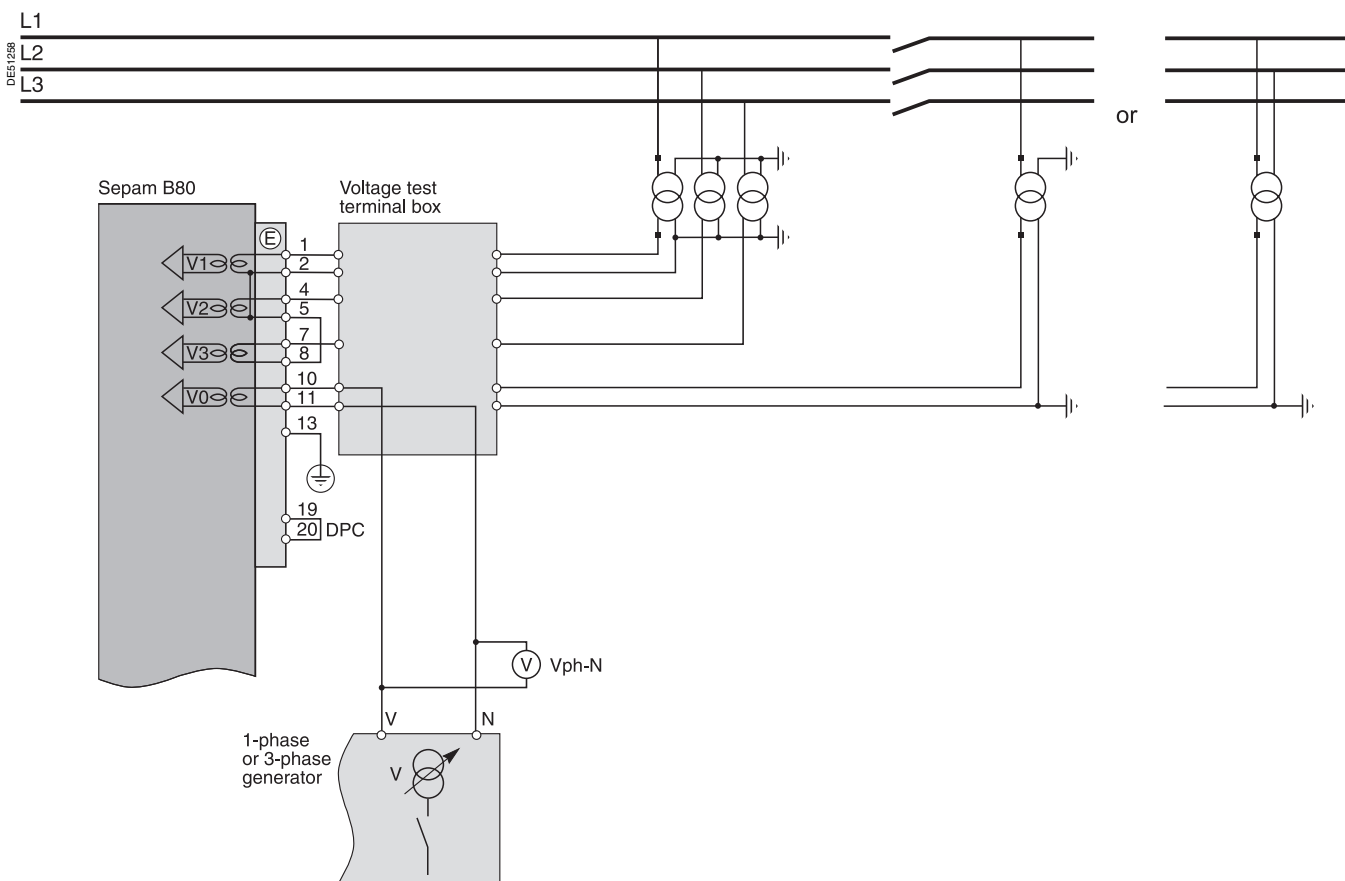

1. Turn the generator on.
2. Apply a voltage V-N set to the rated secondary voltage of the additional VT (i.e. $V'ns = U'ns/3$).
3. Use the SFT2841 software to check that the measured voltage indicated $V'1$ or $U'21$ is approximately equal to the VT's rated primary phase-to-neutral voltage ($V'np = U'np/3$).
4. Turn the generator off.

Block diagram 2

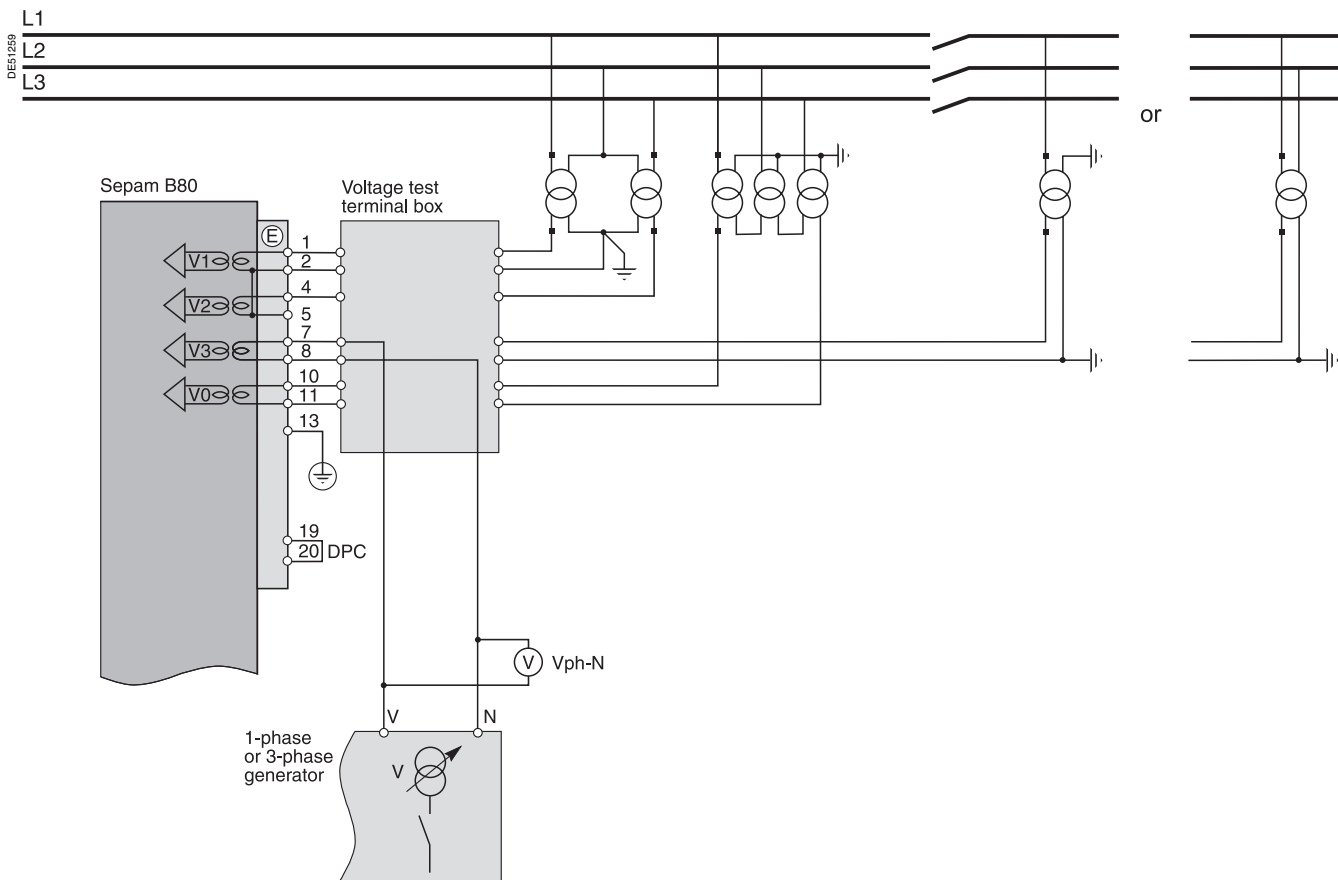

1. Turn the generator on.
2. Apply a voltage V-N set to the rated secondary voltage of the additional VT (i.e. $V'_{ns} = U'_{ns}/\sqrt{3}$).
3. Use the SFT2841 software to check that the measured voltage indicated V'1 or U'21 is approximately equal to the VT's rated primary phase-to-neutral voltage ($V'_{np} = U'_{np}/\sqrt{3}$).
4. Turn the generator off.

Description

Check to be carried out on Sepam B83 units with additional phase voltage measurement, apart from checking of the main voltage input connections.

Since the additional voltages measured are not related to the currents measured by Sepam B83, it is not necessary to inject current to check the Sepam B83 additional phase voltage input connections.

Procedure

Connect the voltage generator to the corresponding test terminal box, using the plugs provided, according to the diagram for the number of VTs connected to Sepam.

Block diagram with 3 additional VTs

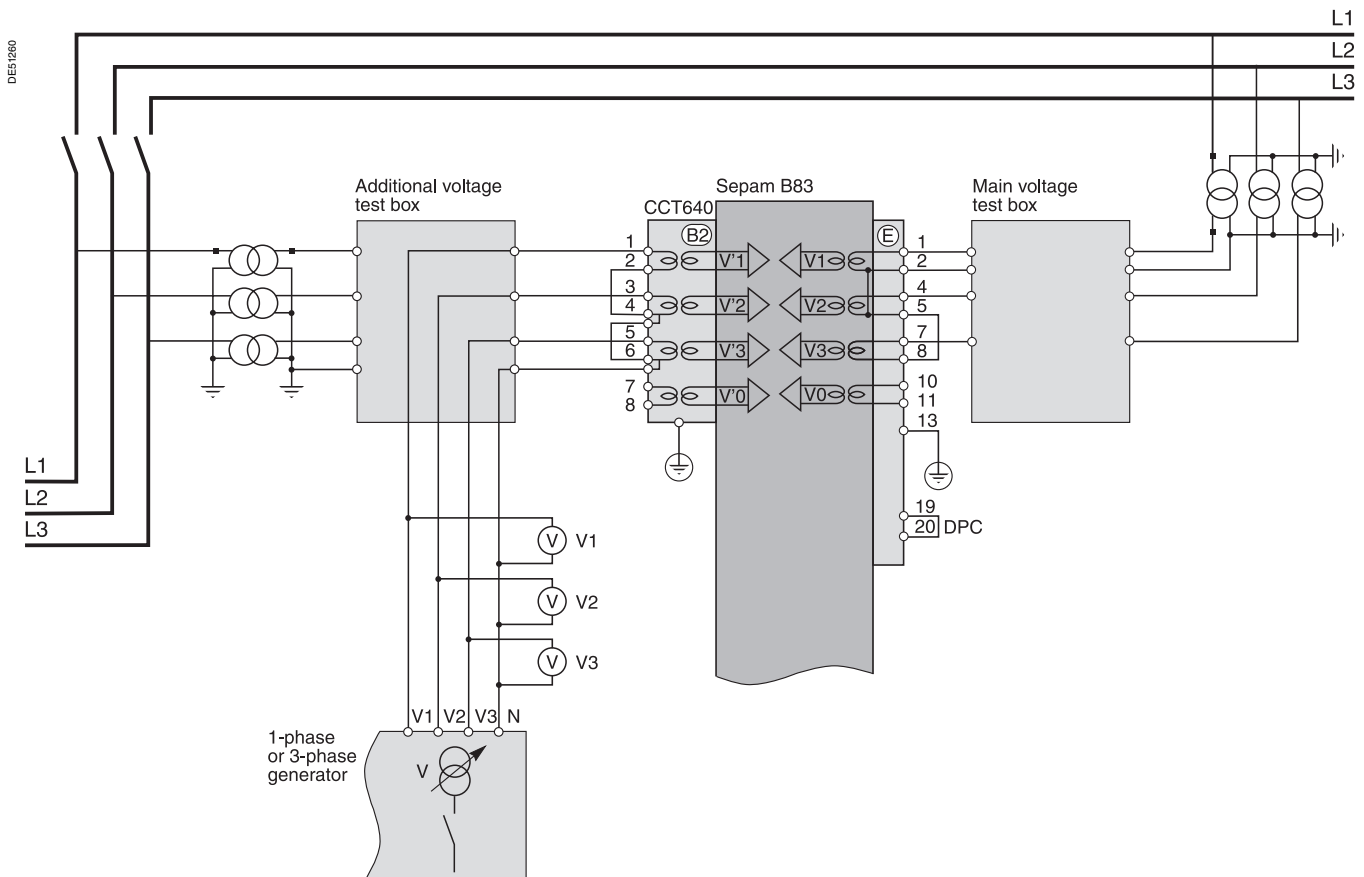

Checking with a three-phase voltage generator

1. Turn the generator on.
2. Apply the 3 generator voltages V1-N, V2-N, V3-N, balanced and set to the rated secondary phase-to-neutral voltage of the additional VTs (i.e. $V'_{ns} = U'_{ns}/\sqrt{3}$).
3. Use the SFT2841 software to check that the values indicated for each of the phase-to-neutral voltages V'1, V'2, V'3 and the positive sequence voltage V'd are approximately equal to the VT's rated primary phase-to-neutral voltage ($V'_{np} = U'_{np}/\sqrt{3}$).
4. Turn the generator off.

Checking with a single-phase voltage generator

1. Turn the generator on.
2. Apply the generator voltage V-N set to the rated secondary phase-to-neutral voltage of the additional VTs (i.e. $V'_{ns} = U'_{ns}/\sqrt{3}$) across the Sepam phase 1 voltage input terminals.
3. Use the SFT2841 software to check that the value indicated for the phase-to-neutral voltage V'1 is approximately equal to the VT's rated primary phase-to-neutral voltage ($V'_{np} = U'_{np}/\sqrt{3}$).
4. Proceed in the same way by circular permutation with the phase 2 and 3 voltages, to check the V'2 and V'3 values.
5. Turn the generator off.

Block diagram with 2 additional VTs

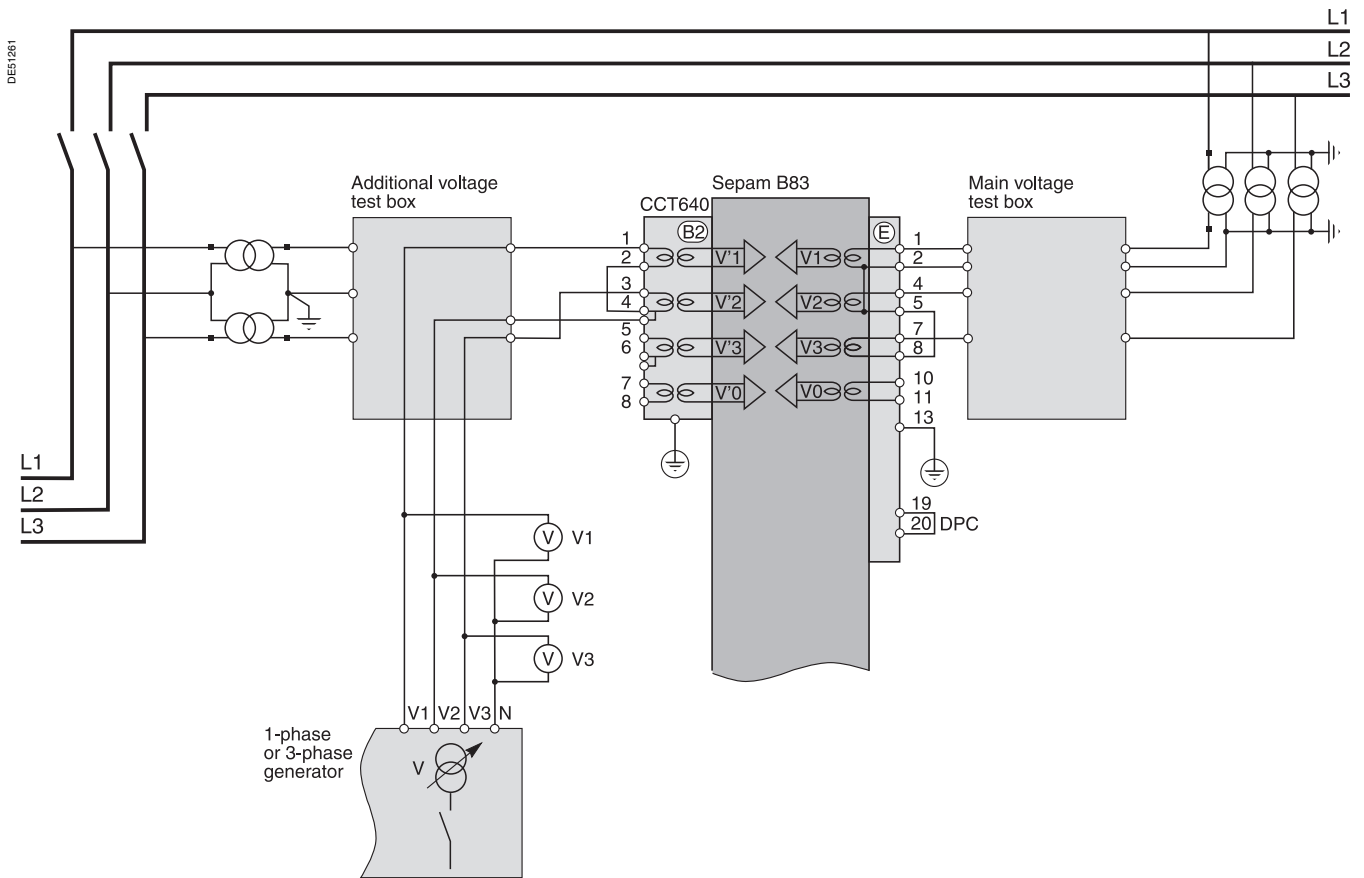
**Checking with a three-phase voltage generator**

1. Turn the generator on.
2. Apply the 3 generator voltages V1-N, V2-N, V3-N, balanced and set to the rated secondary phase-to-neutral voltage of the additional VTs (i.e. $V'_{ns} = U'_{ns}/\sqrt{3}$)
3. Use the SFT2841 software to check that:
 - the values indicated for each of the phase-to-neutral voltages V'1, V'2, V'3 and the positive sequence voltage V'd are approximately equal to the VT's rated primary phase-to-neutral voltage ($V'_{np} = U'_{np}/\sqrt{3}$)
 - the value of each of the phase-to-phase voltages U'21, U'32, U'13 is equal to the VT's rated primary phase-to-phase voltage (U'_{np})
4. Turn the generator off.

Checking with a single-phase voltage generator

1. Turn the generator on.
2. Apply the generator voltage V-N set to the rated secondary phase-to-neutral voltage of the additional VTs (i.e. $V'_{ns} = U'_{ns}/\sqrt{3}$) across Sepam voltage input terminals 1 and 5 (via the text box).
3. Use the SFT2841 software to check that the value indicated for the phase-to-neutral voltage U'21 is approximately equal to the VT's rated primary phase-to-neutral voltage ($V'_{np} = U'_{np}/\sqrt{3}$).
4. Apply the generator voltage V-N set to the rated secondary phase-to-neutral voltage of the additional VTs (i.e. $V'_{ns} = U'_{ns}/\sqrt{3}$) across Sepam voltage input terminals 3 and 5 (via the text box).
5. Use the SFT2841 software to check that the value indicated for the phase-to-neutral voltage U'32 is approximately equal to the VT's rated primary phase-to-neutral voltage ($V'_{np} = U'_{np}/\sqrt{3}$).
6. Turn the generator off.

Description

Check to be carried out on Sepam B83 units with additional voltage measurement, apart from checking of the main voltage input connections. Since the additional residual voltage is not related to the currents measured by Sepam B83, it is not necessary to inject current to check Sepam B83 additional residual voltage input connection.

Procedure

1. Connect the single-phase voltage generator to the corresponding test terminal box, using the plugs provided, according to the block diagram below.

Block diagram

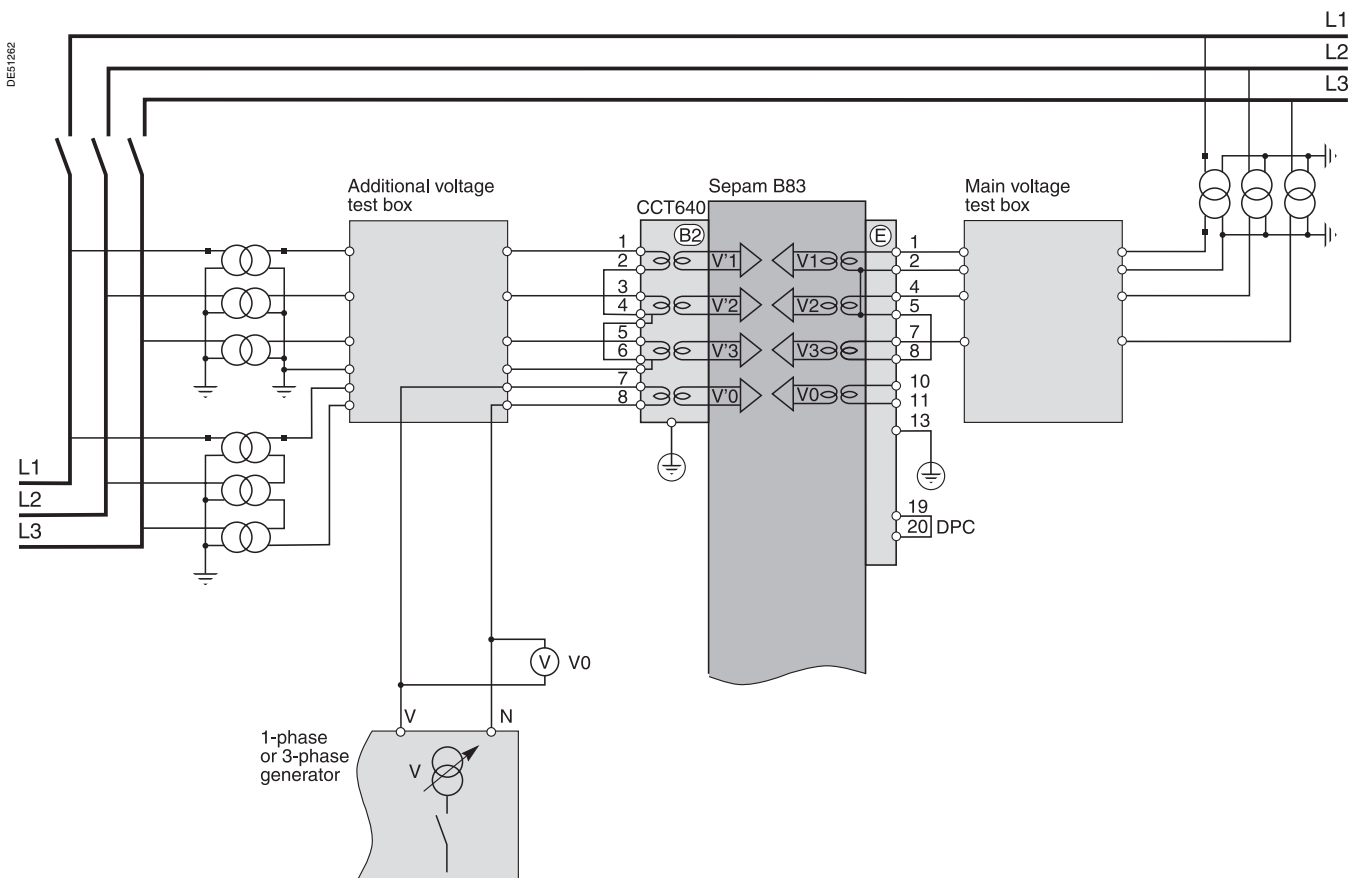

2. Turn the generator on.
3. Apply the generator voltage V-N set to the rated secondary voltage of the additional VTs mounted in an open delta arrangement (i.e., depending on the case, $U'_{ns}/\sqrt{3}$ or $U'_{ns}/3$).
4. Use the SFT2841 software to check that the value indicated for the residual voltage measured V'0 is approximately equal to the VTs' rated primary phase-to-neutral voltage (i.e. $V'_{np} = U'_{np}/\sqrt{3}$).
5. Turn the generator off.

Description

Check to be carried out on Sepam C86 units with measurement of capacitor unbalance currents, apart from checking of the phase current input connections.

Since the capacitor unbalance currents are not related to the voltages measured by Sepam C86, it is not necessary to inject voltage to check the Sepam C86 capacitor unbalance current input connections.

Procedure

1. Connect the single-phase current generator to the corresponding test terminal box, using the plugs provided, according to the block diagram below.

Block diagram

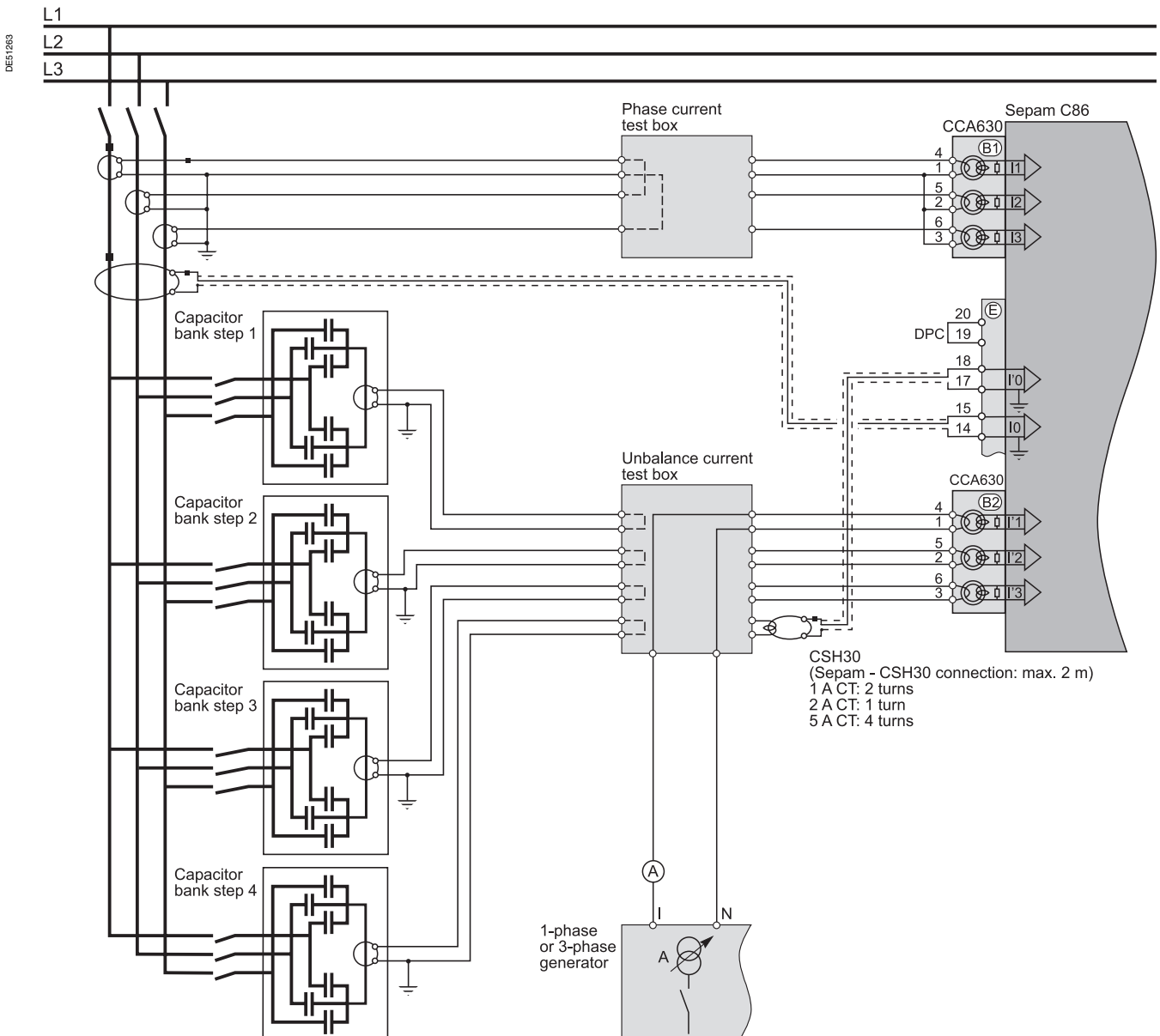

2. Turn the generator on.
3. Inject the generator current I set to the CTs' rated secondary current (i.e. 1 A, 2 A or 5 A) to Sepam's step 1 unbalance input (via the test box).
4. Use the SFT2841 software to check that the unbalance current value indicated $I'1$ is approximately equal to the CTs' rated primary current.
5. Proceed in the same way by circular permutation with the unbalance currents of steps 2, 3 and 4, to check the $I'2$, $I'3$ and $I'0$ values.
6. Turn the generator off.

Checking of logic input connections

Procedure

Proceed as follows for each input:

1. If the input supply voltage is present, use an electric cord to short-circuit the contact that delivers logic data to the input.
2. If the input supply voltage is not present, apply a voltage supplied by the DC voltage generator to the terminal of the contact linked to the chosen input, being sure to comply with the suitable polarity and level.
3. Observe the change of status of the input using the SFT2841 software, in the "Input, output, indicator status" screen
4. At the end of the test, if necessary, press the SFT2841 Reset key to clear all messages and deactivate all outputs.

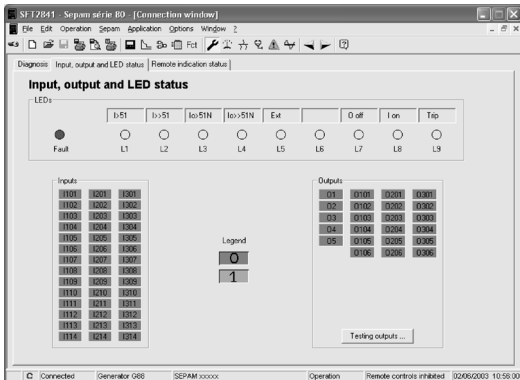

SFT2841: input, output, indicator status.

Checking of logic output connections

Procedure

Check carried out using the "Output relay test" function, activated via the SFT2841 software, in the "Sepam Diagnosis" screen.

Only output O5, when used for the watchdog, can be tested.

1. This function requires prior entry of the "Parameter setting" password.
2. Activate each output relay using the buttons in the SFT2841 software the activated output relay changes status over a period of 5 seconds.
3. Observe the change of status of the output relay through the operation of the related switchgear (if it is ready to operate and is powered), or connect a voltmeter to the terminals of the output contact (the voltage cancels itself out when the contact closes).
4. At the end of the test, press the SFT2841 Reset key to clear all messages and deactivate all outputs.

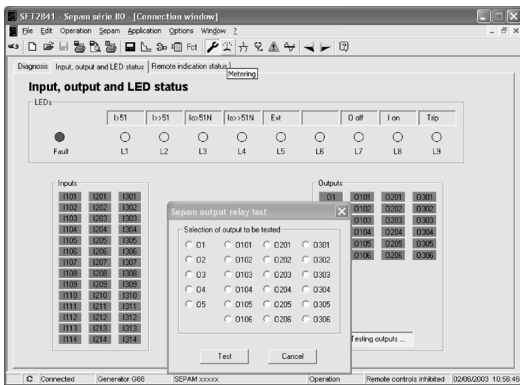

SFT2841: output relay test.

3

MET148-2 module temperature sensor inputs

The temperature monitoring function provided by Sepam T81, T82, T87, M81, M87, M88, G82, G87, G88, C86 units checks the connection of each RTD that is configured.

An "RTD FAULT" alarm is generated whenever one of the RTDs is detected as being short-circuited or disconnected (absent).

To identify the faulty RTD or RTDs:

1. Display the temperature values measured by Sepam using the SFT2841 software.
2. Check the consistency of the temperatures measured:
 - the temperature displayed is "*****" if the RTD is short-circuited ($T < -35\text{ °C}$ or $T < -31\text{ °F}$)
 - the temperature displayed is "-*****" if the RTD is disconnected ($T > 205\text{ °C}$ or $T > 401\text{ °F}$).

MSA141 module analog output

- 1 Identify the measurement associated by parameter setting to the analog output using the SFT2841 software.
- 2 Simulate, if necessary, the measurement linked to the analog output by injection.
- 3 Check the consistency between the value measured by Sepam and the indication given by the device connected to the analog output.

MCS025 module voltage inputs

Procedure

1. Connect the single-phase voltage generator to the corresponding test terminal box, using the plugs provided, according to the block diagram below.

Block diagram

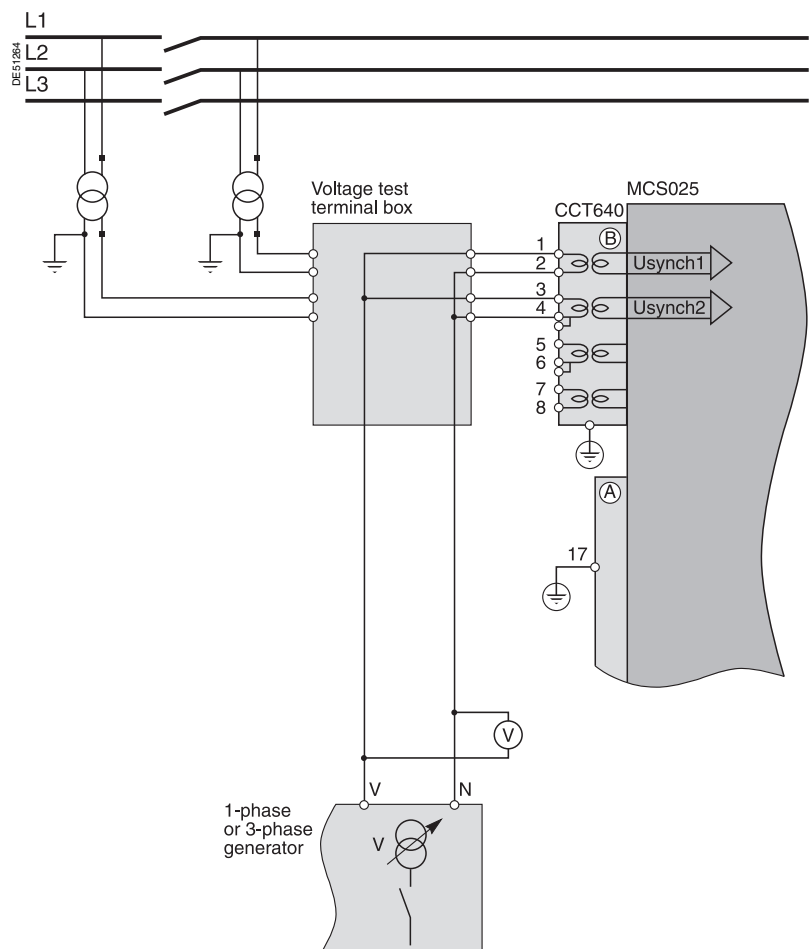

2. Turn the generator on.
3. Apply a voltage V-N set to the rated secondary voltage $V_{ns\ sync1}$ ($V_{ns\ sync1} = U_{ns\ sync1}/3$) in parallel between the input terminals of the 2 voltages to be synchronized.
4. Use the SFT2841 software to check that:
 - the measured voltage difference dU, frequency difference dF and phase difference dPhi values are equal to 0
 - the close enable sent by the MCS025 module is received on the Sepam series 80 logic input assigned to this function (logic input in 1 status in the "Input, output and LED status" screen).
5. Use the SFT2841 software to check that for the other Sepam series 80 units concerned by the "Synchro-check" function the close enable sent by the MCS025 module is received on the logic input assigned to this function (logic input in 1 status in the "Input, output and LED status" screen).
6. Turn the generator off.

Validation of the complete protection chain

Principle

The complete protection chain is validated during the simulation of a fault that causes tripping of the breaking device by Sepam.

Procedure

1. Select one of the protection functions that triggers tripping of the breaking device and separately, according to their incidence in the chain, the function or functions related to the programmed or reprogrammed parts of the program logic.
2. According to the selected function or functions, inject a current and/or apply a voltage that corresponds to a fault.
3. Observe the tripping of the breaking device and the operation of the adapted parts of the program logic.

At the end of all the voltage and current application type checks, put the covers back on the test terminal boxes.

Project:	Type of Sepam	<input type="text"/> <input type="text"/> <input type="text"/>
Switchboard:	Serial number	<input type="text"/> <input type="text"/> <input type="text"/> <input type="text"/> <input type="text"/> <input type="text"/>
Cubicle:	Software version	V <input type="text"/> <input type="text"/> <input type="text"/> <input type="text"/> <input type="text"/>

Overall checks

Check off the box when the check has been made and been conclusive

Type of check	
Preliminary general examination, prior to energizing	<input type="checkbox"/>
Energizing	<input type="checkbox"/>
Parameter and protection settings	<input type="checkbox"/>
Logic input connections	<input type="checkbox"/>
Logic output connections	<input type="checkbox"/>
Validation of the complete protection chain	<input type="checkbox"/>
Validation of the adapted functions (via the logic equation editor or via Logipam)	<input type="checkbox"/>
Analog output connection to the MSA141 module	<input type="checkbox"/>
Temperature sensor input connections to the MET148-2 module	<input type="checkbox"/>
Voltage input connections to the MCS025 module	<input type="checkbox"/>

Checking of phase current and voltage inputs

Check off the box when the check has been made and been conclusive

Type of check	Test performed	Result	Display	
Phase current and phase voltage input connections	Secondary injection of CT rated current into (B1), i.e. 1 A or 5 A	Rated primary current of CTs connected to (B1)	I1 =	<input type="checkbox"/>
			I2 =	<input type="checkbox"/>
			I3 =	<input type="checkbox"/>
	Secondary injection of phase voltage (the value to be injected depends on the test being performed)	VT rated primary phase-to-neutral voltage $Unp/\sqrt{3}$	V1 =	<input type="checkbox"/>
			V2 =	<input type="checkbox"/>
			V3 =	<input type="checkbox"/>
Phase current input connections for differential applications	Secondary injection of CT rated current into (B1)/(B2), i.e. 1 A or 5 A (1 A if secondary ratings are different)	Primary In (or In/5) of CTs connected to (B1) (depending on secondary ratings)	I1 =	<input type="checkbox"/>
			I2 =	<input type="checkbox"/>
			I3 =	<input type="checkbox"/>
		Primary I'n (or I'n/5) of CTs connected to (B2) (depending on secondary ratings)	I'1 =	<input type="checkbox"/>
			I'2 =	<input type="checkbox"/>
			I'3 =	<input type="checkbox"/>
Phase displacement $\varphi(V, I) \cong 0^\circ$		$\varphi1 = \dots\dots\dots$	<input type="checkbox"/>	
		$\varphi2 = \dots\dots\dots$	<input type="checkbox"/>	
		$\varphi3 = \dots\dots\dots$	<input type="checkbox"/>	
Phase displacement $\theta(I, I') \cong 0^\circ$		$\theta(I1, I'1) = \dots\dots\dots$	<input type="checkbox"/>	
		$\theta(I2, I'2) = \dots\dots\dots$	<input type="checkbox"/>	
		$\theta(I3, I'3) = \dots\dots\dots$	<input type="checkbox"/>	

Tests performed on:	Signatures
By:	
Comments:	
.....	
.....	
.....	

Project:	Type of Sepam	<input type="text"/> <input type="text"/> <input type="text"/>
Switchboard:	Serial number	<input type="text"/> <input type="text"/> <input type="text"/> <input type="text"/> <input type="text"/> <input type="text"/>
Cubicle:	Software version	V <input type="text"/> <input type="text"/> <input type="text"/> <input type="text"/>

Residual current and voltage input checks

Check off the box when the check has been made and been conclusive

Type of check	Test performed	Result	Display
Residual current input connection	Injection of 5 A into the core balance CT primary circuit	Injected current value I0 and/or I'0	I0 = <input type="checkbox"/> I'0 = <input type="checkbox"/>
	When applicable, secondary injection of the rated phase-to-neutral voltage of a phase VT $U_{ns}/\sqrt{3}$	VT rated primary phase-to-neutral voltage $U_{np}/\sqrt{3}$	V0 = <input type="checkbox"/>
		Phase displacement $\varphi_0(V_0, I_0)$ and/or $\varphi'_0(V_0, I'_0) \cong 0^\circ$	$\varphi_0 = \dots\dots\dots$ <input type="checkbox"/> $\varphi'_0 = \dots\dots\dots$ <input type="checkbox"/>
Residual voltage input connection To 3 VTs in open delta arrangement	Secondary injection of the rated voltage of the VTs in an open delta arrangement ($U_{np}/\sqrt{3}$ or $U_{np}/3$)	VT rated primary phase-to-neutral voltage $U_{np}/\sqrt{3}$	V0 = <input type="checkbox"/>
	When applicable, secondary injection of CT rated current, i.e. 1 A or 5 A	CT rated primary current	I0Σ = <input type="checkbox"/>
		Phase displacement $\varphi_{0\Sigma}(I_0, I_{0\Sigma})$	$\varphi_{0\Sigma} = \dots\dots\dots$ <input type="checkbox"/>
To 1 neutral point VT	Secondary injection of the rated voltage of the neutral point VT (Vnts)	VT rated primary phase-to-neutral voltage Vntp	Vnt = <input type="checkbox"/>
Residual current and residual voltage input connections	Injection of 5 A into the core balance CT primary circuit	Injected current value I0 and/or I'0	I0 = <input type="checkbox"/> I'0 = <input type="checkbox"/>
	Secondary injection of the rated voltage of the VTs in an open delta arrangement ($U_{np}/\sqrt{3}$ or $U_{np}/3$)	VT rated primary phase-to-neutral voltage $U_{np}/\sqrt{3}$	V0 = <input type="checkbox"/>
		Phase displacement $\varphi_0(V_0, I_0)$ and/or $\varphi'_0(V_0, I'_0) \cong 0^\circ$	$\varphi_0 = \dots\dots\dots$ <input type="checkbox"/> $\varphi'_0 = \dots\dots\dots$ <input type="checkbox"/>

Tests performed on:	Signatures
By:	
Comments:	
.....	
.....	
.....	

3

Project:	Type of Sepam	<input type="text"/> <input type="text"/> <input type="text"/>
Switchboard:	Serial number	<input type="text"/> <input type="text"/> <input type="text"/> <input type="text"/> <input type="text"/> <input type="text"/> <input type="text"/>
Cubicle:	Software version	V <input type="text"/> <input type="text"/> <input type="text"/> <input type="text"/>

Special checks

Check off the box when the check has been made and been conclusive

Type of check	Test performed	Result	Display
Sepam B80: additional phase voltage input connection	Secondary injection of the rated phase-to-neutral voltage of an additional phase VT $U'_{np}/\sqrt{3}$	Rated primary voltage of additional VTs $U'_{np}/\sqrt{3}$	V'1 or U'21 = <input type="checkbox"/>
Sepam B83: additional phase voltage input connections	Secondary injection of the additional rated phase to neutral voltage $U'_{np}/\sqrt{3}$	Rated primary phase-to-neutral voltage of additional VTs $U'_{np}/\sqrt{3}$	V'1 = <input type="checkbox"/> V'2 = <input type="checkbox"/> V'3 = <input type="checkbox"/> V'd = <input type="checkbox"/>
Sepam B83: additional residual voltage input connection	Secondary injection of the rated phase-to-neutral voltage of VTs in an open delta arrangement ($U'_{np}/\sqrt{3}$ or $U'_{np}/3$)	Rated primary phase-to-neutral voltage of additional VTs $U'_{np}/\sqrt{3}$	V'1 = <input type="checkbox"/>
Sepam C86: unbalance current input connections	Secondary injection of the CT rated current, i.e. 1 A, 2 A or 5 A	CT rated primary current	I'1 = <input type="checkbox"/> I'2 = <input type="checkbox"/> I'3 = <input type="checkbox"/> I'0 = <input type="checkbox"/>

3

Tests performed on:	Signatures
By:	
Comments:	
.....	
.....	
.....	

Troubleshooting assistance	142
Replacing the base unit	146
Maintenance tests	147

Nothing happens when Sepam is switched on:

- all LEDs off
- nothing displayed on Sepam display.

There is probably an auxiliary power fault.

Possible cause	Action / remedy
Connector A not plugged in.	Plug in connector A.
Connectors A and E reversed.	Put connectors in correct positions.
Auxiliary power absent.	Check the auxiliary power level (range = 24 V DC to 250 V DC).
Polarities reversed on terminals 1 and 2 of connector A.	Check that the + polarity is on terminal 1 and the – polarity on terminal 2. Correct if necessary.
Internal problem.	Change base unit (see page 146)

Compatibility of Sepam version/SFT2841 version

The About SFT2841 screen indicates the minimum version of the SFT2841 software that is compatible with the Sepam being used.

To display this screen on the Sepam UMI:

- Press the  button.
 - Select the General menu.
 - The About SFT2841 screen can be found just after the About Sepam screen.
- Check that the SFT2841 software version you are using is higher than or the same as that indicated on the Sepam screen.

If the SFT2841 software version is lower than the minimum version compatible with the Sepam being used, the SFT2841 software cannot be connected to Sepam and the SFT2841 software displays the following error message: SFT2841 software version incompatible with the connected device.

DPER0204

About SFT2841

Please use SFT2841

 ≥ 10.0

SFT2841 compatible version screen.



Major faults are only cleared after the cause of the fault is corrected and Sepam is switched on again.

MAJOR fault: Sepam is in fail-safe position

- ON LED of UMI on in front
- LED of UMI on in front
- or LED of DSM303 remote advanced UMI flashing
- green LED on rear panel on
- red LED on rear panel on.

Note : The list of self-tests which place Sepam in the fail-safe position can be found in the Control and monitoring functions section of the Sepam series 80 function user's manual , reference SEPED303001EN.

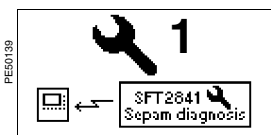

Fault message on display: major fault

Connection cannot be made with SFT2841	
Possible cause	Action / remedy
Memory cartridge absent.	Switch off Sepam. Install the memory cartridge and secure it by tightening the 2 integrated screws. Switch Sepam on again
Major internal fault.	Change base unit (see page 146).

Connection can be made with SFT2841	
Possible cause	Action / remedy
SFT2841 indicates major fault, but no missing module: Base unit internal fault.	Change base unit.
Memory cartridge not compatible with version of the base unit (see below).	Note the version using the SFT2841 software, Diagnosis screen. Contact the local support team.
The hardware configuration is incorrect or incomplete.	Use the SFT2841 software, in connected mode, to determine the cause. The SFT2841 Diagnosis screen displays the missing items in red (see table below).

Check on hardware configuration using SFT2841		
Diagnosis screen	Possible cause	Action / remedy
CCA630, CCA634, CCA671 or CCA640 connector in B1 or B2 position displayed in red.	Connector absent.	Install a connector. If the connector is present, check that it is plugged in correctly and held in place by the 2 screws.
	LPCT sensors not connected.	Connect the LPCT sensors.
Connector in position E displayed in red.	Connector E unplugged or no jumper between terminals 19 and 20.	Plug in connector E. Fit the jumper.
MES120 module in H1, H2 or H3 position displayed in red.	MES120 module absent.	Install MES120 module. If the MES120 module is present, check that it is plugged in correctly and held in place by the 2 screws. If the fault is still present, replace the module.

Rules on compatibility between the cartridge and the base unit

The major index of the base-unit version must be greater than or equal to the major index of the cartridge-application version.

Example: The base unit with a version V1.05 (major index = 1) and an application with a version V2.00 (major index = 2) are not compatible.

If this rule is not observed, a major fault occurs and Sepam displays the message opposite.



Fault message displayed if cartridge is not compatible.

MINOR fault: Sepam is operating in downgraded mode

- ON LED of UMI on in front
-  LED of UMI flashing in front
- green LED on rear panel on
- red LED on rear panel flashing.

Note : The list of self-tests which place Sepam in downgraded operation mode can be found in the Control and monitoring functions section of the function user's manual Sepam series 80, reference SEPED303001EN.

Inter-module link fault	
Possible cause	Action / remedy
Faulty wiring.	Check remote module connections: RJ45 plugs of CCA77x cords clipped correctly into sockets.

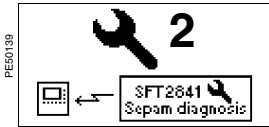

Fault message on display: inter-module link fault.

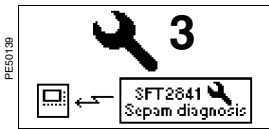

Fault message on display: MET148-2 not available.

MET148-2 module not available		
LEDs	Possible cause	Action / remedy
MET148-2 green and red LEDs off.	Faulty wiring.	Check module connections: RJ45 plugs of CCA77x cords clipped correctly into sockets.
MET148-2 green LED on. MET148-2 red LED off.	No response from MET148-2 module.	Check the position of the module number selection jumper: <ul style="list-style-type: none"> ■ MET1 for first MET148-2 module (temperatures T1 to T8) ■ MET2 for second MET148-2 module (temperatures T9 to T16). ■ If the jumper position needs to be changed, reboot the MET148-2 module (by disconnecting and reconnecting the interconnection cord).
MET148-2 red LED flashing.	Faulty wiring, MET148-2 powered but loss of dialogue with base unit.	Check module connections: RJ45 plugs of CCA77x cords clipped correctly into sockets. If the MET148-2 module is the last in the chain, check that the line terminating jumper is in the Rc position. In all other cases, the jumper should be in the position marked Rc .
MET148-2 red LED on.	More than 3 remote modules connected to connector D1 or D2 on base unit.	Distribute remote modules between D1 and D2.
	MET148-2 module internal fault.	Change MET148-2 module.

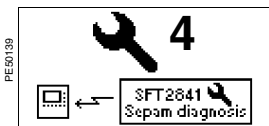

Fault message on display: MSA141 not available.

MSA141 module not available		
LEDs	Possible cause	Action / remedy
MSA141 green and red LEDs off.	Faulty wiring, MSA141 not powered.	Check module connections: RJ45 plugs of CCA77x cords clipped correctly into sockets.
MSA141 green LED on. MSA141 red LED flashing.	Faulty wiring, MSA141 powered but loss of dialogue with base unit.	Check module connections: RJ45 plugs of CCA77x cords clipped correctly into sockets. If the MSA141 module is the last in the chain, check that the line terminating jumper is in the Rc position. In all other cases, the jumper should be in the position marked Rc .
MSA141 red LED on.	More than 3 remote modules connected to connector D1 or D2 on base unit.	Distribute remote modules between D1 and D2.
	MSA141 module internal fault.	Change MSA141 module.

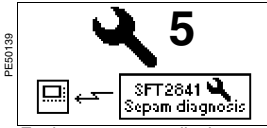

Fault message on display:
MCS025 not available.

MCS025 module not available		
LEDs	Possible cause	Action / remedy
MCS025 LED flashing.	Faulty wiring, MCS025 powered but loss of dialogue with base unit.	Check that a CCA785 cord is used with orange RJ45 plug on MCS025 end. Check module connections: RJ45 plugs of CCA785 cord clipped correctly into sockets.
MCS025 LED on.	Internal fault or MCS025 fault.	Check connections (DPC function - detection of plugged connector).

DSM303 module not available		
LEDs	Possible cause	Action / remedy
DSM303 LED on and display off.	Module internal fault.	Replace the DSM303 module.

Faulty Sepam UMI		
Display	Possible cause	Action / remedy
Advanced or mimic-based UMI display off.	Display internal fault.	Replace the base unit. See page 146.

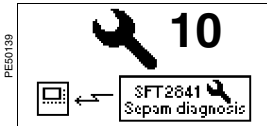

Fault message on display:
CPU overload.

Detection of Sepam CPU overload	
Possible cause	Action / remedy
The application configured exceeds the CPU capacity of the Sepam series 80.	Reduce the size of the Logipam program used on the Sepam series 80, or switch off some protection functions. For further information, contact your local support center.

Alarms

"METx FAULT" message.

RTD fault	
Possible cause	Action / remedy
An RTD on a MET148-2 module is disconnected or short-circuited.	Since the alarm is common to the 8 channels of the module, go to the temperature measurement display screen to determine which channel is affected by the fault. Measurement displayed: Tx.x = -**** = RTD disconnected (T > 205 °C (401 °F)) Tx.x = **** = RTD short-circuited (T < -35 °C (-31 °F))

"BATTERY LOW" message.

Battery fault	
Possible cause	Action / remedy
Battery low, absent or incorrectly installed.	Replace the battery. See page 146.

Replacing the base unit

Replacing the battery

PE80024

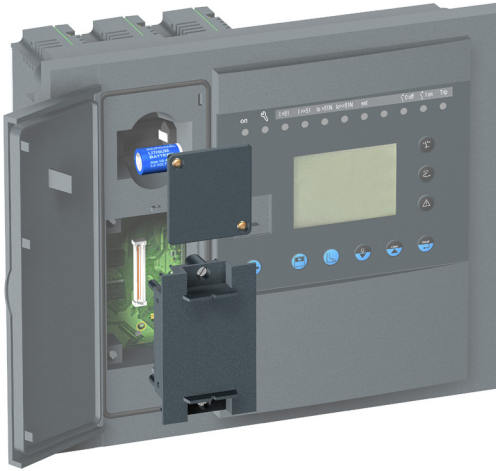

Memory cartridge accessed from the front.

Replacing the base unit

The memory cartridge is easily accessible and can be removed from the front of Sepam. It reduces the duration of maintenance operations.

When a base unit fails, simply:

1. Switch off Sepam and unplug connectors
2. Remove the memory cartridge
3. Replace the faulty base unit with a replacement unit (no memory cartridge) put the memory cartridge in the new base unit
4. Plug in the connectors and switch Sepam on again.

If there are no compatibility problems (see page 143), Sepam is operational with all its standard and customized functions, without requiring any reloading of protection and parameter settings.

Replacing the battery

Characteristics

1/2AA format 3.6 V, 0.8 Ah lithium battery

Recommended models:

- SAFT model LS14250
- SONNENSCHNEIN model SL-350/S

Recycling the battery

The used battery should be sent to a certified recycling company in compliance with the European Directive 91/157/EEC OJ L78  dated 26.03.91 on batteries and accumulators containing certain dangerous materials, modified by directive 98/101/EEC OJ L1 dated 05.01.1999.

Replacement

1. Lift off the protective battery cover after removing both fixing screws.
2. Change the battery, being sure to use the correct type and polarity.
3. Replace the protective battery cover and both fixing screws.
4. Recycle the used battery.

Note : The battery can be replaced with the Sepam energized.

⚠ DANGER**HAZARD OF ELECTRIC SHOCK, ELECTRIC ARC OR BURNS**

■ Only qualified personnel should maintain this equipment. Such work should be performed only after reading this entire set of instructions.

■ NEVER work alone.

■ Obey all existing safety instructions when commissioning and maintaining high-voltage equipment.

■ Beware of potential hazards and wear personal protective equipment.

Failure to follow these instructions will result in death or serious injury.

General

The logic inputs and outputs and the analog inputs are the parts of Sepam least covered by the self-tests. (The list of Sepam self-tests can be found in the Control and monitoring functions section of the Sepam series 80 function user's manual, reference SEPED303001EN).

They should be tested during a maintenance operation.

The recommended interval between preventive maintenance operations is 5 years.

Maintenance tests

To perform maintenance on Sepam, see Section 3, page 114. Carry out all the recommended commissioning tests according to the type of Sepam to be tested, except for the test specific to the differential function which is not necessary. If the MCS025 Synchro-check module is present, test its voltage inputs as well.

First test all the logic inputs and outputs involved in tripping the circuit breaker.

A test of the complete chain including the circuit breaker is also recommended.

Notes

4

Schneider Electric Industries SAS

89, boulevard Franklin Roosevelt
F - 92505 Rueil-Malmaison Cedex(France)
Tel : +33 (0)1 41 29 85 00
<http://www.schneider-electric.com>

As standards, specifications and designs change from time to time, please ask for confirmation of the information given in this publication.



Printed on recycled paper.

Production: Sigma Kudos France
Publication: Schneider Electric
Printed: