

SHINANO KENSHI CORP.



STEPPING MOTORS
DC BRUSHLESS MOTORS
DC SERVO MOTORS

SKC
SHINANO KENSHI CORP.



Since its inception in 1918, Shinano Kenshi Co., Ltd. of Japan has found innovative and creative ways to meet the challenges set by its expanding customer base. Recognizing the economic globalization, Shinano Kenshi began to quickly open divisions in strategic locations across the world, establishing factories and sales offices in Asia and Europe, as well as the United States.

With the establishment of its U.S. Sales and Engineering office in 1982, SKC-Shinano Kenshi Corporation began to rapidly open markets in the computer peripheral, medical, industrial and other motion control industries. As applications continue to demand higher performance and efficiency at increasingly competitive

prices, SKC raises its standard to become one of the leaders in its class. Our staff of talented individuals with diverse experience, along with a networked sales force across the U.S., strives to increase customer satisfaction through superior products and services, delivered on time at a competitive price.

This catalog is a compilation of standard models in a broad product line that demonstrates the scope of our commitment to motion control. In addition to the products described here, we have extensive custom design and manufacturing capability. Our technical support staff will be pleased to help you in finding the optimal solution to your motion control requirements.

ISO-9000 &
ISO-14000
Certified



CONTENTS

STEPPING MOTORS

Stepping Motor Operation & Theory	4
Holding Torque Range Chart	10
SST39C/40C Series	12
SST39D Series	14
SST42D Series	16
SLC42H Series	17
SST55D Series	18
STH56D Series	21
SST57D Series	22
SST58D Series	24
SST83D Series	27
5 Phase SST39A Series	28
5 Phase SST60B Series	29
Step Motor Driver Information	30

DC BRUSHLESS MOTORS

Model DR-24312-001E	31
Model DR-29306-051	32
Model DR-4312-007D	33
Model DR-4834-251	34
Model DR-5236-271	35
Model DR-5238-007	36
Model DR-538-504	37
Model DR-6236-152	38
Model DR-6634-514	39
Model DR-8538	40
Model DR-8738-252	41

DC SERVO MOTORS

LA Brushless Series	42
DH High Performance Series	44
DX Standard Series	49
Conversion Tables	51

SKC Stepping Motor Part Number

- Stepping motor model number description - SKC's stepping motor model number is determined by the following:

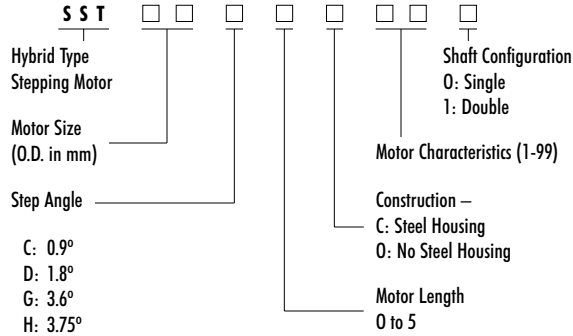

Lead Wire Configuration and Color Guide

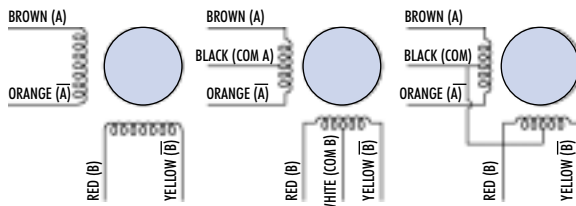

Typical Drive Circuits

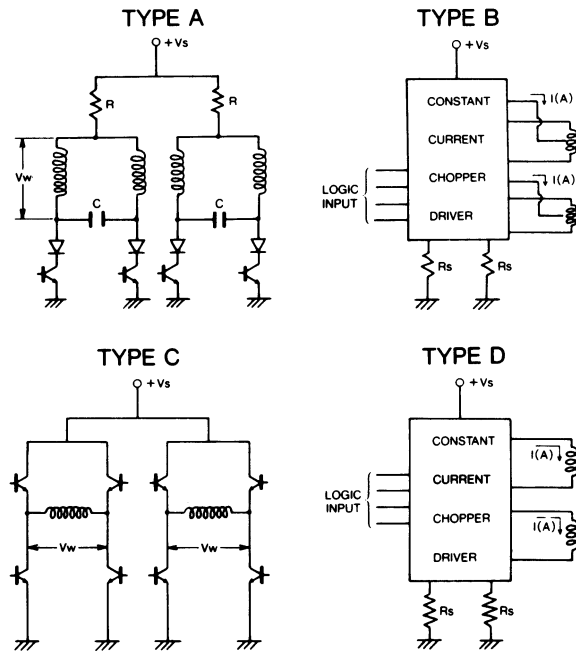

Features of Stepping Motors

- Rotational speed is proportional to the frequency of input pulses (stepping rate).
- Digital control of speed and position.
- Open loop system with no position feedback required.
- Excellent response to acceleration, deceleration and step commands.

- Noncumulative positioning error ($\pm 5\%$ of step angle).
- Excellent low speed/high torque characteristics without gear reduction.
- Inherent detent torque.
- Holding torque when energized.
- Bidirectional operation.
- Can be stalled without motor damage.
- No brushes for longer trouble free life.
- Precision ball bearings.

Typical Stepping Motor Applications

For accurate positioning of X-Y tables, plotters, printers, facsimile machines, medical applications, robotics, barcode scanners, image scanners, copiers, etc.

Construction

There are three basic types of step motors: variable reluctance (VR), permanent magnet (PM) and hybrid. SKC adopted the hybrid type step motor design because it has some of the desirable features of both the VR and PM. It has high resolution, excellent holding and dynamic torque and can operate at high stepping rate.

In Fig. 5-1 construction of SKC stepping motor is shown.

In Fig. 5-2 the detail of rotor construction is shown.

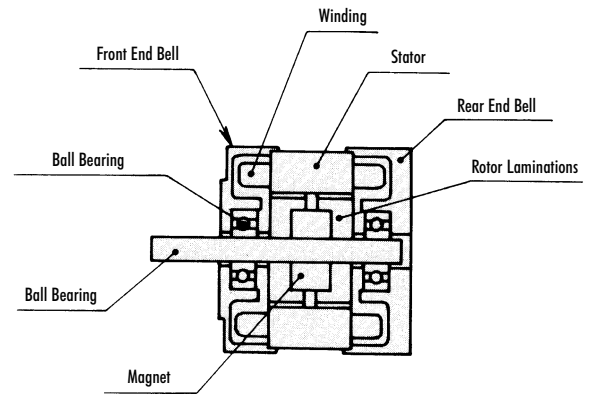

Fig. 5-1 Stepping Motor Construction

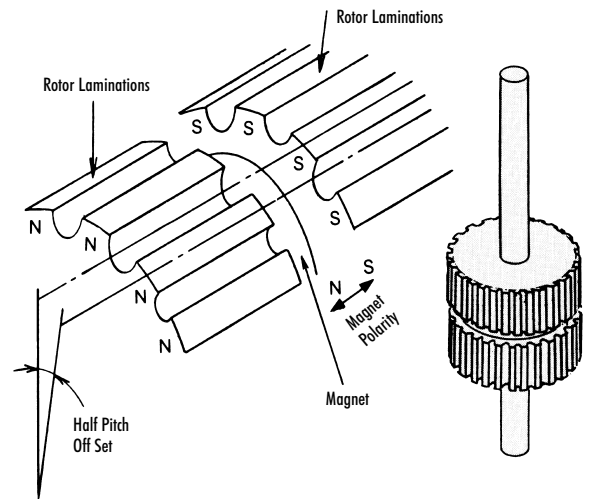

Fig. 5-2 Rotor Construction

Stepping Motor Theory

Using a 1.8 degree, unipolar, 4-phase stepping motor as an example, the following will explain the theory of operation. Referring to Fig. 6-1, the number of poles on the stator is 8 spaced at 45 degree intervals. Each pole face has 5 teeth spaced at 7.2 degree intervals. Each stator pole has a winding as shown in Fig. 6-1.

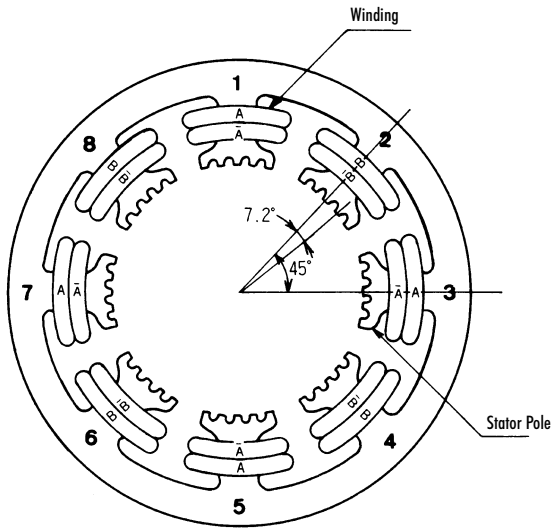
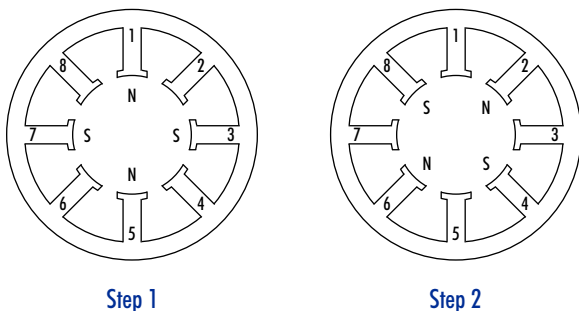

Fig. 6-1 Stator

When applying the current to the windings in the following sequence per Table 6-1, the stator can generate the rotating magnetic field as shown in Fig. 6-2 (steps 1 thru 4).

Drive Pulse	
Phase A	Step 1 ON OFF
Phase B	Step 2 ON OFF
Phase \bar{A}	Step 3 ON OFF
Phase \bar{B}	Step 4 ON OFF

Table 6-1 Step Phase Sequence (1 Phase Excited)



Step 1

Step 2

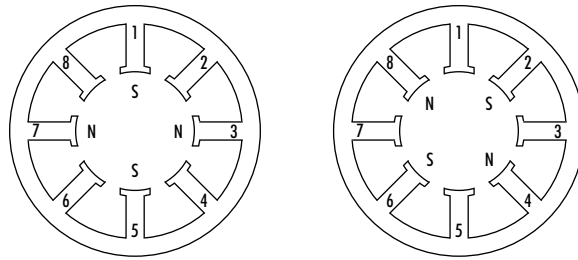

Fig. 6-2 Rotational Magnetic Field Generated by Phase Sequence

The hybrid rotor has 2 sets (stacks) of laminations separated by a permanent magnet. Each set of lams has 50 teeth and are offset from each other by 1/2 tooth pitch. This gives the rotor 50 N and 50 S poles at the rotor O.D.

Fig. 6-3 illustrates the movement of the rotor when the phase sequence is energized.

In step 1, phase A is excited so that the S pole of the rotor is attracted to pole 1,5 of the stator which is now a N pole, and the N pole of the rotor is attracted to pole 3,7 of the stator which is a S pole now. At this point there is an angle difference between the rotor and stator teeth of 1/4 pitch (1.8 degrees). For instance, the stator teeth of poles 2,6 and 4,8 are offset 1.8 degrees from the rotor teeth.

In step 2, there is a stable position when a S pole of the rotor is lined up with pole 2,6 of the stator and a N pole of the rotor lines up with pole 4,8 of stator. The rotor has moved 1.8 degrees of rotation from step 1.

The switching of phases per steps 3, 4 etc. produces 1.8 degrees of rotation per step.

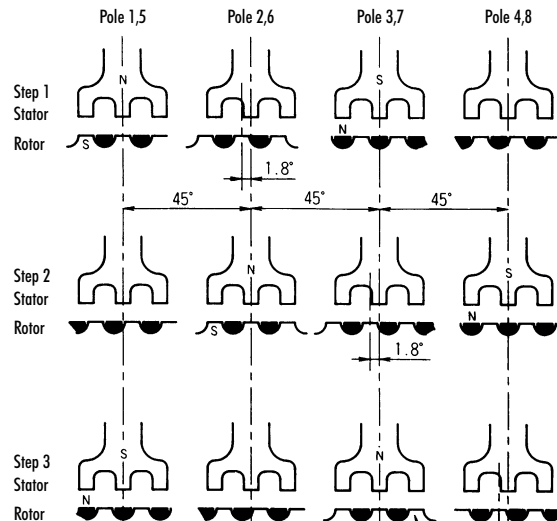

Fig. 6-3 1 Phase Excitation Sequence

■ Technical Data and Terminology

7-1 Holding Torque

The maximum steady torque that can be applied to the shaft of an energized motor without causing continuous rotation.

7-2 Detent Torque

The maximum torque that can be applied to the shaft of a non-energized motor without causing continuous rotation.

7-3 Speed-Torque Curve

The speed-torque characteristics of a stepping motor are a function of the drive circuit, excitation method and load inertia.

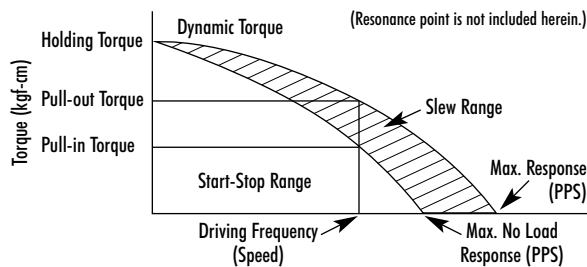

Fig. 7-1 Speed - Torque Curve

7-4 Maximum Slew Frequency

The maximum rate at which the step motor will run and remain in synchronism.

7-5 Maximum Starting Frequency

The maximum pulse rate (frequency) at which an unloaded step motor can start and run without missing steps or stop without taking more steps than pulses.

7-6 Pull-out Torque

The maximum torque that can be applied to the shaft of a step motor (running at constant speed) and not cause it to lose step.

7-7 Pull-in Torque

The maximum torque at which a step motor can start, stop and reverse the direction of rotation without losing step. The maximum torque at which an energized step motor will start and run in synchronism, without losing steps, at constant speed.

7-8 Slewing Range

This is the area between the pull-in and pull-out torque curves where a step motor can run without losing step, when the speed is increased or decreased gradually. Motor must be brought up to the slew range with acceleration and deceleration technique known as ramping.

7-9 Start-Stop Range

This is the range where a stepping motor can start, stop and reverse the direction of rotation without losing step.

7-10 Accuracy

This is defined as the difference between the theoretical and actual rotor position expressed as a percentage of the step angle. Standard is $\pm 5\%$. An accuracy of $\pm 3\%$ is available on special request. This positioning error is noncumulative.

7-11 Hysteresis Error

This is the maximum accumulated error from theoretical position for both forward and backward direction of rotation. See Fig 7-2.

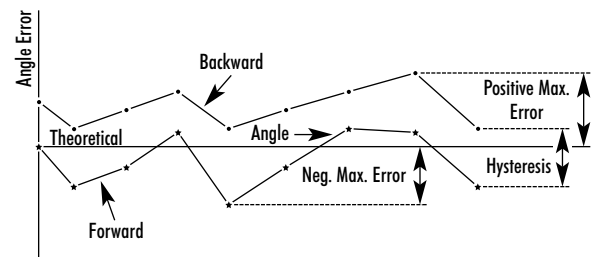

Fig. 7-2 Step Angle Accuracy

7-12 Resonance

A step motor operates on a series of input pulses, each pulse causing the rotor to advance one step. In this time the motor's rotor must accelerate and then decelerate to a stop. This causes ringing, overshoot and vibration. There are some speeds at which the motor will not run. This is called its resonant frequency. The objective is to design the system so that no resonant frequencies appear in the operating speed range. This problem can be eliminated by means of using mechanical dampers or external electronics.

■ Drive Methods

8-1 Drive Circuits

The operation of a step motor is dependent upon an indexer (pulse source) and driver. The indexer feeds pulses to the driver which applies power to the appropriate motor windings. The number and rate of pulses determines the speed, direction of rotation and the amount of rotation of the motor output shaft. The selection of the proper driver is critical to the optimum performance of a step motor. Fig. 8-1 shows some typical drive circuits.

These circuits also illustrate some of the methods used to protect the power switches against reverse voltage transients.

8-1-1 Damping Methods

These circuits can also be used to improve the damping and noise characteristics of a step motor. However, the torque at higher pulse rates (frequency) can be reduced so careful consideration must be exercised when selecting one of these methods.

Examples:

- 1. Diode Method Fig. 8-1 (a)
- 2. Diode + Resistance Method Fig. 8-1 (b)
- 3. Diode + Zener Diode Method Fig. 8-1 (c)
- 4. Capacitor Method Fig. 8-1 (d)

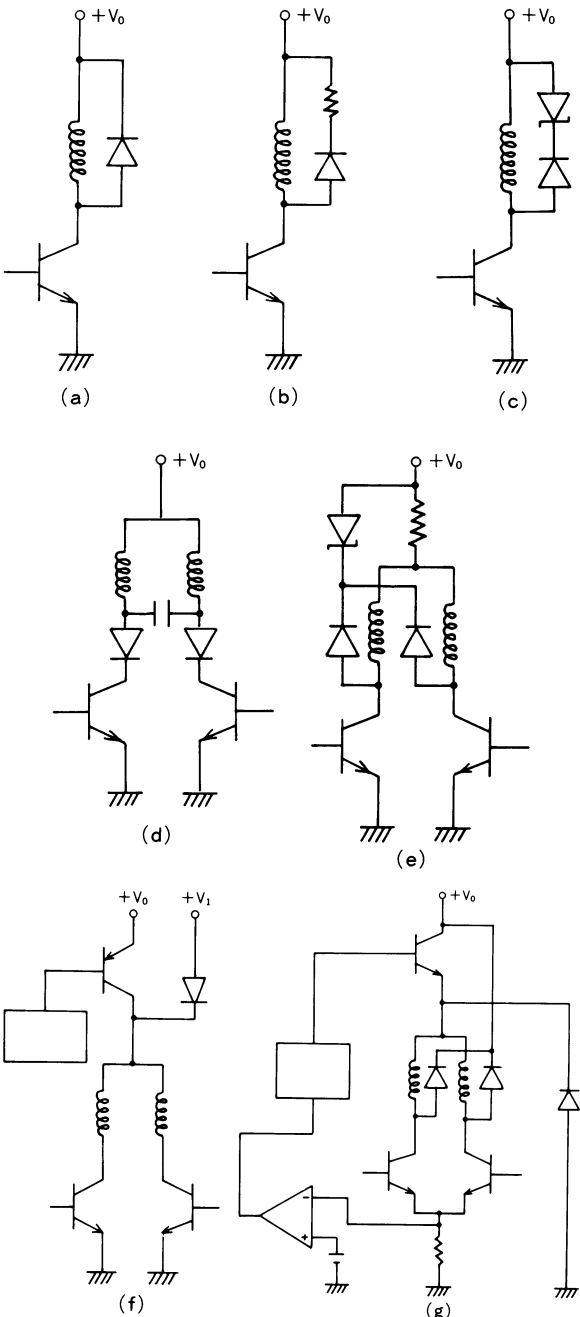

Fig. 8-1

8-1-2 Stepping Rate

A step motor operated at a fixed voltage has a decreasing torque curve as the frequency or step rate increases. This is due to the rise time of the motor winding which limits the value of the coil current. This is determined by the ratio of inductance to resistance (L/R) of the motor and driver as illustrated in Fig 8-2 (a).

Compensation for the L/R of a circuit can be accomplished as follows:

- a) Increase the supply voltage and add a series resistor, Fig 8-2 (b), to maintain rated motor current and reduce the L/R of the circuit.
- b) Increase the supply voltage, Fig 8-2 (c), improving the time constant (L/R) of the circuit. However, it is necessary to limit the motor current with a bi-level or chopped supply voltage.

Examples:

- 1. Constant Voltage Drive Fig. 8-1 (e)
- 2. Dual Voltage (Bi-level) Drive Fig. 8-1 (f)
- 3. Chopper Drive Fig. 8-1 (g)

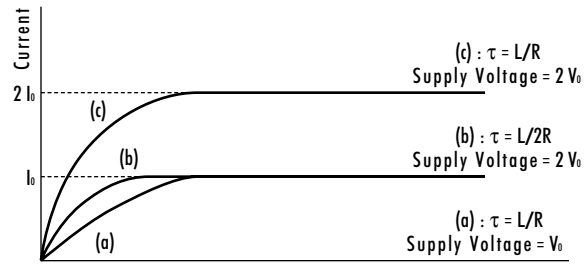

Fig. 8-2

Note: τ = Electrical Time Constant

8-2 Excitation Methods

In Table 8-1 are descriptions and features of each method.

		Excitation Method		
		Single Phase	Dual Phase	1-2 Phase
Switching sequence	Pulse			
	phase A			
	phase B			
	phase A phase B			
Features		Hold & running torque reduced by 39%. Increased efficiency. Poor step accuracy.	High torque Good step accuracy.	Poor step accuracy. Good resonance characteristics. Higher pulse rates. Half stepping

Table 8-1

8-3 Bipolar and Unipolar Operation

All SKC stepper motors are available with either two coil bipolar or four coil unipolar windings.

Bipolar Winding - the stator flux is reversed by reversing the current in the winding. It requires a push-pull bipolar drive as shown in Fig. 8-3. Care must be taken to design the circuit so that the transistors in series do not short the power supply by coming on at the same time. Properly operated, the bipolar winding gives the optimum performance at low to medium step rates.

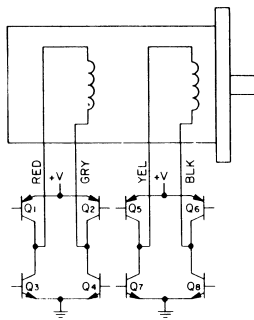

Fig. 8-3 Bipolar Method

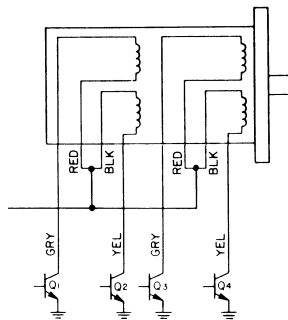

Fig. 8-4 Unipolar Method

Unipolar Winding - has two coils wound on the same bobbin per stator half. Flux is reversed by energizing one coil or the other coil from a single power supply. The use of a unipolar winding, sometimes called a bifilar winding, allows the drive circuit to be simplified. Not only are one-half as many power switches required (4 vs. 8), but the timing is not as critical to prevent a current short through two transistors as is possible with a bipolar drive. Unipolar motors have approximately 30% less torque at low step rates. However, at higher rates the torque outputs are equivalent.

Step Motor Load Calculations and Selection

To select the proper step motor, the following must be determined:

1. Load Conditions
 - 1-a. Friction Load
 - 1-b. Load Inertia
2. Dynamic Load Conditions
 - 2-a. Drive Circuit
 - 2-b. Maximum Speed (PPS/Frequency)
 - 2-c. Acceleration/Deceleration Pattern

With the above load information the proper step motor can be selected.

9-1 Load Inertia

The following is an example for calculating the inertia of a hollow cylinder.

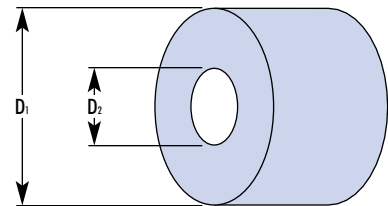

Fig. 9-1

$$J = \frac{1}{8} \cdot M \cdot (D_1^2 + D_2^2) \quad (\text{kg-cm}^2)$$

Where M: mass of pulley (kg)
D₁: outside diameter (cm)
D₂: inside diameter (cm)

9-2 Linear systems can be related to rotational systems by utilizing the kinetic energy equations for the two systems. For linear translations:

$$\text{Energy} = \frac{1}{2} M v^2 = \frac{1}{2} J \omega^2$$

Where M: mass
v: velocity
J: inertia
ω: angular velocity

1) Gear drive system

When gears are used to drive a load, the inertia reflected to the motor is expressed by the following equation:

$$J = (Z_1/Z_2)^2 \cdot (J_2 + J_3) + J_1$$

Where Z₁, Z₂: No. of gear teeth
J₁, J₂, J₃: inertia (kg-cm²)
J: reflected inertia, (kg-cm²)

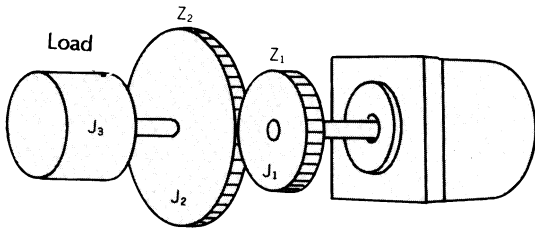

Fig. 9-2

2) Pulley & belt system. A motor and belt drive arrangement is used for linear load translation

$$J = 2 J_1 + \frac{1}{4} M D_2^2$$

Where J: Total inertia reflected to motor
 J₁: inertia of pulley (kg-cm²)
 D: diameter of pulley (cm)
 M: weight of load (kg)

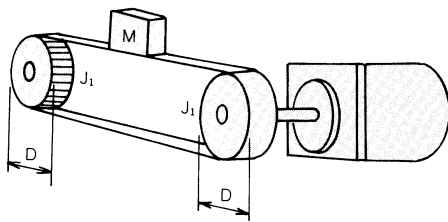

Fig. 9-3

9-3 Determination of load acceleration/deceleration pattern.

9-3-1 Load Calculation

To determine the torque required to drive the load the following equation should be satisfied.

$$T_m = T_f + T_i$$

Where: T_m: Pullout torque (kgf-cm)
 T_f: Friction torque (kgf-cm)
 T_i: Inertia load (kgf-cm)

$$T_i = (J_r + J_l)/g \cdot (\pi \cdot \theta \cdot s)/180 \cdot df/dt$$

J_r: Rotor inertia [kg-cm²]
 J_l: Load inertia [kg-cm²]
 θ: Step angle [deg]
 g: Gravity acceleration = 980 [cm/sec²]
 f: Drive frequency [PPS]

Example: A 1.8 degree step motor is to be accelerated from 100 to 1,000 pulses per second (PPS) in 50 ms, J_r = 100 g-cm², J_l = 1 kg-cm². The necessary pullout torque is:

$$T_i = (0.1 + 1)/980 \cdot (\pi \cdot 1.8)/180 \cdot (1000 - 100)/0.05 = 0.635 \text{ (kgf-cm)}$$

9-3-2 Linear acceleration

For linear acceleration as shown in Fig. 9-4 frequency f(t), inertial system frequency f_i(t) and inertia load T_i are expressed as follows:

$$f(t) = (f_1 - f_0)/t_1 \cdot t + f_0$$

$$T_i = (J_r + J_l)/g \cdot (\pi \cdot \theta \cdot s)/180 \cdot (f_1 - f_0)/t_1$$

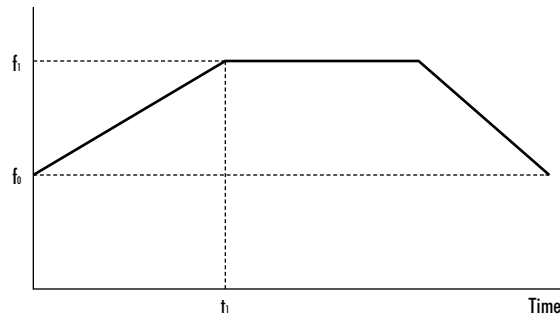

Fig. 9-4 Linear Acceleration

9-3-3 Exponential acceleration

For exponential as shown in Fig. 9-5, drive frequency f(t) and inertia load T_i are expressed as follows:

$$f(t) = f_1 \cdot (1 - e^{-(t/\tau)}) + f_0$$

$$T_i = (J_r + J_l)/g \cdot (\pi \cdot \theta \cdot s)/180 \cdot f_1/\tau \cdot e^{-(t/\tau)}$$

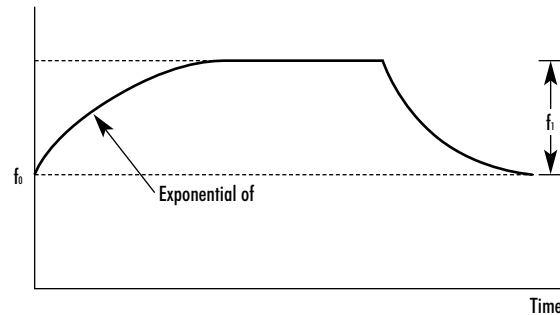
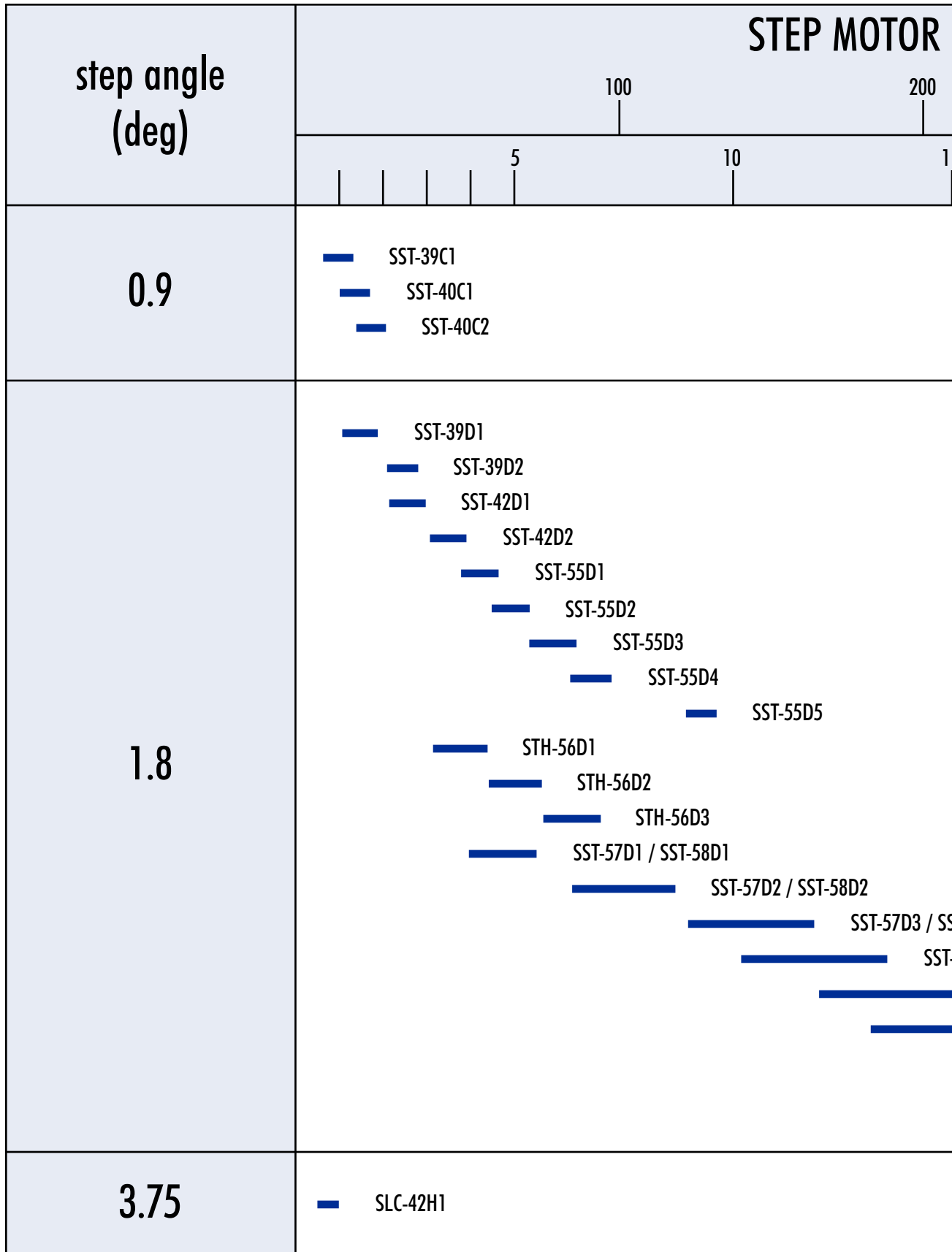
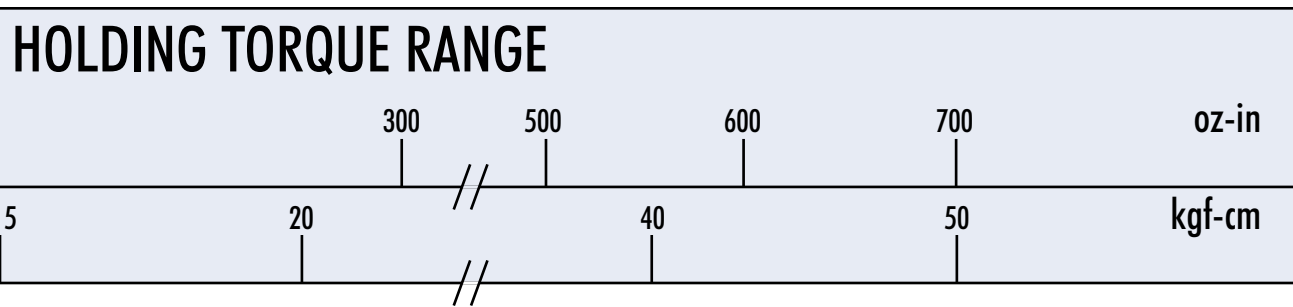

Fig. 9-5 Exponential Acceleration

HOLDING TORQUE





SST-58D3
SST-57D4 / SST-58D4
SST-57D5 / SST-58D5
SST-83D1

SST-83D2
SST-83D3

HOLDING TORQUE

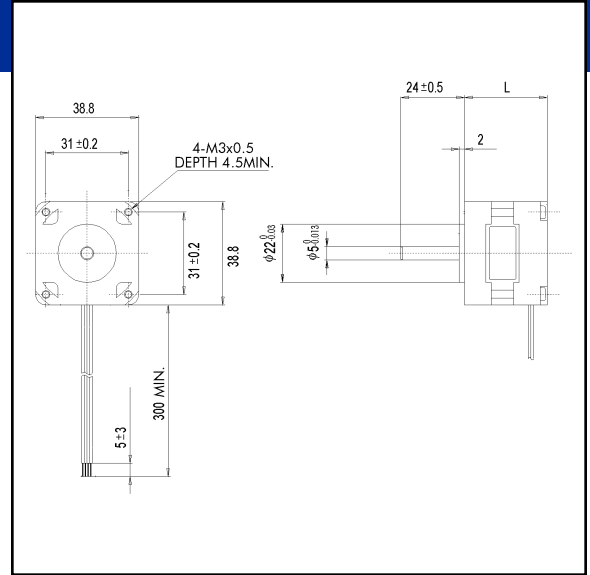
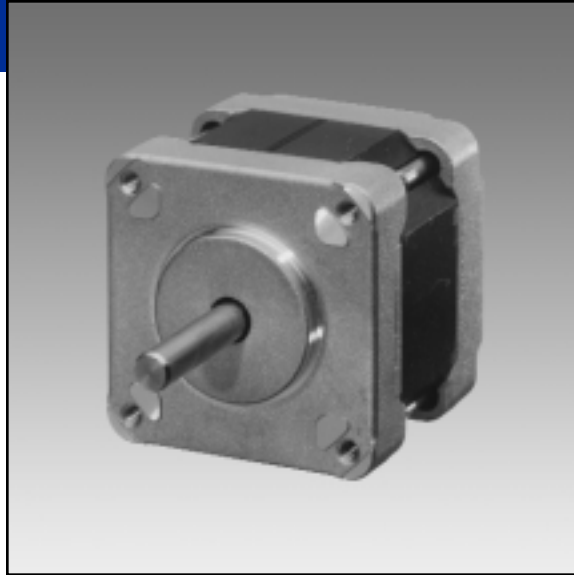

SPECIFICATION

MODEL		STEP ANGLE	VOLTAGE	CURRENT	RESISTANCE	INDUCTANCE	HOLDING TORQUE	ROTOR INERTIA	NUMBER OF LEADS	WEIGHT	DIMENSION
SINGLE SHAFT	DOUBLE SHAFT	DEG.	V	A/Phase	Ω /Phase	mH/Phase	kg-cm	g-cm ²	LEAD	kg	L
SST39C1010	SST39C1011	0.9	4	0.8	5	1.4	0.65	17	6	0.17	31
SST39C1020	SST39C1021	0.9	6	0.6	10	3	0.70	17	6	0.17	31
SST39C1030	SST39C1031	0.9	11	0.3	37.5	11	0.70	17	6	0.17	31
SST40C1010	SST40C1011	0.9	4	0.8	5	5	1.15	17	6	0.17	31
SST40C1020	SST40C1021	0.9	9.6	0.4	24	26	1.20	17	6	0.17	31
SST40C1030	SST40C1031	0.9	11.2	0.3	37.5	37.7	1.25	17	6	0.17	31
SST40C2010	SST40C2011	0.9	6	0.8	7.5	11	1.85	27	6	0.2	37
SST40C2020	SST40C2021	0.9	8.6	0.56	15	23	1.79	27	6	0.2	37
SST40C2030	SST40C2031	0.9	12	0.4	30	44	1.67	27	6	0.2	37

TYPICAL PERFORMANCE

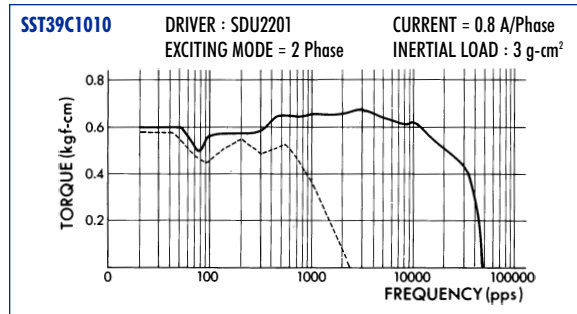

REFER TO PAGE 30 FOR DRIVER

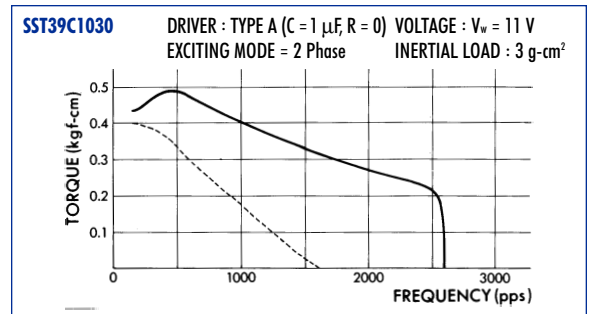
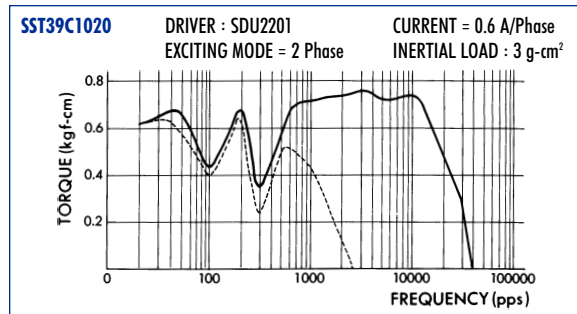
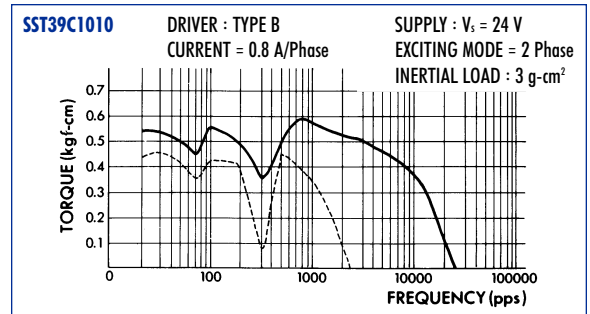

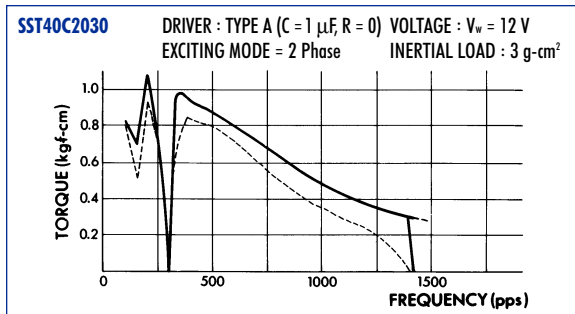
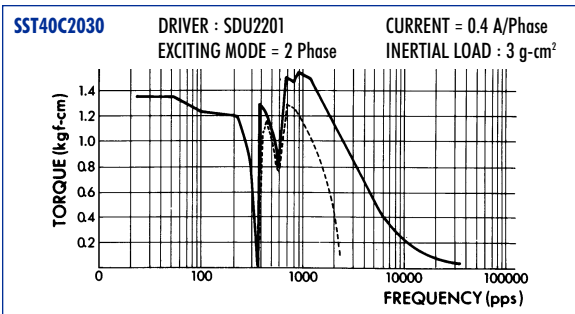
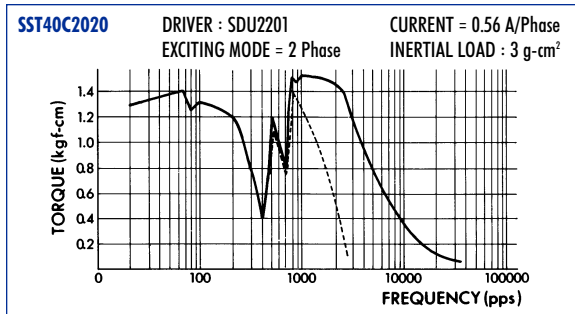
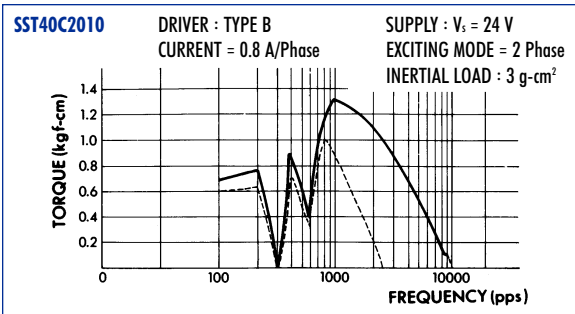
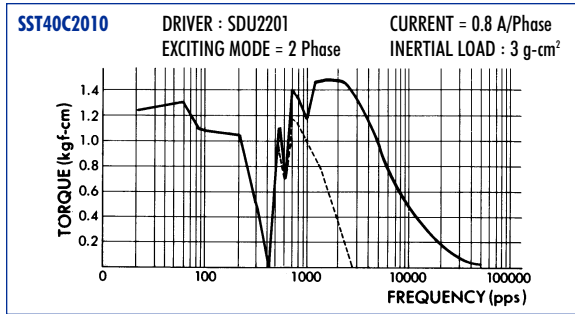
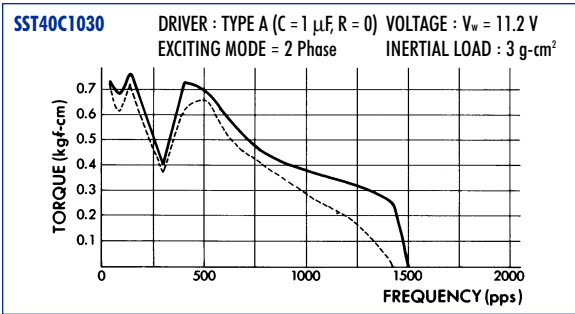
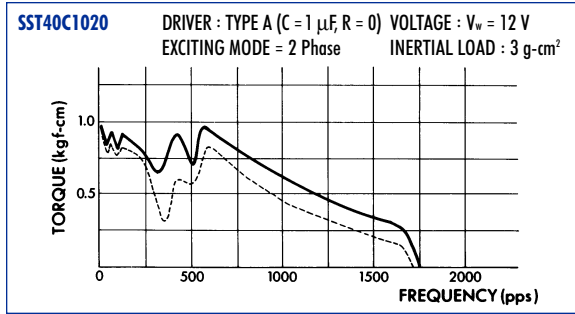
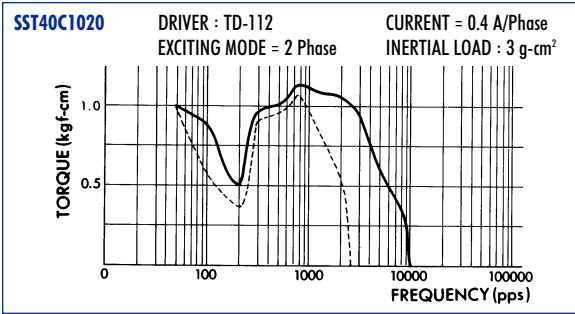
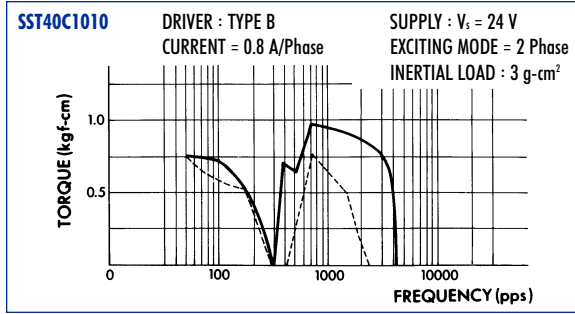
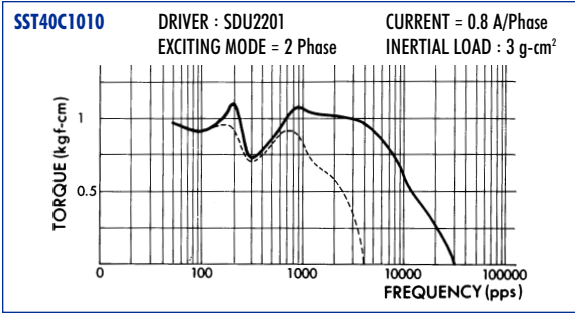

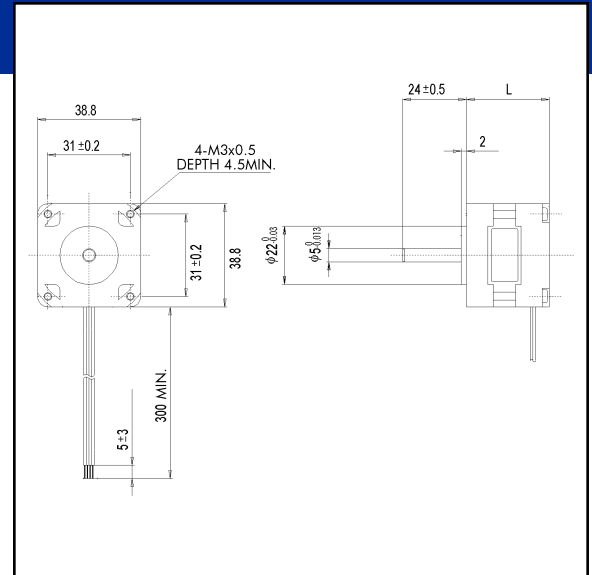
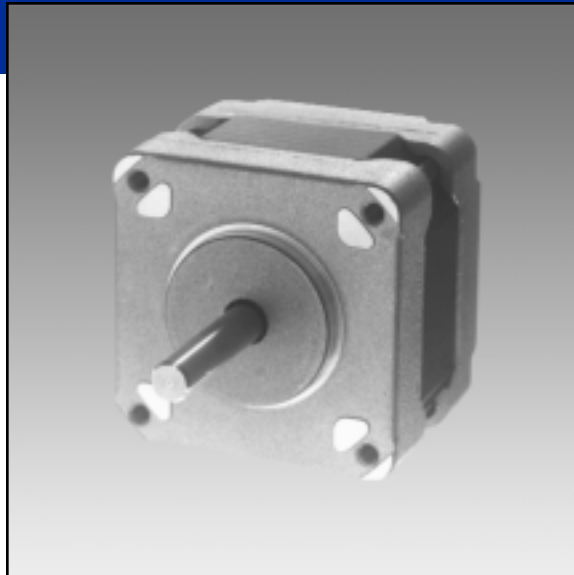

DIMENSIONS

SPECIFICATION

MODEL		STEP ANGLE	VOLTAGE	CURRENT	RESISTANCE	INDUCTANCE	HOLDING TORQUE	ROTOR INERTIA	NUMBER OF LEADS	WEIGHT	DIMENSION
SINGLE SHAFT	DOUBLE SHAFT	DEG.	V	A/Phase	Ω/Phase	mH/Phase	kg-cm	g-cm ²	LEAD	kg	L
SST39D1010	SST39D1011	1.8	4.3	0.85	5	5	1.48	17	6	0.17	31
SST39D1020	SST39D1021	1.8	9.6	0.4	24	21	1.38	17	6	0.17	31
SST39D1030	SST39D1031	1.8	8.3	0.22	37.5	30	0.98	17	6	0.17	31
SST39D1040	SST39D1041	1.8	12	0.16	75	60	1.0	17	6	0.17	31
SST39D1050	SST39D1051	1.8	4	0.95	4.2	4	1.1	17	6	0.17	31
SST39D2010	SST39D2011	1.8	6	0.8	7.5	7.5	2.2	27	6	0.2	37
SST39D2020	SST39D2021	1.8	8.5	0.56	15	16.5	2.4	27	6	0.2	37
SST39D2030	SST39D2031	1.8	12	0.4	30	30	2.4	27	6	0.2	37

TYPICAL PERFORMANCE

REFER TO PAGE 30 FOR DRIVER

— PULL OUT
- - - PULL IN

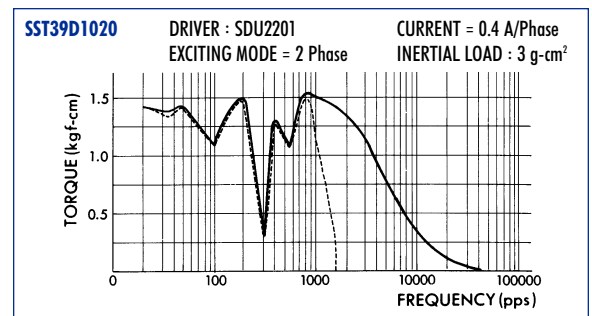
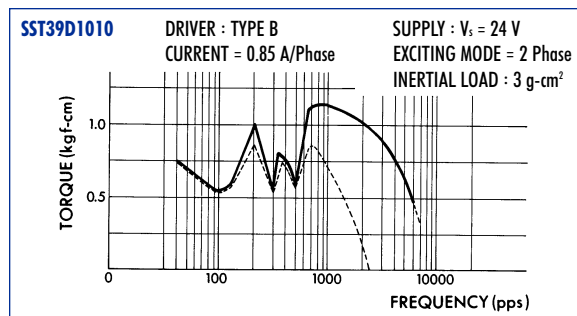
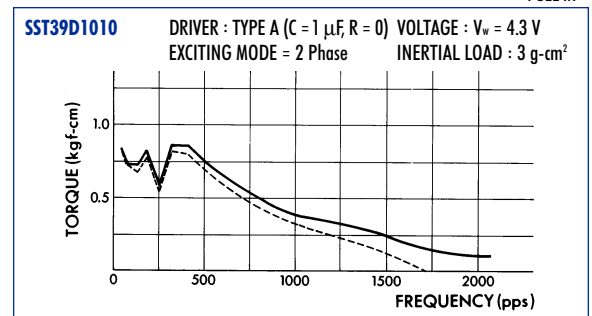
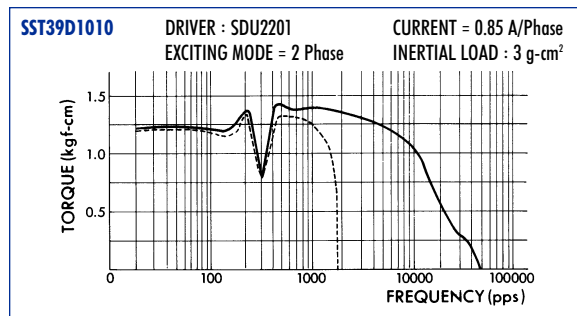

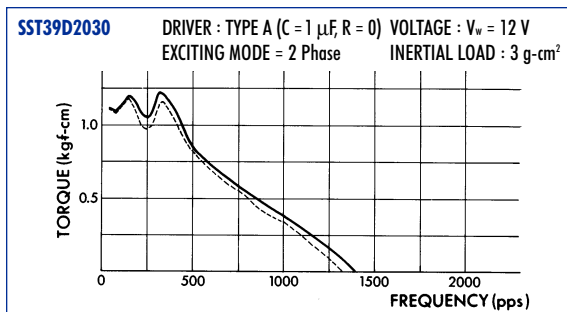
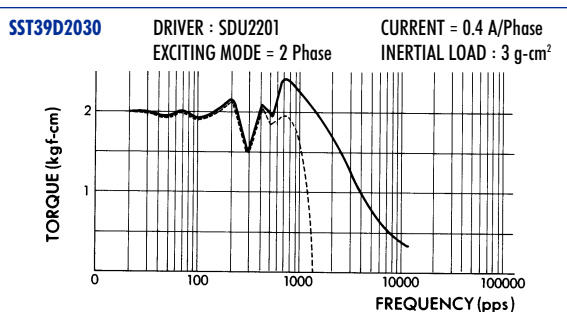
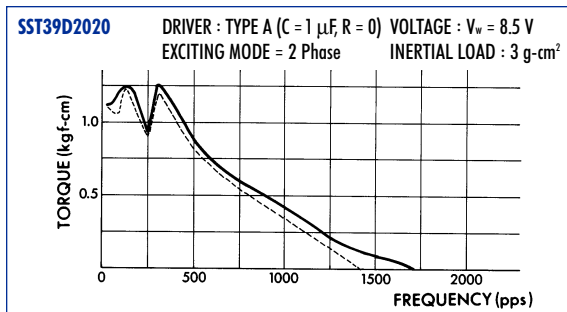
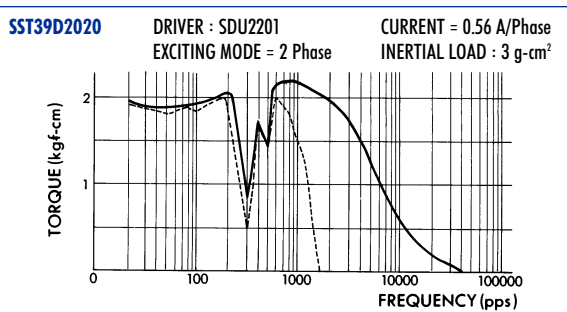
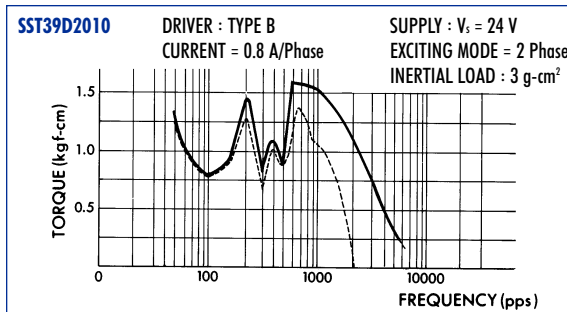
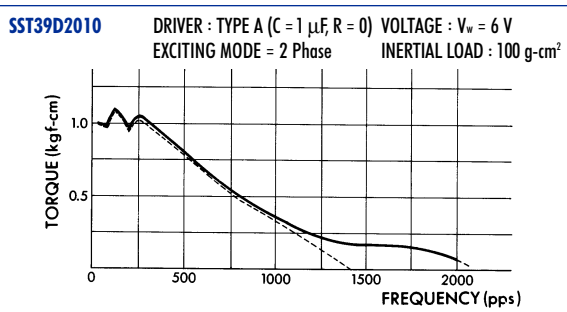
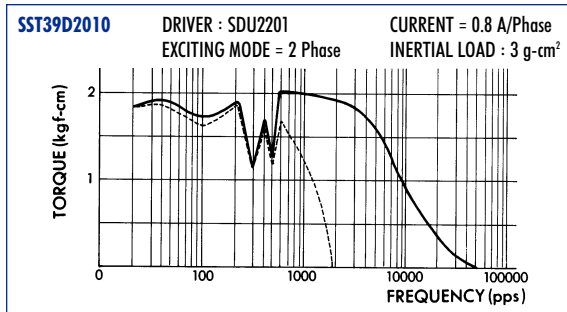
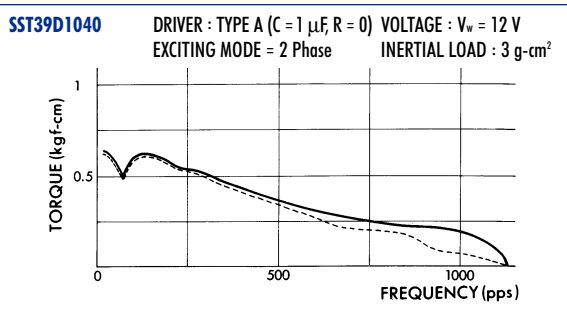
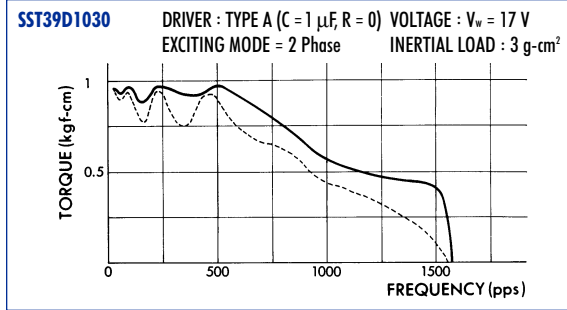
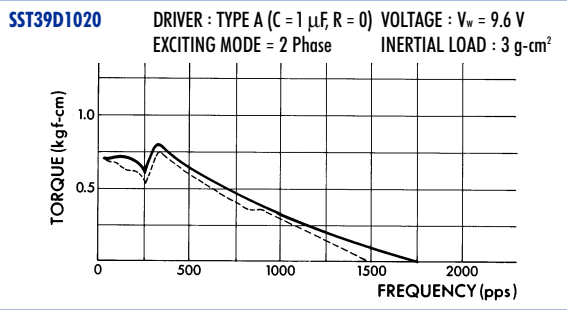

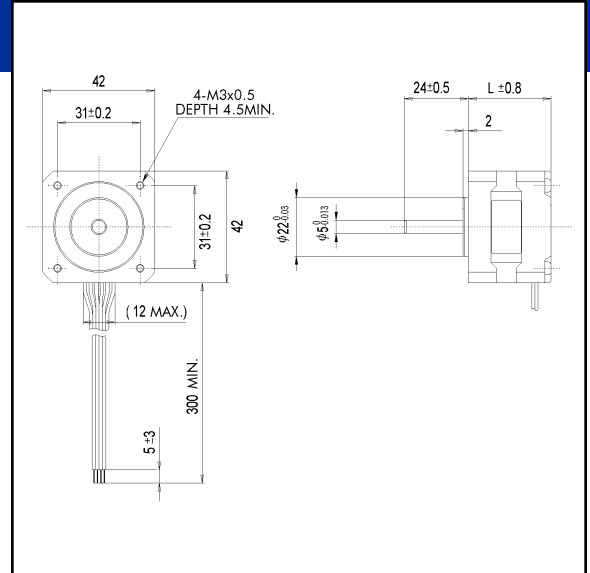
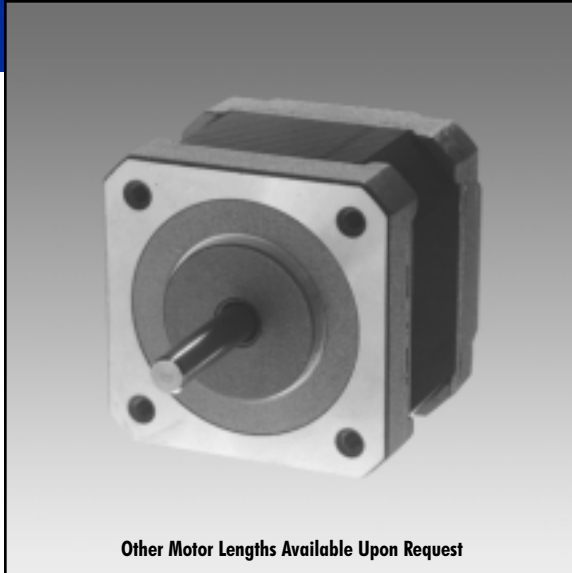

SPECIFICATION

MODEL		STEP ANGLE	VOLTAGE	CURRENT	RESISTANCE	INDUCTANCE	HOLDING TORQUE	ROTOR INERTIA	NUMBER OF LEADS	WEIGHT	DIMENSION
SINGLE SHAFT	DOUBLE SHAFT	DEG.	V	A/Phase	Ω/Phase	mH/Phase	kg-cm	g-cm ²	LEAD	kg	L
SST42D1100	SST42D1101	1.8	3.7	0.95	3.9	3.6	1.9	27	6	0.18	31
SST42D1070	SST42D1071	1.8	5.3	0.7	7.6	6.8	1.9	27	6	0.18	31
SST42D1040	SST42D1041	1.8	10.5	0.35	30	21.7	1.7	27	6	0.18	31
SST42D1020	SST42D1021	1.8	16.5	0.22	75	53.0	1.7	27	6	0.18	31
SST42D2120	SST42D2121	1.8	3.7	1.2	3.1	4.2	3.2	48	6	0.27	38
SST42D2090	SST42D2091	1.8	5.1	0.9	5.7	6.8	3.2	48	6	0.27	38
SST42D2070	SST42D2071	1.8	6.7	0.7	9.5	11.8	3.2	48	6	0.27	38
SST42D2040	SST42D2041	1.8	12.0	0.4	30	34.3	3.2	48	6	0.27	38
SST42D2030	SST42D2031	1.8	18.8	0.25	75	72.8	3.0	48	6	0.27	38

TYPICAL PERFORMANCE

REFER TO PAGE 30 FOR DRIVER

— PULL OUT
- - - PULL IN

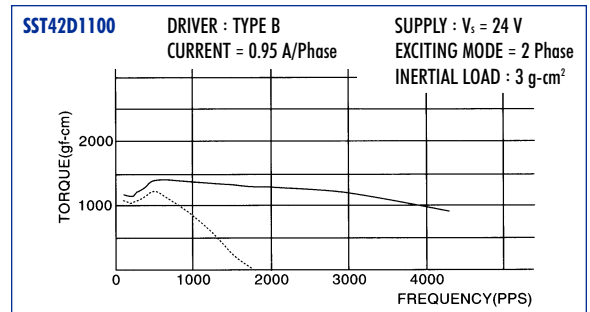
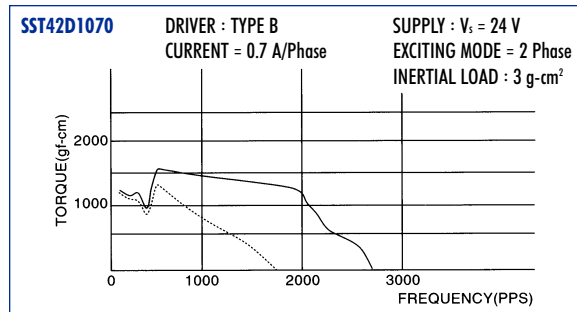
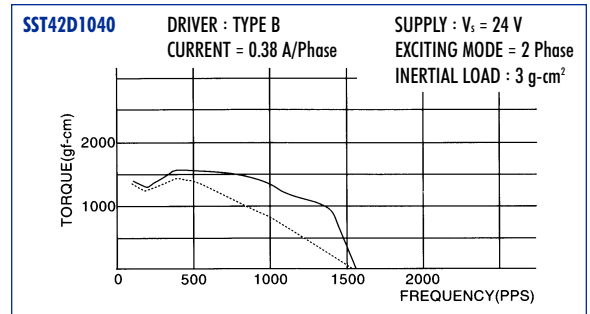
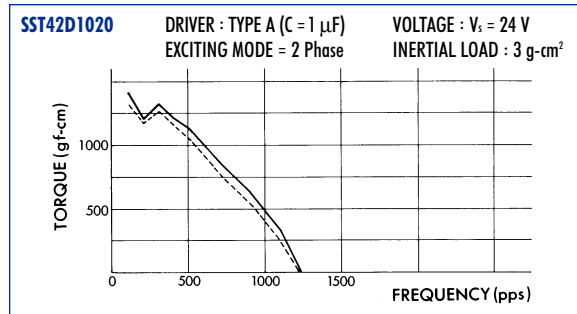

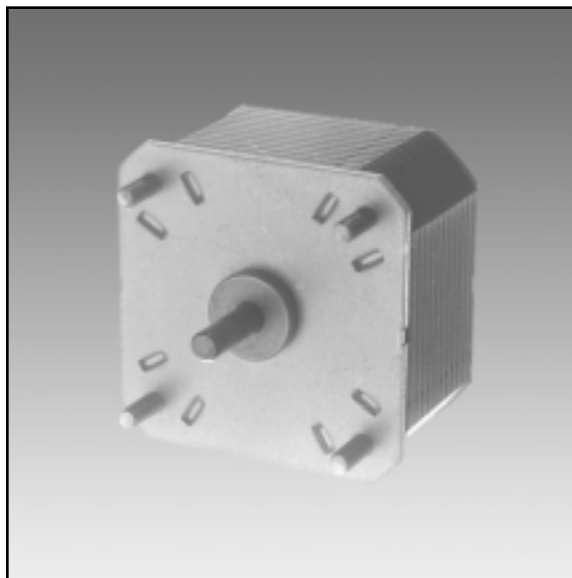
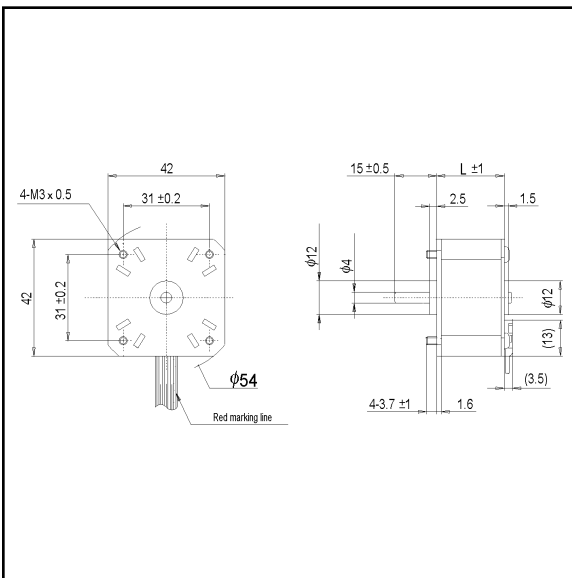
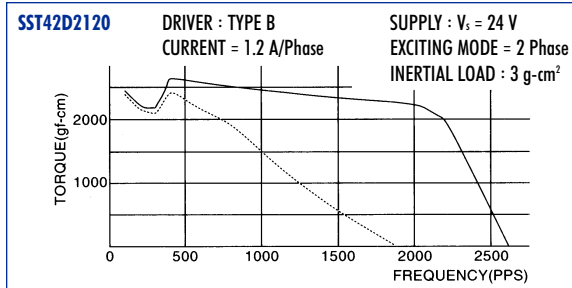
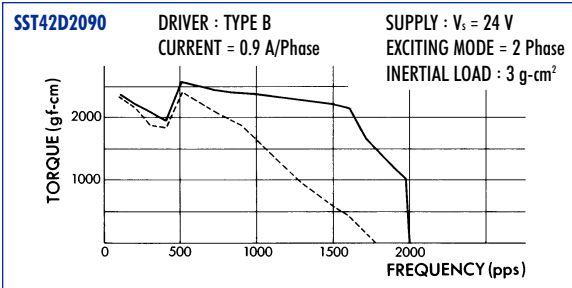
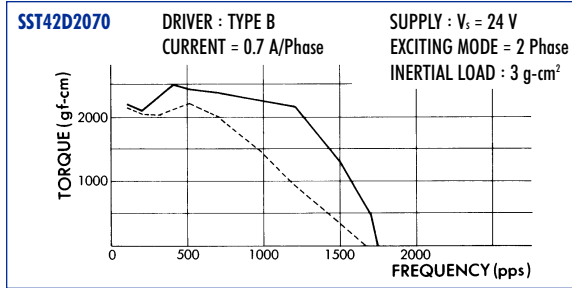
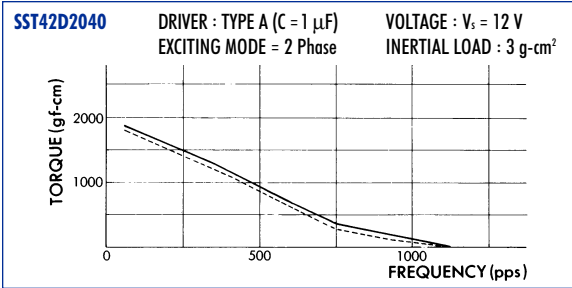

SPECIFICATION

MODEL	STEP ANGLE	VOLTAGE	CURRENT	RESISTANCE	INDUCTANCE	HOLDING TORQUE	ROTOR INERTIA	NUMBER OF LEADS	WEIGHT	DIMENSION
SINGLE SHAFT	DEG.	V	A/Phase	Ω /Phase	mH/Phase	kg-cm	g-cm ²	LEAD	kg	L
SLC42H1900	3.75	4.8	0.4	12	14	0.73	27	4	0.19	25

TYPICAL PERFORMANCE

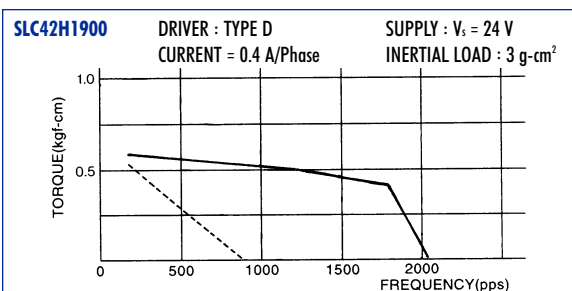

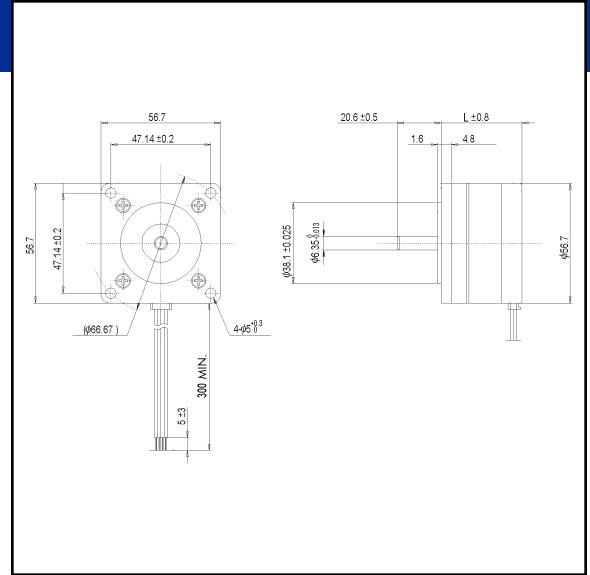
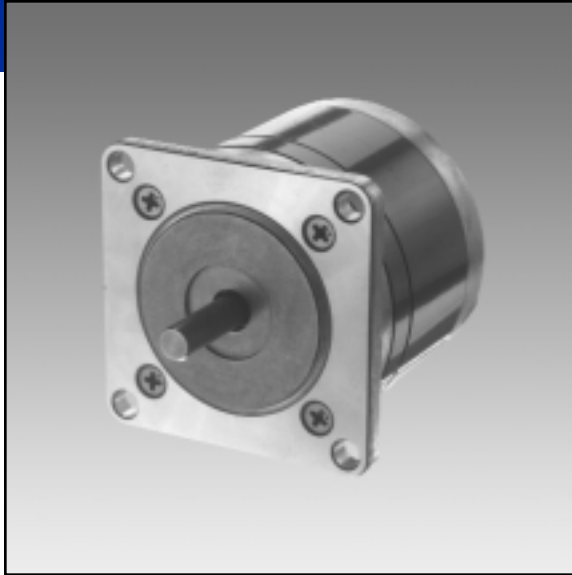

SPECIFICATION

MODEL		STEP ANGLE DEG.	VOLTAGE V	CURRENT A/Phase	RESISTANCE Ω /Phase	INDUCTANCE mH/Phase	HOLDING TORQUE kg-cm	ROTOR INERTIA g-cm ²	NUMBER OF LEADS LEAD	WEIGHT kg	DIMENSION L
SINGLE SHAFT (WITH CASE)	DOUBLE SHAFT (WITH CASE)										
SST55D1010 (SST55D1C010)	SST55D1011 (SST55D1C011)	1.8	2.6	1.7	1.5	1.9	3.0	55	6	0.34 (0.38)	38
SST55D1020 (SST55D1C020)	SST55D1021 (SST55D1C021)	1.8	4	1.1	3.6	4.8	3.3	55	6	0.34 (0.38)	38
SST55D1030 (SST55D1C030)	SST55D1031 (SST55D1C031)	1.8	12	0.4	30	31.5	2.9	55	6	0.34 (0.38)	38
SST55D1040 (SST55D1C040)	SST55D1041 (SST55D1C041)	1.8	24	0.2	120	92	2.6	55	6	0.34 (0.38)	38
SST55D2010 (SST55D2C010)	SST55D2011 (SST55D2C011)	1.8	1.6	3.2	0.5	0.63	4.45	100	6	0.47 (0.51)	49.5
SST55D2020 (SST55D2C020)	SST55D2021 (SST55D2C021)	1.8	5	1.0	5	9.0	5.0	100	6	0.47 (0.51)	49.5
SST55D2030 (SST55D2C030)	SST55D2031 (SST55D2C031)	1.8	9	0.56	16	24	4.75	100	6	0.47 (0.51)	49.5
SST55D2040 (SST55D2C040)	SST55D2041 (SST55D2C041)	1.8	24	0.22	110	120	4.55	100	6	0.47 (0.51)	49.5
SST55D3010 (SST55D3C010)	SST55D3011 (SST55D3C011)	1.8	3.3	2.2	1.5	2.8	6.8	160	6	0.55 (0.61)	55.5
SST55D3020 (SST55D3C020)	SST55D3021 (SST55D3C021)	1.8	6	1.2	5	10	6.5	160	6	0.55 (0.61)	55.5
SST55D3030 (SST55D3C030)	SST55D3031 (SST55D3C031)	1.8	12	0.6	20	39	6.9	160	6	0.55 (0.61)	55.5
SST55D3040 (SST55D3C040)	SST55D3041 (SST55D3C041)	1.8	24	0.3	80	99	6.2	160	6	0.55 (0.61)	55.5
(SST55D4C010)	(SST55D4C011)	1.8	5.1	1.4	3.6	5.4	7.3	200	6	(0.77)	66.5
(SST55D5C010)	(SST55D5C011)	1.8	4	2	2	3.5	9.6	220	6	(0.94)	76.5
(SST55D5C020)	(SST55D5C021)	1.8	5	1.5	3.3	5.9	9.4	220	6	(0.94)	76.5

TYPICAL PERFORMANCE

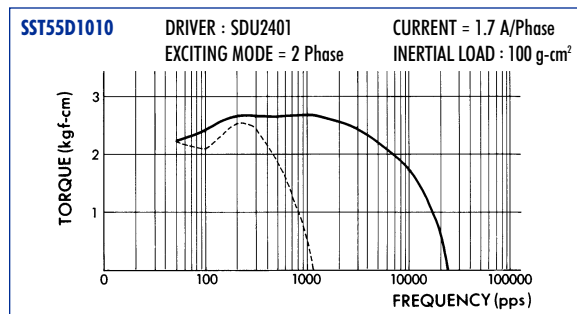

REFER TO PAGE 30 FOR DRIVER

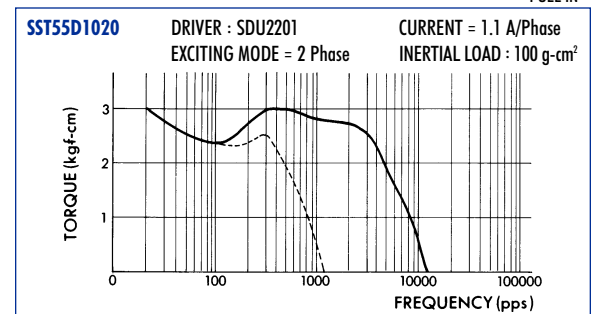

SST55D1030 DRIVER : SDU2201 CURRENT = 0.4 A/Phase
EXCITING MODE = 2 Phase INERTIAL LOAD : 100 g-cm²

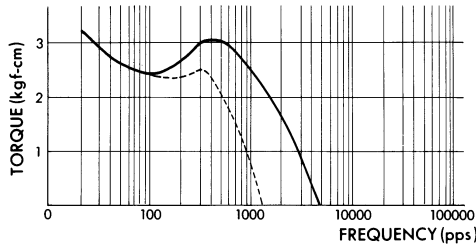

SST55D1030 DRIVER : TYPE A (C = 1 μF, R = 0) VOLTAGE : V_w = 12 V
EXCITING MODE = 2 Phase INERTIAL LOAD : 100 g-cm²

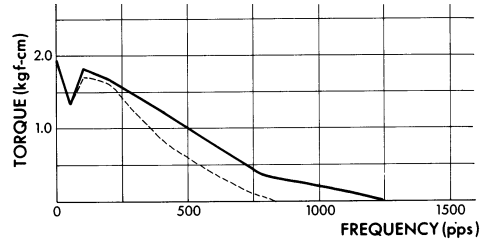

SST55D1040 DRIVER : TYPE A (C = 1 μF, R = 0) VOLTAGE : V_w = 24 V
EXCITING MODE = 2 Phase INERTIAL LOAD : 100 g-cm²

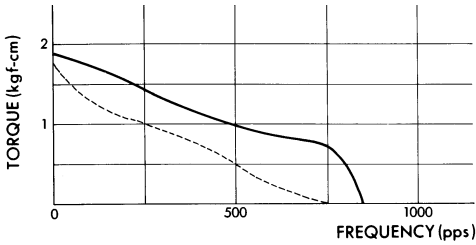

SST55D2010 DRIVER : SDU2401 CURRENT = 3.2 A/Phase
EXCITING MODE = 2 Phase INERTIAL LOAD : 100 g-cm²

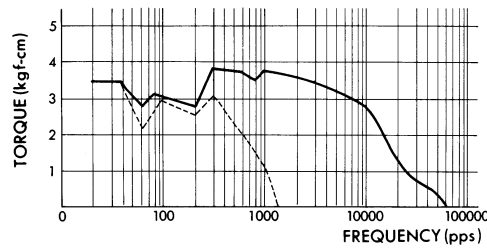

SST55D2020 DRIVER : SDU2201 CURRENT = 1.0 A/Phase
EXCITING MODE = 2 Phase INERTIAL LOAD : 100 g-cm²

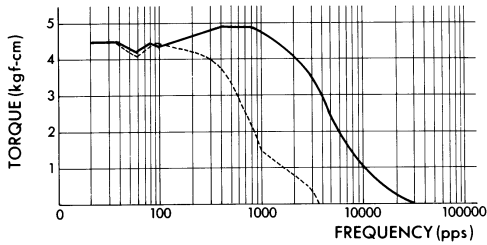

SST55D2020 DRIVER : TYPE B SUPPLY : V_s = 24 V
CURRENT = 1 A/Phase EXCITING MODE = 2 Phase
INERTIAL LOAD : 100 g-cm²

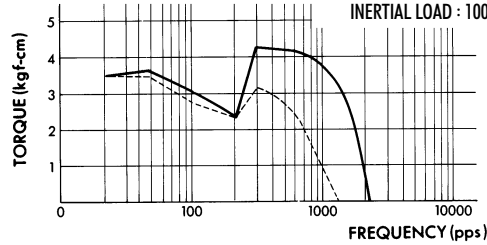

SST55D2030 DRIVER : SDU2201 CURRENT = 0.56 A/Phase
EXCITING MODE = 2 Phase INERTIAL LOAD : 100 g-cm²

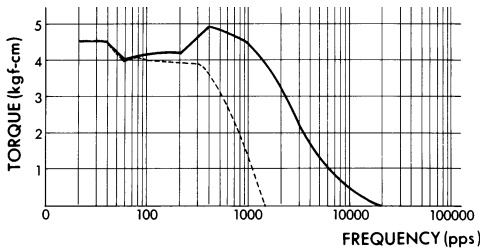

SST55D2040 DRIVER : TYPE A (C = 1 μF, R = 0) VOLTAGE : V_w = 24 V
EXCITING MODE = 2 Phase INERTIAL LOAD : 100 g-cm²

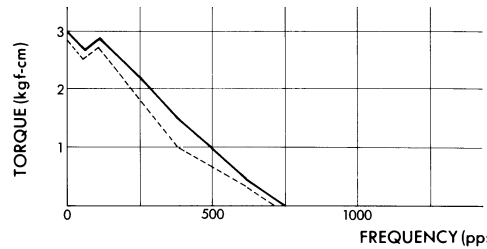

SST55D3010 DRIVER : SDU2401 CURRENT = 2.2 A/Phase
EXCITING MODE = 2 Phase INERTIAL LOAD : 100 g-cm²

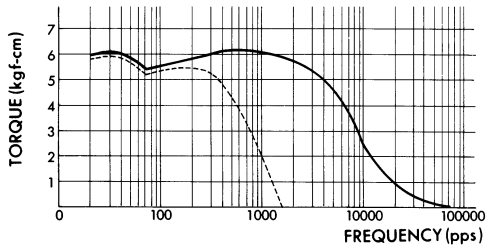

SST55D3020 DRIVER : SDU2201 CURRENT = 1.2 A/Phase
EXCITING MODE = 2 Phase INERTIAL LOAD : 100 g-cm²

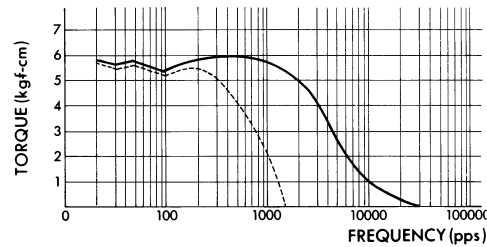

Discontinued
Not for New Design

SERIES
SST55D

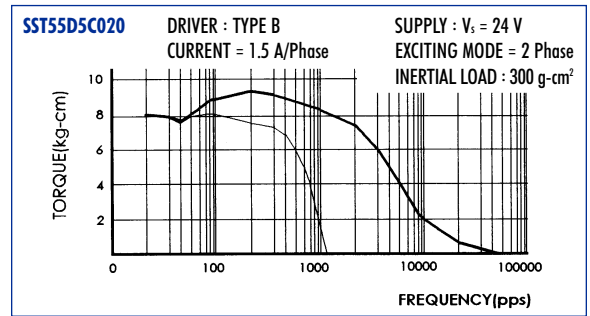
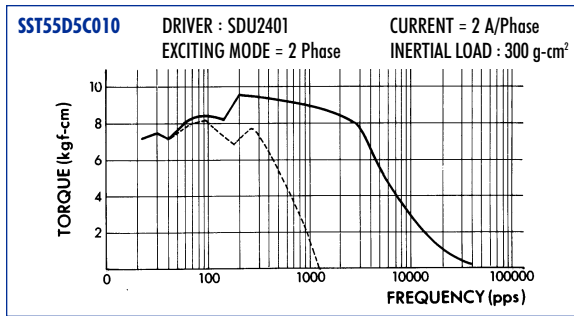
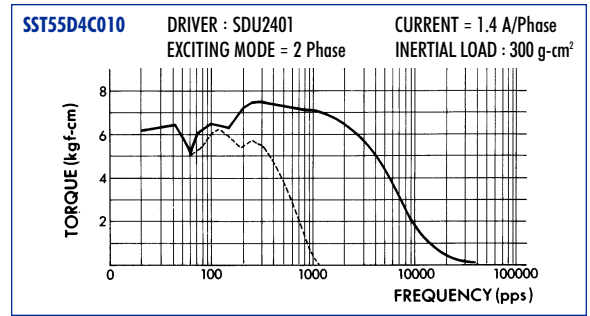
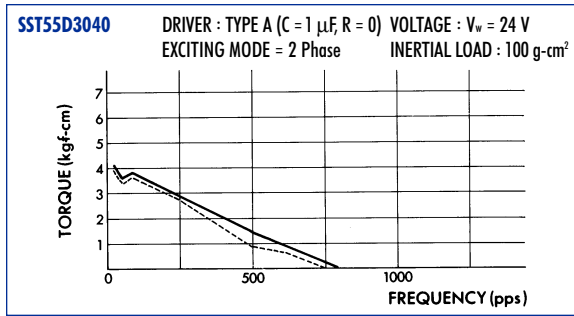
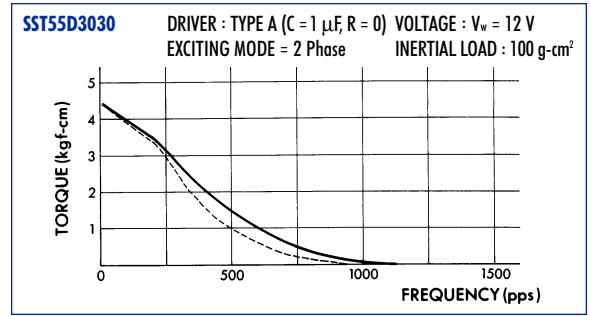
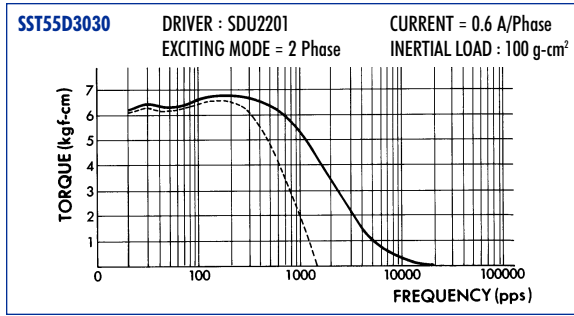

In this SST55D Series, we provide "with case" & "without case" types.

"with case" : Stator stack is covered with metal sleeve.

"without case" : Stator stack is exposed.

Note : SST55D4 and SST55D5 Series are only "with case".

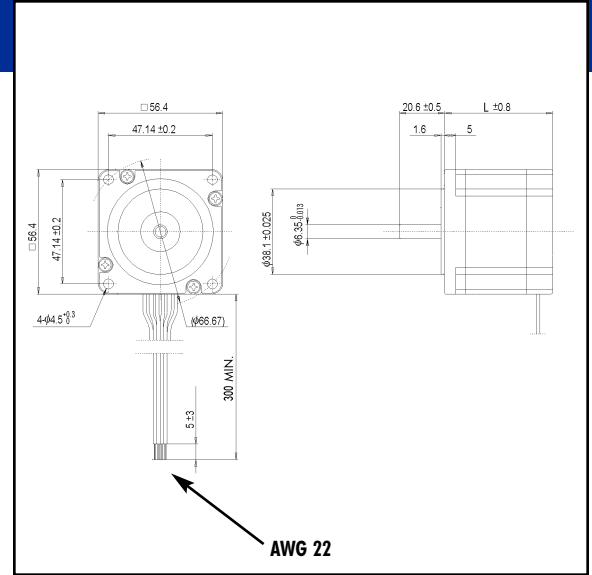
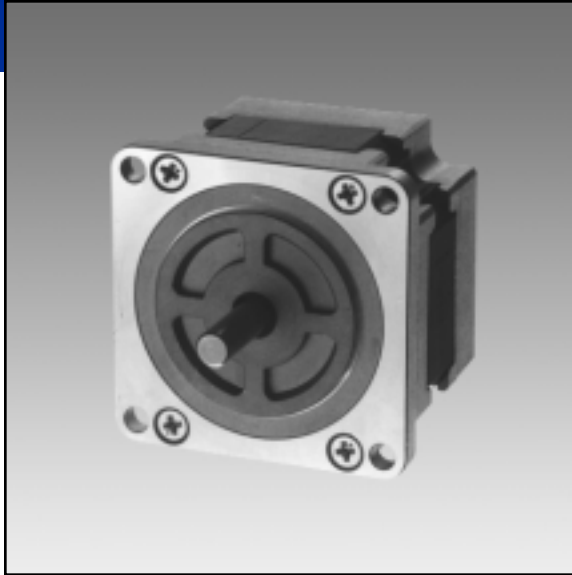

SPECIFICATION

MODEL		STEP ANGLE	VOLTAGE	CURRENT	RESISTANCE	INDUCTANCE	HOLDING TORQUE	ROTOR INERTIA	NUMBER OF LEADS	WEIGHT	DIMENSION
SINGLE SHAFT	DOUBLE SHAFT	DEG.	V	A/Phase	Ω/Phase	mH/Phase	kg-cm	g-cm ²	LEAD	kg	L
SST57D1100	SST57D1101	1.8	3.9	1.0	3.9	6.5	4.2	110	6	0.4	39
SST57D1200	SST57D1201	1.8	2.0	2.0	1.0	1.5	4.2	110	6	0.4	39
SST57D1300	SST57D1301	1.8	1.6	3.0	0.53	0.74	4.2	110	6	0.4	39
SST57D2100	SST57D2101	1.8	5.4	1.0	5.4	10.7	7.6	200	6	0.5	49
SST57D2200	SST57D2201	1.8	3.0	2.0	1.5	3.0	7.6	200	6	0.5	49
SST57D2300	SST57D2301	1.8	2.1	3.0	0.7	1.3	7.6	200	6	0.5	49
SST57D3100	SST57D3101	1.8	6.7	1.0	6.7	13	9.7	250	6	0.6	54
SST57D3200	SST57D3201	1.8	3.2	2.0	1.6	3.6	9.7	250	6	0.6	54
SST57D3300	SST57D3301	1.8	2.5	3.0	0.83	1.8	9.7	250	6	0.6	54
SST57D4100	SST57D4101	1.8	7.6	1.0	7.6	16	11.7	330	6	0.75	64
SST57D4200	SST57D4201	1.8	4.0	2.0	2.0	4.5	11.7	330	6	0.75	64
SST57D4300	SST57D4301	1.8	2.85	3.0	0.95	2.1	11.7	330	6	0.75	64
SST57D5100	SST57D5101	1.8	9.2	1.0	9.2	20	14.3	430	6	0.95	75
SST57D5200	SST57D5201	1.8	4.8	2.0	2.4	5.7	14.3	430	6	0.95	75
SST57D5300	SST57D5301	1.8	3.42	3.0	1.14	2.6	14.3	430	6	0.95	75

TYPICAL PERFORMANCE

REFER TO PAGE 30 FOR DRIVER

— PULL OUT
- - - - PULL IN

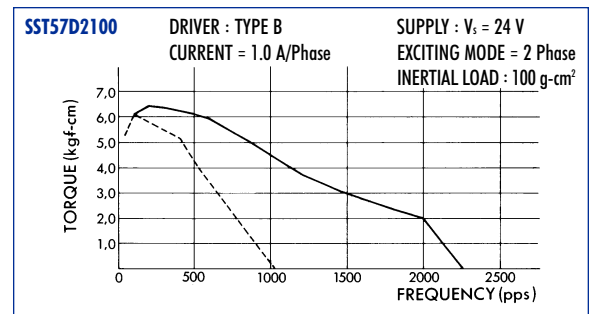
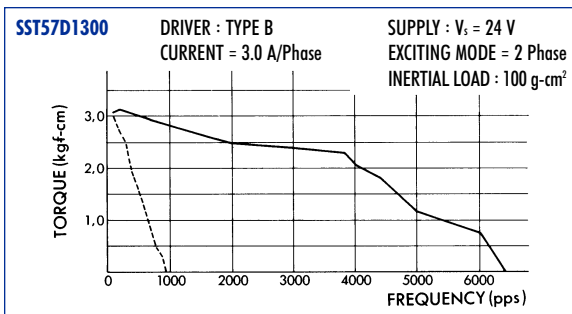
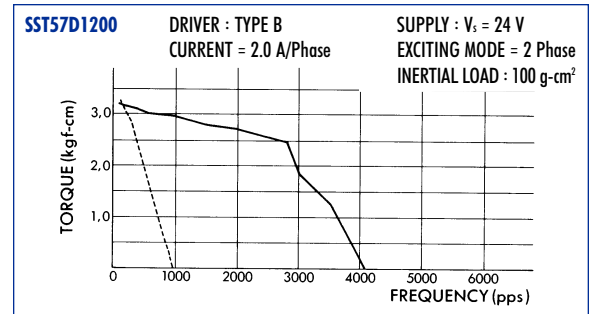
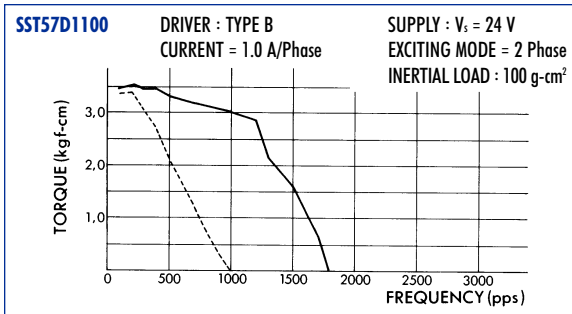

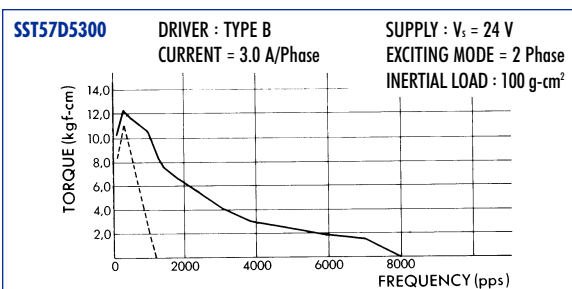
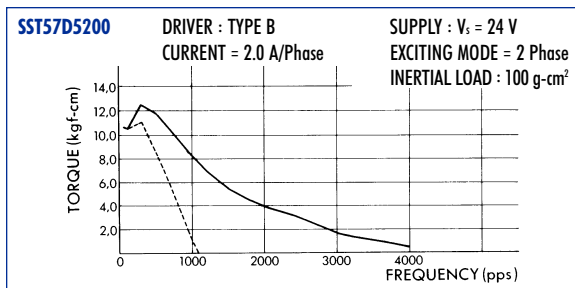
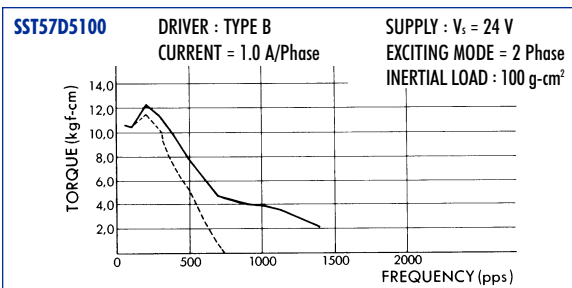
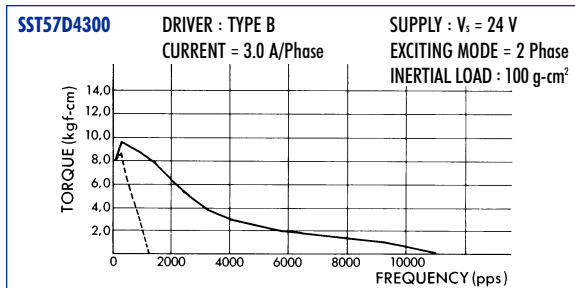
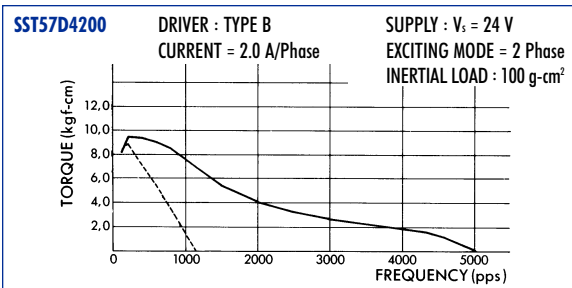
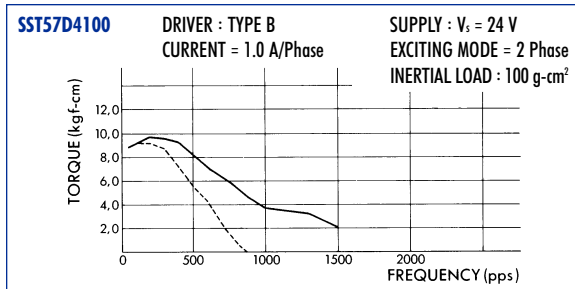
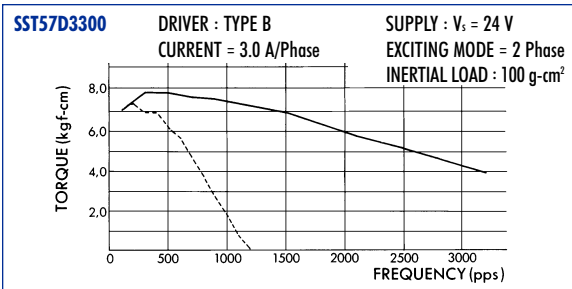
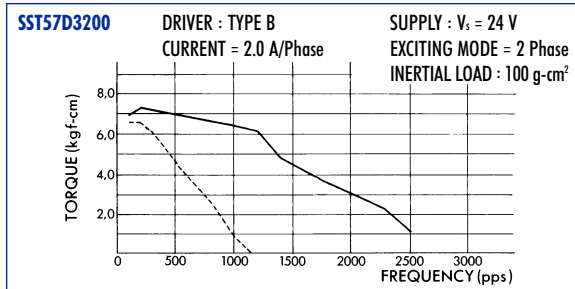
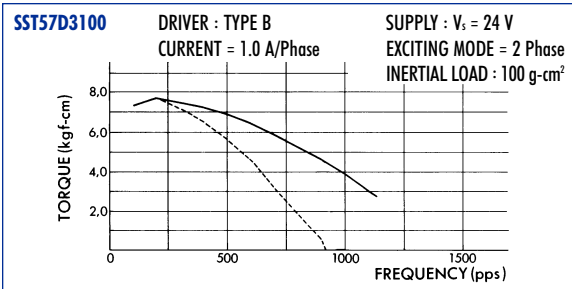
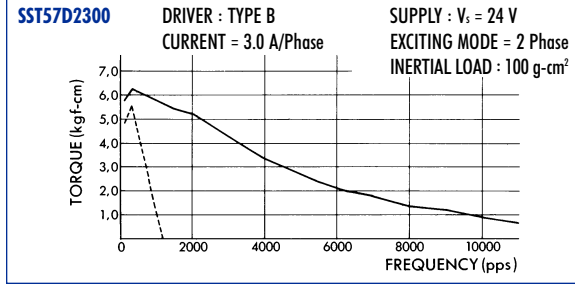
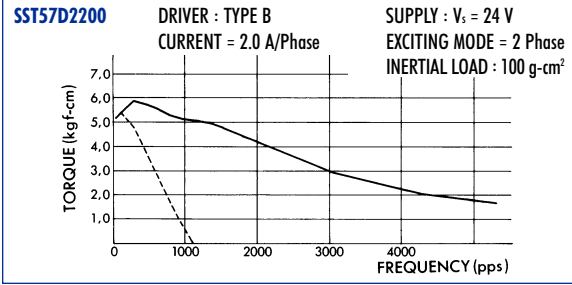

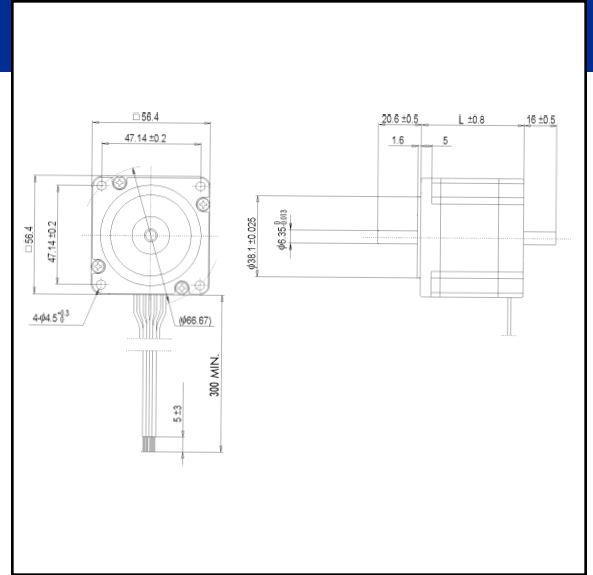
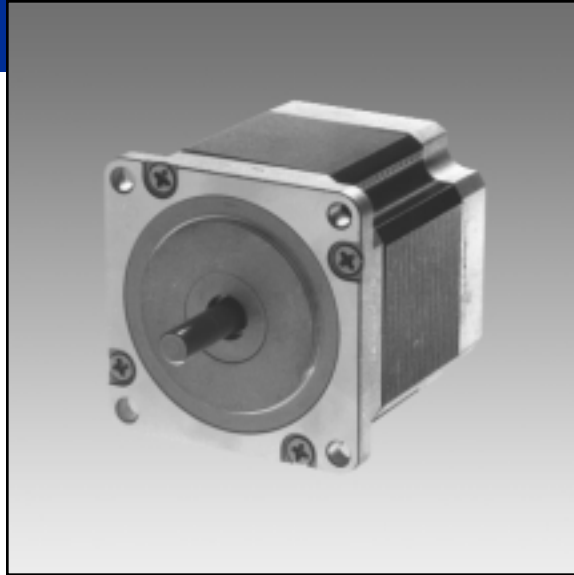

SPECIFICATION

MODEL		STEP ANGLE	VOLTAGE	CURRENT	RESISTANCE	INDUCTANCE	HOLDING TORQUE	ROTOR INERTIA	NUMBER OF LEADS	WEIGHT	DIMENSION
SINGLE SHAFT	DOUBLE SHAFT	DEG.	V	A/PHASE	Ω/PHASE	MH/PHASE	KG-CM	G-CM2	LEAD	KG	L
SST58D1810	SST58D1811	1.8	5.0	1.0	5.0	5.4	4.5	135	8	0.49	42
SST58D1820	SST58D1821	1.8	2.4	2.0	1.2	1.3	4.5	135	8	0.49	42
SST58D1830	SST58D1831	1.8	1.5	3.0	0.5	0.54	4.5	135	8	0.49	42
SST58D2810	SST58D2811	1.8	6.2	1.0	6.2	9.7	7.6	230	8	0.6	49
SST58D2820	SST58D2821	1.8	3.0	2.0	1.5	2.6	7.6	230	8	0.6	49
SST58D2830	SST58D2831	1.8	2.2	3.0	0.73	1.1	7.6	230	8	0.6	49
SST58D3810	SST58D3811	1.8	6.9	1.0	6.9	14.0	9.0	290	8	0.71	54
SST58D3820	SST58D3821	1.8	3.4	2.0	1.7	3.6	9.0	290	8	0.71	54
SST58D3830	SST58D3831	1.8	2.1	3.0	0.7	1.3	9.0	290	8	0.71	54
SST58D4810	SST58D4811	1.8	7.2	1.0	7.2	12.0	11.0	330	8	0.86	65
SST58D4820	SST58D4821	1.8	3.6	2.0	1.8	3.0	11.0	330	8	0.86	65
SST58D4830	SST58D4831	1.8	2.4	3.0	0.8	1.3	11.0	330	8	0.86	65
SST58D5810	SST58D5811	1.8	8.8	1.0	8.8	19.0	14.2	430	8	1.1	77
SST58D5820	SST58D5821	1.8	4.8	2.0	2.4	5.1	14.2	430	8	1.1	77
SST58D5830	SST58D5831	1.8	3.0	3.0	1.0	2.62	14.2	430	8	1.1	77

TYPICAL PERFORMANCE

REFER TO PAGE 30 FOR DRIVER

— PULL OUT
- - - PULL IN

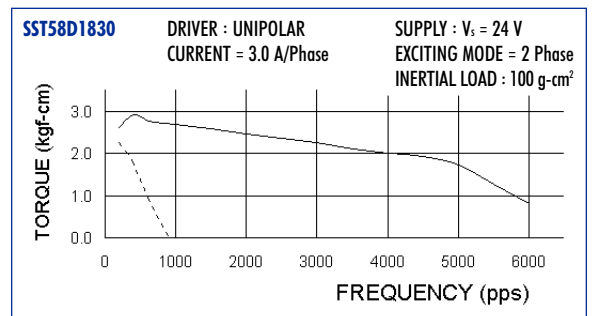
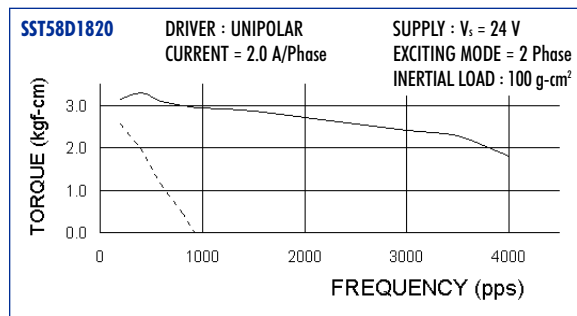
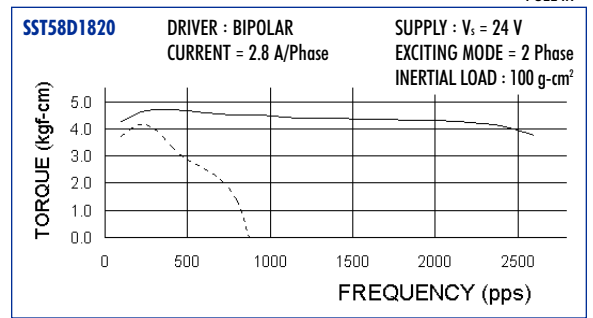
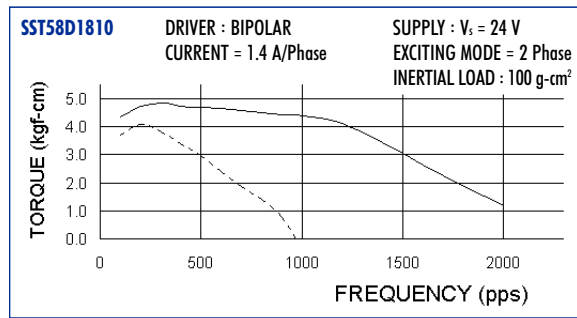

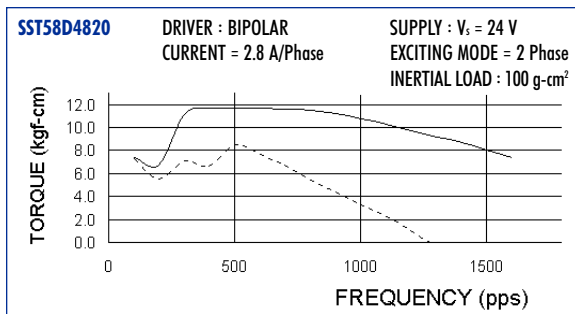
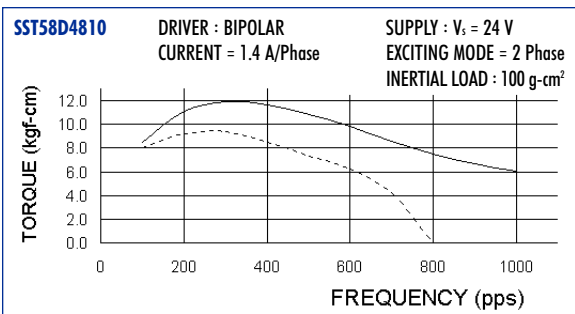
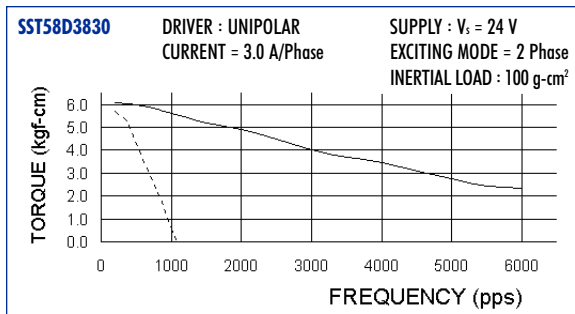
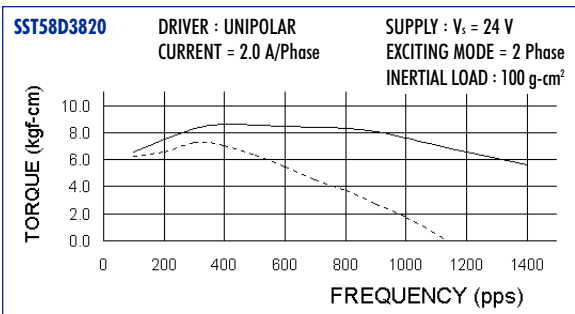
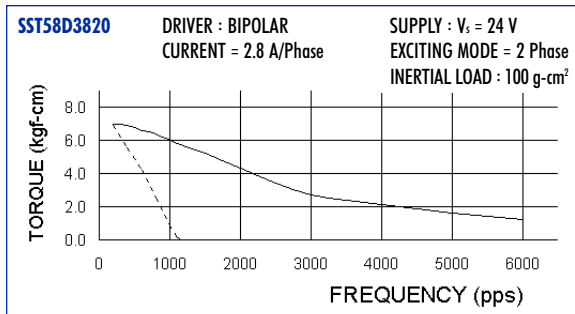
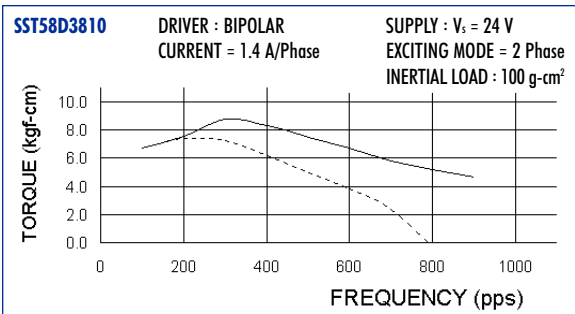
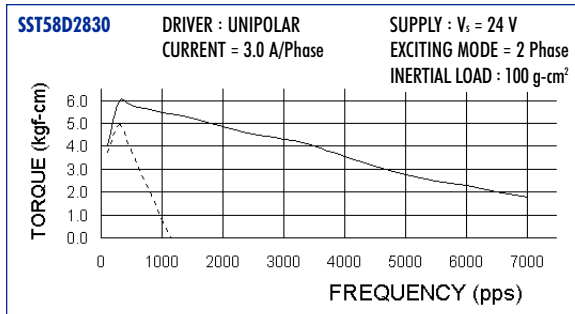
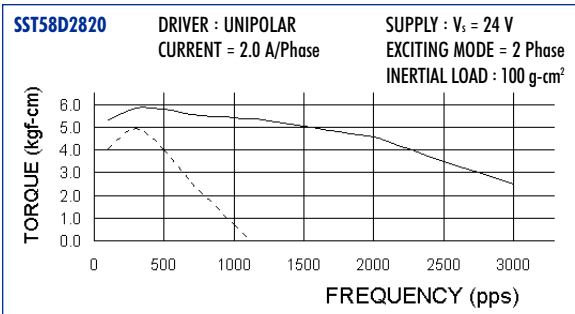
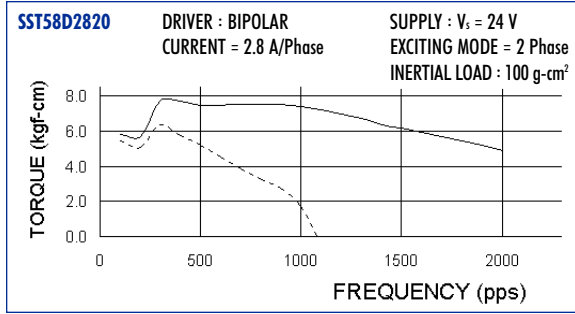
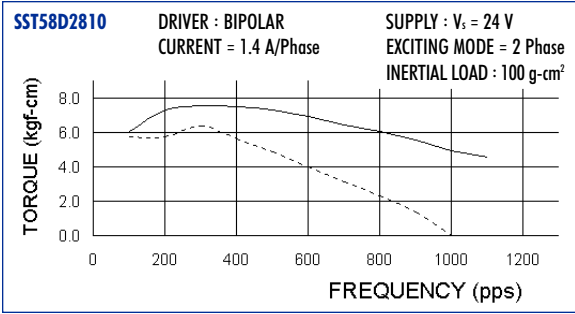

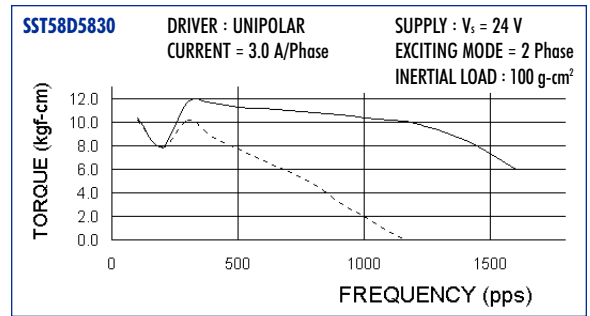
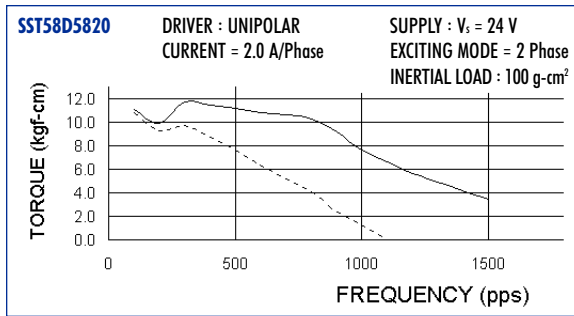
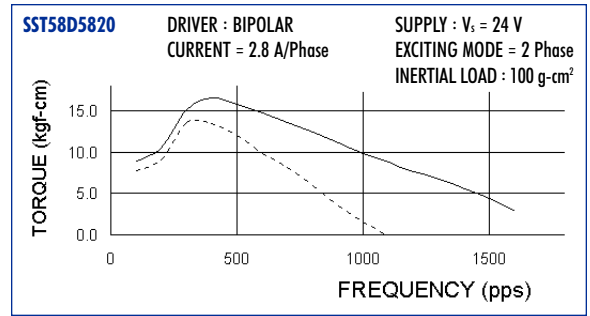
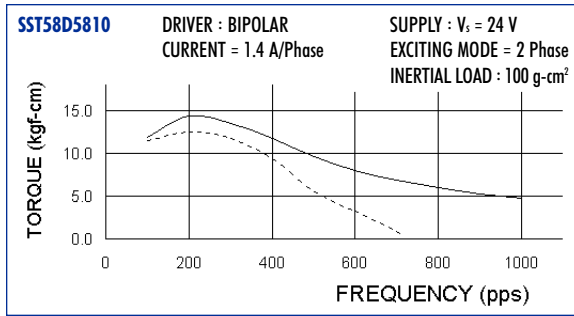
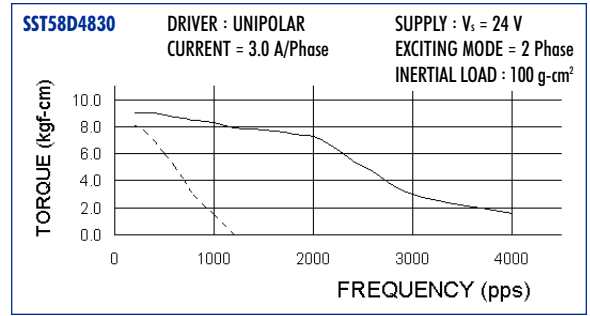
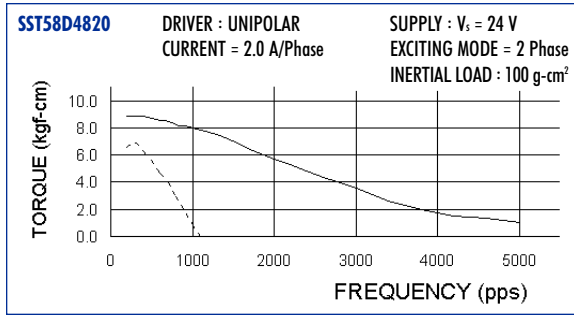

RATING CONVERSIONS

STANDARD DRIVE SCHEME	RATING	UNIPOLAR MULTIPLIER	BIPOLAR SERIES MULTIPLIER	BIPOLAR PARALLEL MULTIPLIER
Unipolar or Bipolar (center-tap to end)	VOLTS (DC)	1	1.4	0.7
Unipolar or Bipolar (center-tap to end)	CURRENT (A)	1	0.7	1.4
Unipolar or Bipolar (center-tap to end)	RESISTANCE (Ω)	1	2	0.5
Unipolar or Bipolar (center-tap to end)	INDUCTANCE (mH)	1	4	1
Unipolar or Bipolar (center-tap to end)	HOLDING TORQUE	1	1.4	1.4

Step Motors are versatile and have many drive methods. To determine the motor rating when using a drive method that differs from the standard rating approach, multiply the standard rated value by the number indicated in the chart that corresponds to the drive scheme desired.

DIRECTION OF ROTATION

Phase sequence to produce clockwise rotation viewed from mounting end.

STEP	A	B	\bar{A}	\bar{B}
1	+	+	-	-
2	-	+	+	-
3	-	-	+	+
4	+	-	-	+
5	+	+	-	-

Phase Sequence (parallel connected)

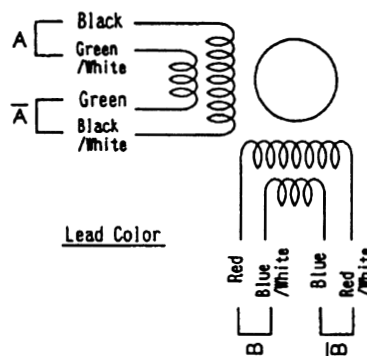

Phase Sequence (series connected)

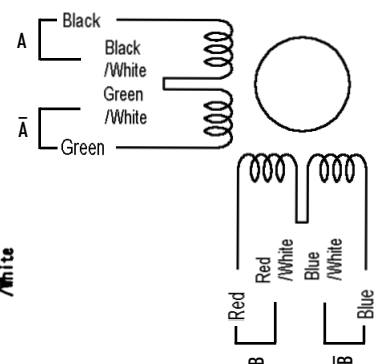

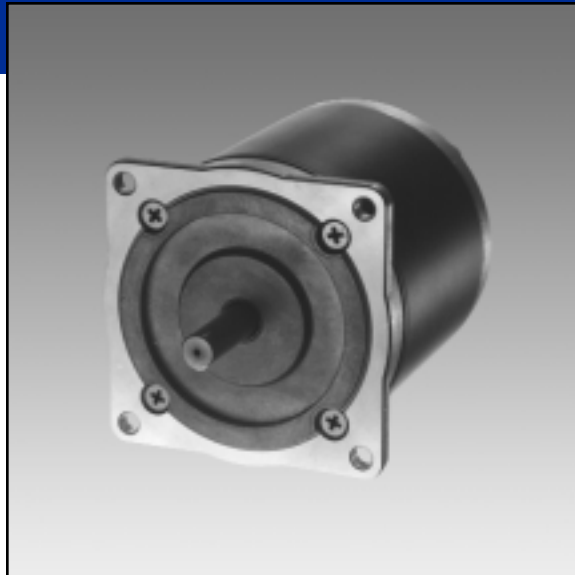
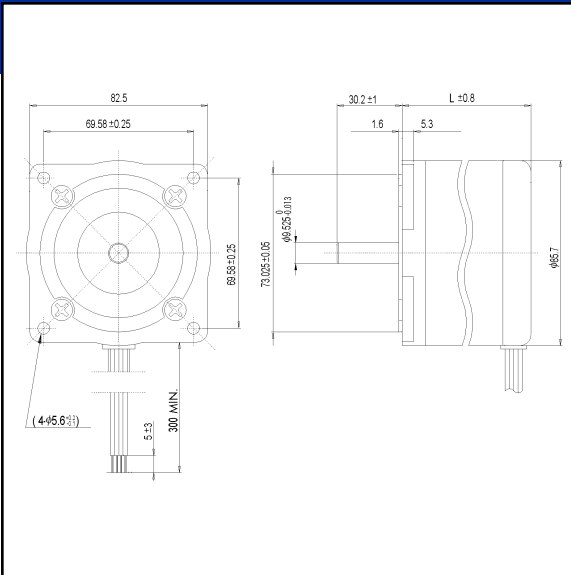

SPECIFICATION

MODEL		STEP ANGLE	VOLTAGE	CURRENT	RESISTANCE	INDUCTANCE	HOLDING TORQUE	ROTOR INERTIA	NUMBER OF LEADS	WEIGHT	DIMENSION
SINGLE SHAFT	DOUBLE SHAFT	DEG.	V	A/Phase	Ω/Phase	mH/Phase	kg-cm	g-cm ²	LEAD	kg	L
SST83D1C010	SST83D1C011	1.8	1.8	4.5	0.4	0.96	16	570	6	1.4	62
SST83D1C020	SST83D1C021	1.8	2.8	2.8	1	2.6	16	570	6	1.4	62
SST83D1C030	SST83D1C031	1.8	5.5	1.25	4.4	15	17	570	6	1.4	62
SST83D2C010	SST83D2C011	1.8	3	4	0.75	2.4	31	1100	6	2.5	93.5
SST83D2C020	SST83D2C021	1.8	6	2	3	13	36	1100	6	2.5	93.5
SST83D2C030	SST83D2C031	1.8	4.2	3.5	1.2	4.7	42	1800	6	3.5	128.5

TYPICAL PERFORMANCE

REFER TO PAGE 30 FOR DRIVER

— PULL OUT
- - - PULL IN

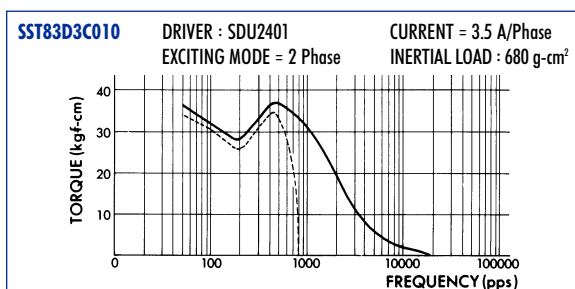
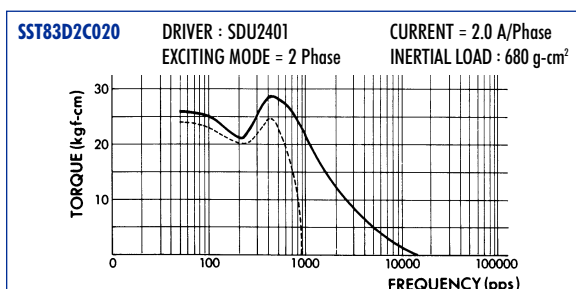
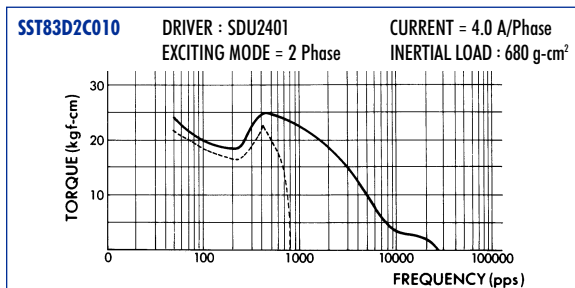
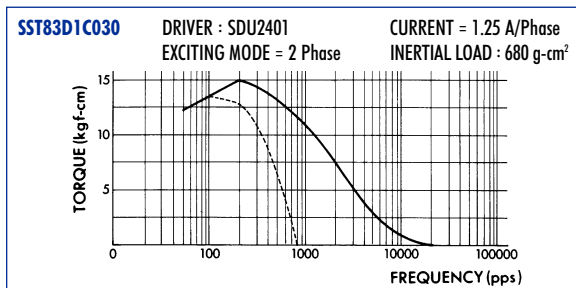
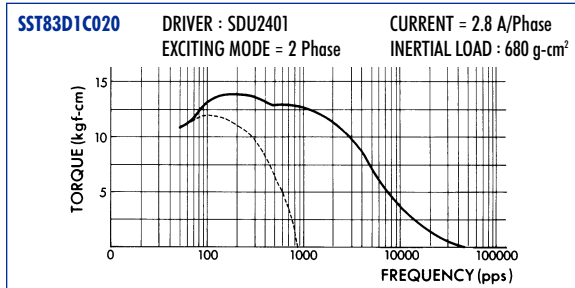
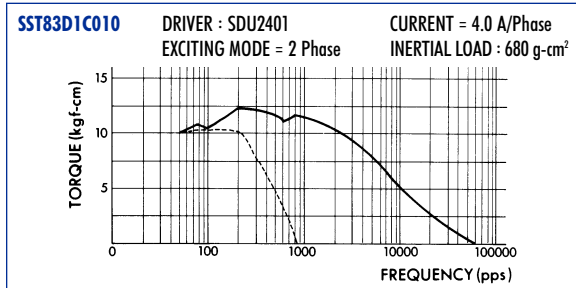

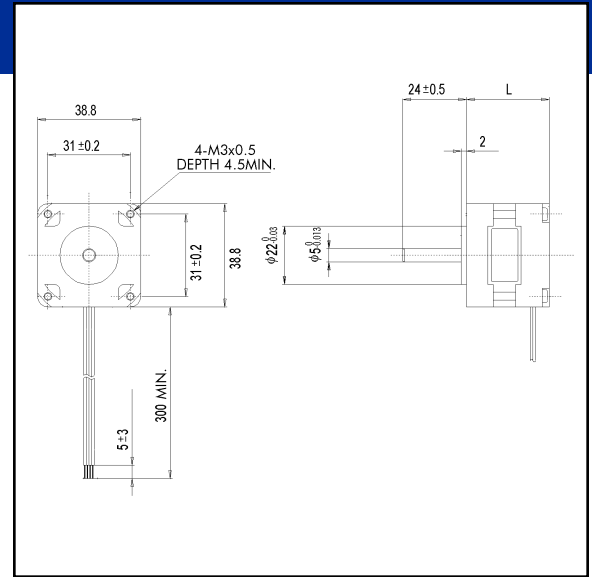
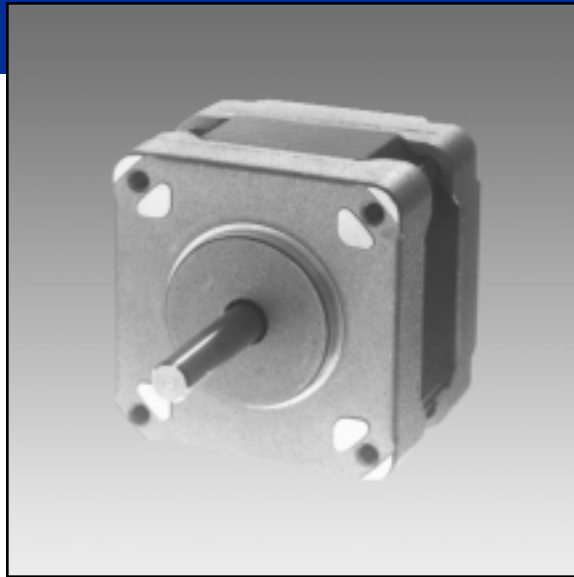

SPECIFICATION

MODEL		STEP ANGLE	VOLTAGE	CURRENT	RESISTANCE	INDUCTANCE	HOLDING TORQUE	ROTOR INERTIA	NUMBER OF LEADS	WEIGHT	DIMENSION
SINGLE SHAFT	DOUBLE SHAFT	DEG.	V	A/Phase	Ω/Phase	mH/Phase	kg-cm	g-cm ²	LEAD	kg	L
SST39A1010	SST39A1011	0.36	2.0	0.75	2.6	2.8	0.8	17	10	0.17	31
SST39A1020	SST39A1021	0.36	6.9	0.21	33	2.6	0.8	17	10	0.17	31
SST39A2010	SST39A2011	0.36	2.1	0.75	2.8	3.8	1.2	27	10	0.20	37
SST39A2020	SST39A2021	0.36	2.7	0.54	5.0	7.0	1.2	27	10	0.20	37

TYPICAL PERFORMANCE

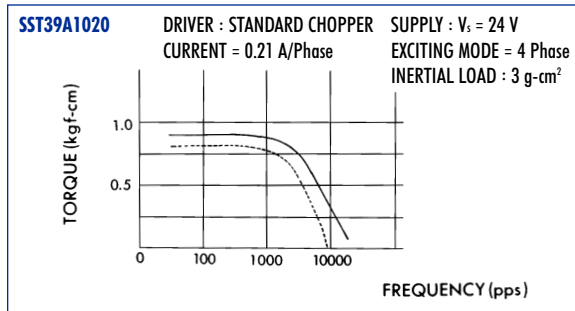

REFER TO PAGE 30 FOR DRIVER

— PULL OUT
- - - PULL IN

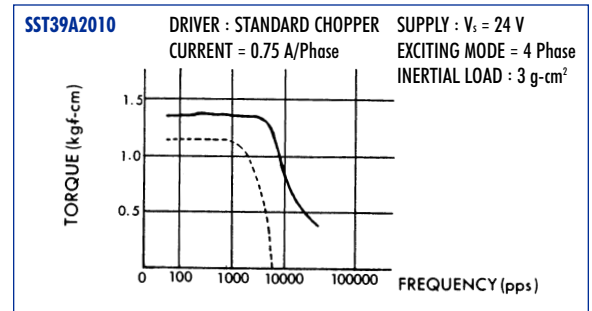

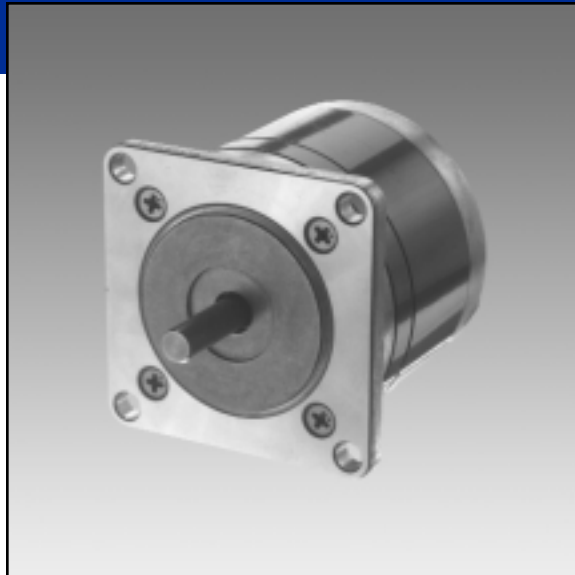
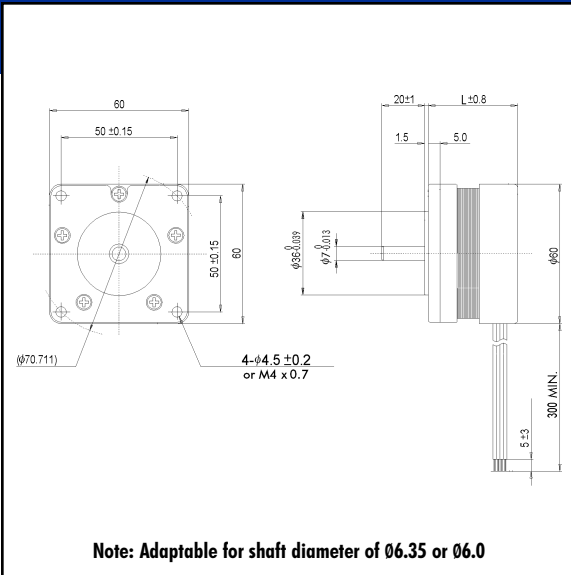

SPECIFICATION

MODEL		STEP ANGLE	VOLTAGE	CURRENT	RESISTANCE	INDUCTANCE	HOLDING TORQUE	ROTOR INERTIA	NUMBER OF LEADS	WEIGHT	DIMENSION
SINGLE SHAFT	DOUBLE SHAFT	DEG.	V	A/Phase	Ω/Phase	mH/Phase	kg-cm	g-cm ²	LEAD	kg	L
SST60B1010	SST60B1011	0.72	1.9	1	1.9	2.2	2.5	70	10	0.35	38.5
SST60B1020	SST60B1021	0.72	1.9	0.75	2.5	3.5	2.5	70	10	0.35	38.5
SST60B3010	SST60B3011	0.72	1.8	1.3	1.4	3	4	160	10	0.56	53.5
SST60B3020	SST60B3021	0.72	3.1	0.77	4	8	4	160	10	0.56	53.5

TYPICAL PERFORMANCE

REFER TO PAGE 30 FOR DRIVER

— PULL OUT
- - - - PULL IN

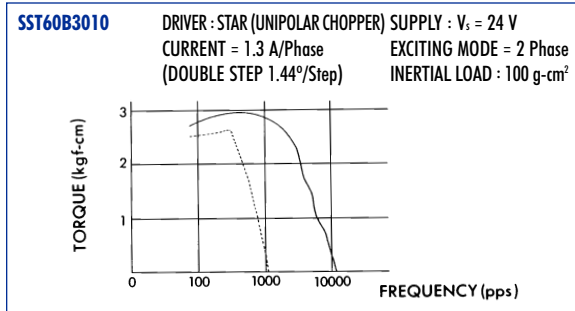
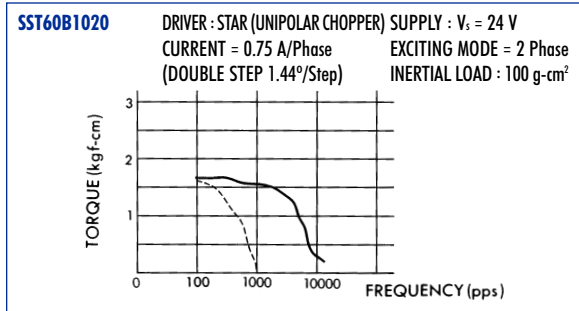

STEP MOTOR WIRING DIAGRAM

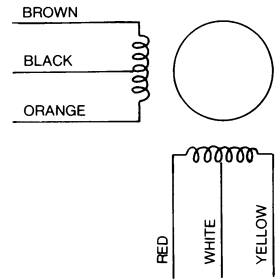
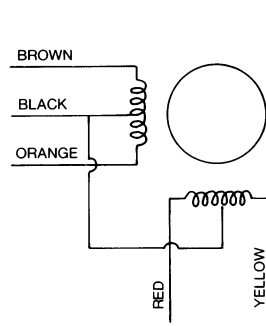
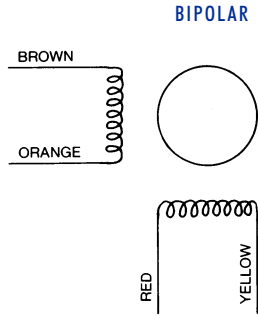

A = BROWN, \bar{A} = ORANGE, B = RED, \bar{B} = YELLOW
 BLACK = A COMMON in unipolar 6-lead configuration, and A/B COMMON for unipolar 5-lead wire configuration
 WHITE = B COMMON

EXCITATION TABLE - BIPOLAR

STEP SEQUENCE		PHASE A	PHASE B	PHASE \bar{A}	PHASE \bar{B}
CW*	CCW*				
1	5	+	+	-	-
2	4	-	+	+	-
3	3	-	-	+	+
4	2	+	-	-	+
5	1	+	+	-	-

*Viewed from shaft side

EXCITATION TABLE - UNIPOLAR

STEP SEQUENCE		PHASE A	PHASE B	PHASE \bar{A}	PHASE \bar{B}	COMMON
CW*	CCW*					
1	5	-	-	-	-	+
2	4	-	-	-	-	+
3	3	-	-	-	-	+
4	2	-	-	-	-	+
5	1	-	-	-	-	+

*Viewed from shaft side

STEP MOTOR DRIVE CIRCUIT

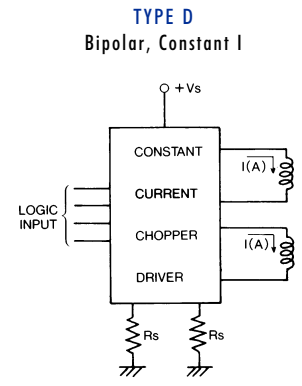
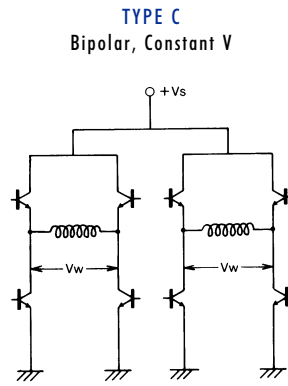
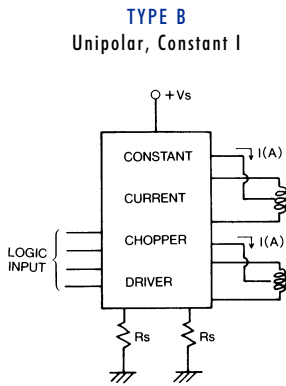
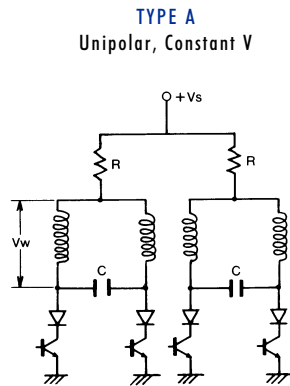

STEP MOTOR DRIVERS

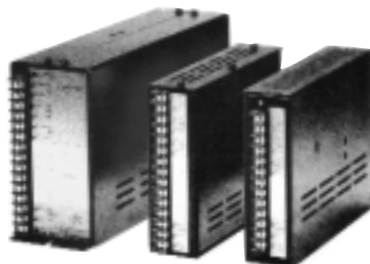

SDU2401 SDU2201 SDU2101

MODEL	TYPE	MAX. CURRENT/PHASE
SDU 2201	Unipolar, Constant Current	1.5 Amps
SDU 2401	Unipolar, Constant Current	4.0 Amps
SDU 2101	Bipolar, Constant Current	2.0 Amps

NOTE: All drivers are 4 phase and are capable of half step (1-2 phase) and full step (2 phase) modes.

Input for all models is 110 VAC, 60 Hz

SPECIFICATION

ELECTRICAL CHARACTERISTICS

RATED VOLTAGE	VDC	12
RATED LOAD	N-cm	0.098
	gf-cm	10
RATED SPEED	rpm	4,600 ± 450
RATED CURRENT	mA (max.)	195
STARTING CURRENT	A (max.)	1.5 (peak)
NO LOAD SPEED	rpm	5,000 (reference)
NO LOAD CURRENT	mA (max.)	135
TORQUE CONSTANT	N-cm/A	1.96 (nominal)
	gf-cm/A	200 (nominal)
LIFE	hours (typical)	10,000 (at rated voltage, 1,400 rpm, continuous operating)
ROTOR INERTIA	g-cm ²	6
ACOUSTIC NOISE	dB(A)	55 (at rated voltage, no load, distance of 10 cm from motor)
VIBRATION	m/s ²	9.8 (at rated voltage, no load)
	G	1 (at rated voltage, no load)
FG OUTPUT	pulse/rev.	6
HIGH LEVEL	V (min.)	2.0 (low level)
	V (max.)	0.8

CONNECTOR

HOUSING P/N	-	JST p/n 06ZR-8M (green)
LEAD WIRE	-	UL-1571, AWG #28

ROTATION

DIRECTION	CW	4pin : Vcont > Vref (facing at shaft)
	CCW	4pin : Vcont < Vref (facing at shaft)

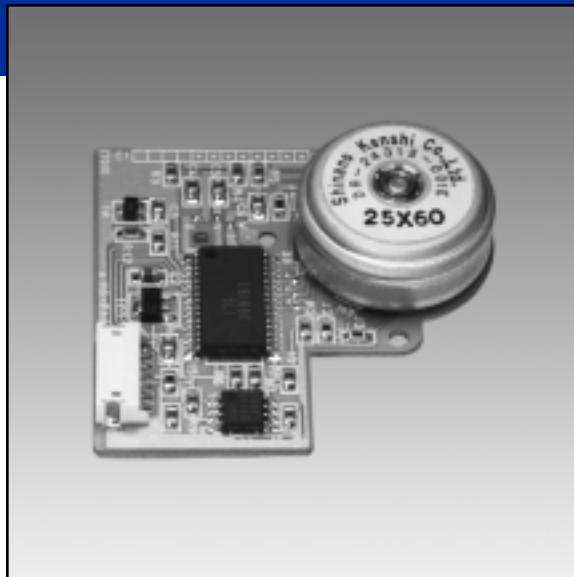

CONNECTOR PIN ASSIGNMENT

NO.	FUNCTION	COLOR
1	VDC: 12 V	White
2	FG	Gray
3	GND	Gray
4	Vcont	Gray
5	Vref	Gray
6	On/Off (Low Start)	Gray

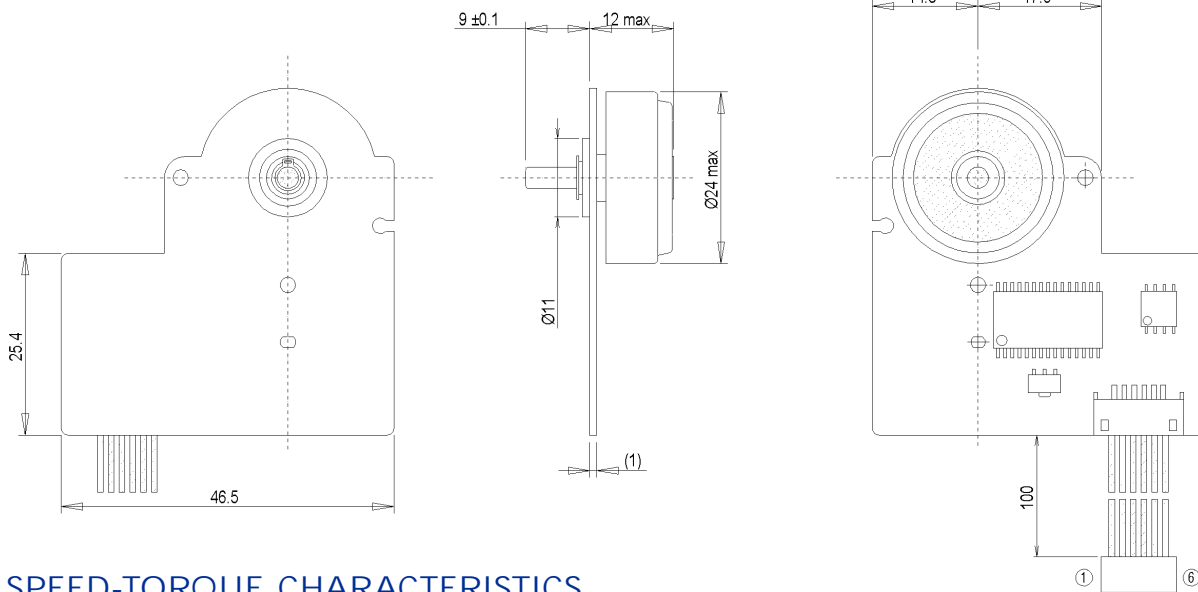

SPEED-TORQUE CHARACTERISTICS

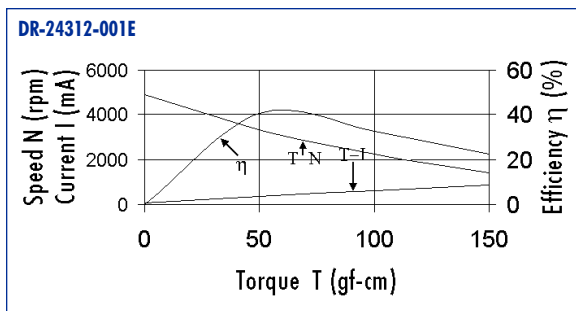

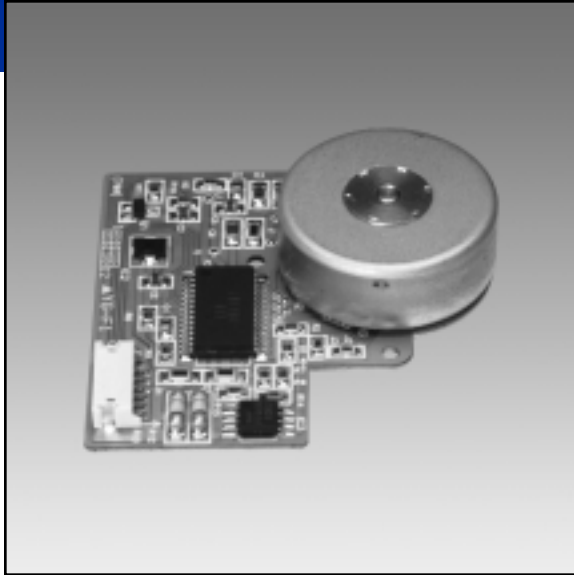

CONNECTOR PIN ASSIGNMENT

NO.	FUNCTION	COLOR
1	VDC: 12 V	White
2	Encoder Out	Gray
3	GND	Gray
4	Vref: 2.5 V	Gray
5	Vcont: 0 to 5 V	Gray
6	On/Off (Low Start)	Gray

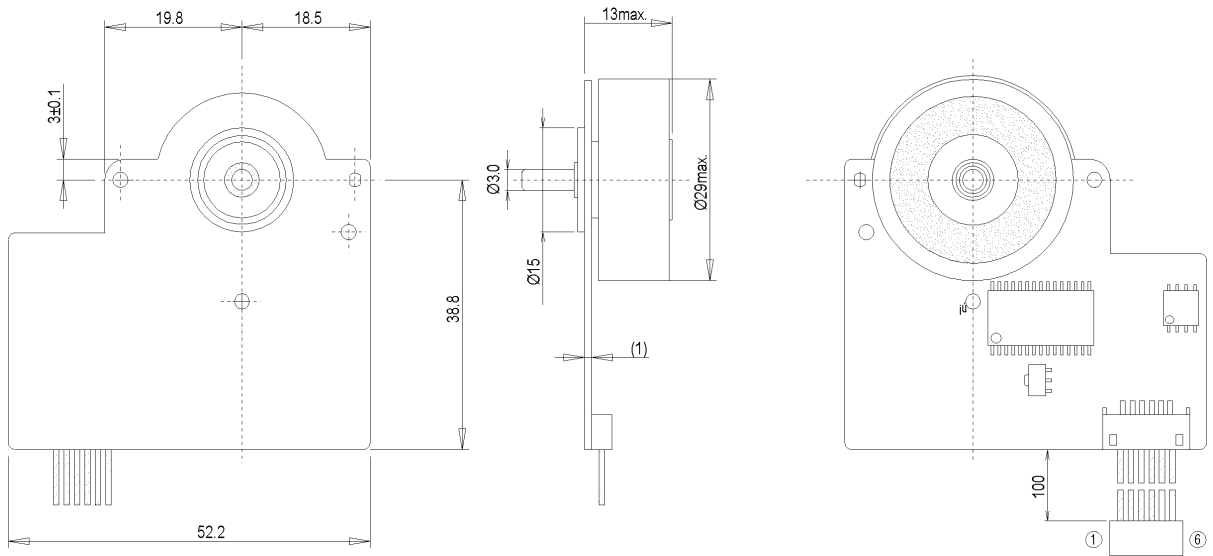

SPECIFICATION

ELECTRICAL CHARACTERISTICS		
RATED VOLTAGE	VDC	12
RATED LOAD	N-cm gf-cm	0.49 5
RATED SPEED	rpm	3,000 ± 10%
RATED CURRENT	mA (max.)	350
STARTING CURRENT	A (max.)	1.5 (peak)
NO LOAD SPEED	rpm	3,500 (reference)
NO LOAD CURRENT	mA (max.)	200
TORQUE CONSTANT	N-cm/A gf-cm/A	3.06 (nominal) 312 (nominal)
LIFE	hours (typical)	10,000 (at rated load, 3,000 rpm)
ROTOR INERTIA	g-cm ²	26.7
ACOUSTIC NOISE	dB(A)	50 (at distance of 10 cm)
ENCODER		
TYPE	-	magnetic pulse
RESOLUTION	pulse/rev.	3
OUTPUT LEVEL	V (high) V (low)	11 ± 1 0 to 0.5
DUTY CYCLE	%	66.7 ± 20
CONNECTOR		
HEADER P/N	-	JST p/n S6B-ZR-SM3 (white)
HARNESS P/N	-	JST p/n 06ZR-8M (green)
LEAD WIRE	-	UL-1571, AWG #28
ROTATION		
DIRECTION	CW CCW	4pin : Vcont > Vref (facing at shaft) 4pin : Vcont < Vref (facing at shaft)

SPEED-TORQUE CHARACTERISTICS

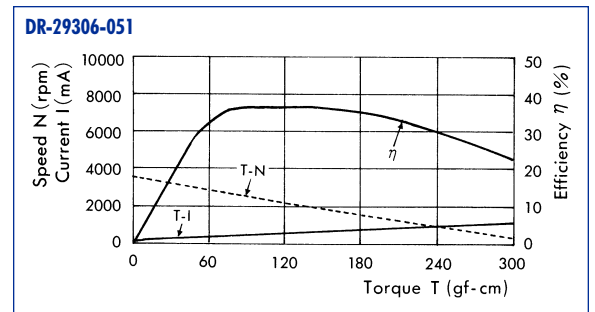



SPECIFICATION

ELECTRICAL CHARACTERISTICS

RATED VOLTAGE	VDC	11.6 (at motor terminals)
RATED LOAD	N-cm gf-cm	9.8×10^3 100
RATED SPEED	rpm	3,600 (nominal)
RATED CURRENT	A (max.)	0.8
STARTING CURRENT	A (max.)	2.3 (peak, nominal)
LIFE	hours (typical)	10,000 (at rated voltage, rated load)
ROTOR INERTIA	kg-m ²	3.8×10^{-4} (nominal)
HALL SENSOR TYPE	-	open collector TTL comparable outputs
TEMPERATURE RISE	K (max.)	40 (at rated load with 396.6 gf side load, rated speed)

CONNECTOR

HOUSING	-	molex 5231 #10-01-4084
CONTACT	-	molex 5230 #08-70-0072, molex 5230 #08-70-0073
LEAD WIRE	-	UL-1061, AWG #28

CONNECTOR PIN ASSIGNMENT

NO.	FUNCTION	COLOR
1	Coil A	Purple
2	Coil B	Blue
3	Coil C	Green
4	Hall C	Yellow
5	Hall B	Orange
6	Hall A	Red
7	VDC: 5 V	Brown
8	GND	Black

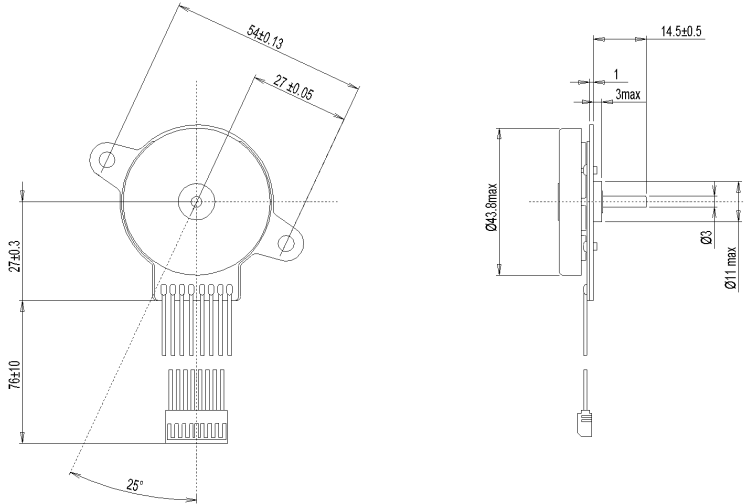

Timing Diagram

CCW ROTATION (VIEWED FROM OUTPUT SHAFT SIDE)

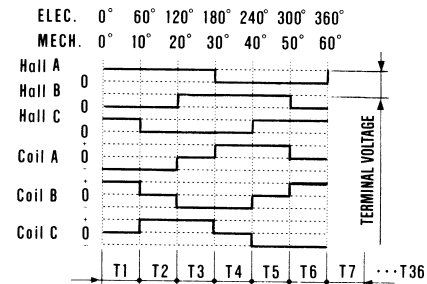

CW ROTATION

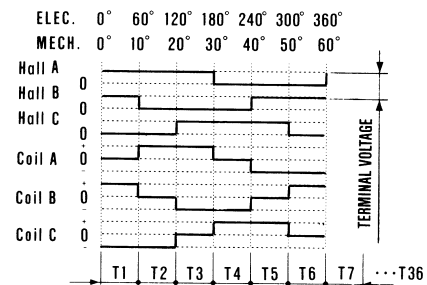

SPEED-TORQUE CHARACTERISTICS

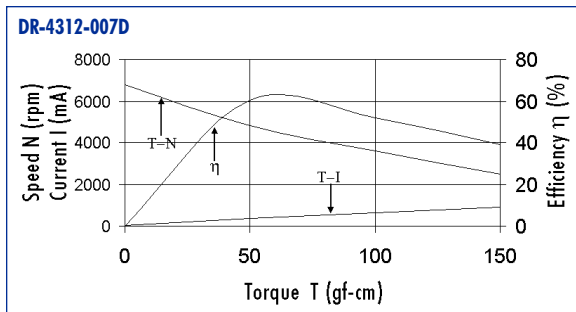

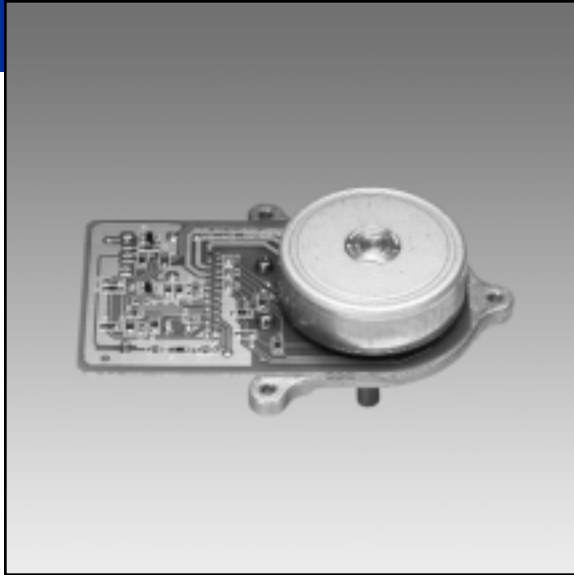

CONNECTOR PIN ASSIGNMENT

NO.	FUNCTION
1	VDC: 12 V
2	FG Output
3	On/Off (Low Start)
4	GND
5	N/C

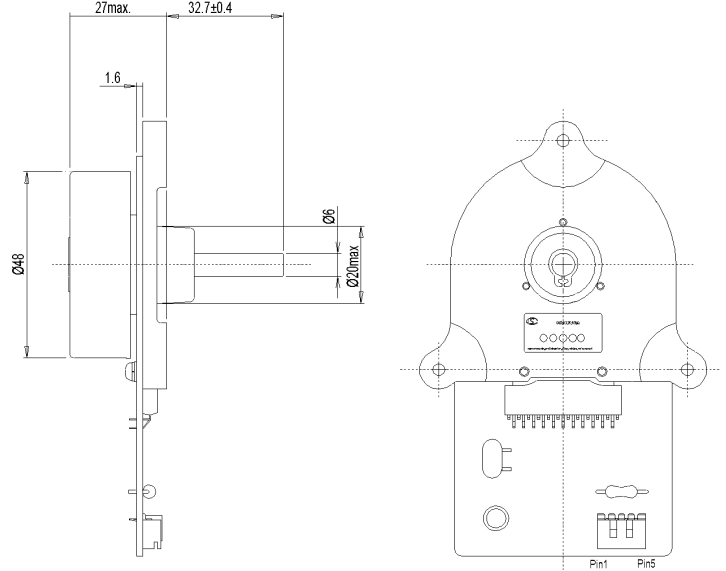
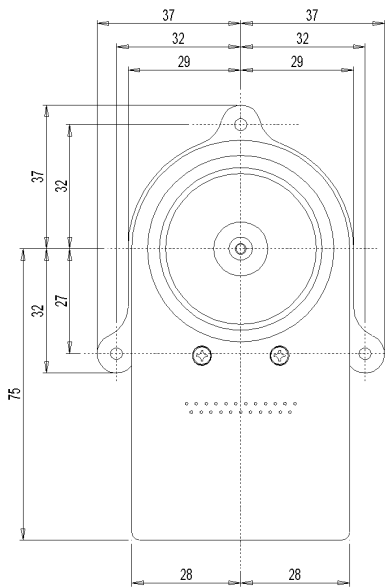

SPECIFICATION

ELECTRICAL CHARACTERISTICS

OPERATING VOLTAGE	VDC	11.0 to 12.6
RATED LOAD	N-cm gf-cm	0.19 20
RATED SPEED	rpm	6,000 ± 5% (controlled)
RATED CURRENT	mA (max.)	600
STARTING CURRENT	A (max.)	2.0 (peak)
NO LOAD SPEED	rpm	6,000 (reference)
LIFE	hours (typical)	10,000 (at rated load, 6,000 rpm)
ACOUSTIC NOISE	dB(A) (max.)	45 (at distance of 1 m)

CONNECTOR

HEADER	-	molex p/n 5484-05AX or equivalent
--------	---	-----------------------------------

ROTATION

DIRECTION	CW	(facing at shaft)
-----------	----	-------------------

SPEED-TORQUE CHARACTERISTICS

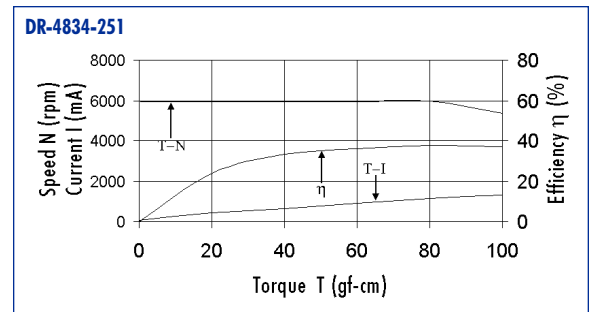

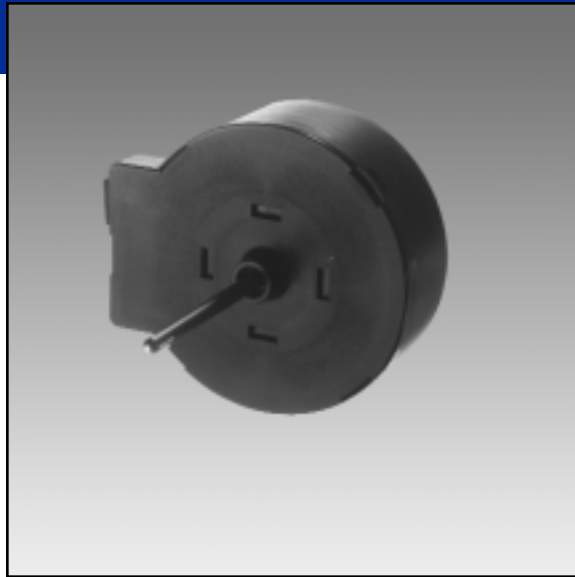

SPECIFICATION

ELECTRICAL CHARACTERISTICS

RATED POWER (OUTPUT)	W	1.2
OPERATING VOLTAGE	VDC	12 ± 10%
RATED TORQUE	gf-cm	50 (typical)
RATED SPEED	rpm	2,000 (typical)
RATED CURRENT	mA	220 (typical)
STARTING CURRENT	A (max.)	1.5
NO LOAD SPEED	rpm	2,715 (typical)
NO LOAD CURRENT	mA	9 (typical)
TORQUE CONSTANT	g-cm/A	425 (typical)
LIFE	hours (min.)	35,000 (at rated load, voltage, continuous operation)
TEMPERATURE RATING	C	-30 to 40 (ambient)
ACOUSTIC NOISE	dB(A)	50 (at distance of 5 cm from motor)

CONNECTOR

LEAD WIRE	-	UL-1061, AWG #26
-----------	---	------------------

ROTATION

DIRECTION	CW	(facing at shaft)
-----------	----	-------------------

CONNECTOR PIN ASSIGNMENT

NO.	FUNCTION	COLOR
1	Vcc	Black
2	Vs	Black
3	GND	Gray

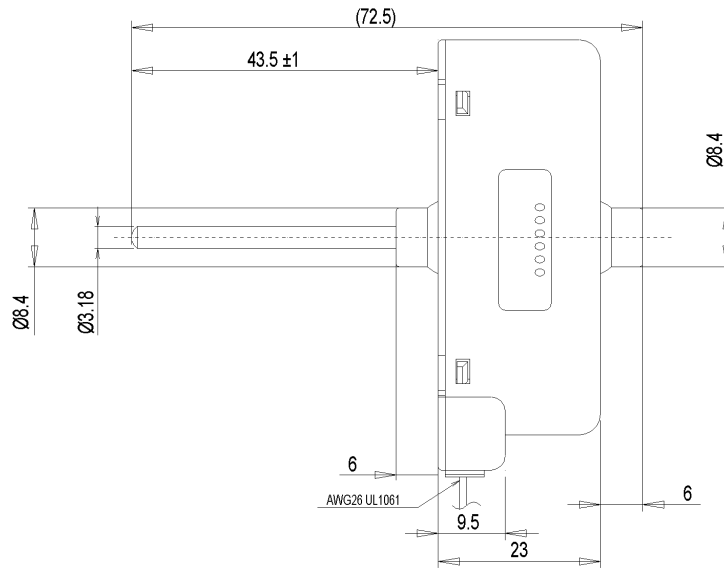
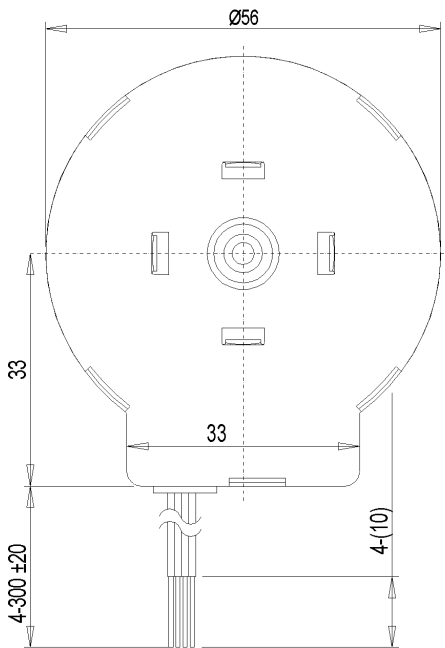

SPEED-TORQUE CHARACTERISTICS

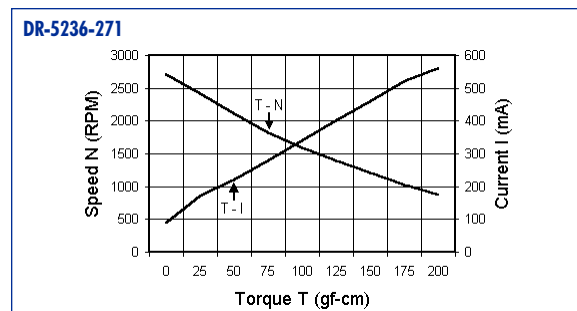



CONNECTOR PIN ASSIGNMENT

NO.	FUNCTION
1	VDC: 24 V
2	GND
3	On/Off (Low Start)
4	Lock Signal: Open Collector

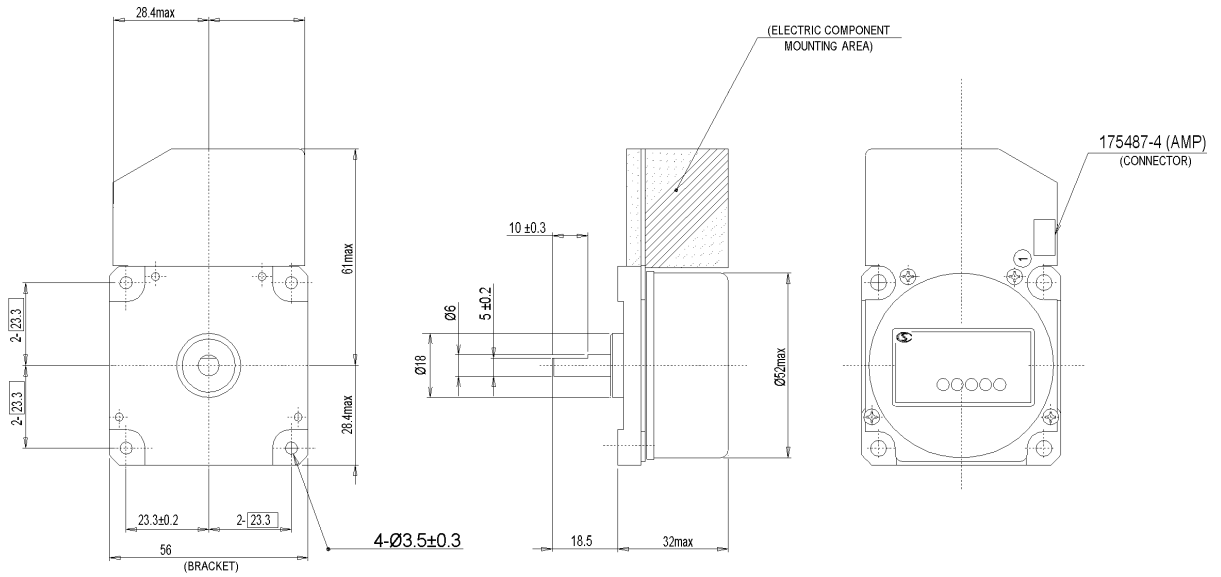

SPECIFICATION

ELECTRICAL CHARACTERISTICS

RATED POWER	W	5.1
RATED VOLTAGE	VDC	24
RATED LOAD	N-cm gf-cm	4.9 500
RATED SPEED	rpm	1,000 ± 1% (controlled)
RATED CURRENT	mA (max.)	750
BREAKDOWN TORQUE	gf-cm (min.)	550 (at 21.6 V)
NO LOAD SPEED	rpm	1,000
LIFE	hours (typical)	10,000 (at rated load, voltage)
ACOUSTIC NOISE	dB(A)	50 (at distance of 1 m)
TEMPERATURE RISE	C (max.)	50 (at rated load, voltage)

CONNECTOR

HEADER	-	AMP p/n 175487-4 (white)
--------	---	--------------------------

ROTATION

DIRECTION	CCW	(facing at shaft)
-----------	-----	-------------------

SPEED-TORQUE CHARACTERISTICS

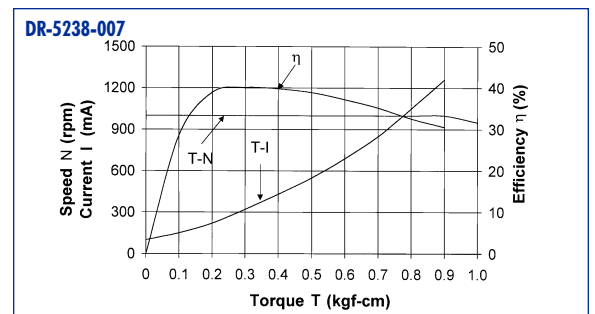



SPECIFICATION

ELECTRICAL CHARACTERISTICS

RATED VOLTAGE	VDC	36
RATED LOAD	N-cm gf-cm	0.98 100
RATED SPEED	rpm	4,200 ± 10%
RATED CURRENT	mA (max.)	300
NO LOAD SPEED	rpm	5,500 ± 10% (reference)
LIFE	hours (typical)	10,000 (ball bearing life at rated speed, rated load)
ROTOR INERTIA	g-cm ²	16 (reference)
TEMPERATURE RISE	C (max.)	90 (at rated load, rated voltage)
HALL SENSOR	-	open collector output
DC RESISTANCE	Ω	28 ± 10% (line to line)
INDUCTANCE	mH	18 (nominal, line to line)

CONNECTOR

HOUSING	-	AMP #104257-7 (black)
CONTACT	-	AMP #104480-3
CABLE	-	UL-1061, AWG #24

CONNECTOR PIN ASSIGNMENT

NO.	FUNCTION	COLOR
1	VDC: 5 V	Green
2	GND	Blue
3	Hall A	White
4	Hall B	Brown
5	Hall C	Black
6	Coil C	Yellow
7	Coil B	Orange
8	Coil A	Red

Timing Diagram

CCW ROTATION (VIEWED FROM OUTPUT SHAFT SIDE)

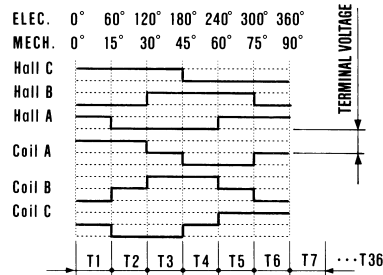

CW ROTATION

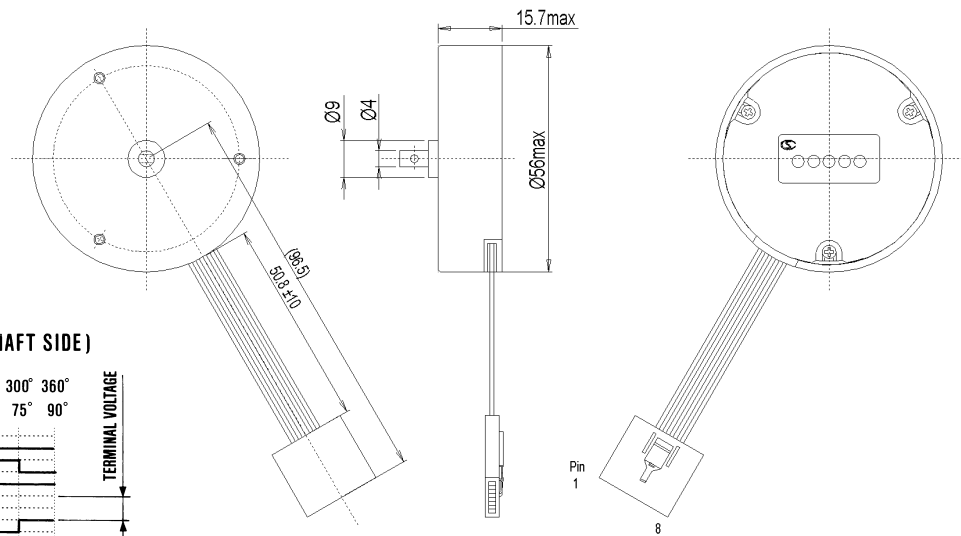
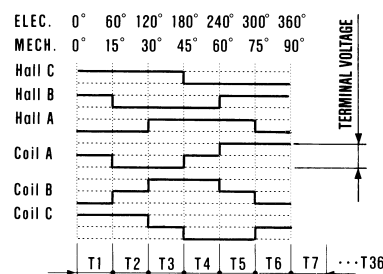

SPEED-TORQUE CHARACTERISTICS

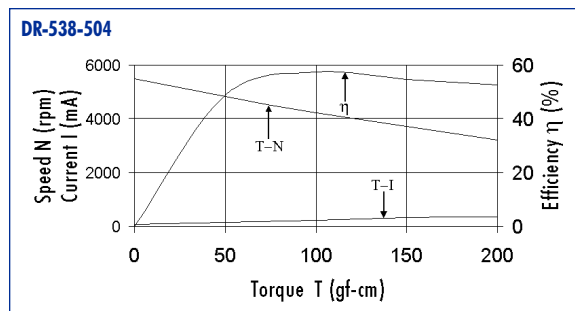

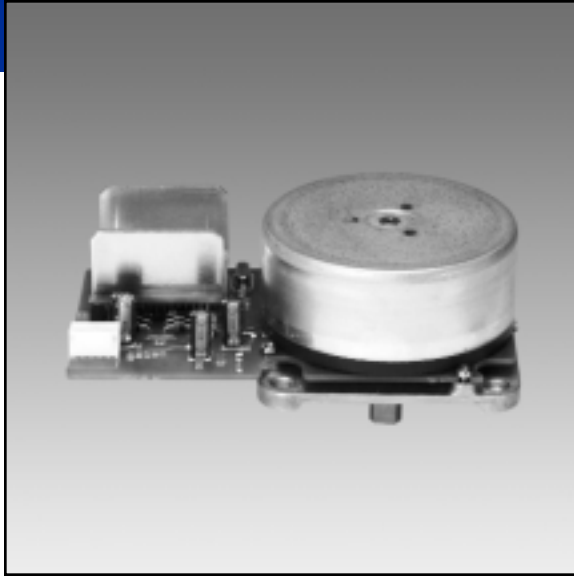

CONNECTOR PIN ASSIGNMENT

NO.	FUNCTION
1	VDC: 24 V
2	GND
3	On/Off (Low Start)
4	Lock Signal: Open Collector

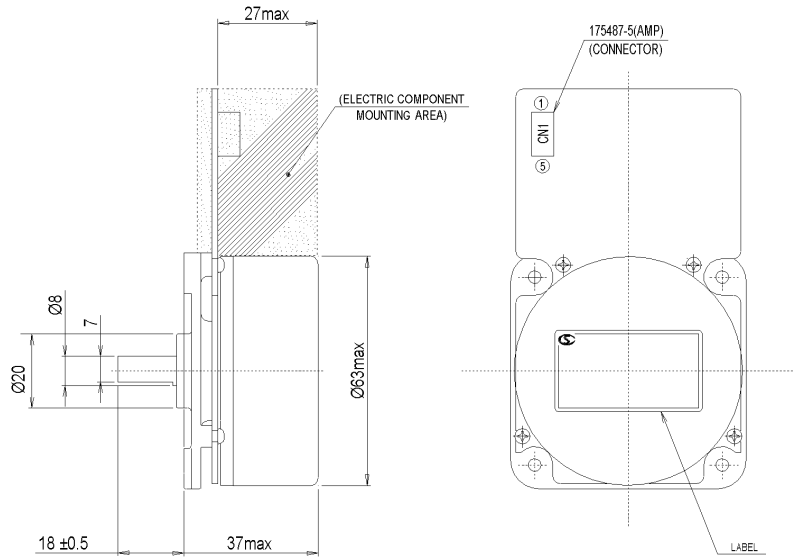
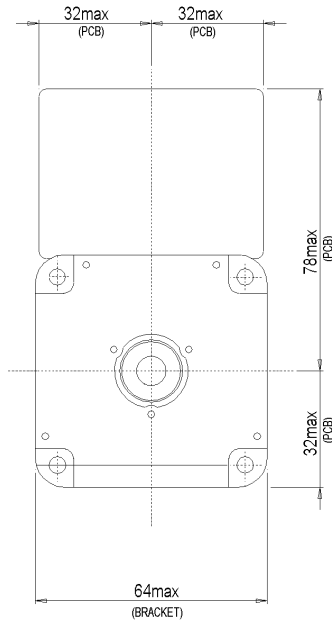

SPECIFICATION

ELECTRICAL CHARACTERISTICS

RATED POWER	W	15
RATED VOLTAGE	VDC	24
RATED LOAD	N-cm kgf-cm	9.8 1
RATED SPEED	rpm	1,500 ± 0.1% (controlled)
RATED CURRENT	A (max.)	1.4
BREAKDOWN TORQUE	N-cm (min.) gf-cm (min.)	9.3 (at 21.6 V) 950 (at 21.6 V)
NO LOAD SPEED	rpm	1,500
LIFE	hours (typical)	10,000 (at rated load, rated voltage)
ACOUSTIC NOISE	dB(A) (max.)	45 (at distance of 1 m)
TEMPERATURE RISE	C (max.)	65 (at rated load, rated voltage)

CONNECTOR

HEADER	-	AMP p/n 175487-5 (white)
--------	---	--------------------------

ROTATION

DIRECTION	CCW	(facing at shaft)
-----------	-----	-------------------

SPEED-TORQUE CHARACTERISTICS

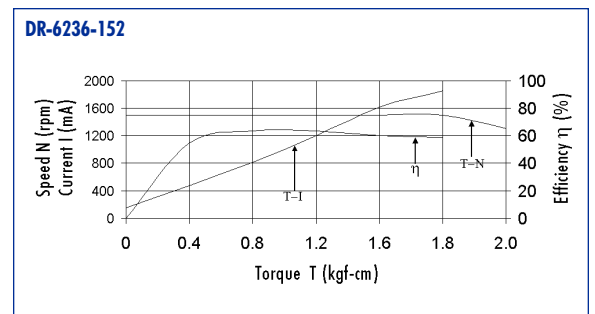



SPECIFICATION

ELECTRICAL CHARACTERISTICS		
RATED VOLTAGE	VDC	7 to 40 (operating range)
VCC	VDC	12 ± 1.2 (logic level)
RATED LOAD	gf-cm	110
RATED SPEED	rpm	3,200 ± 320 (at 26.5 V)
RATED CURRENT	A (max.)	0.35 (at 26.5 V)
NO LOAD SPEED	rpm	3,850 (nominal)
LIFE	hours (typical)	10,000 (at less than 45 C ambient)
ENCODER		
TYPE	-	magnetic encoder
RESOLUTION	pulse/rev.	2
OUTPUT LEVEL	V (high) V (low)	11.0 ± 1.0 0 to 0.5
DUTY CYCLE	%	66.7 ± 20
WINDING RESISTANCE	Ω	5.4 (nominal)
CONNECTOR		
	-	JST p/n S4B-EH
ROTATION		
DIRECTION	CCW	(facing at shaft)

CONNECTOR PIN ASSIGNMENT

NO.	FUNCTION
1	Encoder Out
2	VCC: 12 V
3	GND
4	VDC: 7 to 40 V

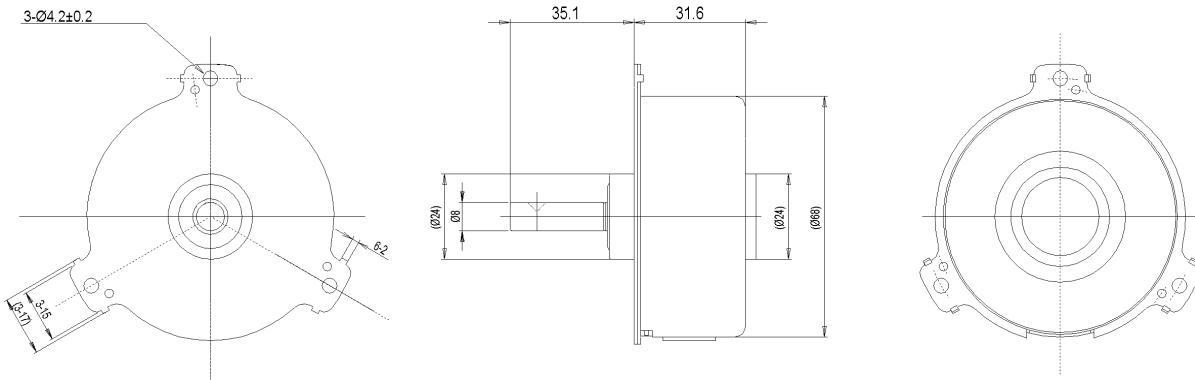

SPEED-TORQUE CHARACTERISTICS

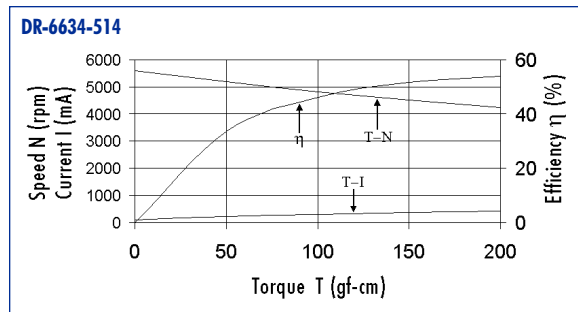

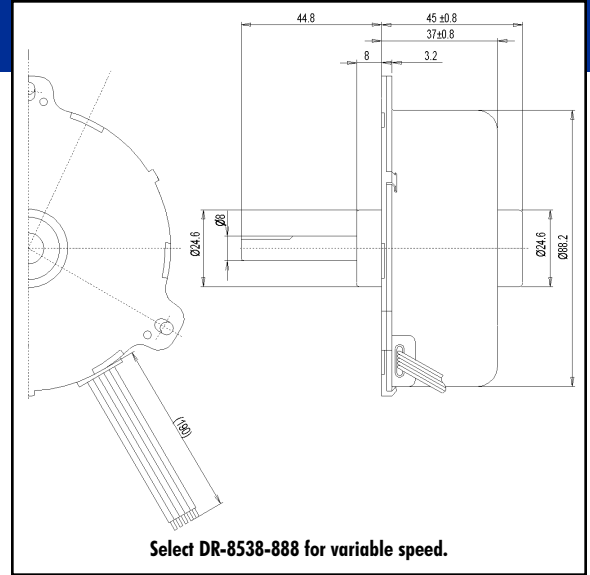

Select DR-8538-888 for variable speed.

SPECIFICATION

ELECTRICAL CHARACTERISTICS		DR-8538-555	DR-8538-888
RATED VOLTAGE	VDC	10 to 40 (operating range)	90 to 178 (operating voltage)
VCC	VDC	12 ± 1.2 (logic level)	15 ± 1.5 (logic level)
RATED LOAD	gf-cm	1,200	1,400
RATED SPEED	rpm	2,000 ± 250 (at 34 V)	2,700 ± 300 (at 160 V)
RATED CURRENT	A (max.)	1.4 (at 34 V)	0.44 (at 160 V)
SPEED CONTROL INPUT	V	-	0 to 6.5
NO LOAD SPEED	rpm	3,000 (nominal)	4,000 (nominal)
NO LOAD CURRENT	mA	200 (nominal)	50 (nominal)
TORQUE CONSTANT	g-cm/A	1,250	4,550 (nominal)
LIFE	hours (min.)	10,000 (at less than 45 C ambient)	10,000 (at less than 45 C ambient)
ENCODER			
TYPE	-	magnetic encoder	magnetic encoder
RESOLUTION	pulse/rev.	4	12
OUTPUT LEVEL	V (high) V (low)	11.0 ± 1.0 0 to 0.5	14.0 ± 1.0 0 to 1.0
DUTY CYCLE	%	66.7 ± 20	50 ± 20
CONNECTOR			
NONE	-	(flying wires)	(flying wires)
LEAD WIRE	-	UL-1430, AWG #22	UL-1430, AWG #22
ROTATION			
DIRECTION	CCW	(facing at shaft)	(facing at shaft)

CONNECTOR PIN ASSIGNMENT

DR-8538-555

NO.	FUNCTION	COLOR
1	VDC: 10 to 40 V	Red
2	GND	White
3	VCC: 12 V	Yellow
4	Encoder Out	Blue

CONNECTOR PIN ASSIGNMENT

DR-8538-888

NO.	FUNCTION	COLOR
1	VDC: 90 to 178 V	Red
2	GND	Black
3	VCC: 15 V	White
4	VDC: 0 to 6.5 V	Yellow
5	Encoder Out	Blue

SPEED-TORQUE CHARACTERISTICS

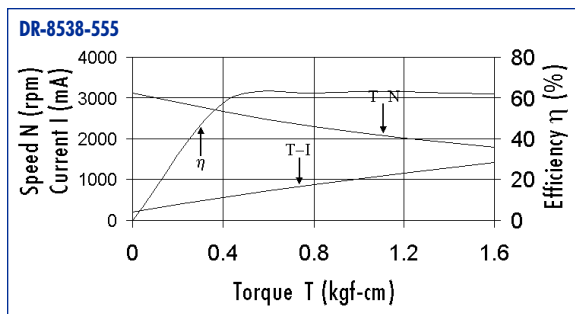

SPEED-TORQUE CHARACTERISTICS

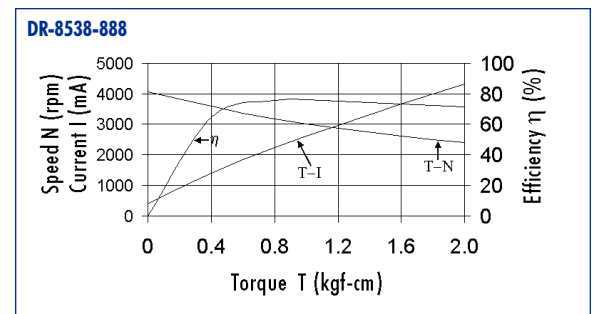

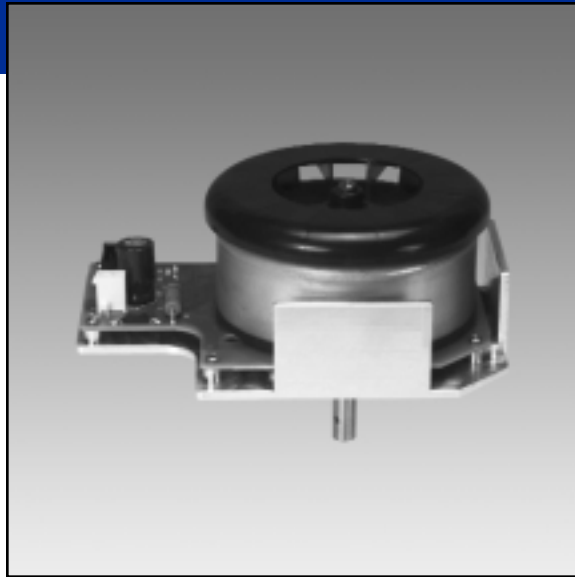

SPECIFICATION

ELECTRICAL CHARACTERISTICS

RATED VOLTAGE	VDC	24
VCC	VDC	5
RATED LOAD	N·m	0.343
	kgf·cm	3.5
RATED SPEED	rpm	1,500 ± 0.1% (controlled)
RATED CURRENT	A (max.)	5.0
BREAKDOWN TORQUE	N·cm (min.)	0.39 (at 21.6 V)
	kgf·cm (min.)	4.0 (at 21.6 V)
NO LOAD SPEED	rpm	1,500
LIFE	hours (typical)	10,000 (at rated voltage, rated load)
ACOUSTIC NOISE	dB(A) (max.)	45 (at distance of 1 m)
TEMPERATURE RISE	C (max.)	75 (at rated load, rated voltage)

CONNECTOR

HEADER	-	AMP p/n 53053-0610 (white)
--------	---	----------------------------

ROTATION

DIRECTION	CCW	(facing at shaft)
-----------	-----	-------------------

CONNECTOR PIN ASSIGNMENT

NO.	FUNCTION
1	VDC: 24 V (coil)
2	GND (VDC)
3	GND (VCC)
4	VCC: 5 V (logic)
5	On/Off (Low Start)
6	Lock Signal: Open Collector

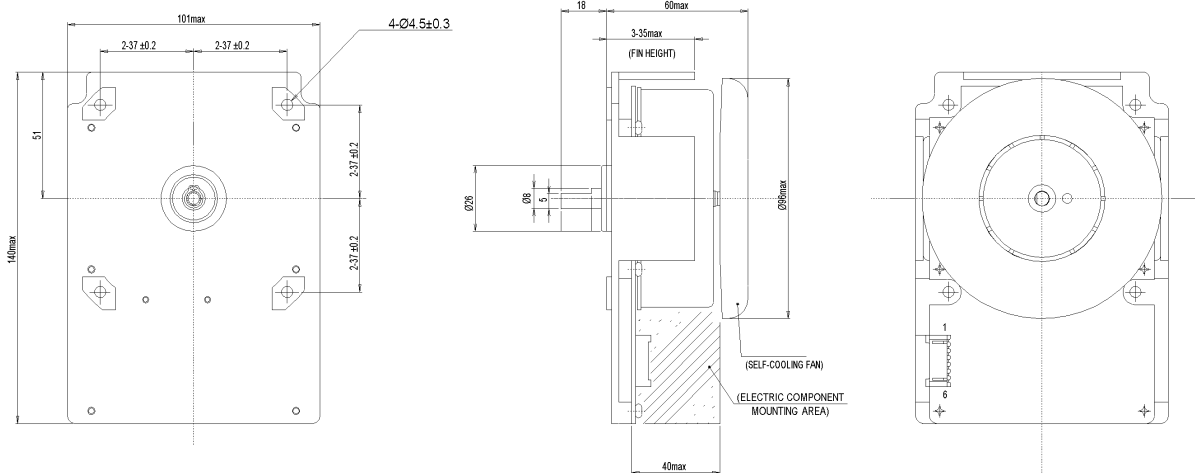

SPEED-TORQUE CHARACTERISTICS

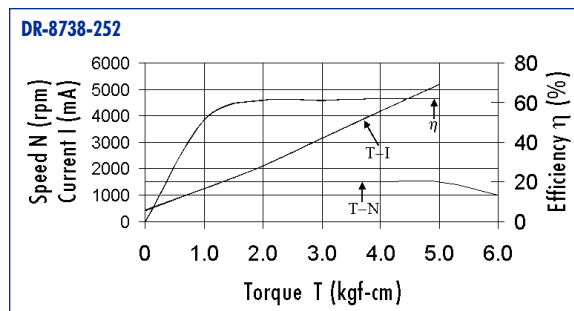

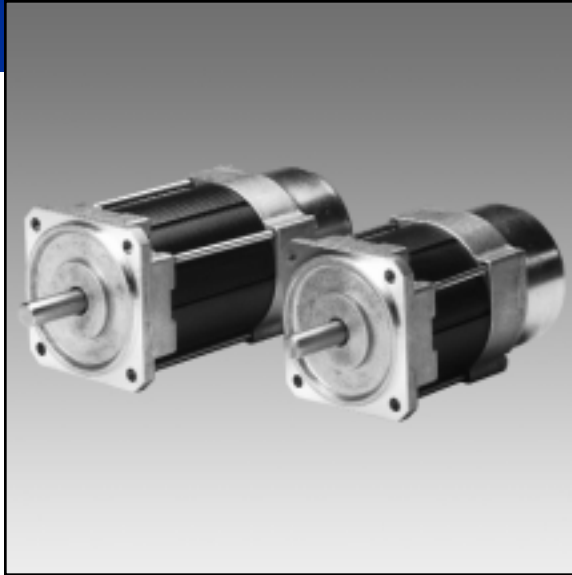

SPECIFICATION

PARAMETER	UNITS	LA052-040E		LA052-080E		LA052-110E
RATED POWER	W	40		80		110
RATED VOLTAGE	VDC	24	75	24	75	75
RATED SPEED	rpm	3,000		3,000		3,000
RATED TORQUE	N-cm	12.7	12.7	25.5	25.5	35.3
	kgf-cm	1.3	1.3	2.6	2.6	3.6
RATED CURRENT	A	2.5	0.9	4.6	1.8	2.1
TORQUE CONSTANT	N-cm/A	5.0	14.8	5.9	19.1	19.6
	kgf-cm/A	0.51	1.51	0.6	1.95	2.00
BACK EMF CONSTANT	V/krpm	5.2	15.5	6.2	20.0	20.5
PHASE RESISTANCE	W	1.18	11.0	0.60	6.2	3.71
PHASE INDUCTANCE	mH	4.4	42	1.4	14	9.1
INSTANTANEOUS PEAK TORQUE	N-cm	38.2	38.2	76.5	76.5	105.9
	kgf-cm	3.9	3.9	7.8	7.8	10.8
MAX SPEED	rpm	5,000	5,000	5,000	5,000	5,000
ROTOR INERTIA (TYPE 2*)	g-cm ²	87	87	91	91	166
	g-cm ²	110	110	117	117	18
POWER RATE (TYPE 2*)	kW/s	1.87	1.87	7.14	7.14	8.48
	kW/s	1.48	1.48	5.56	5.56	6.74
MECHANICAL TIME CONSTANT (TYPE 2*)	ms	4.1	4.4	4.6	1.5	1.6
	ms	5.2	5.5	2.0	2.0	1.8
ELECTRICAL TIME CONSTANT	ms	3.7	3.8	2.3	2.3	2.5
MASS	kg	0.6	0.6	0.6	0.6	0.8

The above values are measured with Aluminum Plate of 200 x 200 x 6 mm

* See Encoder Specification below

ENCODER SPECIFICATION

TYPE	UNITS	TYPE 1	TYPE 2	
		PULL UP AT 4.7 [kΩ]	HALL SENSOR OPEN COLLECTOR	ENCODER TTL COMPATIBLE
RESOLUTION	P/R	500	-	200, 400
NUMBER OF CHANNELS	-	6 (A, B, Z, C1, C2, C3)	C1, C2, C3	A, B
POWER SUPPLY	VDC	5 ± 5%	5 ± 5%	5 ± 5%
CONSUMPTION CURRENT	mA (max.)	100	40	50
OUTPUT VOLTAGE	VDC	VOH = 2.4 (min.), VOL = 0.4 (max.), (Isink = 4 mA)	14.4 (max.), (Isink = 15 mA)	VOH = 2.4 (min.), VOL = 0.4 (max.), (Isink = 15 mA)
PHASE OFFSET	-	a, b, c, d = 90° ± 45°	-	a, b, c, d = 90° ± 45°
SIG. Z PULSE WIDTH	-	360° ± 180°	-	-
FREQUENCY RESPONSE	kHz (min.)	50	-	20
OPERATING TEMPERATURE RANGE	°C	0 ~ 60 (temperature inside of encoder)		

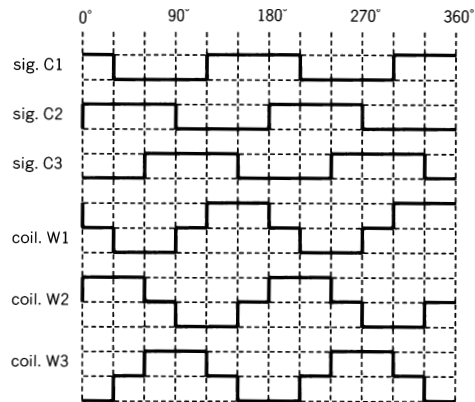
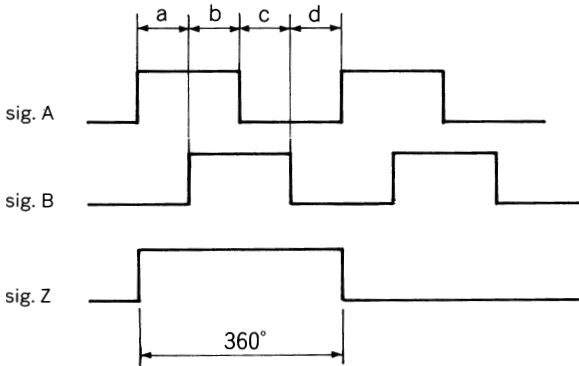
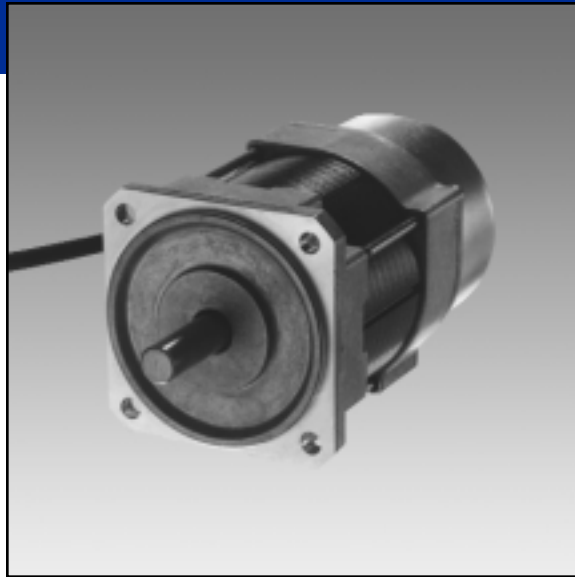

→ CW ROTATION VIEWED FROM OUTPUT SHAFT END
ENCODER OUTPUT PHASE

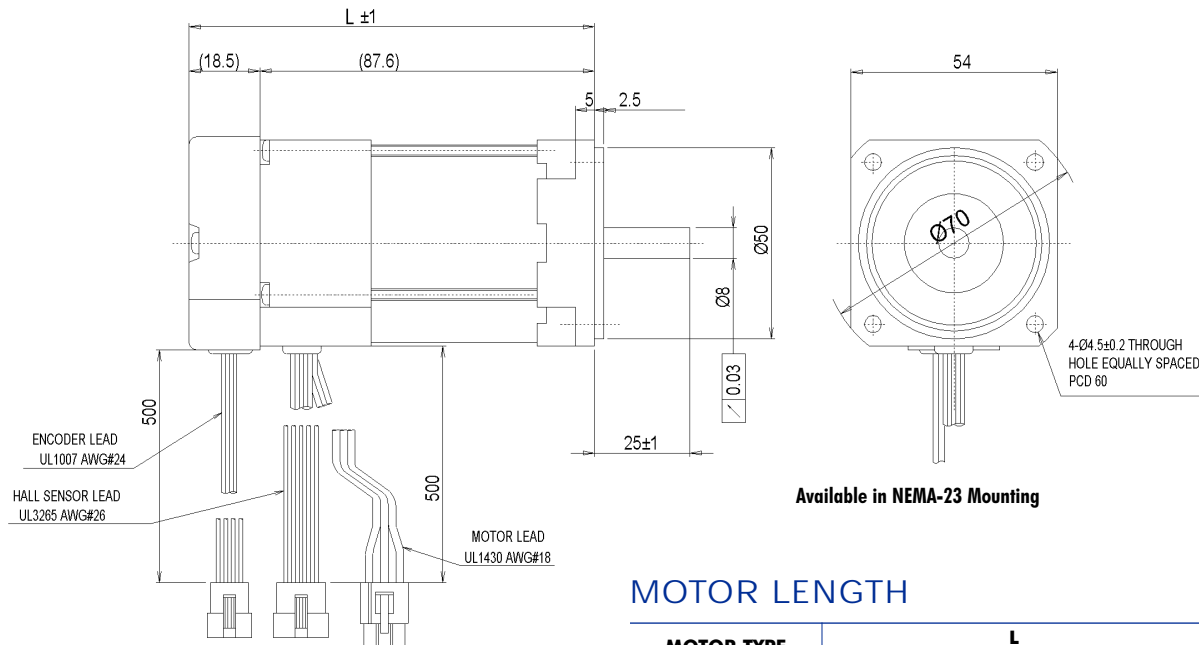

Available in NEMA-23 Mounting

MOTOR LENGTH

MOTOR TYPE	L	
	TYPE 1*	TYPE 2*
LA052-040E	85	86.1
LA052-080E	85	86.1
LA052-110E	105	106.1

* See Encoder Specification on previous page

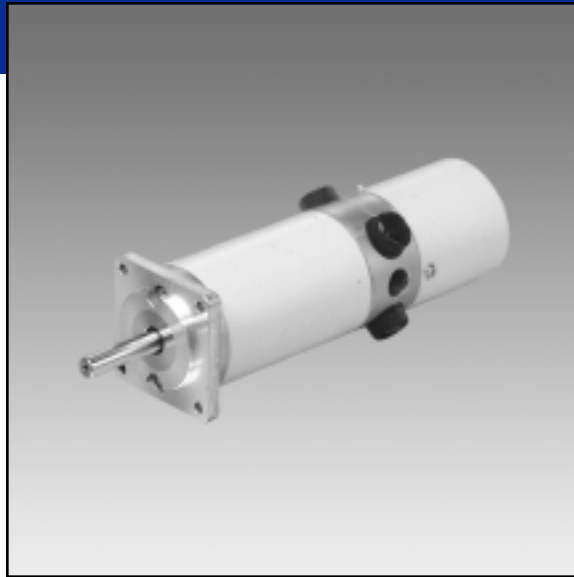

SPECIFICATION

PARAMETER	UNITS	DH038-020E	DH038-030E		DH052-060E		DH052-120E	DH072-200E	DH072-300E
RATED POWER	W	20	30		60		120	200	300
RATED VOLTAGE	VDC	24	24	75	24	75	75	75	75
RATED SPEED	rpm	3,000	3,000		3,000		3,000	3,000	3,000
RATED TORQUE	N·m kgf·cm	0.064 0.65	0.0981 1	0.0981 1	0.191 1.95	0.191 1.95	0.383 3.9	0.637 6.5	0.981 10
RATED CURRENT	A	1.5	1.9	0.8	3.5	1.2	2.2	3.4	5
TORQUE CONSTANT	N·m/A kgf·cm/A	0.055 0.56	0.057 0.582	1.68 1.71	0.059 0.6	0.185 1.89	0.196 2	0.206 2.1	0.204 2.08
BACK EMF CONSTANT	V·s/rad V/krpm	0.055 5.74	0.057 5.98	0.168 17.6	0.059 6.14	0.185 19.4	0.196 20.5	0.206 21.6	0.204 21.3
ARMATURE RESISTANCE	Ω	4.5	2.6	28.6	1.5	13.6	6.5	2.4	2.1
ARMATURE INDUCTANCE	mH	1.5	0.9	8.7	0.7	6.2	3.2	1.7	1.1
INSTANTANEOUS PEAK TORQUE	N·cm kgf·cm	0.353 3.6	0.54 5.5	0.54 5.5	1.05 10.7	1.05 10.7	2.11 21.5	3.51 35.8	5.39 55
INSTANTANEOUS MAX CURRENT	A	6.4	9.5	3.2	17.8	5.7	10.8	16.1	26.5
MAX SPEED	rpm	4,500	4,500	4,500	4,000	4,000	4,000	4,000	4,000
ROTOR INERTIA	kg·m ² g·cm ⁻²	3.1 × 10 ⁻⁴ 0.032	5.88 × 10 ⁻⁴ 0.06	5.88 × 10 ⁻⁴ 0.06	1.73 × 10 ⁻⁴ 0.176	1.73 × 10 ⁻⁴ 0.176	3.71 × 10 ⁻⁴ 0.378	1.57 × 10 ⁻⁴ 1.6	2.45 × 10 ⁻⁴ 2.51
POWER RATE	kW/s	1.3	1.63	1.63	2.11	2.11	3.95	2.58	3.93
MECHANICAL TIME CONSTANT	ms	4.7	3.9	6	6.6	6.8	6.3	8.87	12.2
ELECTRICAL TIME CONSTANT	ms	0.33	0.34	0.3	0.44	0.45	0.49	0.71	0.52
ROTOR INERTIA	N·m kgf·cm	0.011 0.11	0.012 0.12	0.012 0.12	0.0157 0.16	0.0157 0.16	0.0274 0.28	0.054 0.55	0.069 0.7
WEIGHT	kgf	0.4	0.45	0.45	0.8	0.8	1.3	2.2	3.1
ENCODER	-	STANDARD INCREMENTAL ENCODER							
BRAKE									
RATED VOLTAGE	VDC	24	24	24	24	24	24	24	-
CONSUMPTION POWER	W	4	4	4	7	7	7	7.7	-
STATIC FRICTION TORQUE	N·m kgf·cm	0.15 (min.) 1.5 (min.)	0.15 (min.) 1.5 (min.)	0.15 (min.) 1.5 (min.)	0.49 (min.) 5 (min.)	0.49 (min.) 5 (min.)	0.49 (min.) 5 (min.)	1.47 (min.) 15 (min.)	-

The values above are measured with the following aluminum plate. DH038 : 150 x 150 x t6, DH052 : 200 x 200 x t6, DH072 : 250 x 250 x t12

Armature resistance is including brush contact resistance.

Periodical cleaning of brush is recommended

ENCODER SPECIFICATION

OUTPUT CIRCUIT	UNITS	PULL UP AT 4.7 [kΩ]	LINE DRIVER	OPEN COLLECTOR
RESOLUTION	P/R		500, 1000, 2000	
NUMBER OF CHANNELS	-		3 (2000 P/R NOT HAVE sig. Z)	
POWER SUPPLY	VDC		5 ± 5%	
CONSUMPTION CURRENT	mA (max.)	100	200	100
OUTPUT VOLTAGE	VDC	VOH = 2.4 (min.), VOL = 0.4 (max.)	VOH = 2.4 (min.), VOL = 0.4 (max. at 20 mA)	40
PHASE OFFSET	-		a, b, c, d = 90° ± 45°	
SIG. Z PULSE WIDTH	-		360° ± 180°	
FREQUENCY RESPONSE	kHz (min.)		500 : P/R = 40, 1000 : P/R = 75, 2000 : P/R = 100	
OPERATING TEMPERATURE RANGE	°C		0 ~ 70 (temperature inside of encoder)	

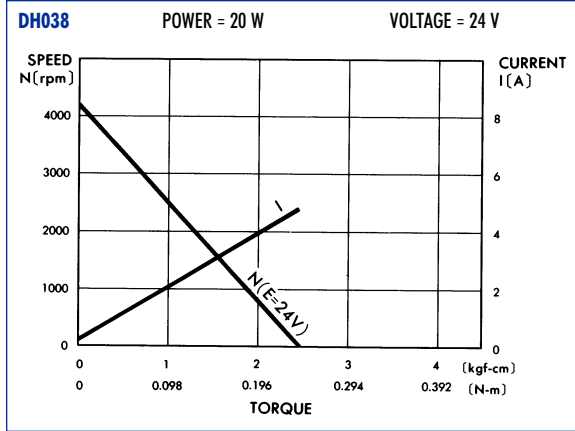
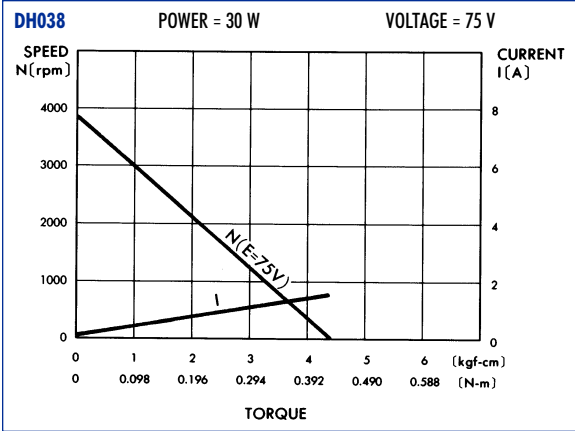
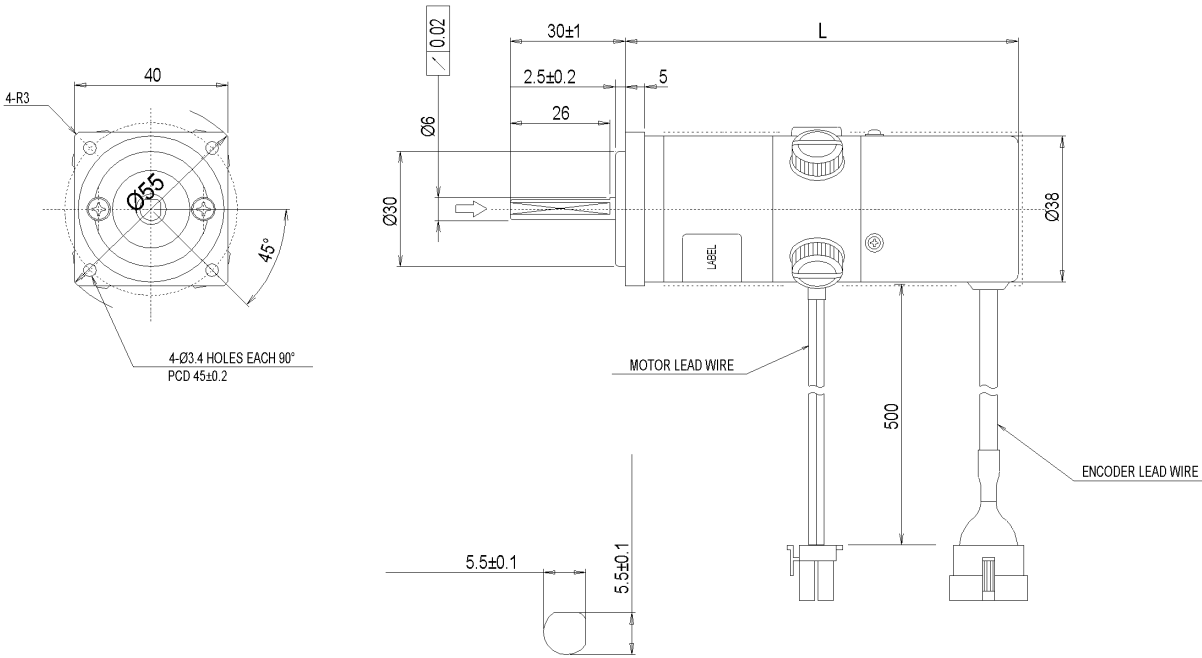

MOTOR LENGTH

MOTOR TYPE	L
20 W (STAND.)	91
30 W (STAND.)	101
20 W (BRAKE)	123
30 W (BRAKE)	134

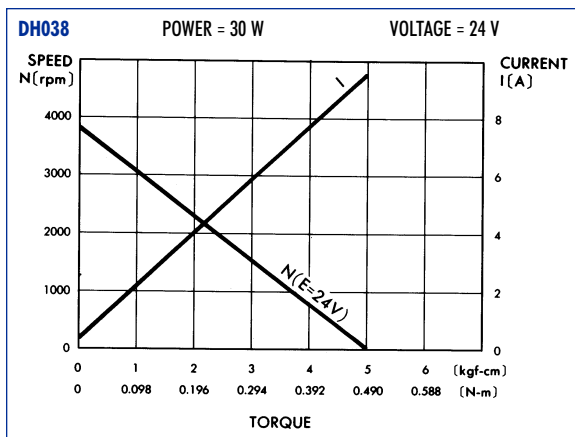

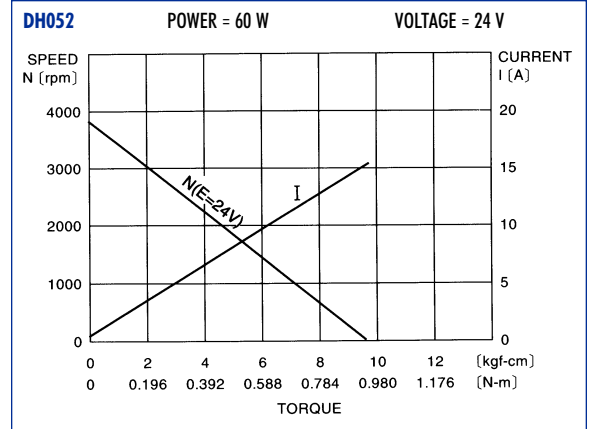
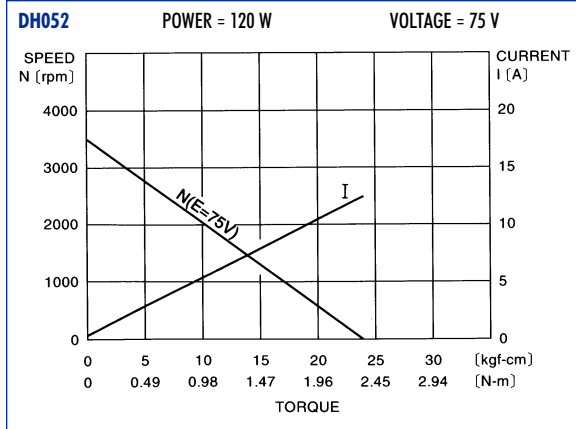
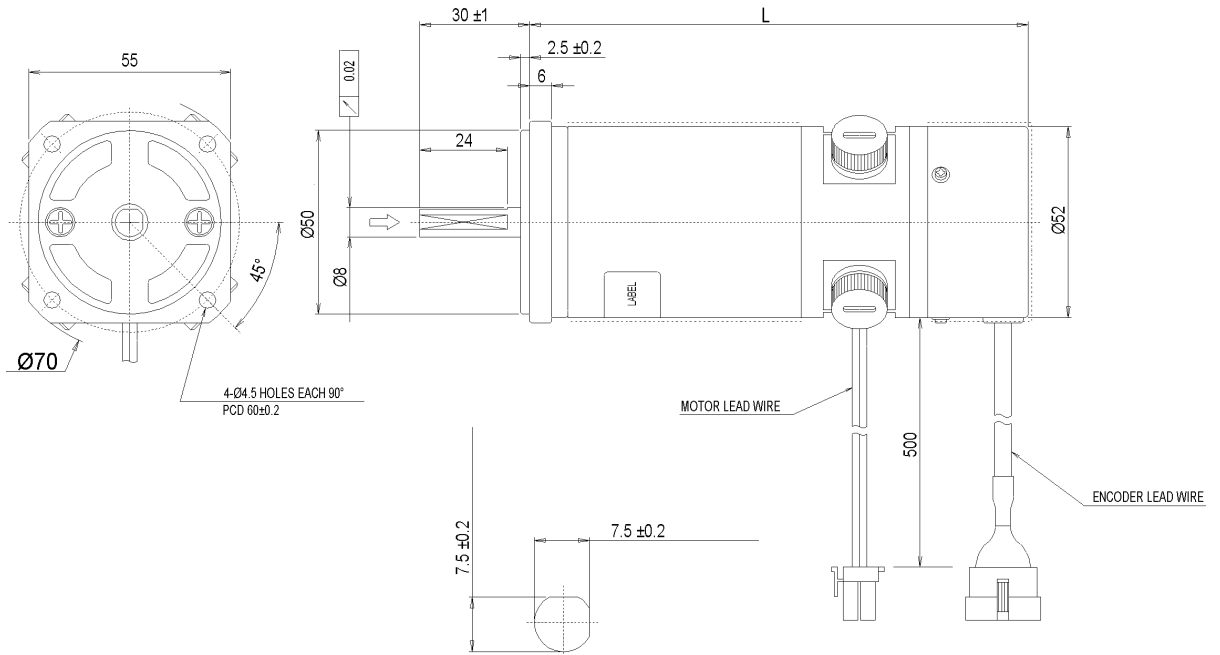

MOTOR LENGTH

MOTOR TYPE	L
60 W (STAND.)	100
120 W (STAND.)	136
60 W (BRAKE)	130
120 W (BRAKE)	166

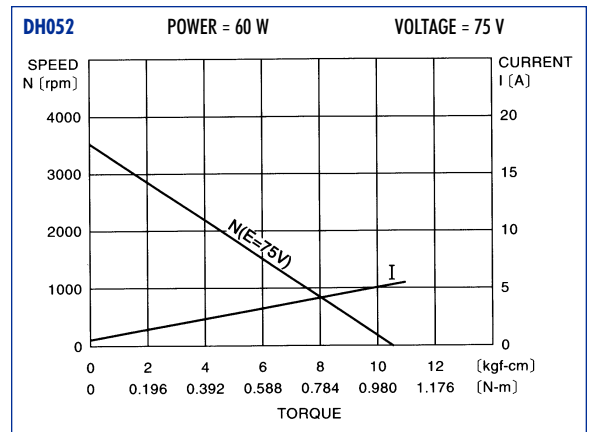

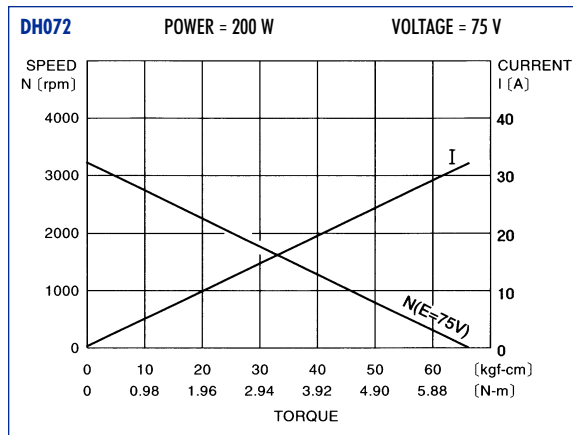
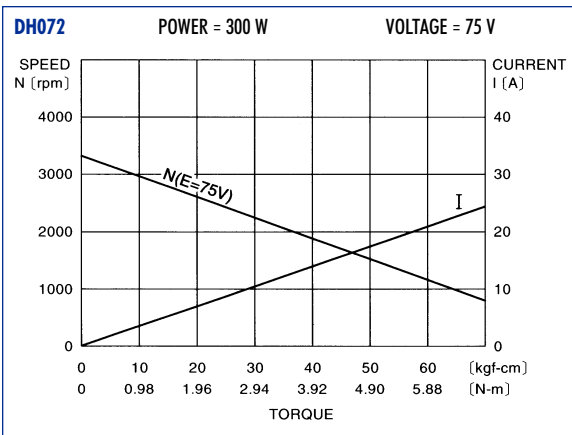
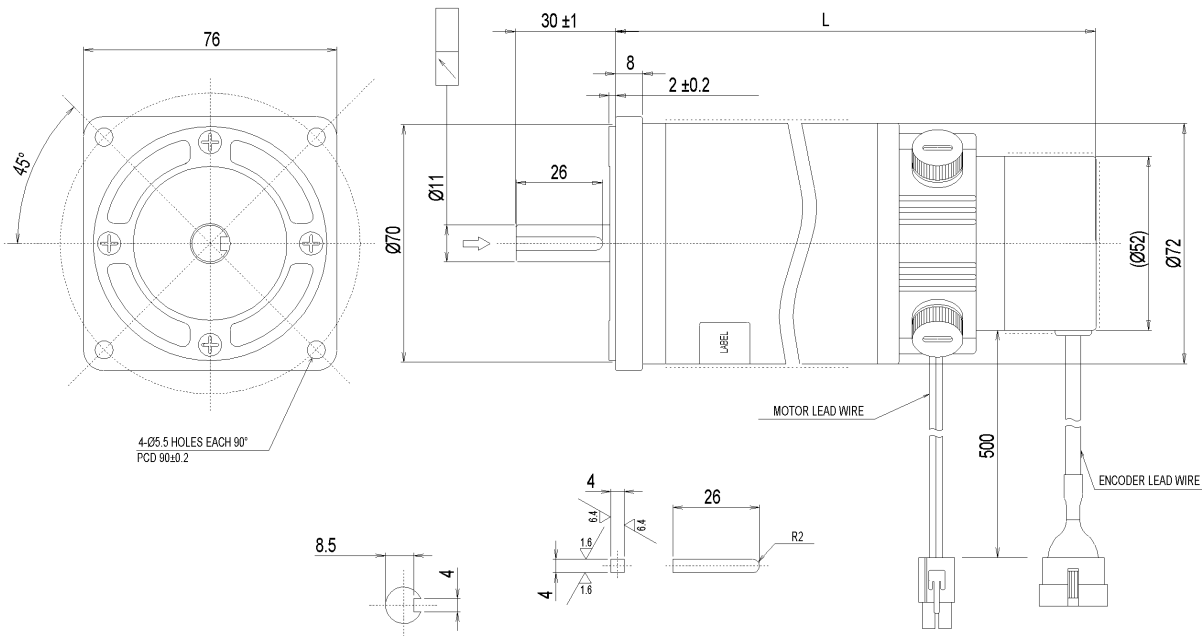

MOTOR LENGTH

MOTOR TYPE	L
200 W (STAND.)	136
300 W (STAND.)	163
200 W (BRAKE)	174

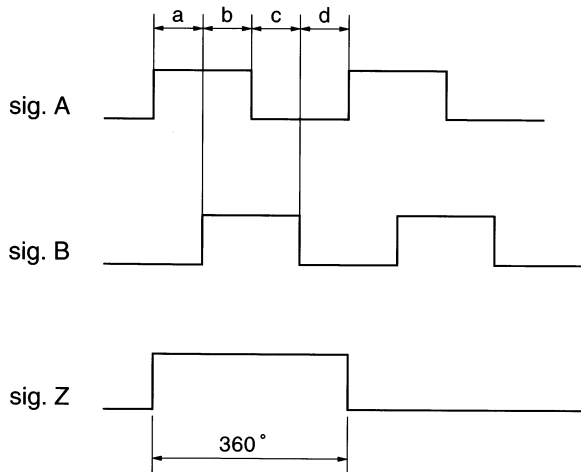
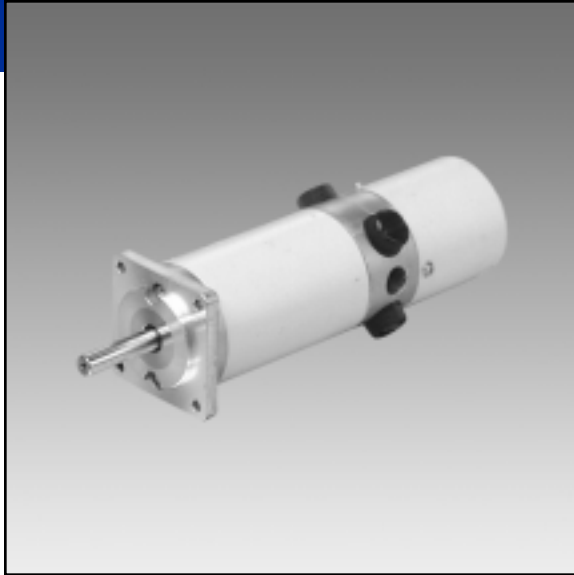

a) PULL UP AT 1[kΩ]
OPEN COLLECTOR

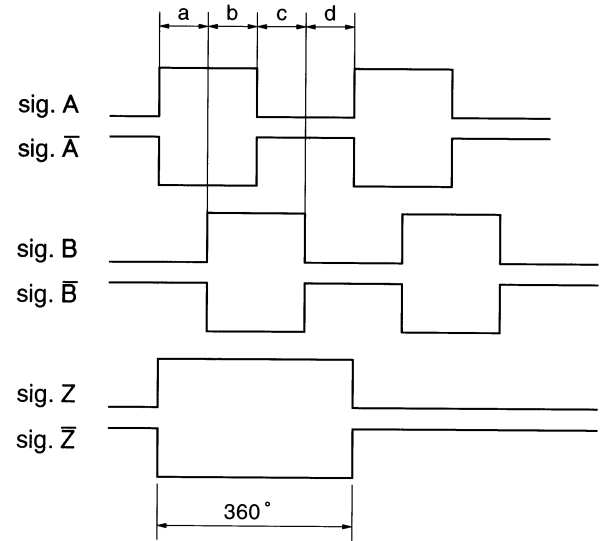

b) LINE DRIVER

→ CW ROTATION VIEWED FROM OUTPUT SHAFT END
ENCODER OUTPUT PHASE

THE NAME OF MOTOR _____

DH000-000E00

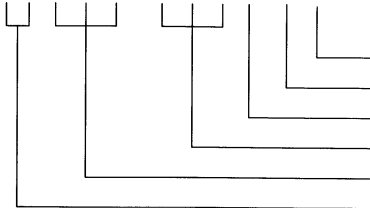

- B:W/BRAKE N:W/O BRAKE
- ENCODER PULSE
- B:W/ ENCODER N:W/O ENCODER
- RATED POWER
- DIAMETER OUTSIDE
- THE NAME OF SERIES

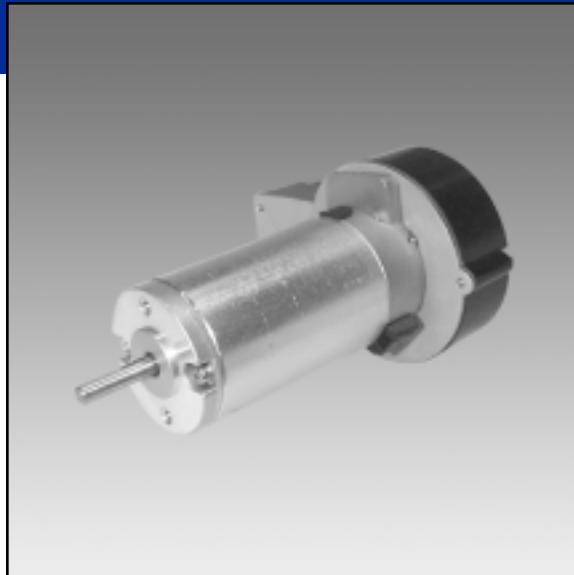

SPECIFICATION

PARAMETER	UNITS	DX038-015E	DX050-020E	DX050-025E
RATED POWER	W	15	20	25
RATED VOLTAGE	VDC	24	24	24
RATED SPEED	rpm	2,000	2,000	2,000
RATED TORQUE	N-m kgf-cm	0.074 0.75	0.098 1	0.123 1.25
RATED CURRENT	A	1.1	1.4	1.6
TORQUE CONSTANT	N-m/A kgf-cm/A	0.085 0.87	0.084 0.86	0.087 0.89
BACK EMF CONSTANT	V-s/rad V/krpm	0.085 8.9	0.084 8.8	0.087 9.1
ARMATURE RESISTANCE	Ω	6.3	4.6	3.6
ARMATURE INDUCTANCE	mH	4.2	2.9	2.93
INSTANTANEOUS PEAK TORQUE	N-m kgf-cm	0.41 4.2	0.54 5.5	0.68 6.9
INSTANTANEOUS MAX. CURRENT	A	5.1	7.1	8.1
MAX. SPEED	rpm	3,000	3,000	3,000
ROTOR INERTIA	kg-m ² g-cm-s ²	0.96 x 10 ⁻⁵ 0.098	1.02 x 10 ⁻⁵ 0.165	2.21 x 10 ⁻⁵ 0.225
POWER RATE	kW/s	0.56	0.59	0.68
MECHANICAL TIME CONSTANT	ms	8.36	10.6	10.5
ELECTRICAL TIME CONSTANT	ms	0.65	0.62	0.62
FRICTION TORQUE	N-m kgf-cm	0.098 0.1	0.02 0.2	0.016 0.16
WEIGHT	kgf	0.42	0.6	0.65
ENCODER	-	STANDARD INCREMENTAL ENCODER		

ENCODER SPECIFICATION

OUTPUT CIRCUIT	UNITS	PULL UP AT 4.7 [k Ω]
RESOLUTION	P/R	144, 150, 200, 240, 288, 400
NUMBER OF CHANNELS	-	2
POWER SUPPLY	VDC	5 \pm 5%
CONSUMPTION CURRENT	mA (max.)	50
OUTPUT VOLTAGE	VDC	VOH = 2.4 (min.), VOL = 0.4 (max.), (I sink = 3.2 mA)
PHASE OFFSET	-	a, b, c, d = 90° \pm 45°
FREQUENCY RESPONSE	kHz (min.)	20
OPERATING TEMPERATURE RANGE	°C	0 ~ 70 (temperature inside of encoder)

MODEL
DX038-015E

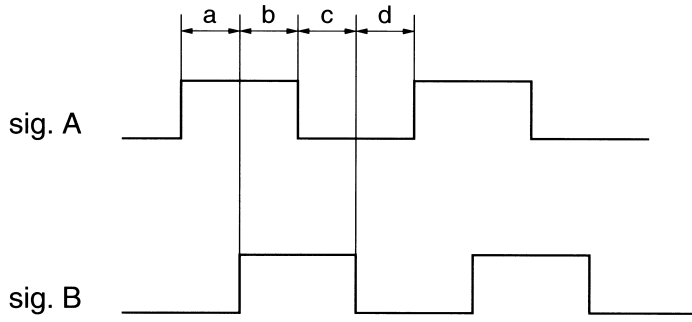

→ CW ROTATION VIEWED FROM OUTPUT SHAFT END
ENCODER OUTPUT PHASE

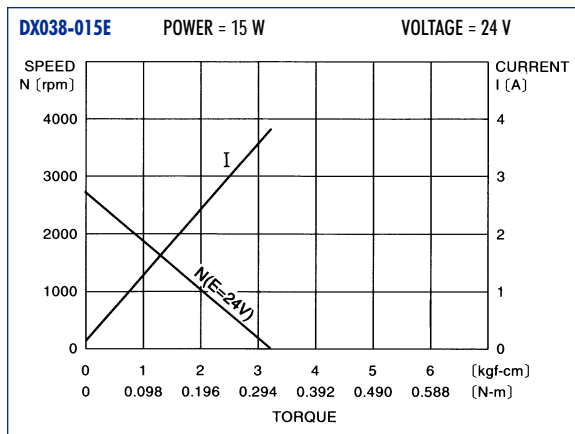
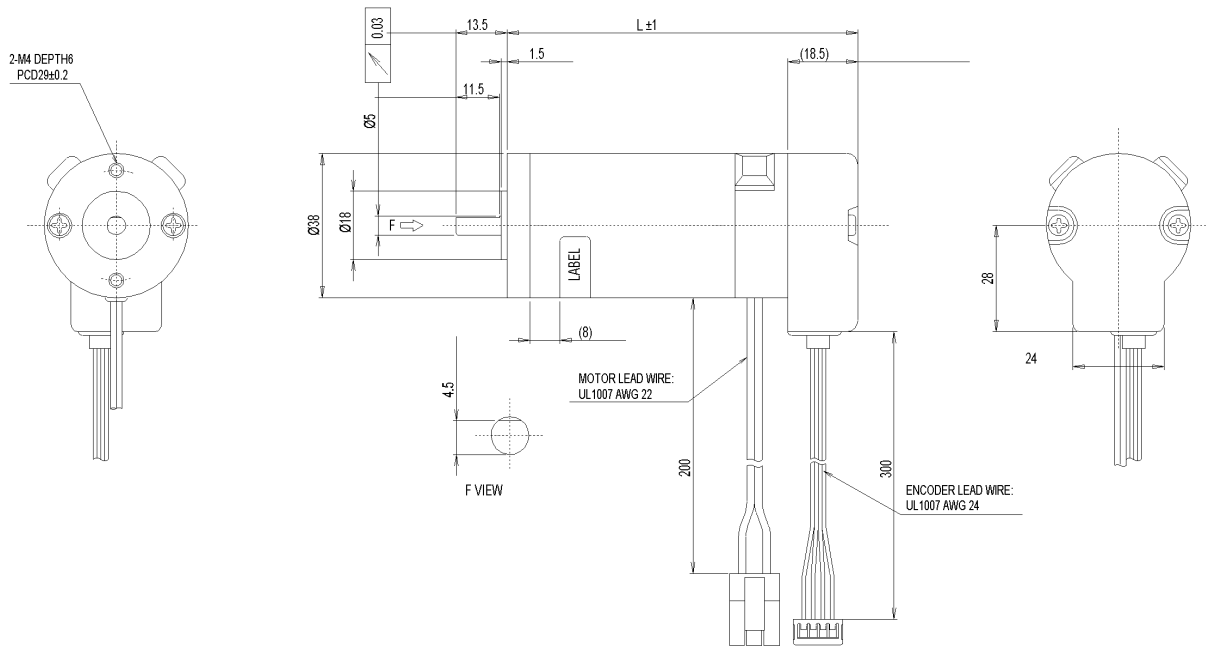

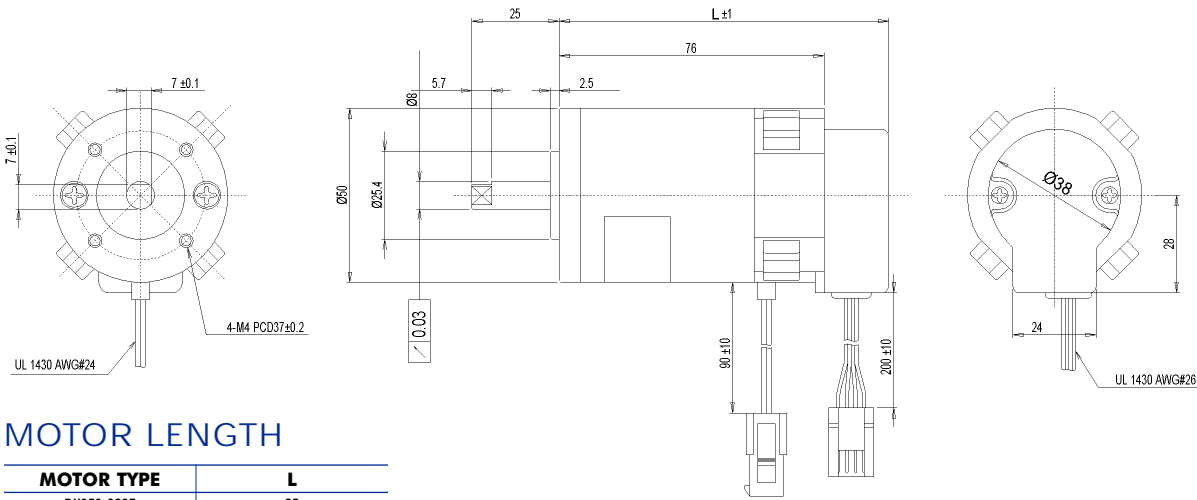

MOTOR LENGTH

MOTOR TYPE	L
DX050-020E	85
DX050-025E	95

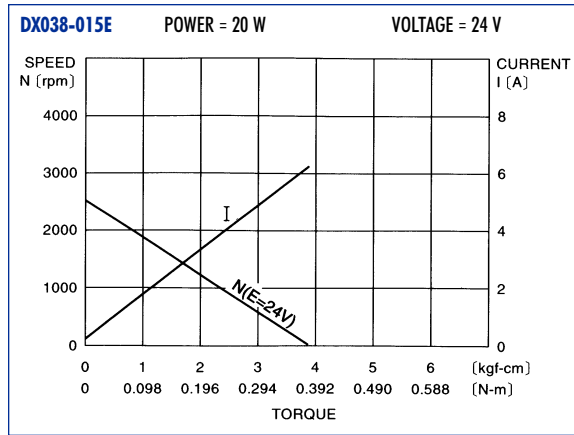
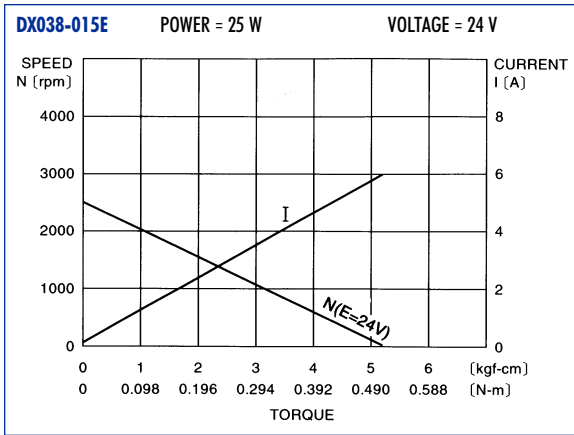

INERTIA B = A x constant

B \ A	oz-in ²	oz-in ²	lb-in ²	lb-in ²	Nms ²	g-cm ²	kg-m ²
oz-in ²	1	386.08	16	6.18 x 10 ²	5.46 x 10 ⁴	5.46 x 10 ³	5.35 x 10 ²
lb-in ²	1 / 16	24.13	1	386.08	3.41 x 10 ²	3.41 x 10 ⁴	3.35 x 10 ⁴
Nms ²	1.83 x 10 ⁵	7.06 x 10 ³	2.93 x 10 ⁴	0.113	1	1 x 10 ⁷	9.807
g-cm ²	182.9	7.06 x 10 ⁴	2.93 x 10 ²	1.13 x 10 ⁴	1 x 10 ⁷	1	9.807 x 10 ⁷

TORQUE B = A x constant

B \ A	g-cm	oz-in	ft-lbf	Ws (Nm)	Ncm	kg-cm
g-cm	1	72.0077	1.38 x 10 ⁴	1.02 x 10 ⁴	101.963	1 x 10 ²
oz-in	0.0139	1	192	141.6	1.416	13.9
ft-lbf	7.233 x 10 ⁵	1 / 192	1	0.737	7.37 x 10 ³	7.23 x 10 ²
Ws (Nm)	9.807 x 10 ⁵	7.06 x 10 ³	1.356	1	1 x 10 ²	9.8 x 10 ²
kg-cm	1 x 10 ³	7.06 x 10 ²	13.8	10.2	0.102	1

FORCE B = A x constant

B \ A	oz	lbf	N	kg	g
oz	1	16	3.6	35.27	35.27 x 10 ³
lbf	1 / 16	1	0.225	2.205	2.205 x 10 ³
N	0.278	4.448	1	9.807	9.807 x 10 ³
kg	0.028	0.454	0.102	1	1 x 10 ³
g	28.35	453.592	102.04	1 x 10 ³	1

SHINANO KENSHI CORP.

5737 MESMER AVENUE

CULVER CITY, CA 90230 USA

TEL: (310) 915-7300 • FAX: (310) 915-7304

www.shinano.com

e-mail: sales@shinano.com



HEADQUARTERS

SHINANO KENSHI CO., LTD.

1078 KAMIMARUKO, MARUKO-MACHI,
CHIISAGATA-GUN, NAGANO-KEN, 386-0498 JAPAN

TEL: (81268)41-1824

FAX: (81268)43-0010

www.skcyj.co.jp

TOKYO SALES OFFICE

1-4-21 KYODO, BLDG. 8F

YALSU CHUOKU, TOKYO, 103-0028 JAPAN

TEL: 813-5255-3561 • FAX: 813-5255-3563

SHINANO KENSHI (HONG KONG) CO., LTD.

SECTION D & E, 23RD FL., SOUTHEAST INDUSTRIAL BLDG.

611-619 CASTLE PEAK ROAD

TSUEN WAN, N.T. HONG KONG

TEL: 24110013 • FAX: 24136338

SHINANO KENSHI CHINA

DONGGUAN SHINANO MOTOR CO., LTD.

YAN TIAN DISTRICT, FUNG KONG, TUNG KOON

KWANG TUNG, CHINA

TEL: (86)-769-772046 • FAX: (86)-769-772134

