

# Special Torque Sensors for Cars (Wheel, Engine and Gear Box)

Flexplate Output flange, Climate Compressor

# Block Diagram

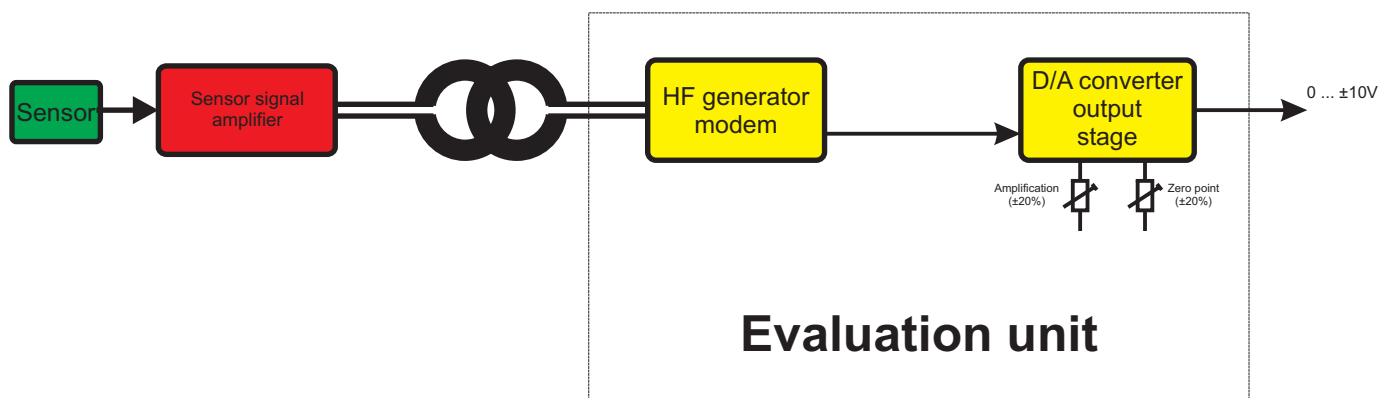

# Dynamic Torque Measurement at an Engine

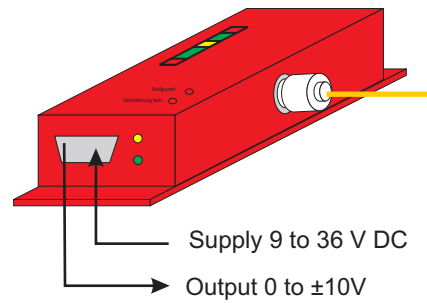
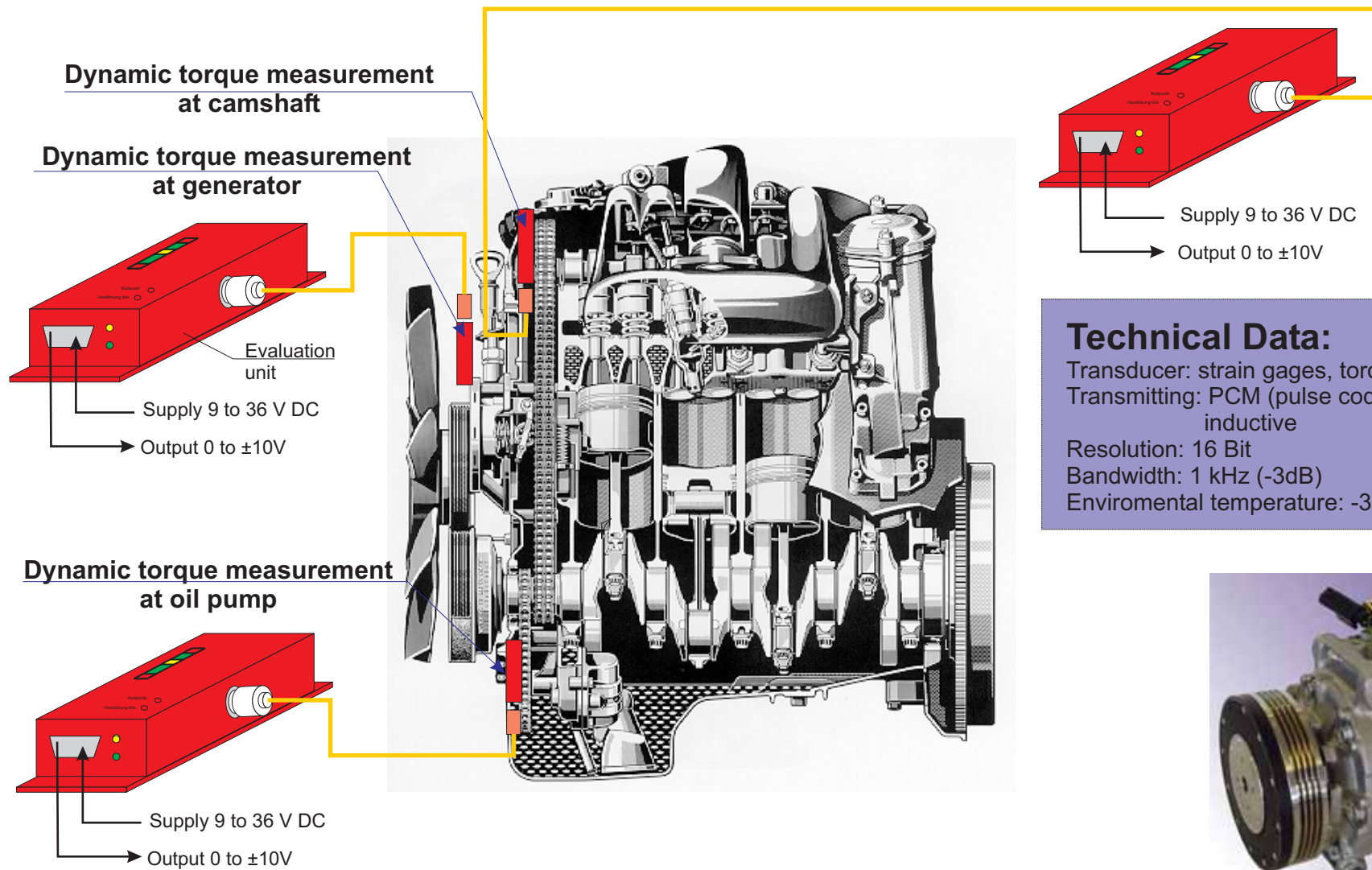

**Technical Data:**  
Transducer: strain gages, torque  
Transmitting: PCM (pulse code modulation), inductive  
Resolution: 16 Bit  
Bandwidth: 1 kHz (-3dB)  
Environmental temperature: -30 to 160°C



## Pulley for Climate Compressor

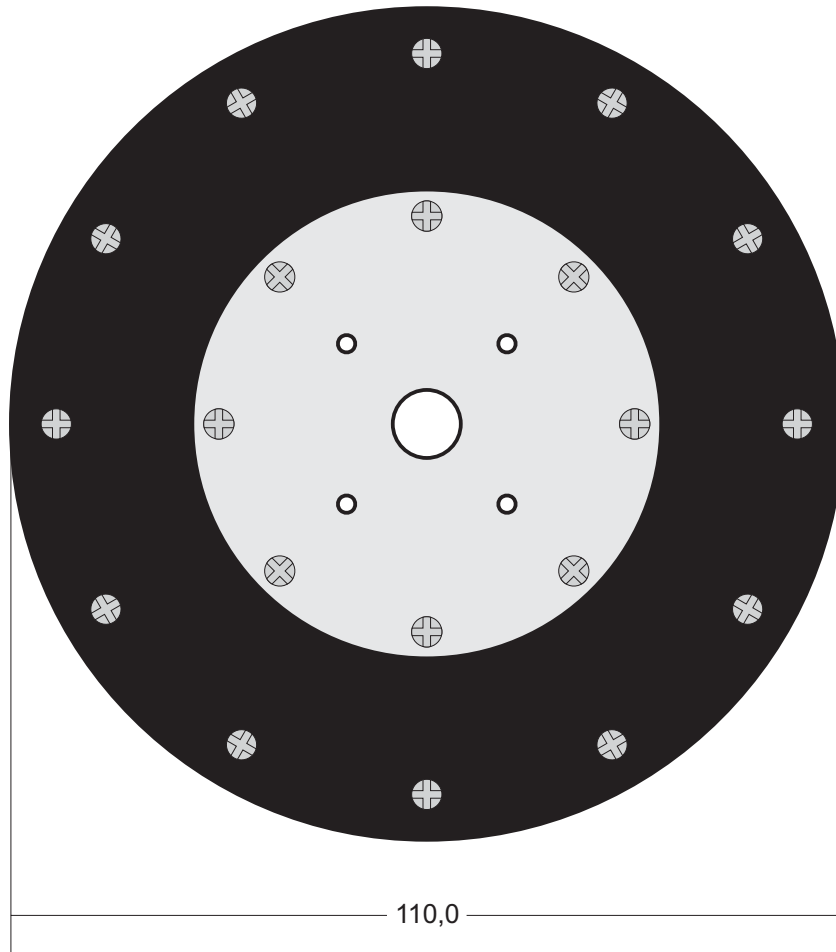
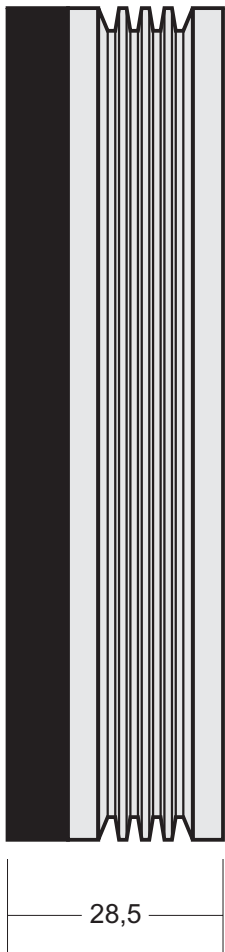

**Calsonic-Climate Compressor**



**Denso-Climate Compressor**



# Pulley for Climate Compressor

Compressor site

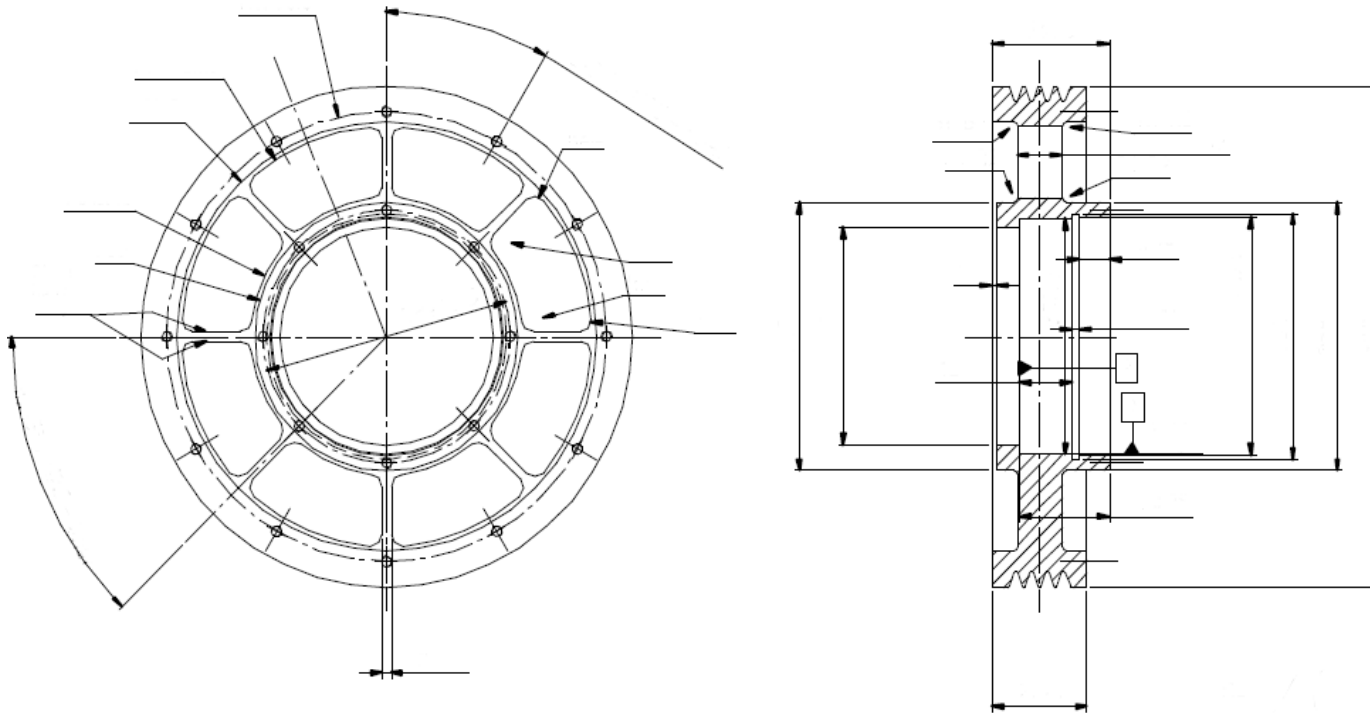

## Dynamic Torque Acquisition on Camshaft



### **Technical Data:**

Torque measuring disc,  
based on strain gage bridge measurement  
Measuring range: 100 Nm  
Accuracy: 0,1%  
Size: 20 mm  
Bandwidth per channel: 1 kHz (10 kHz)  
Digital technique  
Resolution 16 Bit  
Zero point drift: 0,002%/°C  
Enviromental temperature: -30 to 160°C

# Pulley for Generator

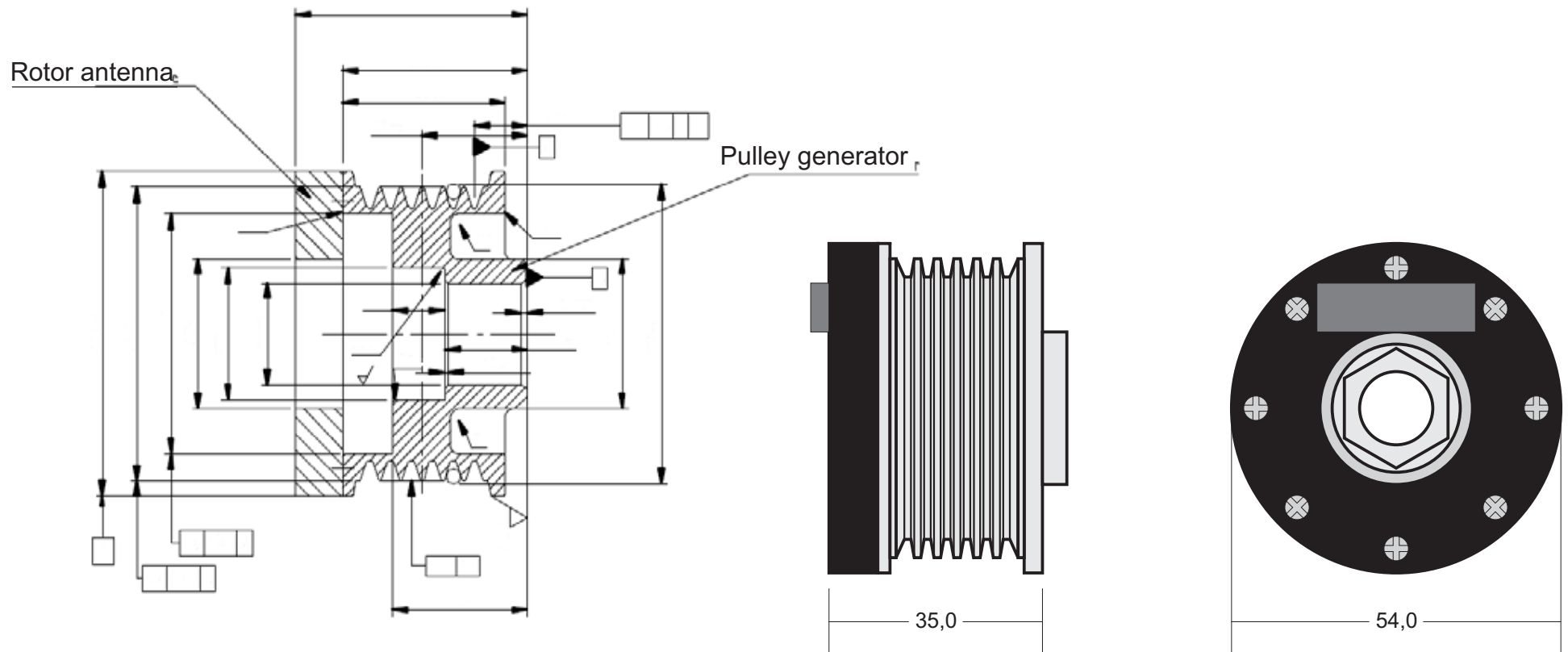



# Pulley for Flywheel

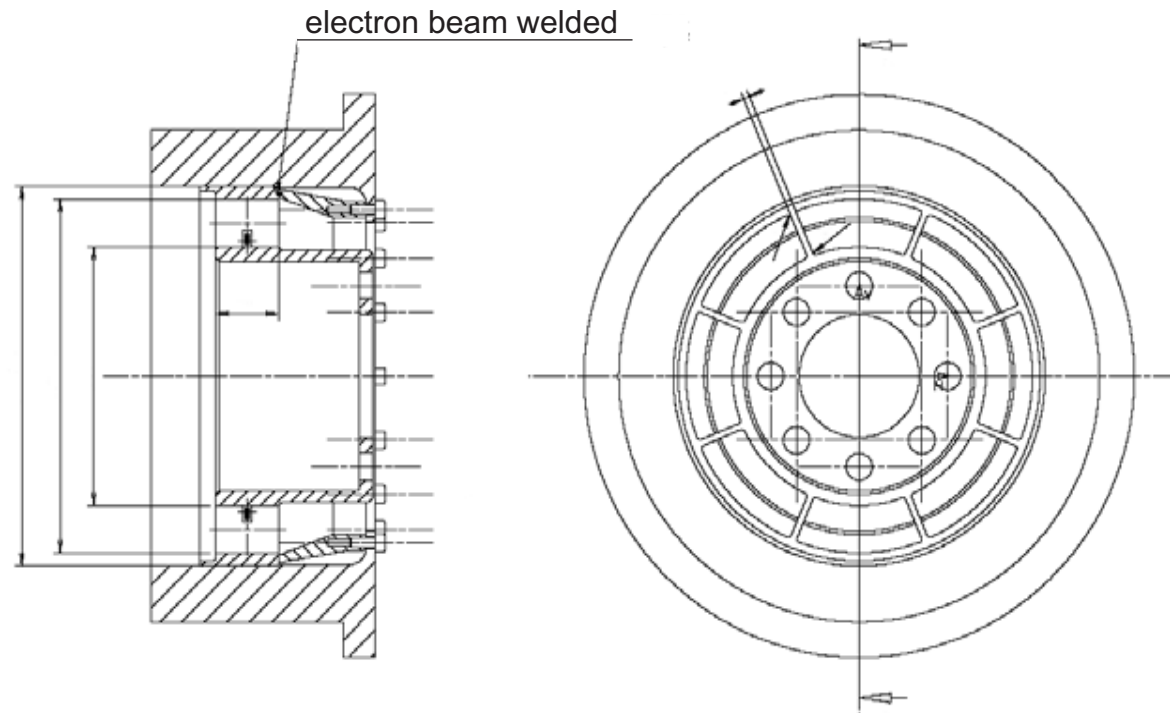

# Pulley for Steering Wheel Pump

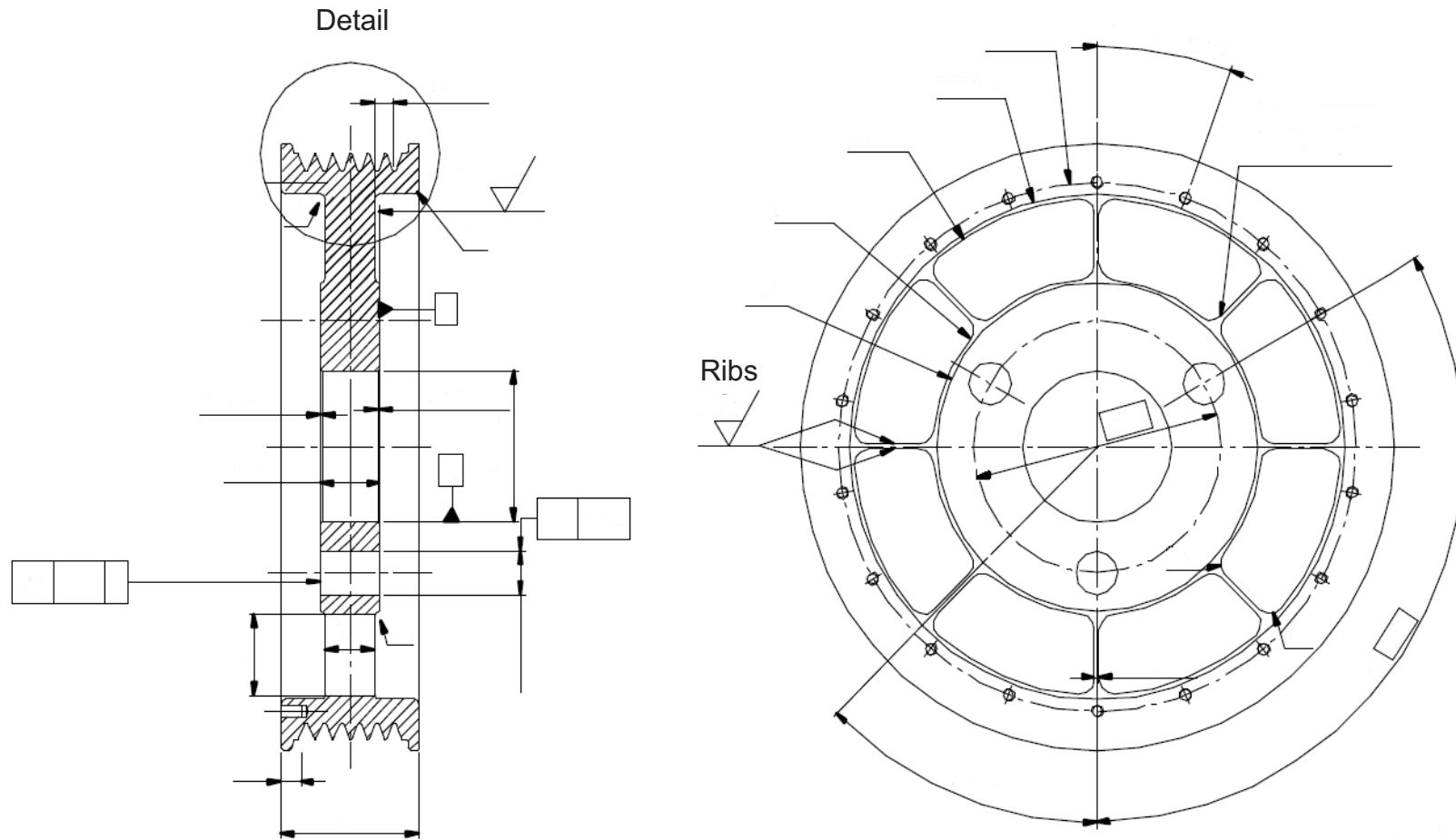

# Pulley for Steering Wheel Pump

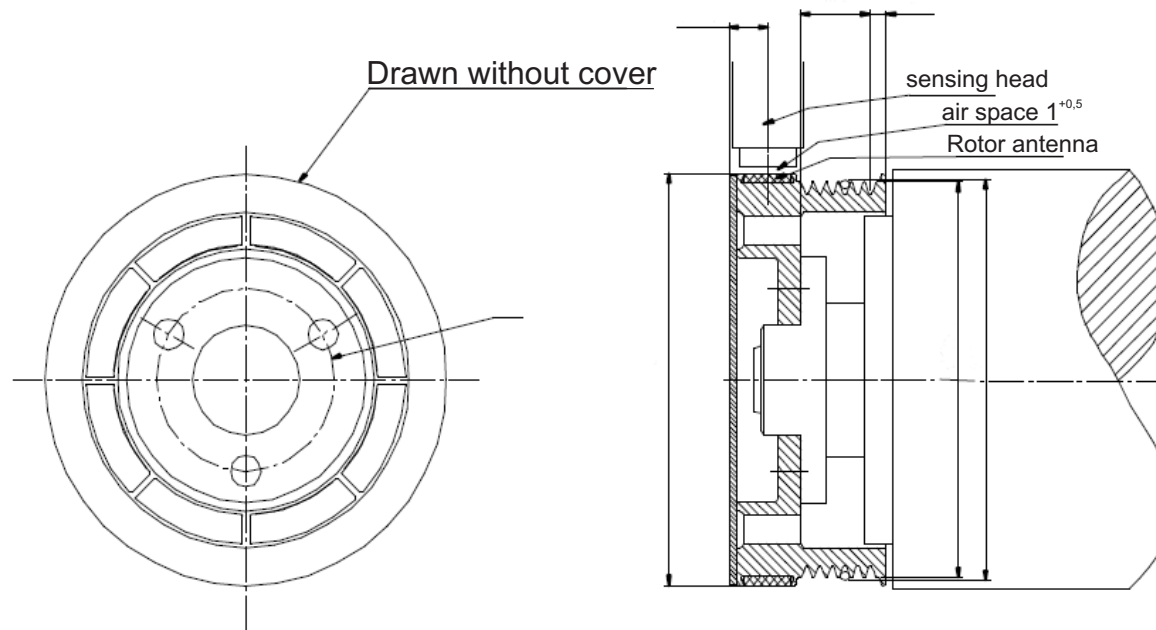

# Dynamic Troque Measurement at a Compressor

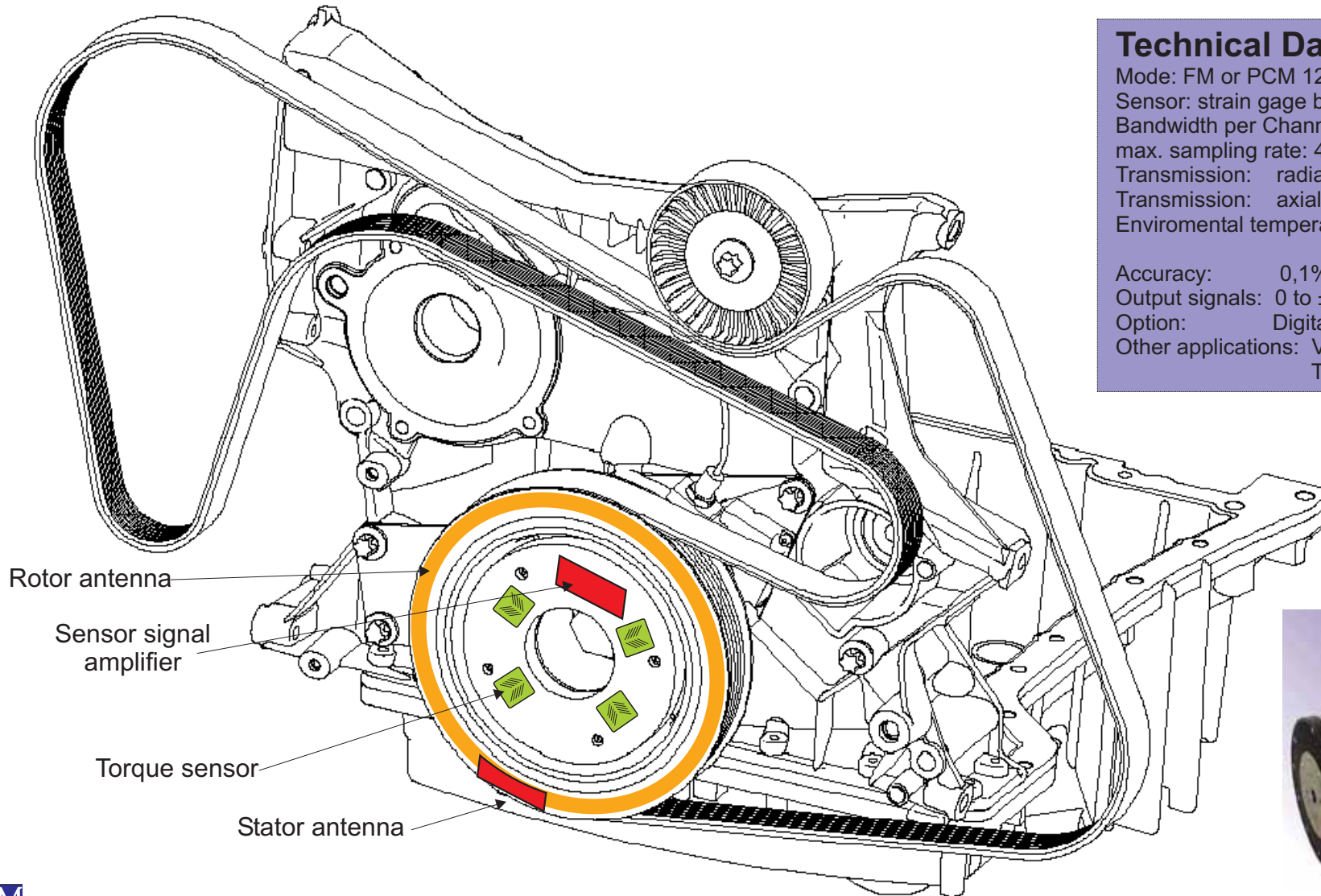

## Technical Data:

Mode: FM or PCM 12bit  
Sensor: strain gage bridge  
Bandwidth per Channel: up to 10 kHz(-3dB)  
max. sampling rate: 40000 Sample/sec./channel  
Transmission: radial, tolerance 0 to +15mm or  
Transmission: axial, tolerance 0 to +30mm  
Enviromental temperature: -10° to 85° Celsius  
-30° to +150° Celsius  
Accuracy: 0,1%  
Output signals: 0 to ±10V  
Option: Digital interface  
Other applications: Vibration analysis,  
Temperature measurement



# Coupling Climate Compressor

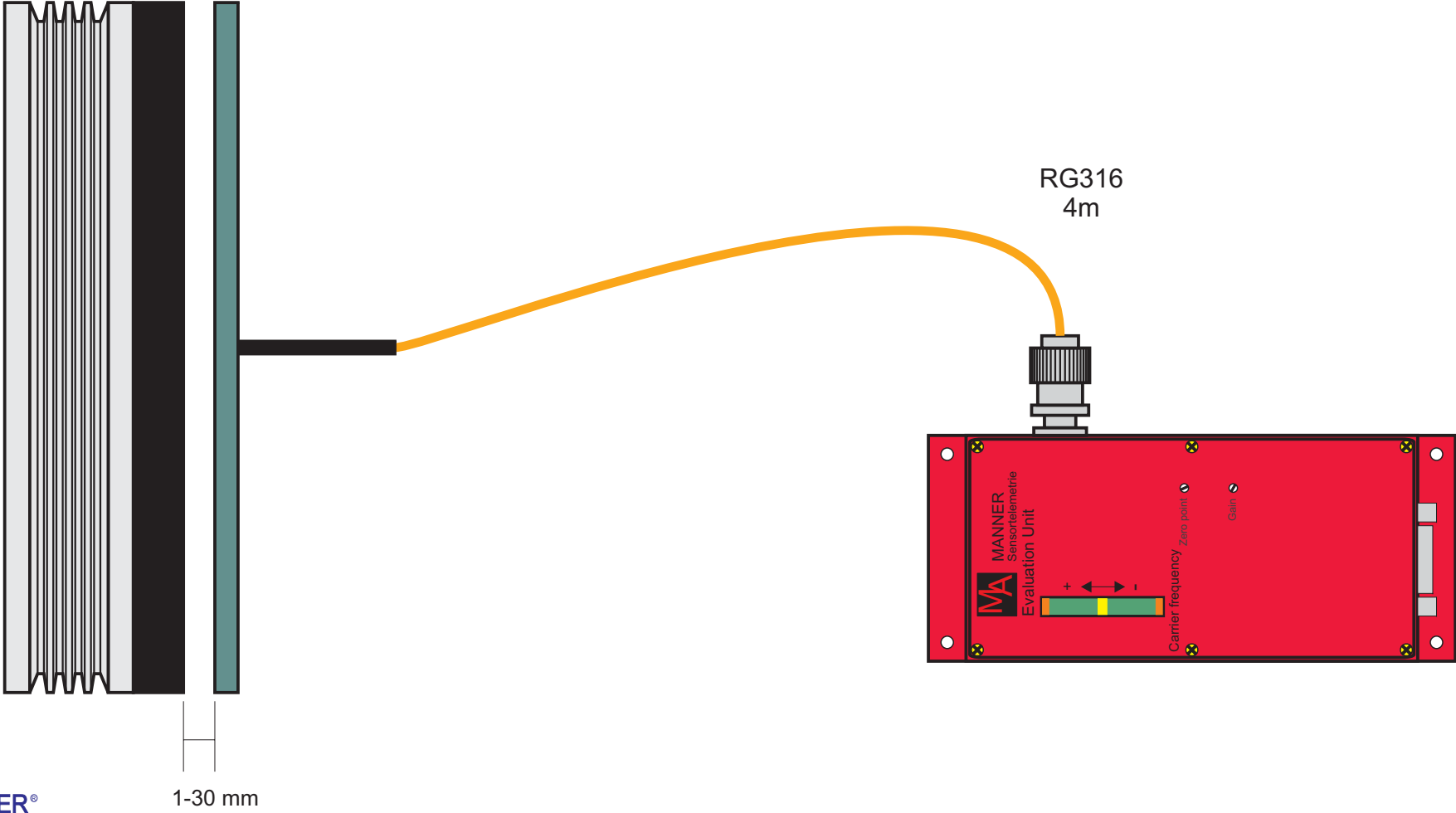

# Torque Meter for Propshaft

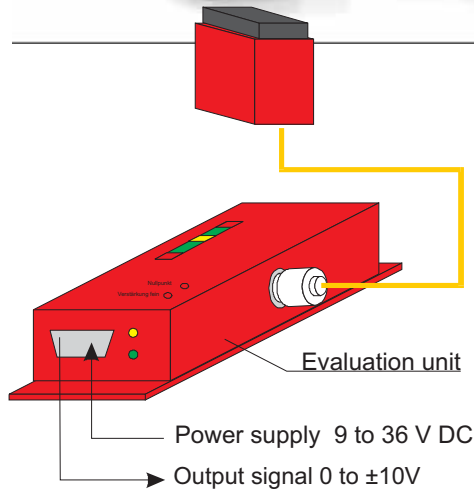

## Technical Data:

Bearing torque shaft,  
based on strain gage bridge measurement  
Measuring range: 2..6 kNm  
Accuracy: 0,1%  
Bandwidth per channel: 1 kHz (-3dB)  
Digital technique  
Resolution 16 bit  
Zero point drift: 0,002%/°C  
Environmental temperature: -30 to 160°C  
Integrated speed acquisition

# Torque Measuring Disk between Engine and Gear (Flexplate)

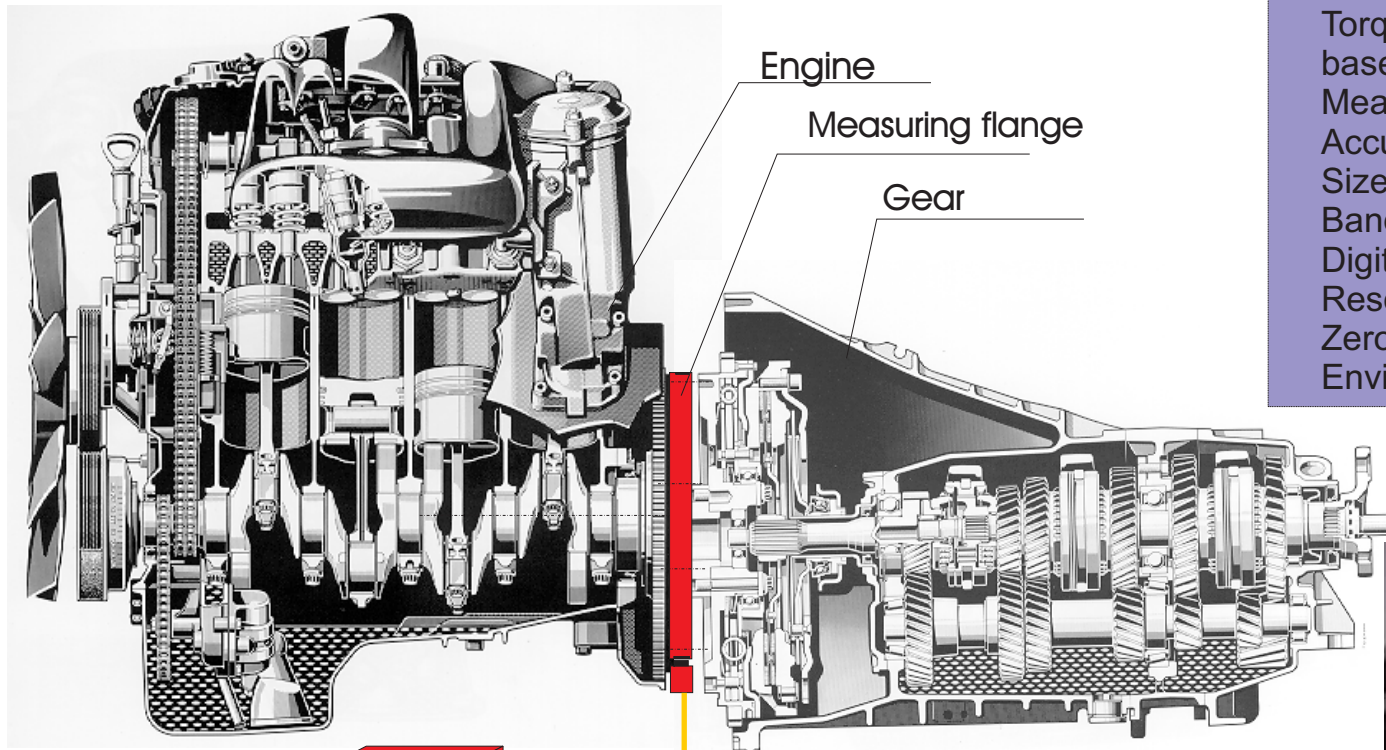

## Technical Data:

Torque measuring disc,  
based on strain gage bridge measurement  
Measuring range: 1kNm  
Accuracy: 0,1%  
Size: 20 mm  
Bandwidth per channel: 1 kHz (-3dB)  
Digital technique  
Resolution 16 bit  
Zero point drift: 0,002%/°C  
Enviromental temperature: -30 to 160°C

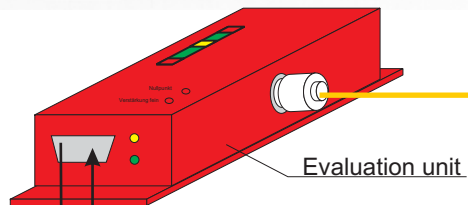

Evaluation unit

# Flexplate

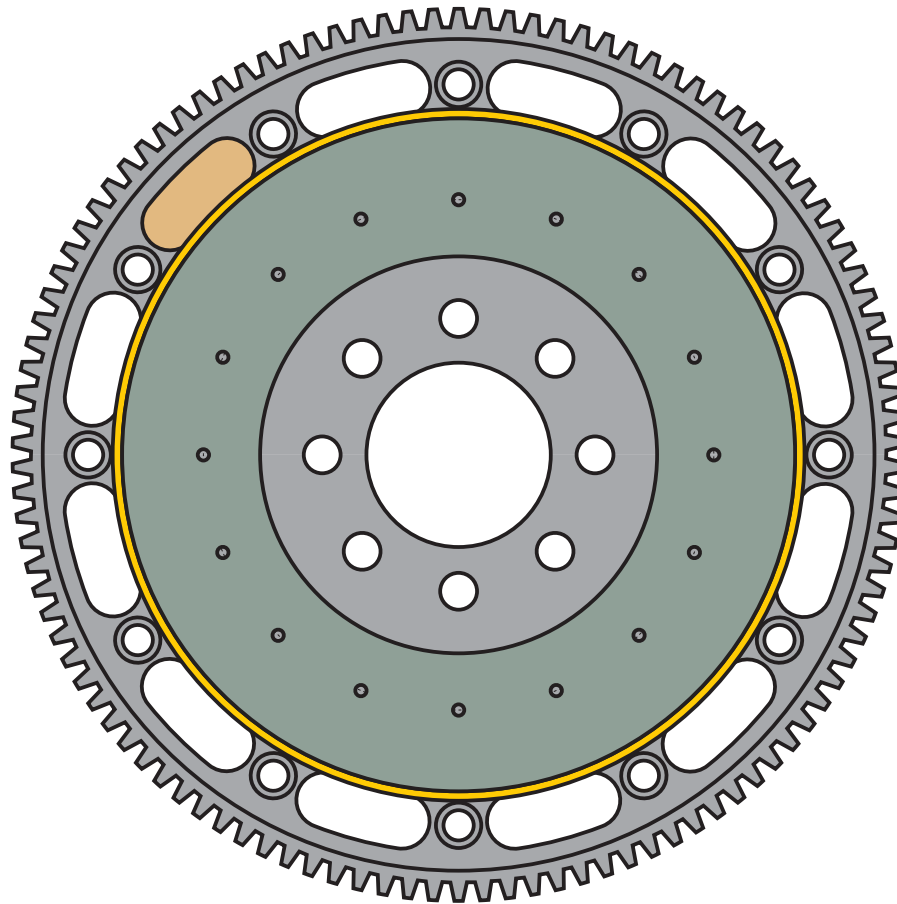
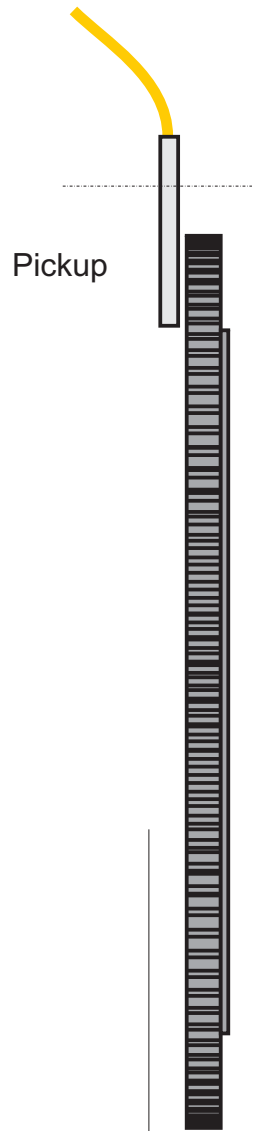

4 to 8 mm



# Torque Measuring at Gear (Input Shaft, Output Shaft)

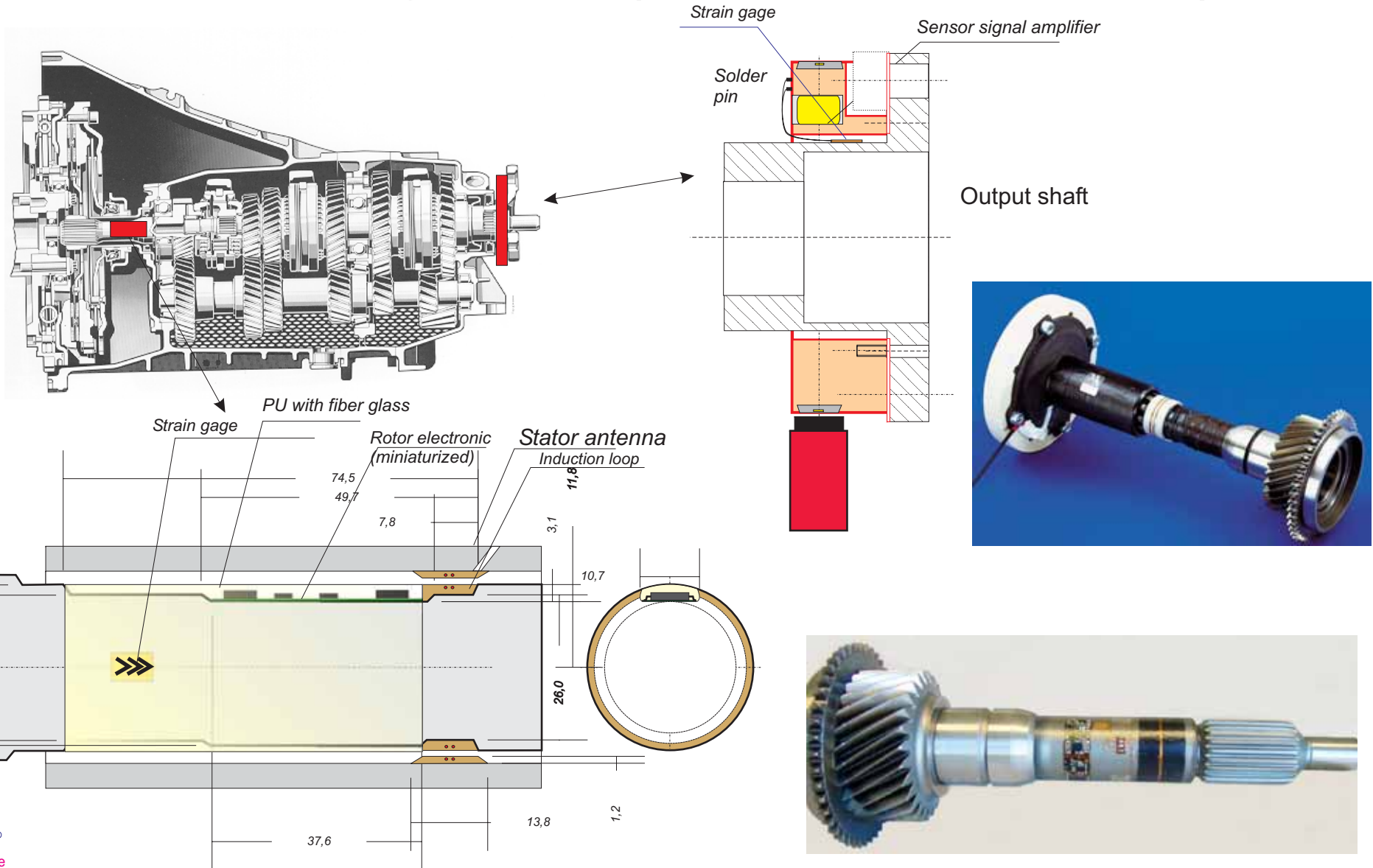

## Torque Measurement at Gear (Output Shaft)



# Wheel Torque Meter based on Radio Telemetry



Type: MFW\_<range>\_<precision>\_<bandwidth>\_<mod>\_F



Type: AW\_M\_<bandwidth>\_<supply>\_<output>\_<mod>\_F

## Features:

- Wheel torque meter for cars
  - Ranges available: 500 Nm to 4 kNm
  - Linearity and hysteresis: 0,1 %
  - Based on titanium with overload protection
  - High bandwidth 0 to 1 kHz(-3 dB)
  - High reliable digital transmitting 16 Bit resolution
  - Zerodrift / Gaindrift: 0,01 %/°C (0,003 %/°C optional)
  - Easy mounting
  - Transmitting: Radio f = 433/868 MHz, 16 different frequencies
  - Integrated transmitting antenna, waterproof
  - RF-Power: 10 mW; range: 20 m in open field
  - Integrated data protection by checksum (16 Bit CRC)
  - Low current consumption by low power C-MOS technique: 3,6 V supply with Accu-supply 3,6 V Lithium, max 35 hours (one cycle)
  - Max. radial acceleration: 1500 g
  - Temperature range: -25 to +85°C
  - Optional -40 to +120°C environmental temperature
  - Supply receiver: 9 to 36 V DC, 100 mA
  - Output voltage: 0 to ±10 V, 0(4) to 20 mA, USB, CAN-Bus
  - Type system: type: MFW\_<range>\_<precision>\_<bandwidth>\_<mod>\_<AW>\_F
- |        |      |        |       |      |
|--------|------|--------|-------|------|
| 500 Nm | 0,1% | 100 Hz | PCM16 | AW_M |
| to     |      | 1 kHz  |       |      |
| 4 kNm  |      |        |       |      |

## High precise Wheel Torque Sensor

### **Technical data:**

Torque measuring disc,  
Material: titanium  
based on strain gage bridge measurement  
Measuring range: 0,5/1/2/5 kNm  
Accuracy: 0,1%  
Size: 20 mm  
Bandwidth per channel: 1 kHz (-3dB)  
Digital technique  
Resolution 16 Bit  
Zero point drift: 0,002%/°C  
Temperature range: -30 to 125°C





# High Precise Wheel Torque flange with Radio Sensortelemetry



